

MULTIPROP System

Instructions for Assembly and Use – Standard configuration – Version 2.1



Overview

Main components	4
Accessories	5
Key	6

Introduction

Target groups	7
Additional technical documentation	7
Intended use	8
Instructions for Use	8
Cleaning and maintenance instructions	9

Safety instructions

Cross-system	10
System-specific	12
Storage and transportation	12

General information

Foreseeable misapplications	13
MULTIPROP variants	13
List of components	14
Tightening torques	14

Assembly and dismantling

A1	MULTIPROP Individual Prop	15
	Adjusting the extension length	15
A2	MULTIPROP System	16
	Connecting the props	16
	Frame MRK	17
	Compression Brace Head MP/SRU with Connector MP/SRU	19
	Tilting Base MP MKF	21
	Tilting Forkhead MP MKK	22
	Base MP 50	23
A3	Horizontal assembly	24
	Assembly with 4 legs	24
	Assembly with multiple number of legs	27
	Erecting the tower	28
A4	Vertical assembly	30
	First level	30
	Next level	31
	Additional levels	31
A5	Bracing MULTIPROP Towers	32
	Installing Brace Connector MP MR	32
	Bracing with push-pull props	34
	Supporting in units	35
A6	Accessories	36
	Strap MP U100-U140	36
	Connecting MULTIPROP MP to Alu Beam MP MB 24	36
	Coupler MP MB 24	37
A7	Dismantling	38
	Vertical dismantling	38
	Horizontal dismantling	39
A8	Storage and transportation	40

Application

B1	Structural scaffolding tube bracing	41
	Scaff. Tube Coupler MP MG	41
B2	Frame	42
	Use as scaffold platform beams	42
B3	Tables and towers	43
	Lowering	43
	Moving with the trolley with winch unit	44
	Moving along with pole	44
	Tables	45

Program overview

MULTIPROP System	46
------------------	----

Main components

1 MULTIPROP MP

- 1.1 Outer Tube
- 1.2 Inner Tube
- 1.3 Securing Hook
- 1.4 Adjusting nut
- 1.5 Compression Spring
- 1.6 Measuring scale
- 1.7 Rubbing plate
- 1.8 Base Plate
- 1.9 Head Plate

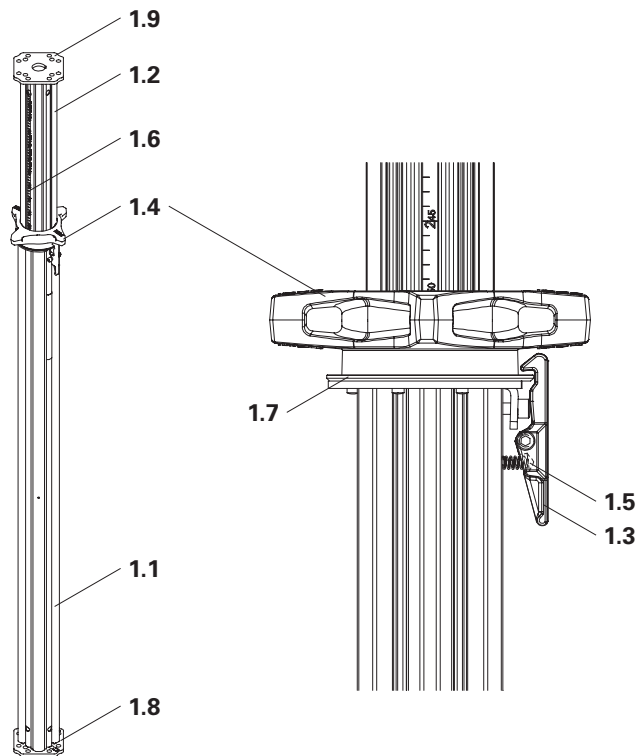

2 Frame MP MRK

- 2.1 Wedge Lock C
- 2.2 Wedge Lock D
- 2.3 Wedge
- 2.4 Sticker

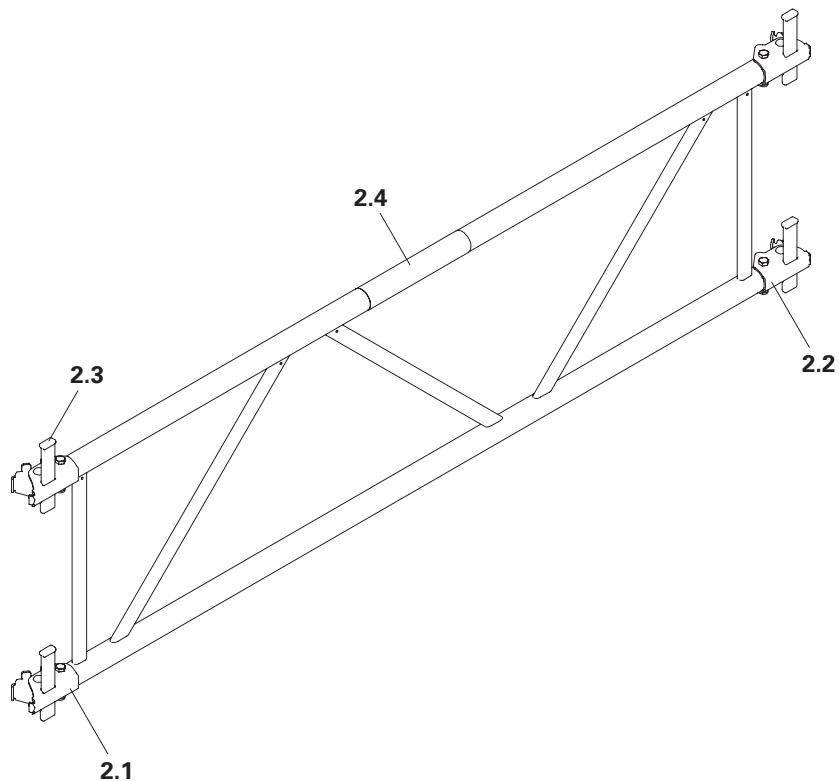

Accessories

3 Base MP 50

- 3.1 Head Plate
- 3.2 Clamping Claw
- 3.3 Centring Pin

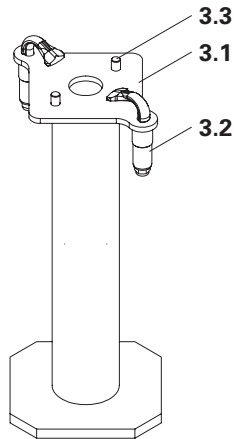

4 Tilting Base MP MKF

- 4.1 Head Plate
- 4.2 Clamping Claw
- 4.3 Centring Pin
- 4.4 Wing Bolt

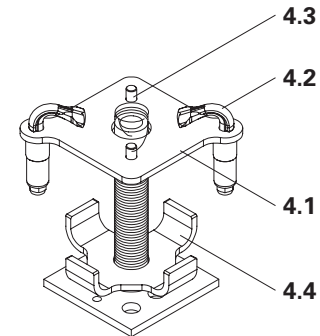

5 Tilting Forkhead MP MKK

- 5.1 Base Plate
- 5.2 Clamping Claw
- 5.3 Centring Pin
- 5.4 Wing Bolt

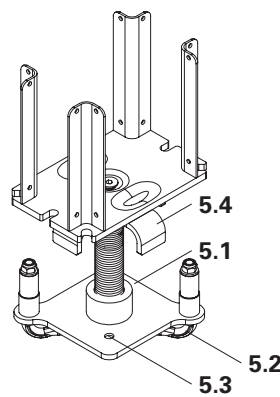

6 Strap MP U100-U140

- 6.1 Bracket
- 6.2 Main beam
- 6.4 Hex. Nut M16

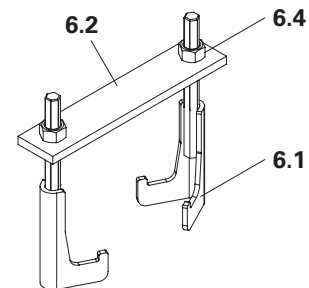

7 Connector-2 MP MV

- 7.1 Clamping Lever
- 7.2 Clamping Jaw
- 7.3 Centring Pin

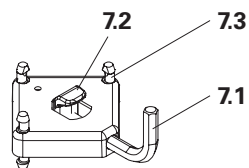

8 Screw with Nut MP

- 8.1 Retaining screw
- 8.2 Nut

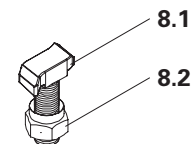

9 Compression Brace Head MP/SRU

19 Fitting Pin Ø21x120 mm

20 Cotter Pin 4/1 ga

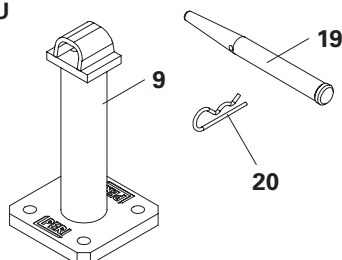

Key

Pictogram | Definition



Danger/Warning/Caution



Note



To be complied with



Load-bearing point



Visual inspection



Tip



Incorrect use



Safety helmet



Safety shoes



Safety gloves



Safety goggles



Personal protective equipment to prevent falling from a height (PPE)

Arrows



Arrow representing an action



Arrow representing a reaction of an action*



Arrow representing forces

* If not identical to the action arrow.

Safety instruction categories

The safety instructions alert site personnel to the risks involved and provide information on how to avoid these risks. Safety instructions can be found at the beginning of the section or before instructions for action and are highlighted as follows:



Danger

This sign indicates an extremely hazardous situation that could result in death or serious, irreversible injury if the safety instructions are not followed.



Warning

This sign indicates a hazardous situation that could result in death or serious irreversible injury if the safety instructions are not followed.



Caution

This sign indicates a hazardous situation that could result in minor or moderate injury if the safety instructions are not followed.



Note

This sign indicates situations in which failure to observe the information can result in material damage.

Format of the safety instructions



Signal word

Type and source of hazard!
Consequences of non-compliance.
⇒ Preventative measures.

Dimensions

Dimensions are usually given in cm. Other measurement units, e.g. m, are shown in the illustrations.

Conventions

- Instructions are numbered with: 1., 2., 3.
- The result of an instruction is shown by: →
- Position numbers are clearly provided for the individual components and are given in the drawing, e.g. **1**, in the text in brackets, for example **(1)**.
- Multiple position numbers, i.e. alternative components, are represented with a slash: e.g. **1/2**.

Notes on illustrations

The illustration on the front cover of these instructions is understood to be a system representation only. The assembly steps presented in these Instructions for Assembly and Use are shown in the form of examples with only one component size. They are valid for all component sizes contained in the standard configuration.

To facilitate understanding, detailed illustrations are sometimes incomplete. The safety equipment that might not be shown in these detailed illustrations must nevertheless be available.

Target groups

Contractors

These Instructions for Assembly and Use are designed for contractors who either

- assemble, modify and dismantle formwork systems, or
- use them, e.g. for concreting, or
- allow them to be used for other operations, e.g. carpentry or electrical work.

Competent person

(Construction site coordinator)

The Safety and Health Protection Coordinator*

- is appointed by the client,
- must identify potential hazards during the planning phase,
- determines measures that provide protection against risks,
- creates a safety and health protection plan,
- coordinates the protective measures for the contractor and site personnel so that they do not endanger each other,
- monitors compliance with the protective measures.

Competent persons qualified to carry out inspections

Due to the specialist knowledge gained from professional training, professional experience and recent professional activity, the competent person qualified to carry out inspections has a reliable understanding of safety-related issues and can carry out inspections correctly. Depending on the complexity of the inspection to be undertaken, e.g. scope of testing, type of testing or the use of certain measuring devices, a range of specialist knowledge is necessary.

Qualified personnel

Formwork systems may only be assembled, modified or dismantled by personnel who are suitably qualified to do so. Qualified personnel must have completed a course of training** in the work to be performed, covering the following points at least:

- Explanation of the plan for the assembly, modification or dismantling of the formwork in an understandable form and language.

- Description of the measures for assembling, modifying or dismantling the formwork.
- Naming of the preventive measures to be taken to avoid the risk of persons and objects falling.
- Naming of the safety precautions in the event of changing weather conditions which could adversely affect the safety of the formwork system as well as the persons concerned.
- Details regarding permissible loads.
- Description of all other risks and dangers associated with assembly, modification or dismantling operations.



- **In other countries, ensure that the relevant national guidelines and regulations in the respective current version are complied with!**
- **If no country-specific regulations are available, it is recommended to proceed according to German guidelines and regulations.**
- **A competent person must be present on site during formwork operations.**

* Valid in Germany: Regulations for Occupational Health and Safety on Construction Sites 30 (RAB 30).

** Instructions are given by the contractor themselves or a competent person selected by them.

Additional technical documentation

- Approvals:
 - Approval Z-8.22-802 MULTIPROP Shoring System
 - Approval Z-8.312-824 MULTIPROP Aluminium Prop
- Type tests:
 - MULTIPROP System
 - Compression Brace Head MP/SRU
- Instructions for Assembly and Use:
 - MULTIPROP MP 120, 250, 350, 480, 625 Slab Props
 - SKYDECK Panel Slab Formwork
 - GRIDFLEX Grid Element Slab Formwork
 - MULTIFLEX Girder Slab Formwork
- Instructions for use for the trolley with winch unit
- User information for pallets and stacking devices
- Technical data sheet for PERI Anchor Bolt SW24 Ø14/20x130 mm

Intended use

Product description

PERI products have been designed for exclusive use in the industrial and commercial sectors only by suitably trained personnel.

These Instructions for Assembly and Use describe the standard configuration for shoring in accordance with the provisions of DIN EN 12812. Shoring handles static loads and is not suitable for lifting or lowering components and constructions.

MULTIPROP MP can be used in combination with the Frame MP MRK as a table or tower to transfer vertical loads. The Outer Tubes of the MULTIPROP MP are powder-coated. The Frame MP MRK can be mounted on both the Outer and Inner Tube without changing the system dimensions. The integrated measuring scale and free-running collar allow accurate and fast height adjustment. The MULTIPROP MP has a fail-safe feature which prevents the Inner Tube from unintentionally slipping out. Markings on the Outer Tubes facilitate precise assembly of the Frames MP MRK. Only a hammer is required for the assembly work.

Features

The MULTIPROP System is used in shoring construction in a planned perpendicular position to transfer vertical loads.

Main components

MULTIPROP 120, L = 0.80 – 1.20 m
MULTIPROP 250, L = 1.45 – 2.50 m
MULTIPROP 350, L = 1.95 – 3.50 m
MULTIPROP 480, L = 2.60 – 4.80 m
MULTIPROP 625, L = 4.30 – 6.25 m

MULTIPROP Frame MRK, steel

Frame MP MRK 62.5
Frame MP MRK 75
Frame MP MRK 90
Frame MP MRK 120
Frame MP MRK 137.5
Frame MP MRK 150

MULTIPROP Frame MRK, aluminium

Frame MP MRK 201.5
Frame MP MRK 210
Frame MP MRK 225
Frame MP MRK 230
Frame MP MRK 237
Frame MP MRK 266
Frame MP MRK 296
Frame MP MRK 350

System dimensions

Assembly heights as individual props according to the permissible extension lengths 0.80 m – 6.25 m or 1.30 m – 6.75 m together with Base MP 50.

Assembly heights as a system with Frame MP MRK up to a maximum of 14.40 m, or 14.90 m with Base MP 50.

In the ground plan, square or rectangular depending on the Frame MP MRK used, from 0.625 m to 3.50 m.

Permissible load-bearing capacities = leg loads

Corresponding to Design Class B1 in accordance with DIN EN 12812.

The load-bearing capacity of the shoring towers in the MULTIPROP System is dependent on the position of the Frames MP MRK. The values are stated in the relevant current versions of the type test.

Instructions for Use

Use in a way not intended, deviating from the standard configuration or the intended use according to the Instructions for Assembly and Use, represents a misapplication with a potential safety risk, e.g. risk of falling.

Deviations from the standard configuration must be verified for the application by means of separate strength and stability calculations (Industrial Safety Regulation Appendix 1, No. 3.2.1 and explicitly reflected in the assembly instructions.)

Only PERI original components may be used. The use of other products and spare parts is not allowed.

Changes to PERI components are not permitted.

The system described in these Instructions for Assembly and Use may contain patent-protected components.

Cleaning and maintenance instructions

Clean the panels after each use to maintain the value and usability of the PERI products over the long term.

Some repair work may also be inevitable due to the tough working conditions. The following instructions should help to keep cleaning and maintenance costs as low as possible.

Never use steel brushes or hard metal scrapers to clean powder-coated or galvanised components.

Mechanical components, e.g. spindles, must be cleaned of dirt or concrete residue before and after use, and then greased with a suitable lubricant.

Provide suitable support for the components during cleaning so that no unintentional change in their position is possible.

Do not clean components suspended on crane lifting gear.

Any repairs to PERI products are to be carried out by PERI qualified personnel only.

Cross-system



Safety instructions apply to all service life phases of the system.

General information

The contractor must ensure that the Instructions for Assembly and Use supplied by PERI are available at all times and understood by the site personnel.

These Instructions for Assembly and Use can be used as the basis for creating a risk assessment. The risk assessment is compiled by the contractor. The Instructions for Assembly and Use are not a substitute for a risk assessment!

Observe and comply with the safety instructions and permissible loads.

For the application and inspection of PERI products, observe the current laws and regulations in force in the respective countries.

Materials and working areas are to be inspected before each use and assembly for:

- damage,
- stability and
- functional integrity.

Damaged components must be exchanged immediately on site and no longer used.

Safety components are to be removed only when they are no longer required.

When on slab formwork, scaffolds and working platforms:

- do not jump,
- do not run,
- do not drop anything from or onto it.

Components provided by the contractor must comply with the characteristics stipulated in these Instructions for Assembly and Use and all applicable laws and standards. Unless otherwise indicated, the following applies in particular:

- Timber components:
Strength class C24 for solid wood according to DIN EN 338:2016-07.
- Scaffolding tubes:
Galvanised steel tubes with minimum dimension $\varnothing 48.3 \times 3.2$ mm according to DIN EN 12811-1:2004-03 4.2.1.2.
- Scaffolding tube couplings:
according to DIN EN 74-1:2022-09 and DIN EN 74-2:2022-09.

Deviations from the standard configuration are only permitted after a further risk assessment has been carried out by the contractor.

Appropriate measures for working and operational safety, as well as stability, are defined on the basis of this risk assessment.

Corresponding proof of stability can be provided by PERI on request if the risk assessment and resulting measures to be implemented are made available.

Nails and wood screws must not protrude. Only allow other connecting components to protrude to the extent that is necessary. If necessary, mark protruding components or fit them with protective material.

Secure all bolts with cotter pins and all screws with nuts

Before and after extraordinary events that may have damaging effects on the safety of the system, the contractor must immediately

- produce another risk assessment, the results of which must be used to implement suitable measures to ensure the stability of the system,
- arrange for an extraordinary inspection to be carried out by a competent person qualified to do so. The aim of this inspection is to detect and repair damage in good time in order to ensure safe use of the system.

Exceptional events could be:

- accidents, fire, explosions, collisions,
- long periods of non-use,
- natural events, e.g. heavy rainfall, heavy snowfall, significant icing, storms or earthquakes.

Suitable measures could be:

- removing nets/tarpaulin,
- clearing snow and ice,
- reducing live loads,
- securing loose materials.

Assembly, modification and dismantling work

PERI systems may only be assembled, modified or dismantled under the supervision of a person qualified to do so and by suitably qualified employees. The qualified personnel must have received appropriate training for the work to be carried out with regard to specific risks and dangers.

On the basis of the risk assessment and Instructions for Assembly and Use, the contractor must create installation instructions in order to guarantee safe assembly, modification and dismantling of the climbing unit.



The contractor must ensure that the personal protective equipment required for the assembly, modification or dismantling of the scaffolding system, e.g.

- Safety helmet,
- Safety shoes,
- Safety gloves,
- Safety goggles,

is available and used as intended.

For work at a higher level, use an approved ladder or platform system, or an assembly scaffold.



If personal protective equipment against falling from a height (PPE) is required or specified in local regulations, the contractor must determine appropriate attachment points on the basis of the risk assessment. The PPE to be used to prevent falling is determined by the contractor.

The contractor must

- provide safe working areas for site personnel, which are to be reached through the provision of safe access ways. cordon off and clearly mark danger zones.
- guarantee stability during all stages of construction, in particular during assembly, modification and dismantling operations.
- ensure and demonstrate that all loads that occur are safely transferred.

Use

Every contractor who uses or allows the PERI systems to be used, is responsible for ensuring that the equipment is in good condition.

If the system is used successively or at the same time by several contractors, the health and safety coordinator must point out any possible mutual hazards and all work must then be coordinated.

When systems are used in publicly accessible areas,

- measures to prevent unauthorised use, e.g. enclosure of access areas, must be taken.
- measures to prevent injuries caused by bumping against protruding components, e.g. assembly of protective components, must be taken.

Always keep the contact surfaces of the system free of dirt, objects, snow and ice.

Close off the system in extreme weather conditions.

System-specific

Strike components only when the concrete has sufficiently hardened and the person in charge has given the go-ahead for deshuttering to take place.

Anchoring is to take place only if the anchorage has sufficient concrete strength.

The load-distributing support used, e.g. planking, must match the respective substrate. If multiple layers are required, planks are to be arranged crosswise.

Tighten couplings with screw closures using 50 Nm. This corresponds to a force of 20 kg using a lever arm length of 25 cm.

Secure the wedges with a jarring blow using a 500 g hammer.

Storage and transportation

Store and transport components in such a way that no unintentional change in their position is possible. Detach load-lifting accessories and lifting gear from the lowered components only if they are in a stable position and no unintentional change is possible.

Do not drop the components.

Use PERI lifting accessories and lifting gear and only those load-bearing points provided on the component.

During the moving procedure

- Ensure that components are picked up and set down in such a way that unintentional falling over, falling apart, sliding, falling down or rolling is avoided.
- no one is allowed to remain under the suspended load.

Always guide pre-assembled scaffolding bays, scaffolding units or scaffolding sections with ropes when moving them by crane.

The access areas on the construction site must be free of obstacles and tripping hazards, and must also be slip-resistant.

For transportation, the substrate must have sufficient load-bearing capacity.

Use original PERI storage and transport systems, e.g. crate pallets, pallets or stacking devices.

Foreseeable misapplications



Applications of this kind or a similar kind are prohibited!

Do not use slab props with broken or damaged nuts!

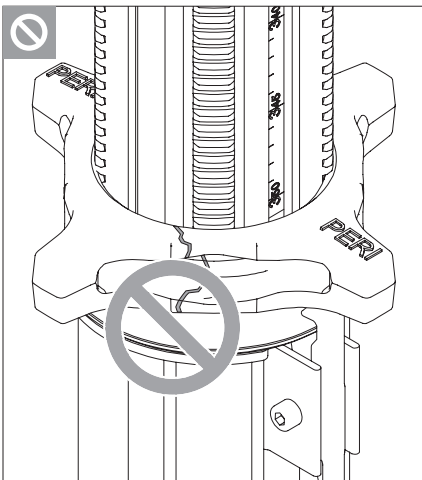

Fig. 01a

Do not use slab props with bent end plates or cracked seams on the end plates!

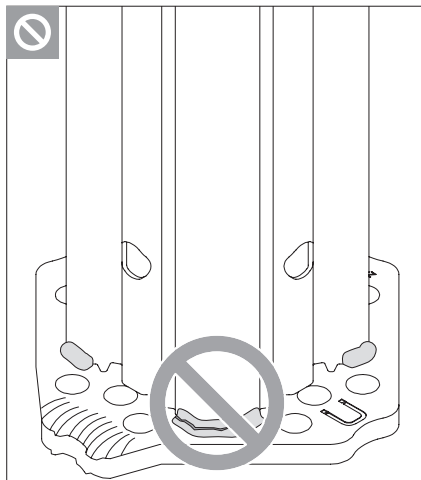

Fig. 01b

Do not use slab props with bent rubbing plates!

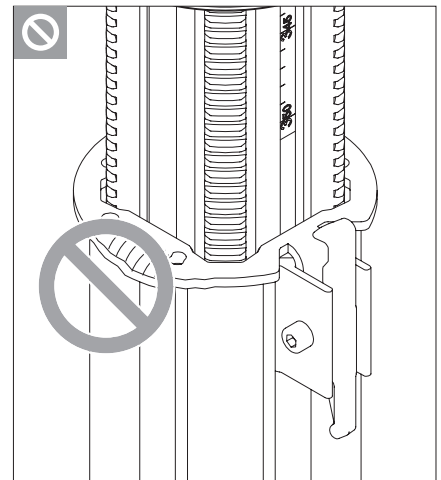
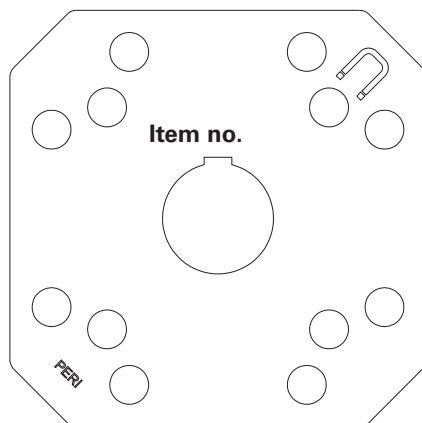

Fig. 01c

MULTIPROP variants

Shape of the end plates according to DIN EN 16031



Shape of the end plates according to approval

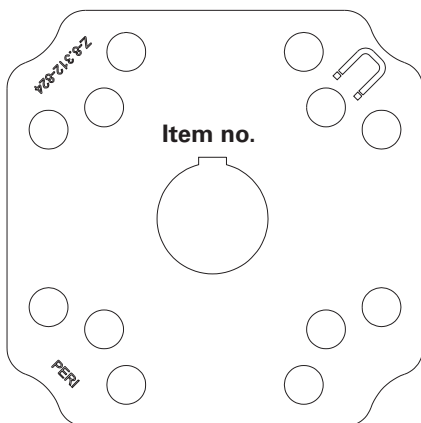

Props from recent production are manufactured in accordance with DIN EN 16031 and therefore no longer require approval. Both variants can be used without restrictions in accordance with the Instructions for Assembly and Use.

List of components

Pos. no.	Component name	Article no.	Pos. no.	Component name	Article no.
1	MULTIPROP MP	–	14	Swivel Coupler AF Ø48/48 mm	017010
2	Frame MP MRK	–	15	Scaff. Tube Coupler MP MG	–
3	Base MP 50	027310	16	Deck MP	–
4	Tilting Base MP MKF	027296	17	Connector MP/SRU	107160
5	Tilting Forkhead MP MKK	027297	18	Strap MP MB 24	107820
6	Strap MP U100-U140	027302	19	Fitting Pin Ø21x120 mm	104031
7	Connector-2 MP MV	027301	20	Cotter Pin 4/1 ga	018060
8	Screw with Nut MP	111142	21	Coupler MP MB 24	107348
9	Compression Brace Head MP/SRU	107161	22	Alu Beam MP MB 24	–
10	Scaff. Tube Ø48.3x3.2 mm	026415	23	Pin Ø20x140 mm ga	105400
11	4-sling lifting gear	-	24	Reinforcement bar	–
12	Universal Tripod Ø57-120 mm	028000	25	Pole	–
13	Brace Connector MP MR	129565			

Tightening torques

Unless otherwise indicated, PERI recommends the following guide values for screw connections as “hand-tightened” tightening torques $M_{A,hand-tightened}$. These guide values are based on DIN EN 15048-1:2016-09 with minimum Safety Factor 3 against breakage.

Quality class	Quality 4.6		Quality 8.8 and 10.9
	Lightly oiled	MoS2	Undefined
Screw M8	8 Nm	6.6 Nm	8 Nm
Screw M10	16 Nm	13.0 Nm	16 Nm
Screw M12	30 Nm	23.0 Nm	30 Nm
Screw M16	65 Nm	54.0 Nm	65 Nm
Screw M20	100 Nm		100 Nm
Screw M24	150 Nm		150 Nm
Screw M30	260 Nm		260 Nm
Screw M36	350 Nm		350 Nm

Tightening torques have been determined for the following components:

Scaffolding tube coupling	50 Nm
Clamping plate for the slab tie gauge	120 Nm

Adjusting the extension length



- Lift the MULTIPROP MP (1) in such a way that the adjusting nut runs downwards.
- The MULTIPROP MP (1) can be continuously readjusted by means of the adjusting nut if partially loaded up to 15 kN.
- Use a Wing Nut Spanner HD in order to allow the prop to spindle unencumbered with loads > 60 kN.
- From time to time, grease the contact surface between the adjusting nut and the rubbing plate with a suitable lubricating agent to ensure easier handling.

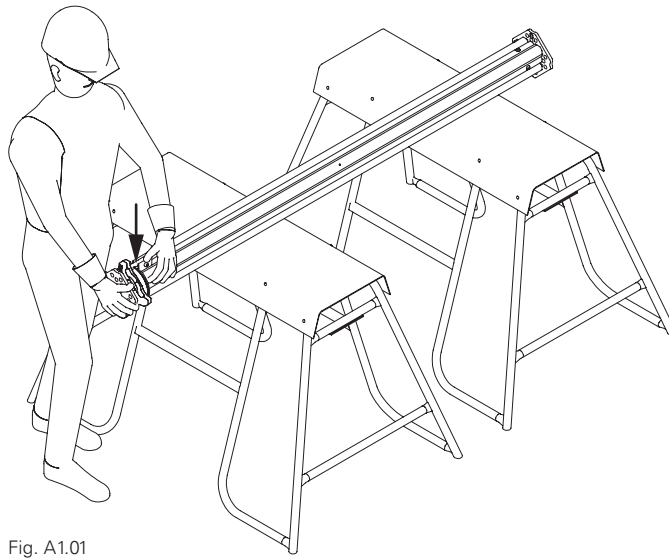

Fig. A1.01



Pallets serve as a secure prop support.

Preparation

Place the MULTIPROP MP (1) with retracted Inner Tube on an appropriately-positioned trestle/pallet. (Fig. A1.01)

Adjusting the extension length

1. Press Securing Hook (1.3).
→ The adjusting nut (1.4) is disconnected. (Fig. A1.01a)
2. Extend Inner Tube (1.2) to the required prop length.
(Fig. A1.01a + Fig. A1.01b)
3. Use the adjusting nut on the integrated measuring tape (1.6) to set the exact prop length. The adjustment travel per revolution is 36 mm.
4. Push in the Inner Tube until the adjusting nut is lying against the rubbing plate (1.7). (Fig. A1.02)
5. Lock the Securing Hook in place.
→ The prop has now been adjusted.

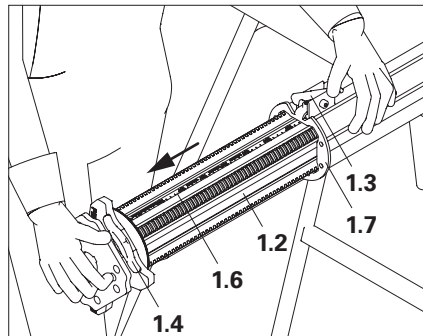

Fig. A1.01a

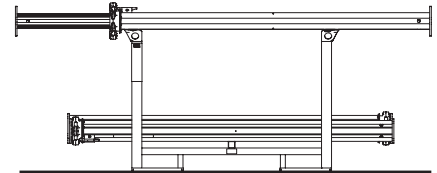

Fig. A1.01b



Is the Securing Hook locked?



If the Tilting Base MP MKF and Tilting Forkhead MP MKK need to be installed, they can be pre-installed now.

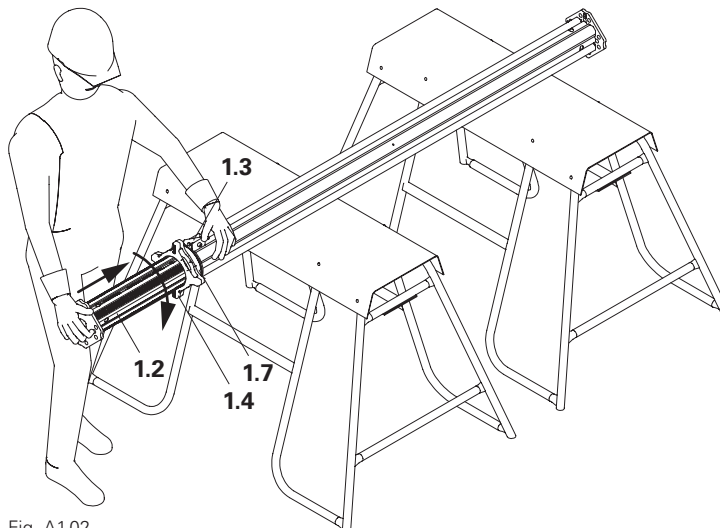

Fig. A1.02

Connecting the props



- Only use stacked MULTIPROPS MP (1) as a tower.
- Brace with Frame MP MRK (2).
- Check connections to ensure fittings are tight.

Connector-2 MP MV

The Connector-2 MP MV (7) connects two MULTIPROPS MP (1).

Assembly

1. Insert Centring Pins (7.3) into the drilled holes of the Base (1.8) or Head Plate (1.9).
 2. Place the second MULTIPROP MP (1) on the Centring Pins of the Connector-2 MP MV (7).
 3. Turn Clamping Lever (7.1) to the right and firmly tighten.
 - Engage Clamping Jaws (7.2) in the central hole of the prop.
- The MULTIPROPS MP (1) are connected.

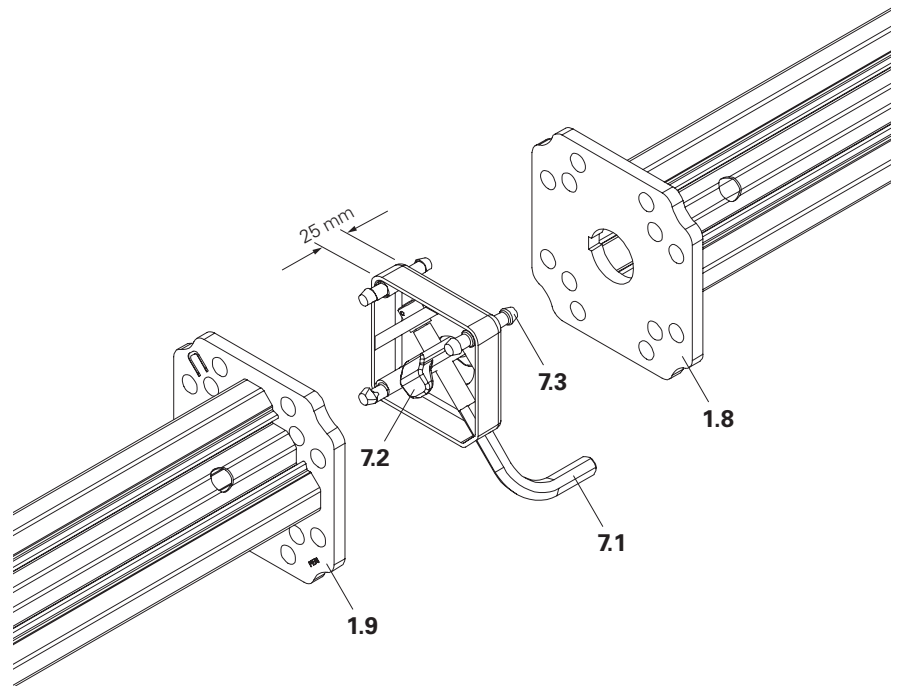

Fig. A2.01

The tower height can be adjusted by means of the integrated measuring scale. Add 2.5 cm for each Connector-2 MP MV (7).

Screw with Nut MP

As an alternative to Connector-2 MP MV (7), the end plates of the two props can be connected using two diagonally arranged Screws with Nut MP (8). (Fig. A2.02 + Fig. A2.02a)

Assembly

1. From the bottom, insert the bolt (8.1) through the drilled hole.
2. Open nut (8.2) with the collar facing the Head Plate (1.9) and tighten, AF 19.

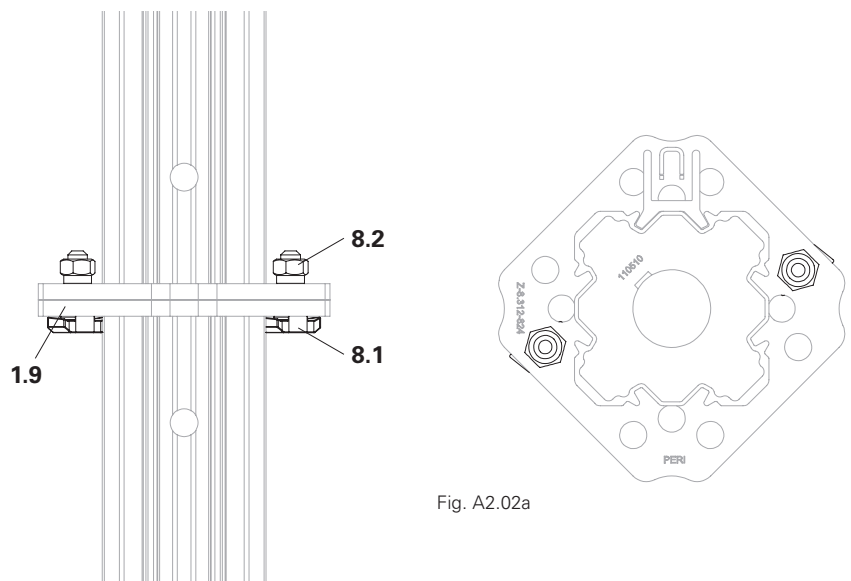

Fig. A2.02a

Fig. A2.02

Frame MRK



- Place or set the Frames MP MRK down in a secure position (2) so that they cannot tip over.
- Do not damage the wedge connection.

Assembly

Always mount the Frames MP MRK (2) on the MULTIPROP MP (1) in such a way that the wedge can be hit into position with the hammer from top to bottom. (Fig. A2.03)

If required, use the tripod as an assembly aid during assembly.

- Open wedge connection C (silver) (2.1) or D (yellow or black) (2.2). The wedge (2.3) is at the top. (Fig. A2.04)
 - Engage the wedge connection in the profile grooves of the MULTIPROP MP (1). (Fig. A2.05)
 - Keep the wedge connection closed.
 - Firmly strike the wedge with the hammer.
 - Close the other wedge connections in the same way.
- The Frame MP MRK (2) is attached to the MULTIPROP MP (1). (Fig. A2.05)



Do not mount the Frame MP MRK (2) in the transition area of the Inner Tube / Outer Tube, as this will block the extension and retraction operation of the MULTIPROP MP (1). (Fig. A2.03a)



If the wedge (2.3) slips through, there is no clamping effect!

- In this case, release the wedge (2.3) and reconnect.
- For a tight connection to the Outer or Inner Tube with jaw opening variant "a", two wedge courses are integrated in the wedge (2.3) itself (Fig. A2.05 jaw opening "a")
- The profile of the MULTIPROP MP (1) must be clean in the clamping area, e.g. free of concrete residue. (Fig. A2.06)

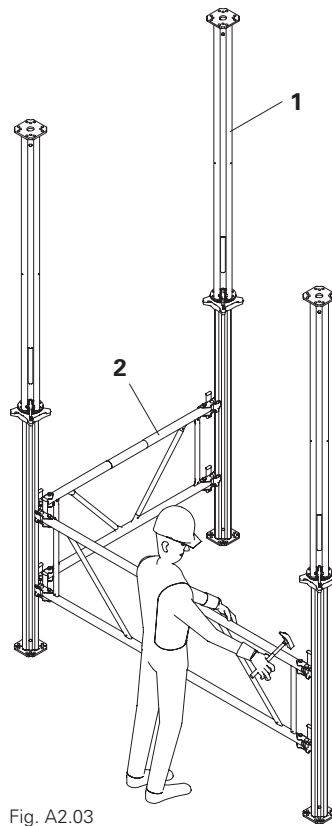

Fig. A2.03

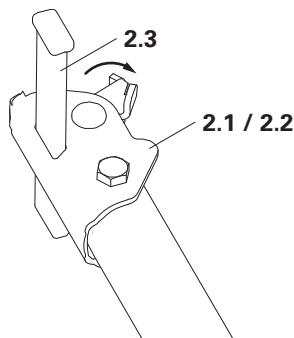

Fig. A2.04

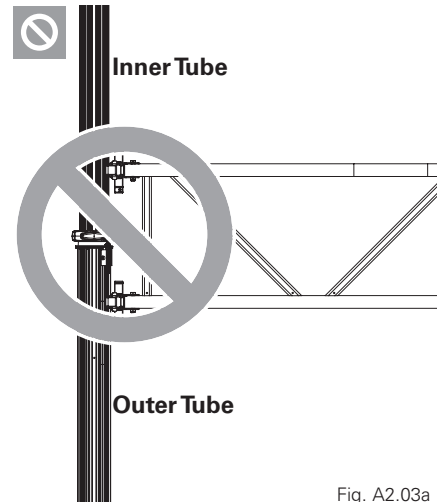
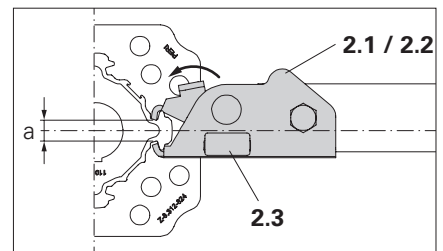

Fig. A2.03a

Inner Tube



Outer Tube

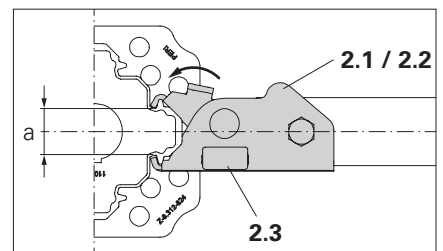

Fig. A2.05

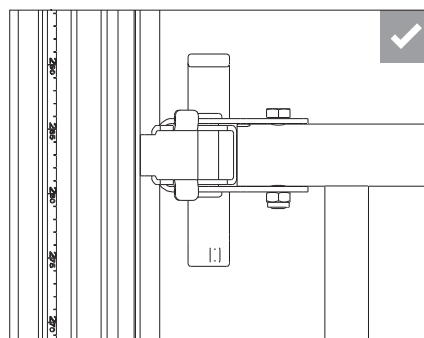
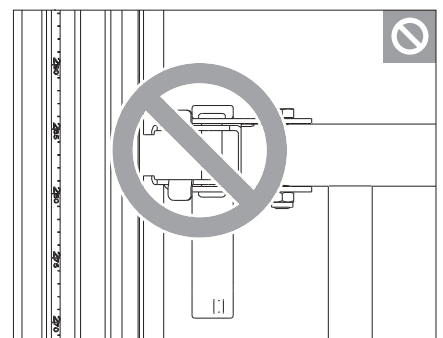

Fig. A2.06



Arrangement of the Frames MP MRK

Universally valid

The arrangement of the Frames MP MRK (2) is shown in the corresponding diagram contained in the type test.

Marking on the Outer Tube

Arrange the Frames MP MRK at the circular-shaped recesses (1.10) of the Outer Tube (1.1). This results in a distance of 40 cm to the Base Plate. (Fig. A2.07a + Fig. A2.07b)

Upper Outer Tube

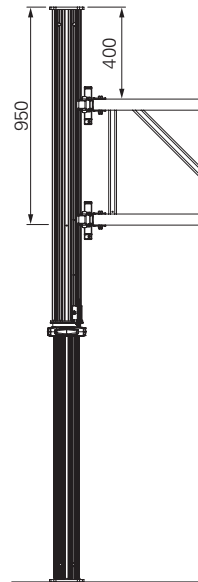

Fig. A2.07a

Lower Outer Tube

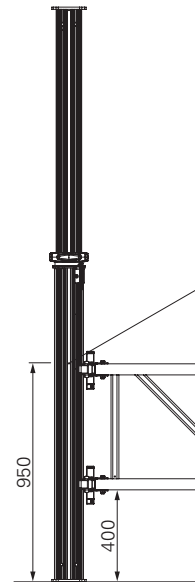

Fig. A2.07b

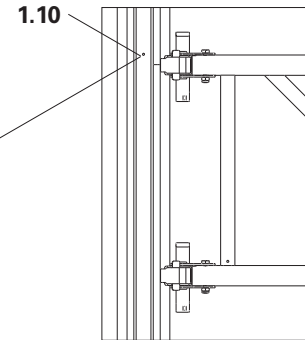

Fig. A2.07c

Outer Tube + Inner Tube



Only wedge connections of the same colour are permissible at a connection point.

(Fig. A2.08)

When inserted, the wedges (2.3) of the wedge connections must always be pointed downwards so that any self-actuating loosening is not possible.

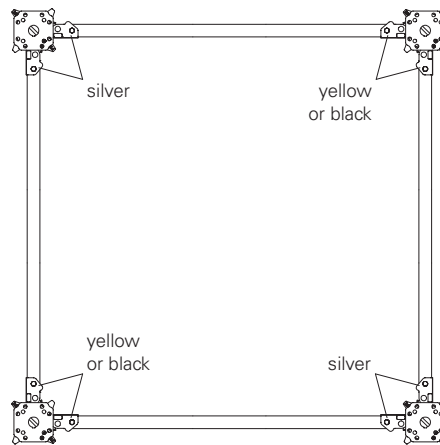

Fig. A2.08

Use of Frames ≤ MP MRK 90

Frames ≤ MP MRK 90 must be mounted on the Inner Tube in the opposite direction to the Outer Tube, to prevent twisting of the tower. Thus the colour of the wedge connections on the tube changes over the height of the tower. (Fig. A2.09a + Fig. A2.09b)

Outer Tube ≤ MP MRK 90

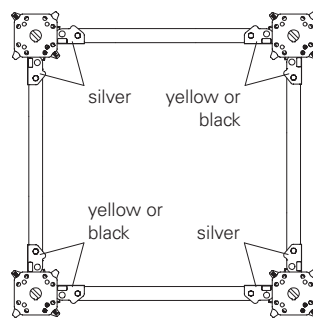

Fig. A2.09a

Inner Tube ≤ MP MRK 90

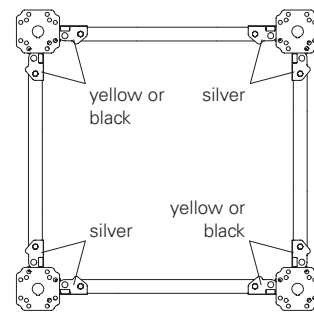
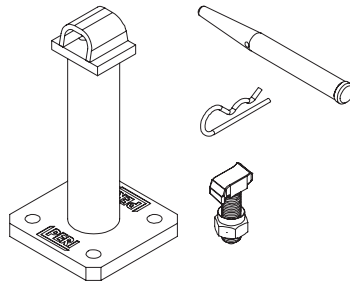

Fig. A2.09b

Compression Brace Head MP/ SRU with Connector MP/SRU



- Always place the bolt head on the MULTIPROP MP.
- Check nuts for tightness.



Assembly

1. Fasten the Compression Brace Head MP/SRU (9) diagonally to the end plate of the MULTIPROP MP (1) using 2x Screw with Nut MP (8). (Fig. A2.10 + Fig. A2.11)
2. Spindle out MULTIPROP MP to the required length.
3. Fit the Compression Brace Head MP/ SRU (9) to the Steel Waler SRU U120 with Fitting Pin $\varnothing 21 \times 120$ mm (19) and Cotter Pin 4/1 ga (20).

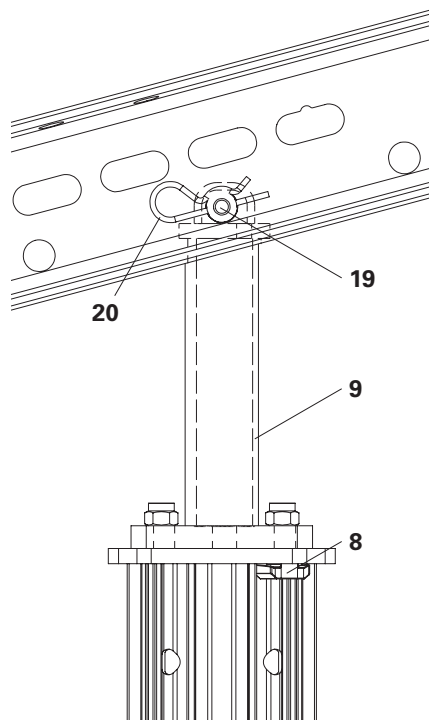

Fig. A2.10

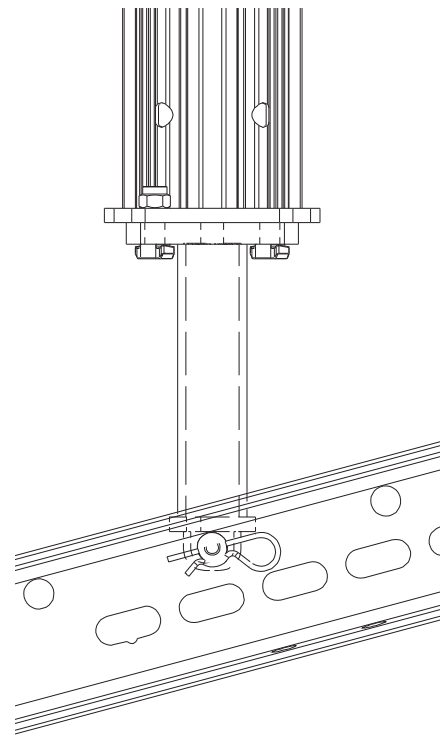

Fig. A2.11



- The Compression Brace Head MP/SRU (9) with Connector MP/SRU (17) is used to brace inclined Steel Walers SRU U120 on shoring towers. (Fig. A2.12)
- The Compression Brace Head MP/SRU (9) can also be used for erecting towers on inclined surfaces. (Fig. A2.13)
- The Compression Brace Head MP/SRU (9) can usually be bolted onto the Main Beam SRU directly.
- The Connector MP/SRU (17) serves as a filler element between the Compression Brace Head MP/SRU (9) and the inclined main beams irrespective of the prop grid.
- Any desired inclination and frame size can be achieved by plugging holes "A" or "B" in the Compression Brace Head MP/SRU (9) and holes 1, 2, 3 or 4 in the main beam for Connector MP/SRU (17). (Fig. A2.12a + Fig. A2.12b)

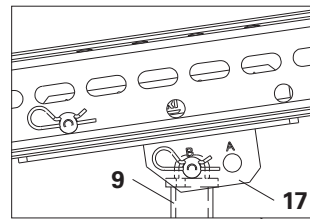

Fig. A2.12a

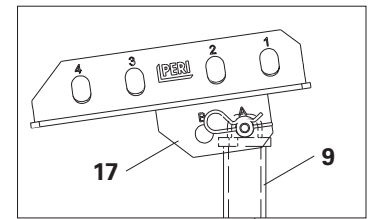

Fig. A2.12b

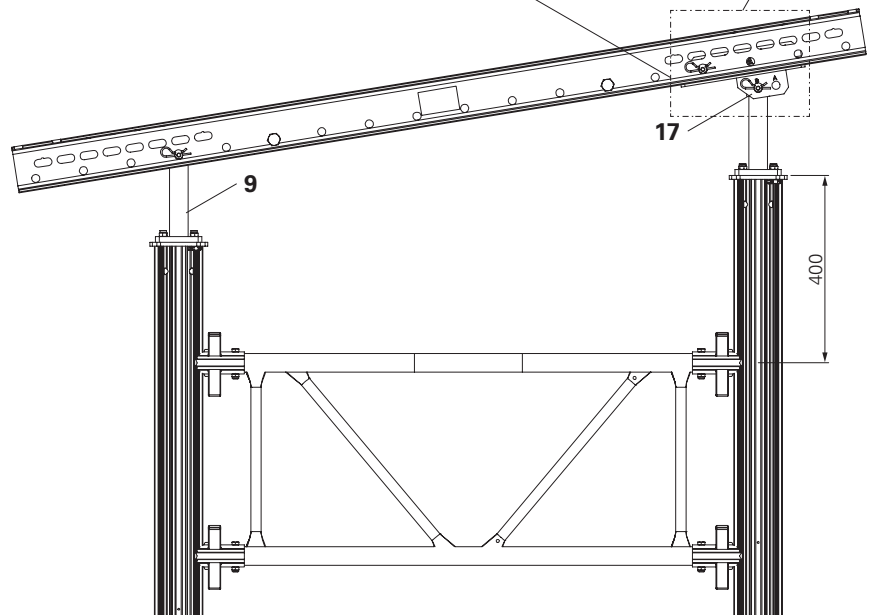

Fig. A2.12



Technical data:

See type test for the PERI Compression Brace Head MP/SRU with MULTIPROP for the permissible load-bearing capacity.

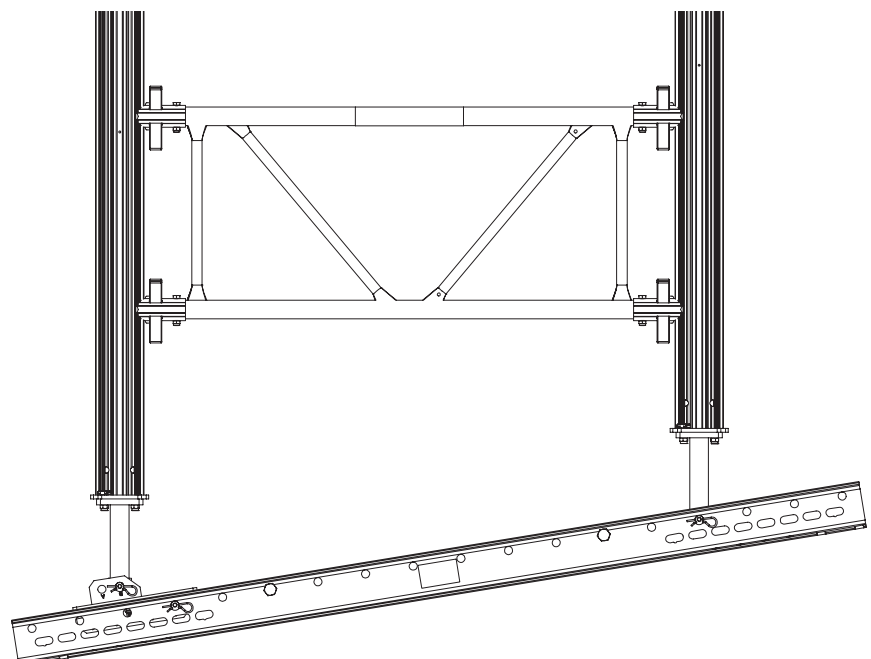

Fig. A2.13

Tilting Base MP MKF

The Tilting Base MP MKF (4) with quick-action clamp coupling can be pivoted on all sides by up to 3°. This means that MULTIPROP MP (1) can be positioned on inclined surfaces. (Fig. A2.14)

Technical data

Max. permissible load-bearing capacity 60 kN.



Only use the Tilting Base MP MKF (4) on stiffened MULTIPROPS MP (1). The first Frame MP MRK (2) can be mounted a maximum of 40 cm above the upper edge of the Base Plate.

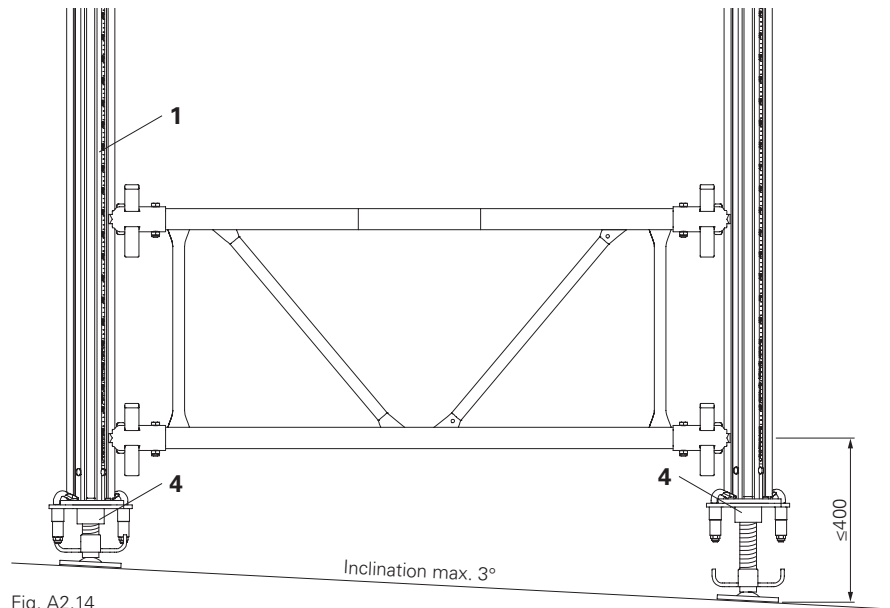

Fig. A2.14

Assembly

1. Insert Centring Pins (4.3) of the Head Plate (4.1) into the drilled holes of the prop Base Plate (1.8) or Head Plate (1.9).
2. Tap the Clamping Claws (4.2) with a hammer over the Base Plate (1.8) or Head Plate (1.9).
→ The Tilting Base MP MKF (4) is connected to the prop. (Fig. A2.15)
3. Spindle the Tilting Base MP MKF (4) to the required dimension using the wing bolt (4.4).
Max. spindle extension: 100 mm.

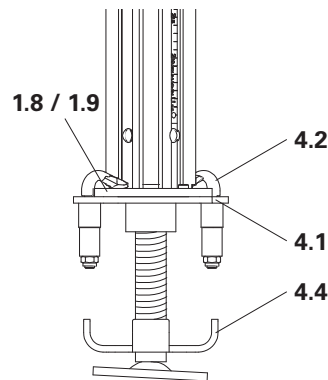

Fig. A2.15

Releasing



Spindle props without load.

1. Open Clamping Claws (4.2) using a hammer.
→ The Tilting Base MP MKF (4) is released from the MULTIPROP MP (1).
2. Remove Tilting Base MP MKF (4).

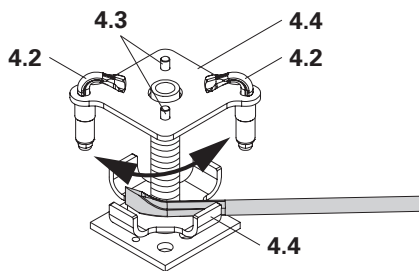

Fig. A2.16

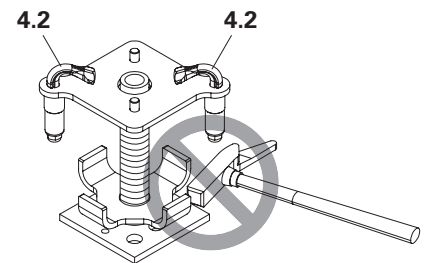

Fig. A2.16a



When under load, the wing bolt can be turned by means of a nail puller (Fig. A2.16)



Never loosen the wing bolt with force. Risk of breakage! (Fig. A2.16a)

Tilting Forkhead MP MKK

Technical data

Permissible load-bearing capacity:
see PERI MULTIPROP System type test.

The Tilting Forkhead MP MKK (5) with quick-action clamp coupling can be pivoted on all sides by up to 3°. It serves to reliably support one or two Formwork Girders GT 24 or VT 20 for non-horizontal slab formwork. (Fig. A2.17)

Alternatively:

Alu Beam MP MB 24 as a main beam.

Assembly

1. Insert the Centring Pins (5.3) of the Base Plate (5.1) into the drilled holes of the Base Plate or Head Plate (1.8/1.9) of the prop.
2. Tap the Clamping Claws (5.2) with a hammer over the Base Plate or Head Plate of the prop.
3. Spindle the Tilting Forkhead MP MKK (5) to required dimension using the wing bolt (5.4).
Max. spindle extension: 100 mm.
(Fig. A2.18)

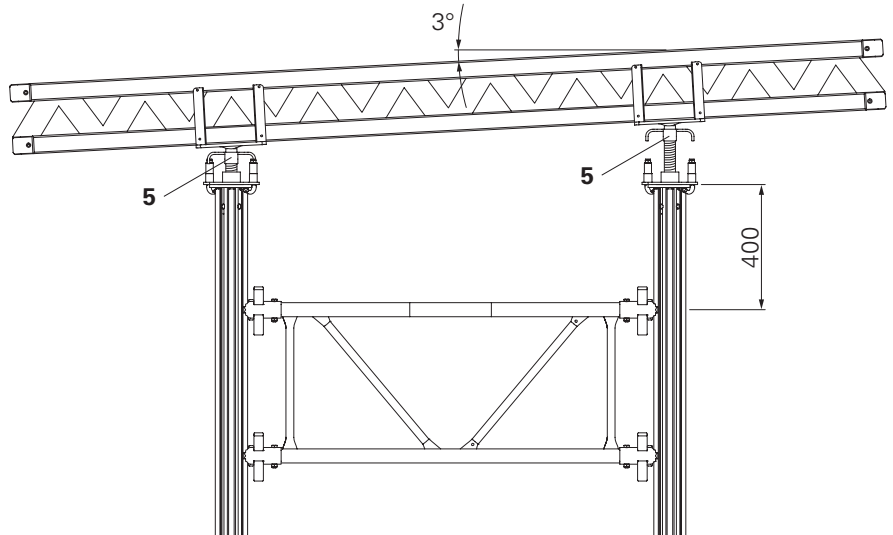

Fig. A2.17



- Safely transfer any horizontal forces that occur.

Releasing



Spindle props without load.

1. Open Clamping Claws (5.2) using a hammer.
→ The Tilting Forkhead MP MKK (5) is released from the MULTIPROP MP (1).
2. Remove the Tilting Forkhead MP MKK (5).

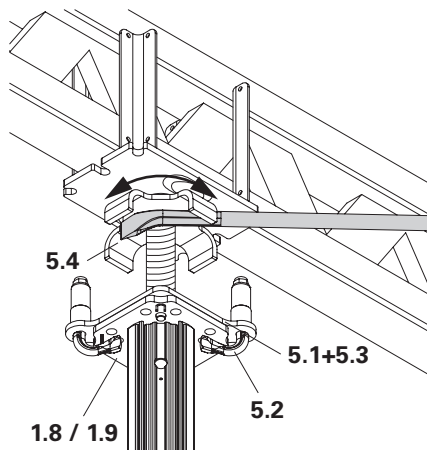

Fig. A2.18

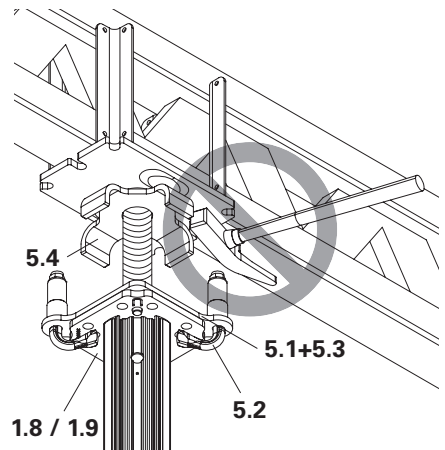

Fig. A2.18a



When under load, the wing bolt can be turned by means of a nail puller. (Fig. A2.18)



Never loosen the wing bolt with force. Risk of breakage! (Fig. A2.18a)

Base MP 50



If the Base MP 50 is used, this must be verified on a project-specific basis.



- Used to extend the MULTIPROP MP by 50 cm.
- Automatic centring of the MULTIPROP MP using Centring Pins.
- The Base MP 50 (3) is connected to the slab prop using two Clamping Claws.
- The MULTIPROP MP can be mounted on the Base MP 50 (3) with the Inner or Outer Tube.

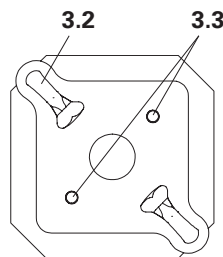

Fig. A2.19a

Assembly

1. Place MULTIPROP MP (1) on Base MP 50 (3).
 2. Centring pins (3.3) engage with the drilled holes of the Base Plate (1.8) or Head Plate (1.9) of the MULTIPROP MP (1). (Fig. A2.19a)
 3. Hit Clamping Claws (3.2) with a hammer over the Base Plate or Head Plate of the MULTIPROP MP (1). (Fig. A2.19)
- Base MP 50 (3) is connected to MULTIPROP MP (1).



Is the full surface of both Clamping Claws resting on the Head and Base Plates?

Releasing



Spindle props without load.

1. Open Clamping Claws (3.2) using a hammer.
2. Remove Base MP 50 (3).

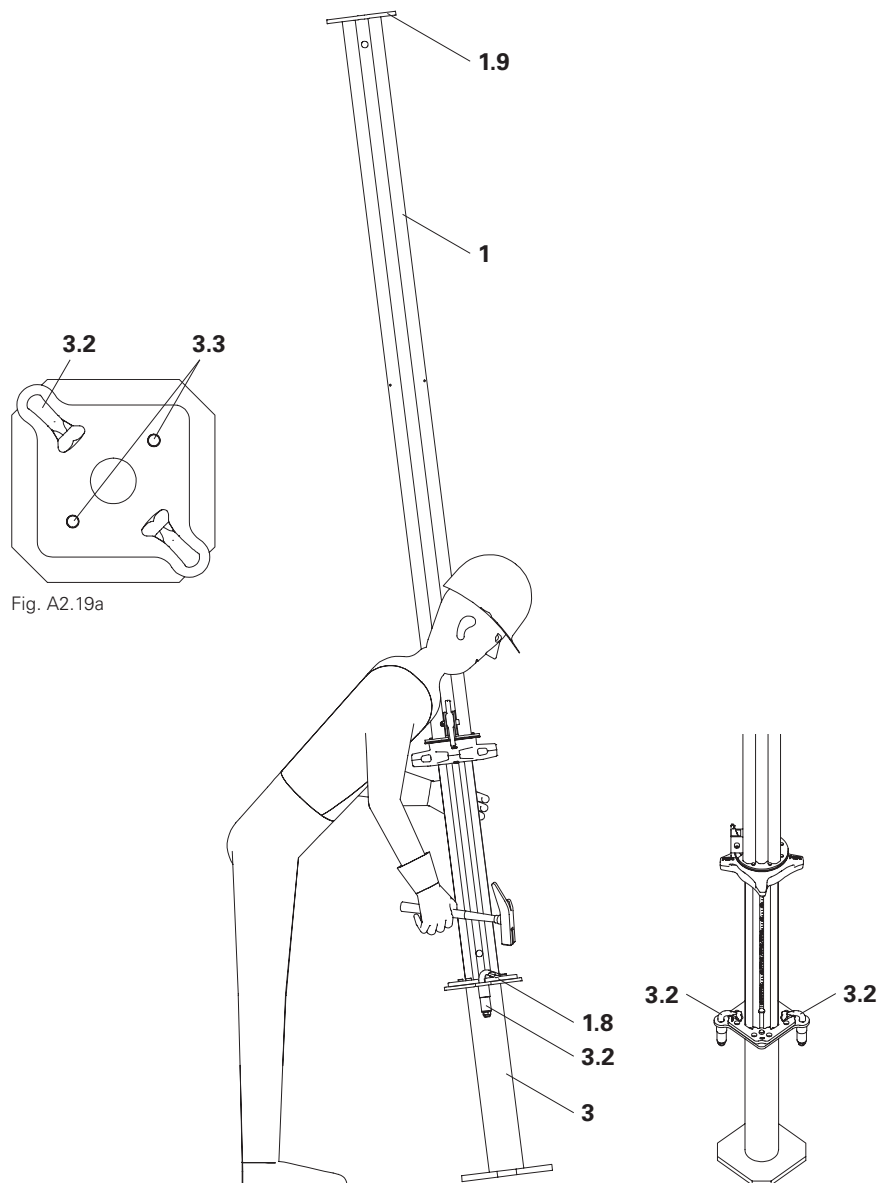

Fig. A2.19

Assembly with 4 legs

For horizontal assembly, a flat and even assembly area is required.



Preparation

1. Adjust the length of the MULTIPROP MP (1), see Section "A1 MULTIPROP Individual Prop" on page 15.
2. Pre-position MULTIPROP MP (1) and Frame MP MRK (2) on the ground:
 - The Inner Tubes (1.2) of the top and bottom props are pointing outwards. This means that any unevenness in the ground can be more easily compensated and the formwork can be levelled.
 - The Base Plates (1.8) must rest on the ground with one edge surface. (Fig. A3.01a)

- The prop joints are positioned on one level. Constantly monitor the alignment of the prop axes to avoid costly corrections.
- With rectangular-shaped shoring towers, the wider frame is positioned on the ground. (Fig. A3.01)
- The number and position of the MULTIPROP MP (1) and the Frames MP MRK (2) must correspond to the respective structural arrangement of the type test.



Checking assembly is easier with the measuring scale (1.6) facing towards the centre of the tower. (Fig. A3.01b)

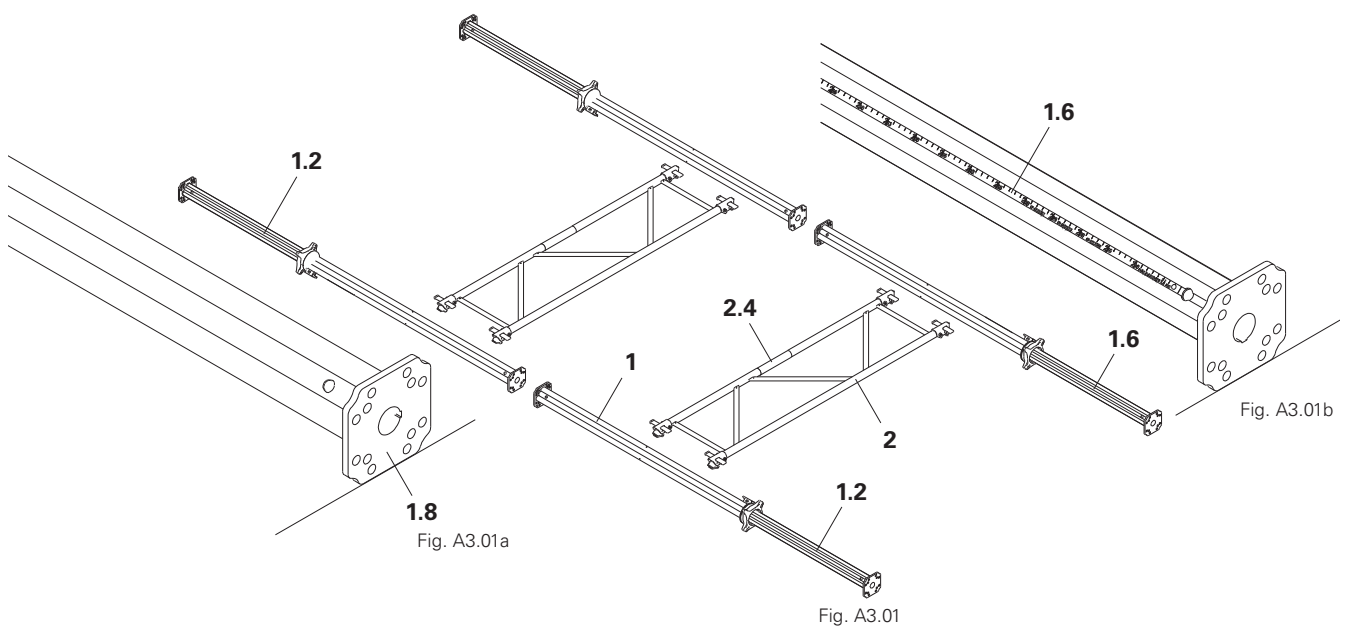

Assembling the tower

1. Connect the MULTIPROPS MP (1) to each other.
2. Mount the Frame MP MRK (2).
The wider frame is positioned on the ground. (Fig. A3.02)

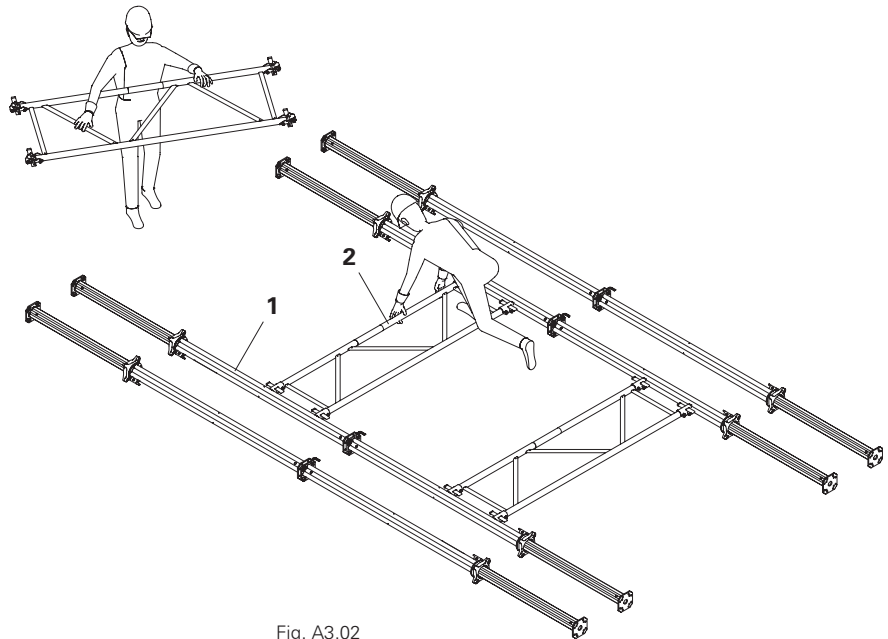

Fig. A3.02

3. Mount the lateral Frame MP MRK (2).
(Fig. A3.03)

- Yellow or black to yellow or black and silver to silver.
- Close the wedges in the direction of the underside of the tower.



Check the colour of the wedge connections as well as the wedge direction.



The text on the stickers (2.4) is legible from the subsequent erection area.

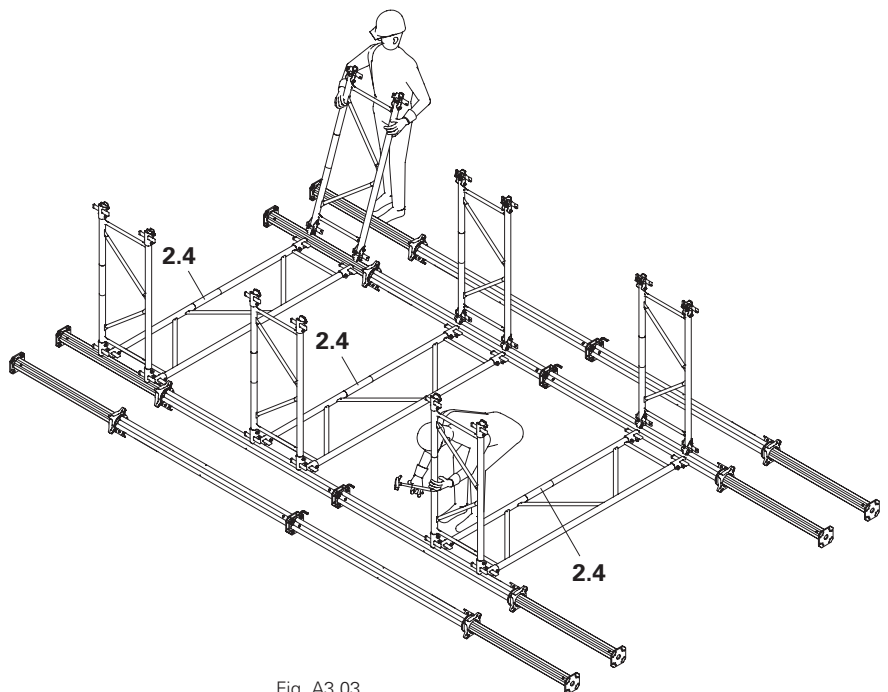

Fig. A3.03

4. Insert the second pair of props into the open wedge connections of the Frames MP MRK (2).
 5. Close wedge connections and hammer in wedges.
 6. Mount the upper Frames MP MRK (2). (Fig. A3.04)
- The tower has now been assembled.



Before erecting, ensure that all adjusting nuts are resting against their respective rubbing plates. Are the Securing Hooks closed?



- With larger units, the upper MULTIPROPS MP (1) can be inserted individually. Connect the MULTIPROPS MP (1) to each other before connecting to the Frames MP MRK (2).
- For towers with heights >7.0 m, connect a Scaff. Tube $\text{Ø}48.3 \times 3.2$ mm (10) as a horizontal brace at half the tower height to the Frames MP MRK (2) using Swivel Couplers AF $\text{Ø}48/48$ mm (14) to ensure that the cross-sectional shape is maintained. (Fig. A3.05)

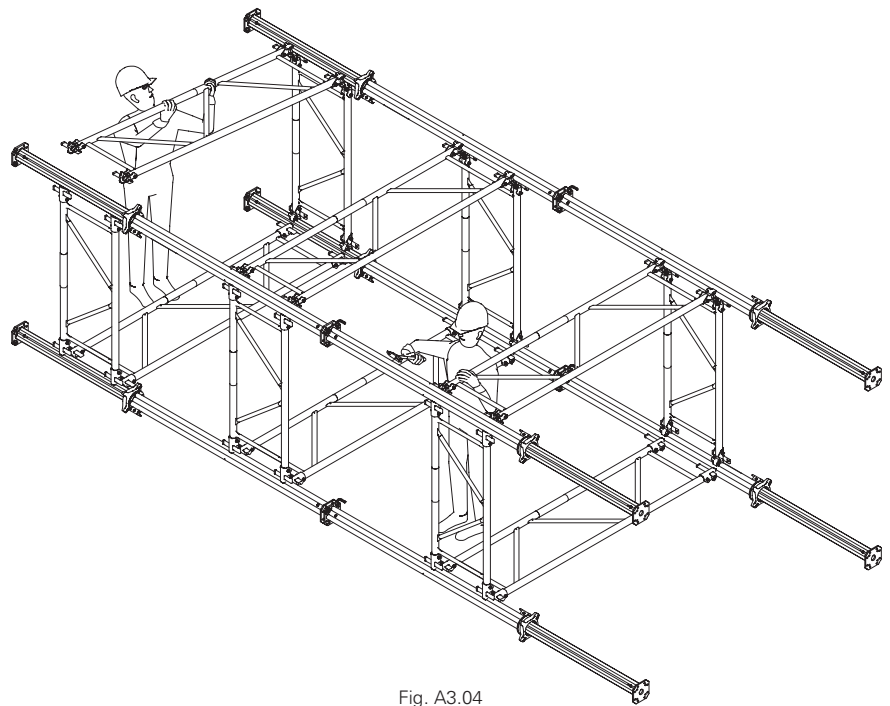

Fig. A3.04

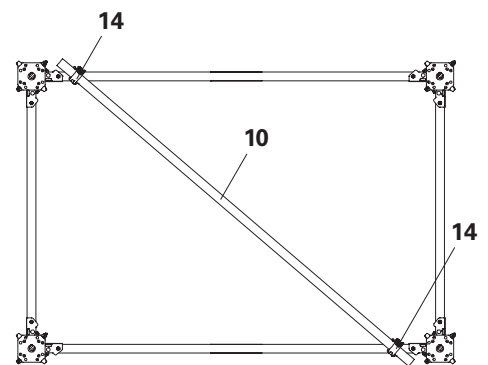

Fig. A3.05

Assembly with multiple number of legs



The arrangement instructions for the MULTIPROP Frames MRK should be followed, see Section "A2 MULTIPROP System" on page 16.



The following should also be taken into account:

- The Frames MP MRK (2) must be installed in a consistent "windmill" design.
- Using Scaff. Tubes 48.3x3.2 mm (10) to reinforce the bracing diagonally at half the tower height. (Fig. A3.06)
- Tighten all adjusting nuts (1.4) until they make contact with the rubbing plates (1.7).
- For the lifting unit, fit Scaff. Tubes Ø48.3x3.2 mm (10a) beneath the frame tubes of the upper frame. (Fig. A3.07)

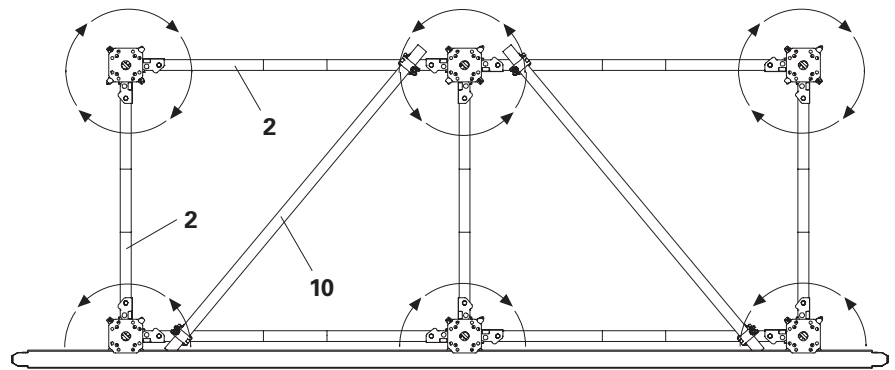

Fig. A3.06

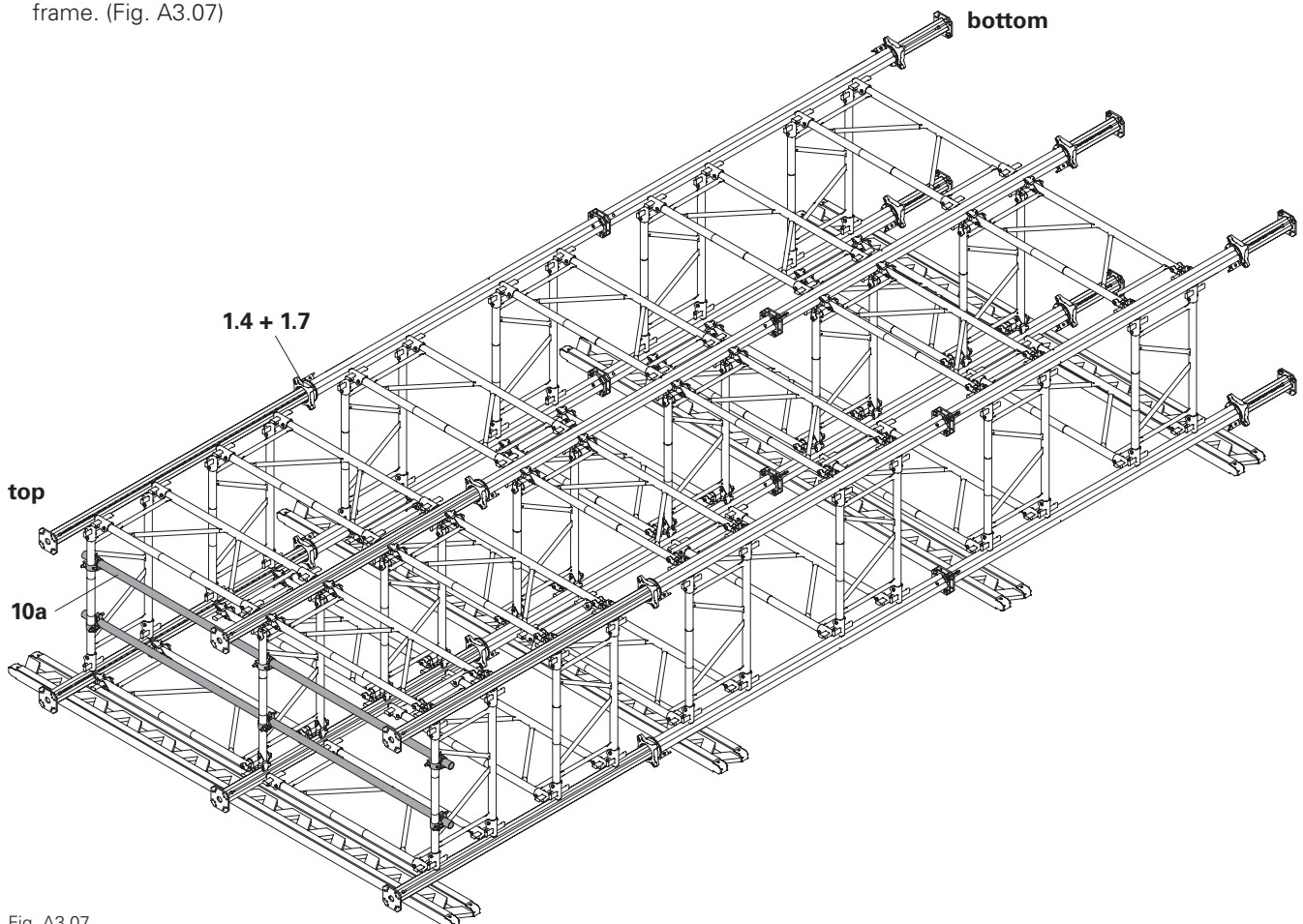

Fig. A3.07

Erecting the tower

Rectangular towers are erected via the shorter side of the frame and rotated around the longitudinal axis.

Rotating the tower around the longitudinal axis

1. Brace the tower in the centre with a horizontal brace, see Fig. A3.05.
2. With a 2-sling lifting gear, attach the tower on one side and symmetrically to the tower height. (Fig. A3.08)
3. Lift tower slightly.
4. Turn tower by 90° and set it down on timber base.
→ The shorter Frame MP MRK (2) is at the top/bottom. (Fig. A3.09)

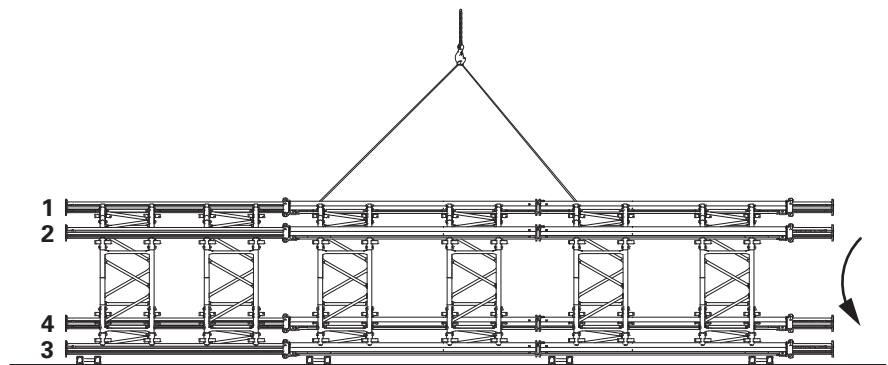

Fig. A3.08

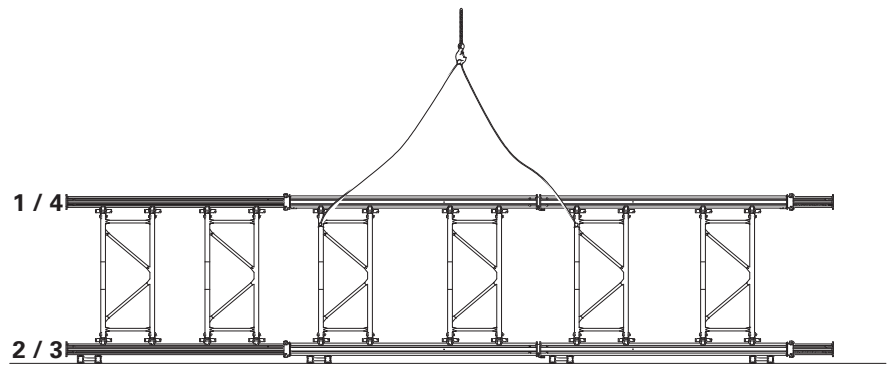

Fig. A3.09



Warning

Heavy load on the crane!
 Tower can come loose and fall down.
 ⇒ Check wedges for tightness!
 ⇒ Do not stand under the suspended load.



- Before erecting, ensure that all adjusting nuts are resting against their respective rubbing plates. Securing Hooks are closed.
- If necessary, secure the tower with temporary Assembly Aids to prevent it from tipping over, e.g. using push-pull props, see Section "A5 Bracing MULTIPROP Towers" on page 32.

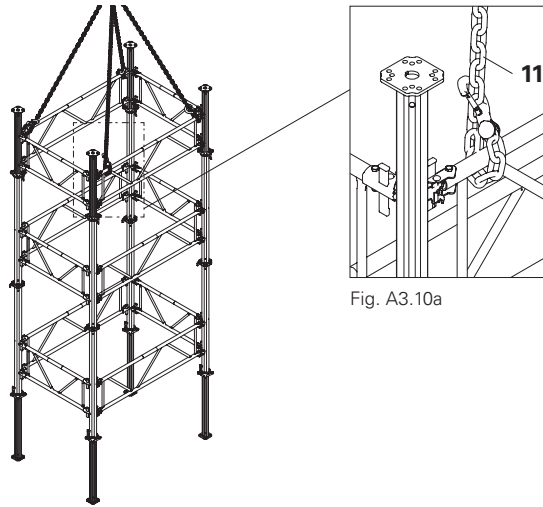

Fig. A3.10

Fig. A3.10a

Tower with 4 legs, with multiple number of legs

1. Fit Brace Connectors MP MR (13) for the temporary Assembly Aid.
2. Insert the Inner Tubes (1.2) of the bottom MULTIPROP MP (1) all the way.
3. Remove the Inner Tubes (1.2) of the top MULTIPROP MP (1).
 → This prevents large bending moments from occurring and the tower from hitting the Base Plate (1.8).
4. Attach slings:
 hook 4-sling lifting gear (11) into two opposite Frames MP MRK (2) of the topmost frame row or scaffolding tubes (Fig. A3.10 + Fig. A3.10a)
5. Erect tower and align.
6. Extend Inner Tubes (1.2) up to the required length and align so that the tower stands upright.
7. Mount the missing Frames MP MRK (2).
8. Secure the tower to prevent it from tipping over.
9. Detach lifting gear.
 (Fig. A3.11 – Fig. A3.11b)

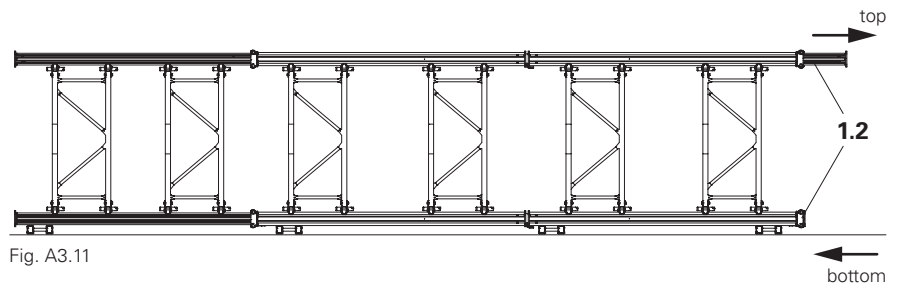

Fig. A3.11

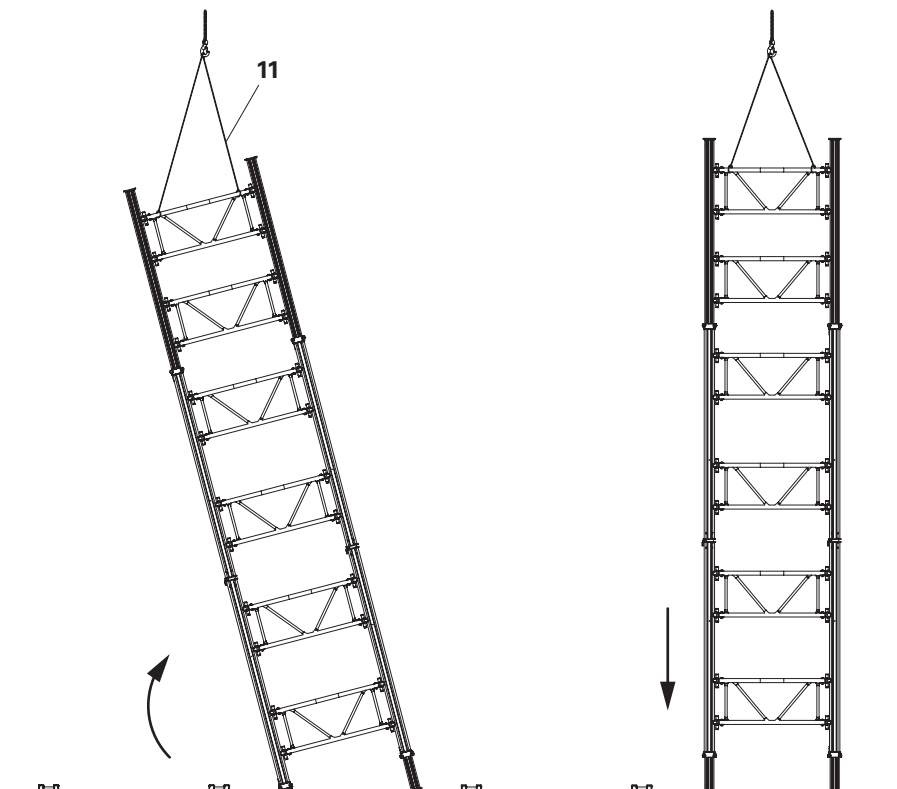

Fig. A3.11a

Fig. A3.11b

First level

If horizontal assembly is not possible due to reasons of space or other circumstances, erection can take place vertically.



Secure props against tipping.

Preparation

1. Adjust the length of the MULTIPROP MP (1), see Section "A1 MULTIPROP Individual Prop" on page 15.
2. Make the necessary Frames MP MRK (2) available.

Assembly

1. Set up the MULTIPROP MP (1):
 - Use the Universal Tripod Ø57-120 mm (12) as an assembly aid.
 - Set up the MULTIPROP MP (1) according to the dimension between the Frames MP MRK (2) to be installed.
 - Inner Tubes (1.2) are at the bottom.
 - The measuring scale (1.6) is pointing inwards. (Fig. A4.01)
2. Install Frames MP MRK (2), see Section "A3 Horizontal assembly" on page 24:
 - e.g. use trestles, working scaffolds.
 - Place Frames MP MRK (2) at the designated positions, see plan or type test.
 - Securely fix the wedges (2.3) with a hammer blow from top to bottom. (Fig. A4.02)



The text on the sticker (2.4) is legible from the erection area.

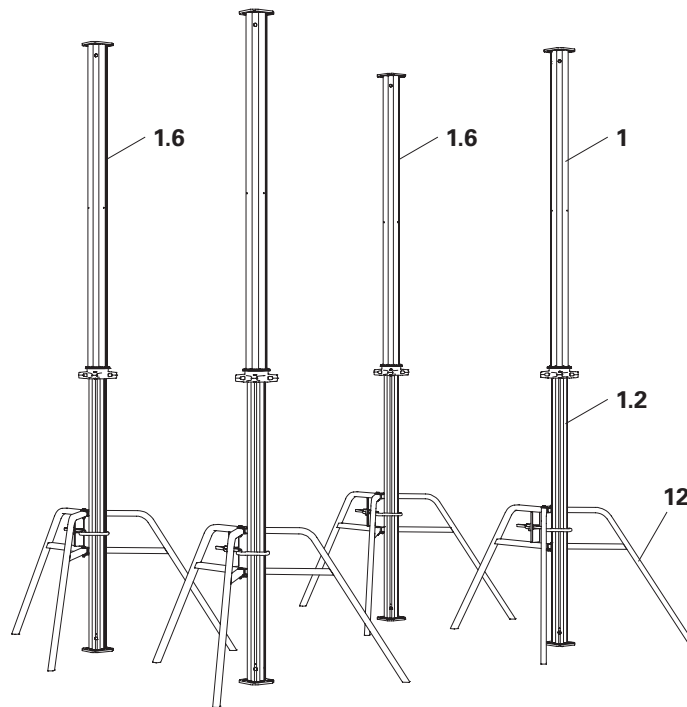

Fig. A4.01

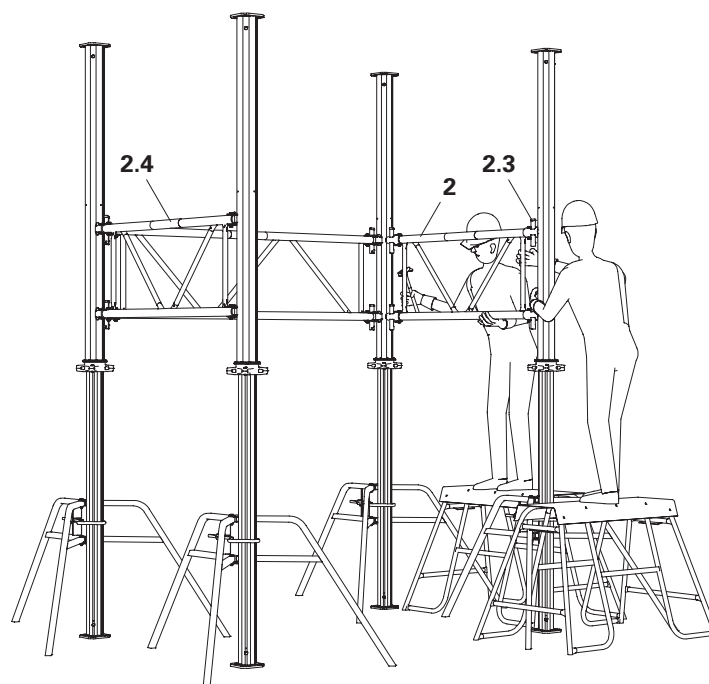

Fig. A4.02

Next level



- Check the stability at all times.
- Use decks with anti-slip protection and sufficient load-bearing capacity as assembly platforms.
- Guardrail spacing for the assembly levels $e \leq 1.0$ m.
- Access, e.g. with Ladder Extendab. MP 220/350 AL.

Assembly

- In order to mount the next prop and frame plane, an assembly level must be installed, e.g. Decks MP (16). (Fig. A4.04)
- If necessary, temporarily secure the tower to prevent it from tipping over, see Section "A5 Bracing MULTIPROP Towers" on page 32.

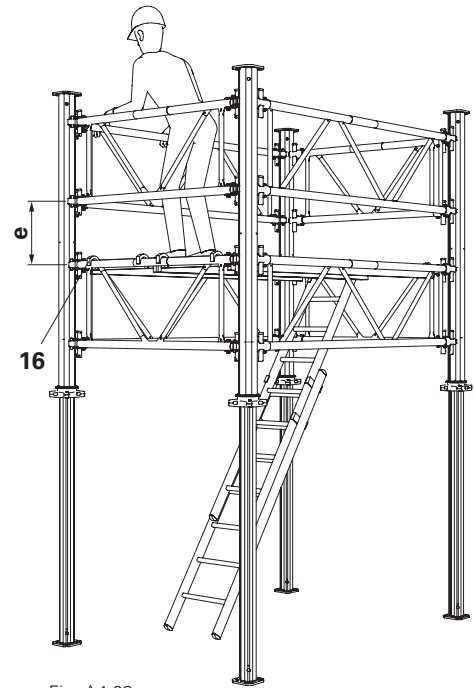

Fig. A4.03

Additional levels

Assemble additional levels in the same way.

Assembly

- Distance between the individual assembly levels in accordance with the risk assessment. Mount guardrails.
- Fit the MULTIPROP MP with the Inner Tube inserted. Spindle out to the required length only after bracing has taken place with Frames MP MRK. (Fig. A4.04)
- Connect MULTIPROP MP: with Connector-2 MP MV or Screw with Nut MP, see Section "A2 MULTIPROP System" on page 16.
- The Frames MP MRK can be used as lateral protection.



Scaff. Tube $\text{Ø}48.3 \times 3.2$ mm can also be used as temporary lateral protection; see Section "B1 Structural scaffolding tube bracing" on page 41. (Fig. A4.04a)

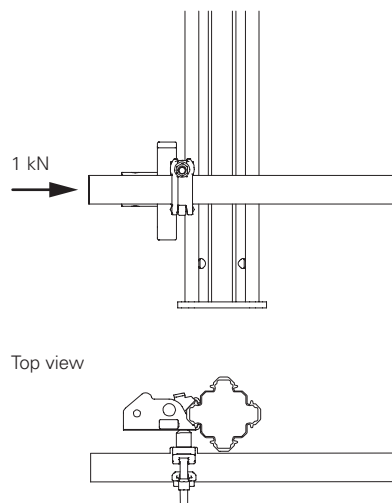

Fig. A4.04a

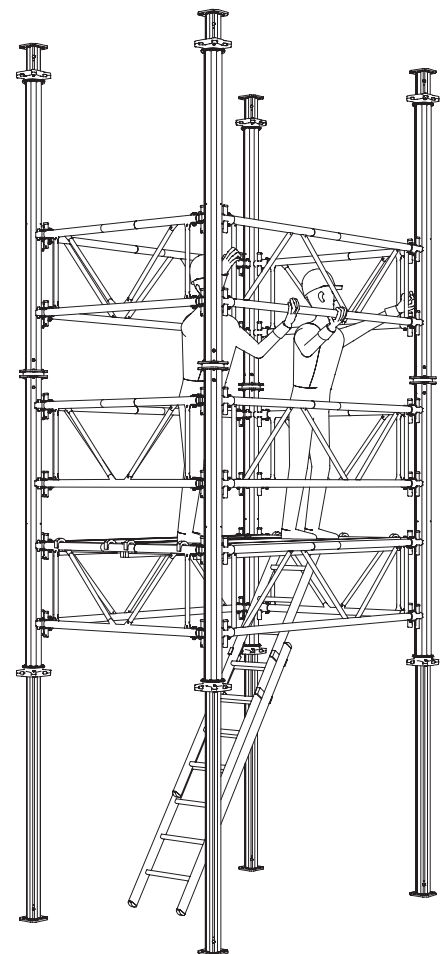

Fig. A4.04

Installing Brace Connector MP MR

The Brace Connector MP MR (13) can be assembled or disassembled temporarily. The Brace Connector MP MR (13) is assembled at the joints of the MULTIPROP MP. This applies equally to all prop arrangements (Inner Tube – Inner Tube, Inner Tube – Outer Tube, Outer Tube – Outer Tube).

The Brace Connector MP MR (13) can be used both on the direct connection with end plates and on the connection with Connector-2 MP MV (7).

Direct connection of the end plates



The end plates must be connected with 2x Screw with Nut MP (8) if the Brace Connector MP MR (13) is only used temporarily.

Assembly

1. Remove 2x Collar Pin Ø12 mm (13.1) from the Brace Connector MP MR (13).
2. Push Brace Connector MP MR (13) over both end plates.
3. Fasten with both Collar Pins Ø12 mm (13.1) and secure with Cotter Pins 3.2/2 (13.2). (Fig. A5.01a)

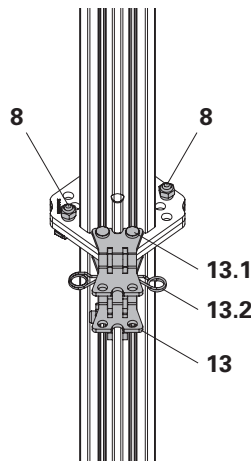

Fig. A5.01a

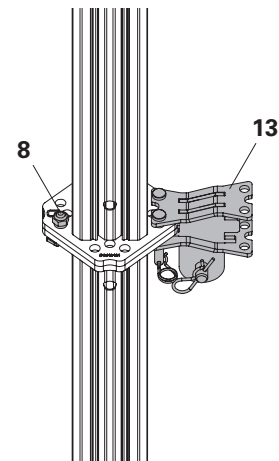

Fig. A5.01b



If the Brace Connector MPR is permanently installed, a Screw with Nut MP (8) on the side opposite the connection is sufficient. (Fig. A5.01b)

Connecting the end plates with Connector-2 MPV

Assembly

1. Remove 2x Collar Pin Ø12 mm (13.1) from the Brace Connector MP MR (13).
2. Push the broader opening of the Brace Connector MP MR (13) over both end plates. Not possible on the Clamping Lever (7.1).
3. Fasten with both Collar Pins Ø12 mm (13.1) and secure with Cotter Pins 3.2/2 (13.2). (Fig. A5.01c)

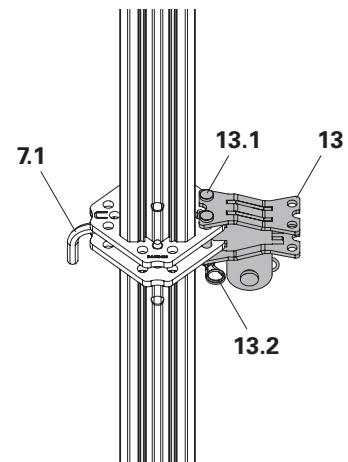
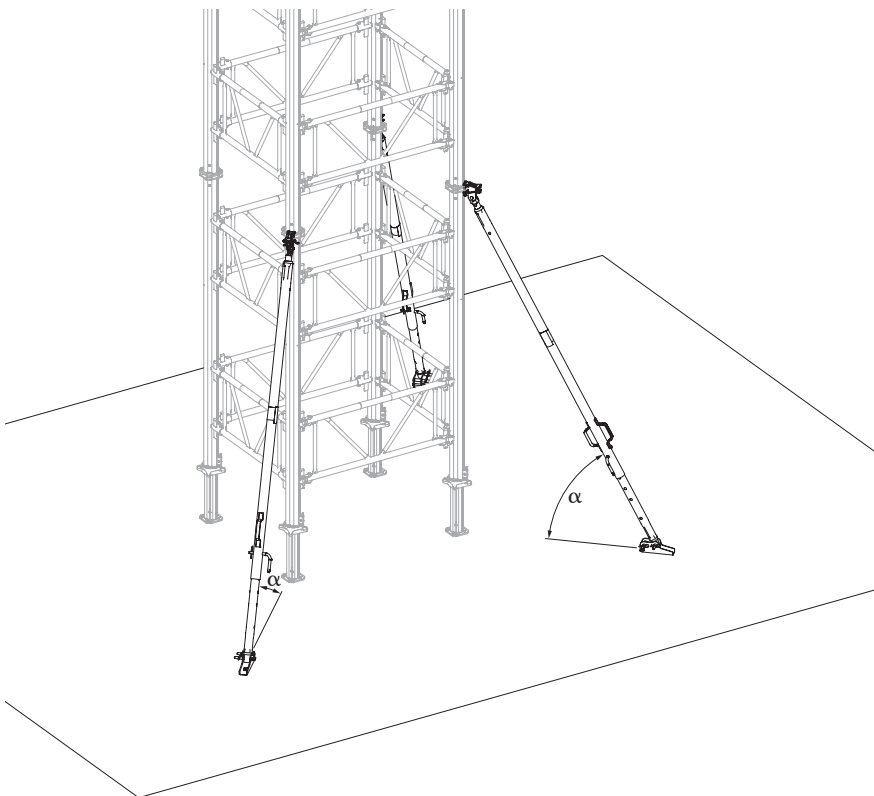

Fig. A5.01c

A5 Bracing MULTIPROP Towers

Permissible load of the Brace Connector MP MR

Connecting the end plates	Angle α [°]	Perm. pressure [kN]	Perm. tensile force [kN]
direct	45	4.4	9.7
direct	60	9.1	9.9
with MP MV	45	8.0	9.1
with MP MV	60	11.9	12.1



Bracing with push-pull props

During assembly and disassembly, the MULTIPROP Towers or units must be secured against tipping over using temporary assembly aids, if necessary.



Warning

Risk of tower tipping!

A tipping tower can result in serious injury or even death.

- ⇒ Brace the units against one another.
- ⇒ For stability, fit 3 Push-Pull Props RS as assembly aids.

Assembly

1. Fix Brace Connector MP MR (13) to the prop joint. (Fig. A5.02a)
2. Fasten the Push-Pull Prop RS with bolts and cotter pins.
3. Fasten the Base Plate-3 for RS to the foundation with a tie bolt.
4. Fix push-pull prop to the Base Plate with bolts and cotter pins. (Fig. A5.02b)
5. Fit additional push-pull props and detach the tower from the crane. (Fig. A5.02)

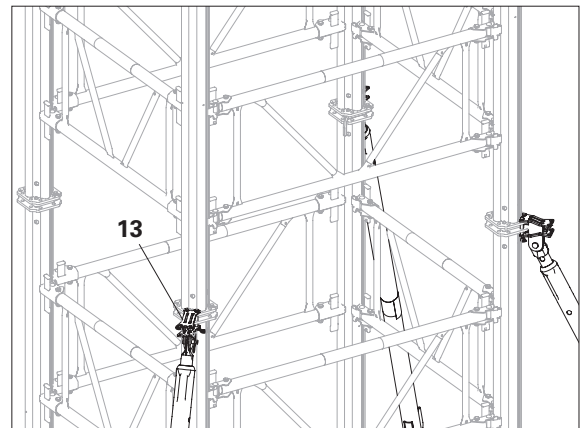

Fig. A5.02a

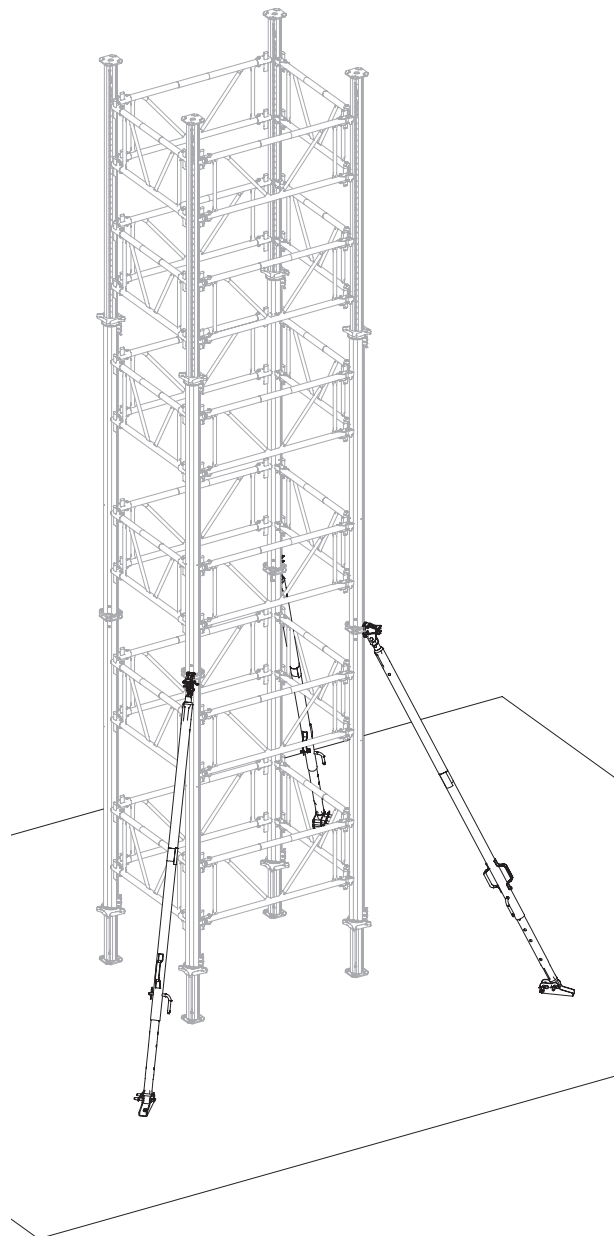

Fig. A5.02

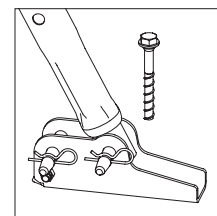

Fig. A5.02b

Supporting in units

Assembly

1. Arrange MULTIPROP Towers in the grid of the Frames MP MRK.
2. Install Frames MP MRK between the towers. (Fig. A5.03)
3. Hammer in wedges.
4. Fit Push-Pull Props RS at the prop joints. (Fig. A5.03a)

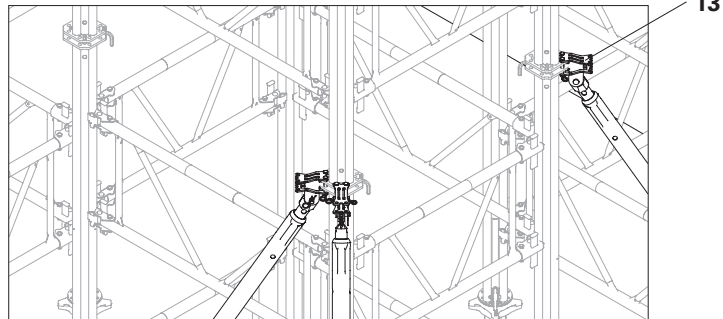

Fig. A5.03a

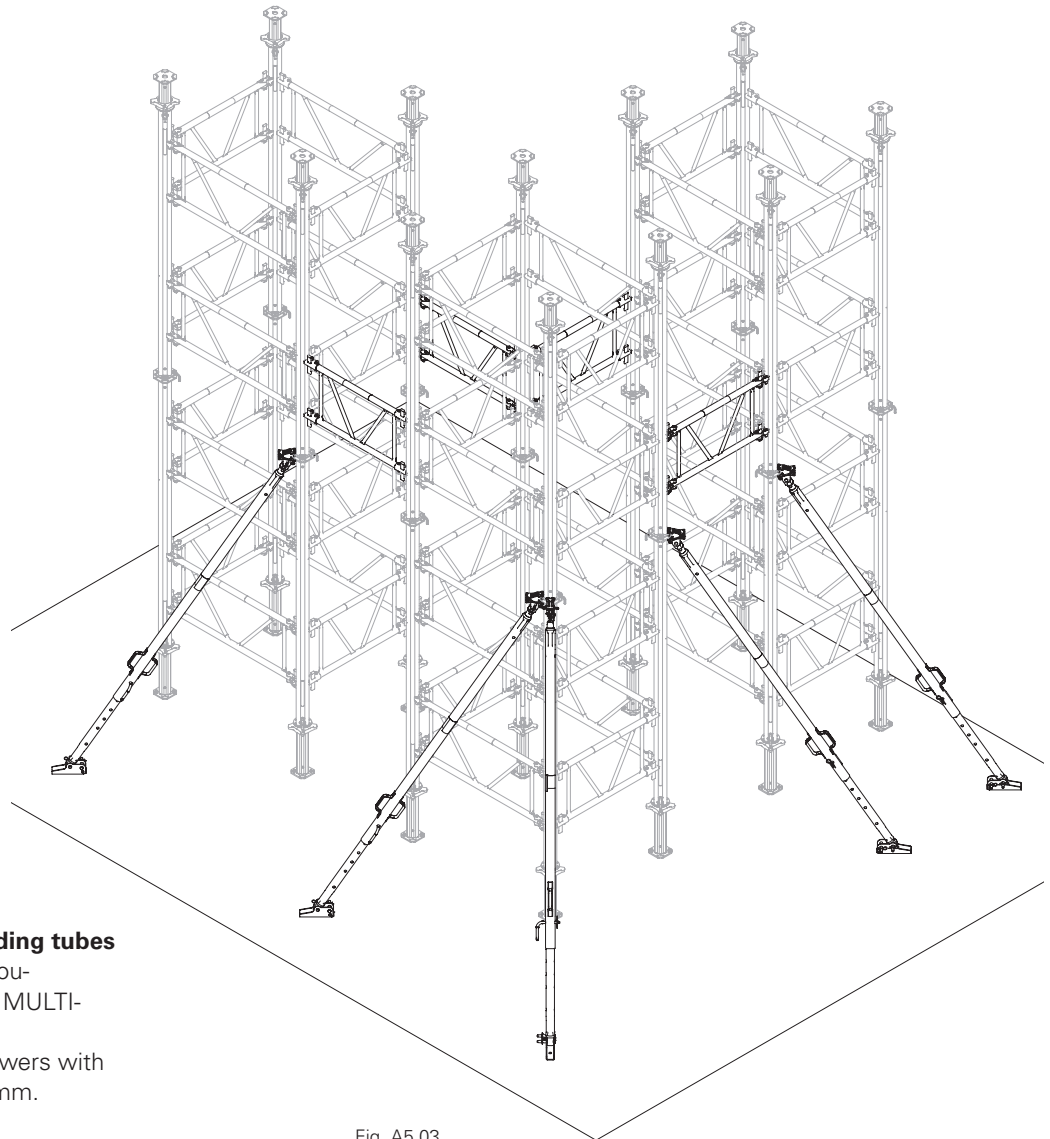

Fig. A5.03

Alternatively:

Connections with scaffolding tubes

1. Fasten the Scaff. Tube Couplers MP MG (15) to the MULTIPROP MP (1).
2. Connect MULTIPROP Towers with Scaff. Tubes $\text{\O}48.3 \times 3.2$ mm. (not shown)

Strap MP U100-U140

In order to transfer high loads, during the assembly of a slab table, instead of twin main beams consisting of Formwork Girders GT 24, Steel Walers SRU can also be connected to the MULTIPROP MP (1) as the main beam. One Strap MP U100-U140 (6) is fitted for each MULTIPROP MP.

Assembly

1. Release Hex. Nut M16 (6.4).
2. Swivel the bracket (6.1) outwards.
3. Guide the Strap MP U100-U140 (6) over the Steel Waler SRU from the top. (Fig. A6.01a)
4. Align the centring plate (6.3) of the main beam (6.2) between the U-sections of the Steel Waler SRU.
5. Swivel the bracket (6.1) back and hook it into the holes in the Base or Head Plate (1.8/1.9) from below.
6. Tighten the Hex. Nuts M16 (6.4). (Fig. A6.01b)

→ The Strap MP U100-U140 (6) holds the Steel Waler SRU on the MULTIPROP MP (1).

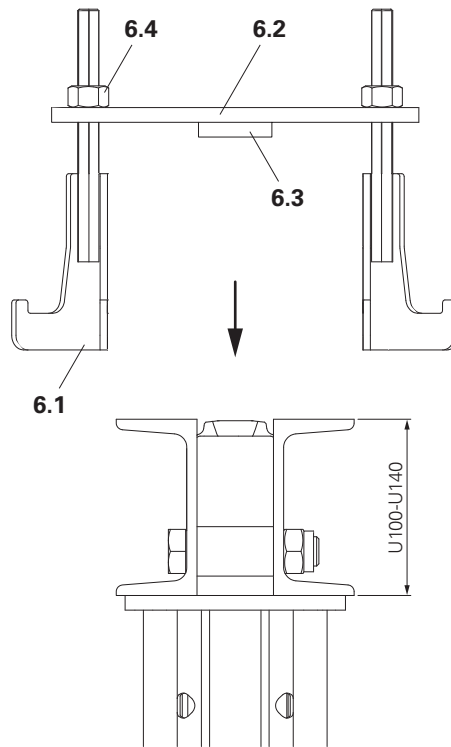

Fig. A6.01a

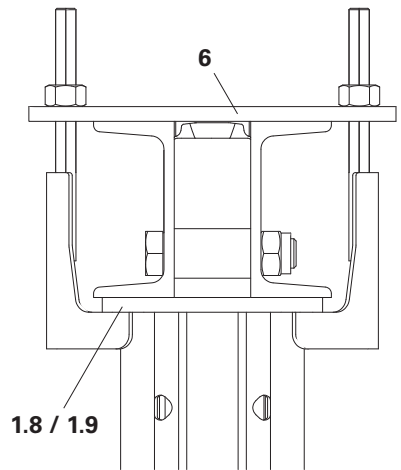

Fig. A6.01b

Releasing

1. Release Hex. Nut M16 (6.4).
2. Pull the bracket (6.1) out of the holes in the Base or Head Plate (1.8/1.9) and remove the Strap MP U100-U140 (6).

Connecting MULTIPROP MP to Alu Beam MP MB 24

For transferring high loads, the Alu Beams MP MB 24 (22) can be used as main beams.

Assembly

Assembly takes place with two diagonally-arranged Straps MP MB 24 (18) and Screw with Nut MP (8). (Fig. A6.02)

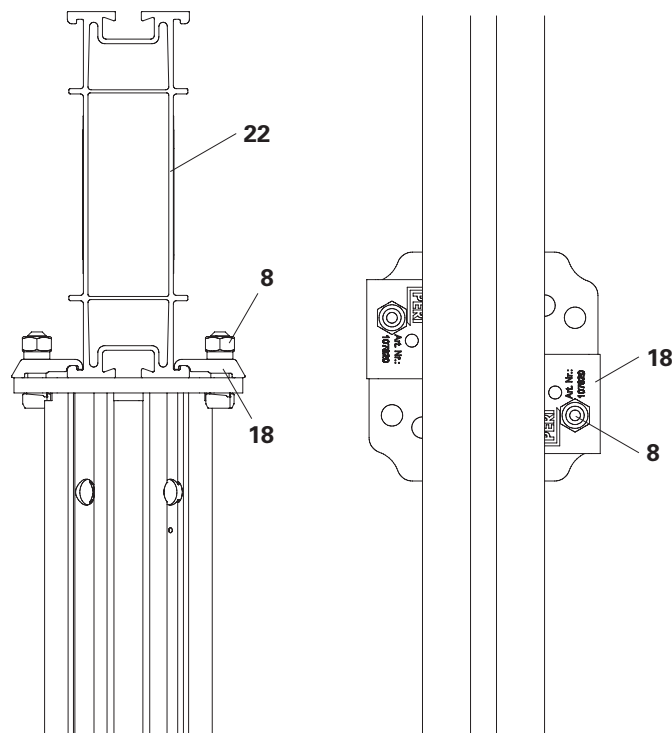

Fig. A6.02

Coupler MP MB 24

The Coupler MP MB 24 (**21**) connects multiple Alu Beams MP MB 24 (**22**) to form a longer unit.

Permissible loads of the connection:
 perm. $M = 8.8 \text{ kNm}$
 perm. $Q = 23.5 \text{ kN}$



- If extended units are used as twin main beams, the Pins $\text{Ø}20 \times 140 \text{ mm}$ ga (**23**) must point outwards. (Fig. A6.05 + Fig. A6.05a)
- When twin main beams are used, the Crosshead 20-24 S is used on the MULTIPROP MP (**1**).
- The joints must be arranged at least 15 cm offset from one another. (Fig. A6.05a)

Assembly

1. Position two Alu Beams MP MB 24 (**22**) at the joint.
2. Insert the Coupler MP MB 24 (**21**). (Fig. A6.03)
3. Insert 4x bolts $20 \times 140 \text{ mm}$ (**23**) into the 1st and 4th holes of the Alu Beams MP MB 24 (**22**) and secure with cotter pins (**20**). (Fig. A6.04a + Fig. A6.04b)

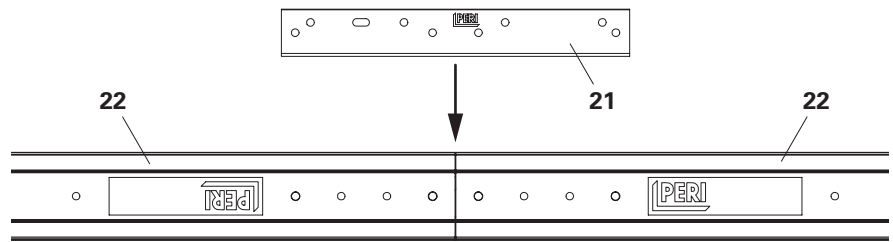

Fig. A6.03

Top view

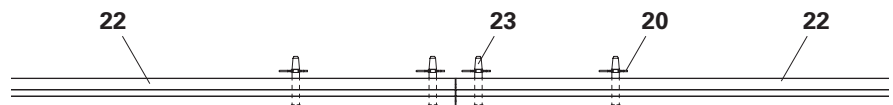

Fig. A6.04a

Lateral view

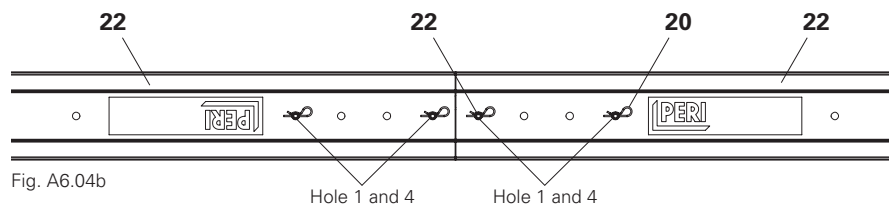

Fig. A6.04b

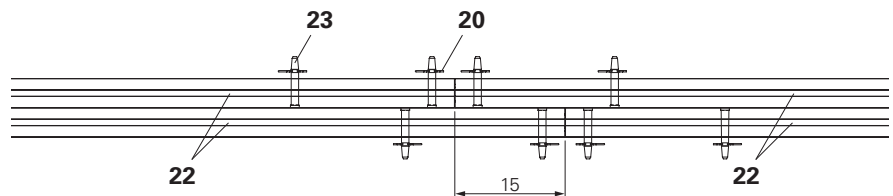

Fig. A6.05a

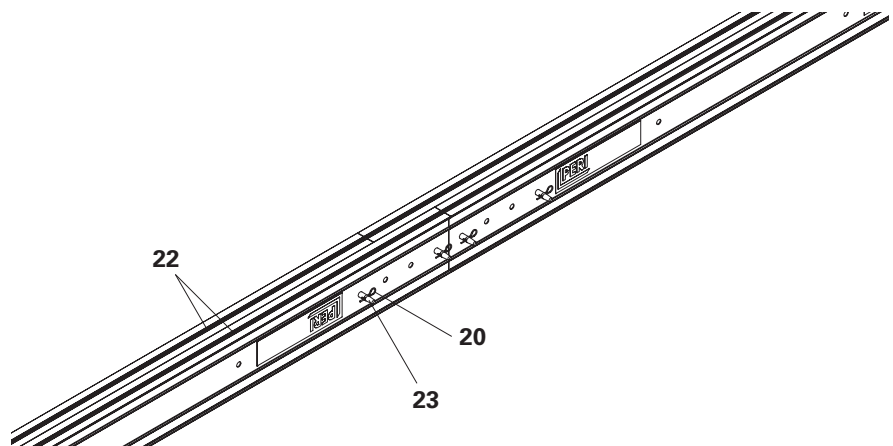

Fig. A6.05



Horizontal dismantling is preferred. Vertical dismantling, however, is possible.



- Ensure stability during dismantling.
- Avoid load concentrations by lowering the MULTIPROP MP evenly.
- Use Wing Nut Spanner HD to release loads > 60 kN.
- Direction of rotation when lowering: Loosen in the direction of the arrow on the adjusting nut (1.4).

Vertical dismantling

1. Temporarily secure the tower to prevent it from tipping over, see Section "A5 Bracing MULTIPROP Towers" on page 32.
2. Loosen the adjusting nut (1.4) and relieve the load by:
 - Hammering on lowering cams (Fig. A7.01a)
 - Using a Wing Nut Spanner HD (Fig. A7.01b)
3. Lower the MULTIPROP Tower.
4. Remove formwork assembly.
5. Dismantle tower from top to bottom. Remove horizontal assembly bracing only when stability has been ensured. (Fig. A7.01)



The Wing Nut Spanner HD allows the adjusting nut to be loosened effortlessly and silently, even in the case of significant support loads. Max. F = 0.95 kN.

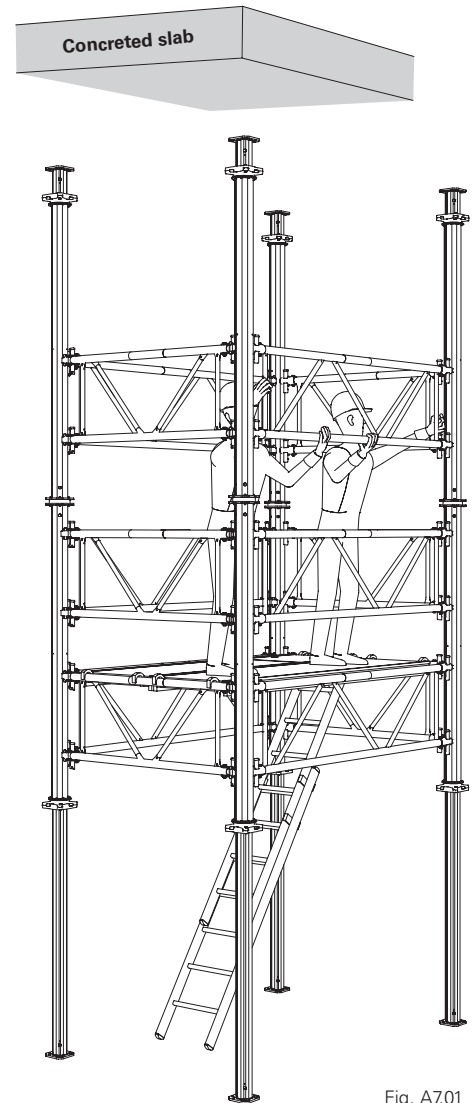

Fig. A7.01

Lower Outer Tube

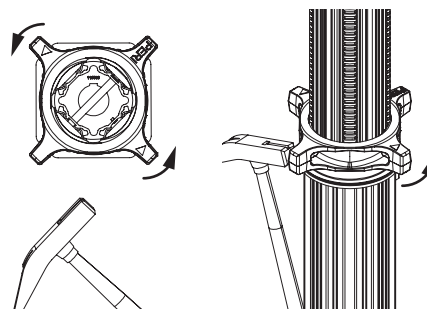

Fig. A7.01a

Lower Outer Tube

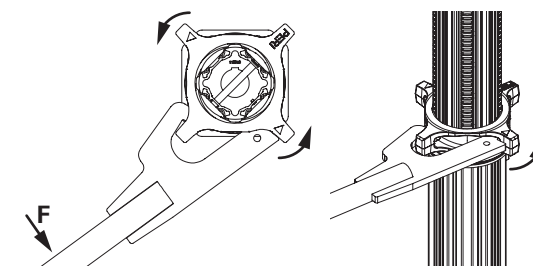

Fig. A7.01b

Horizontal dismantling

1. Move the lowered MULTIPROP Tower out from underneath the concreted slab.
2. Attach 4-sling lifting gear (**11**).
3. Insert the Inner Tubes (**1.2**) on one side, see Section "A3 Horizontal assembly" on page 24.
4. Set the MULTIPROP Tower down on a level dismantling surface. (Fig. A7.02)
5. Dismantle the MULTIPROP Tower.



- If structural bracing has been installed, it is sensible to lower the Towers MP by the uppermost props.
- The Wing Nut Spanner HD allows the adjusting nut to be loosened effortlessly and silently. Max. $F = 0.95 \text{ kN}$.

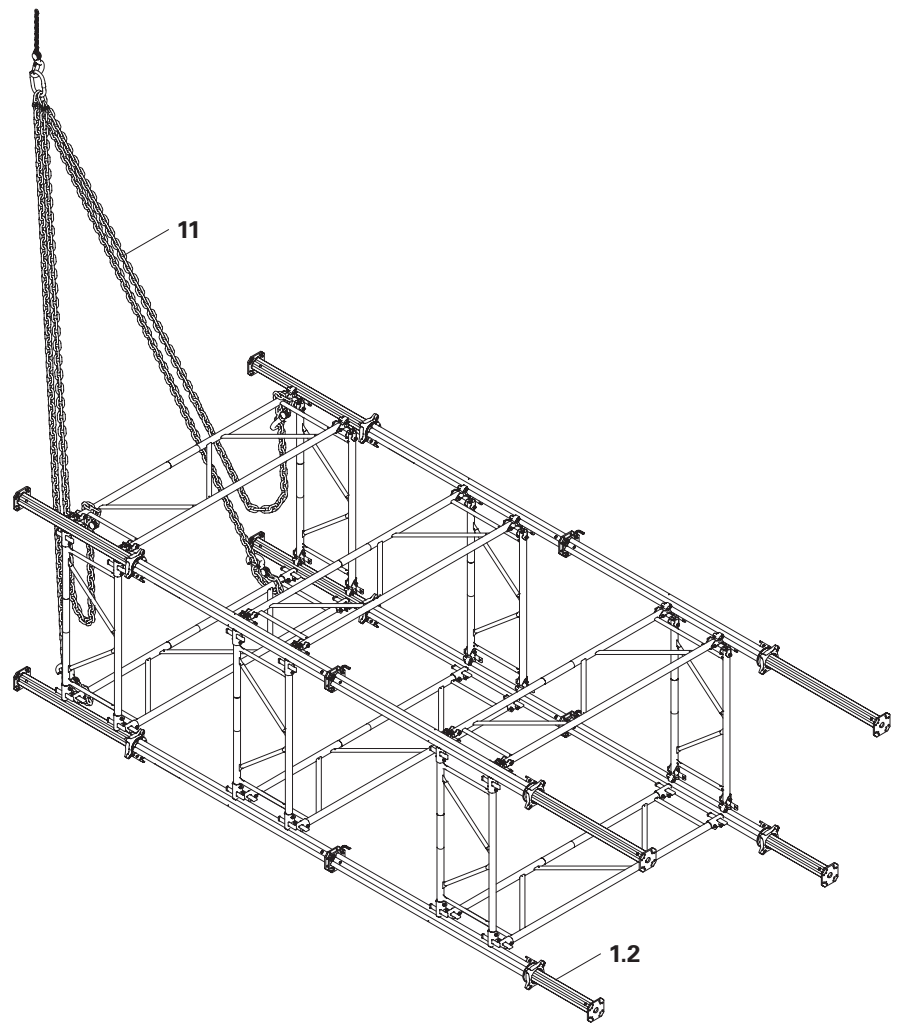

Fig. A7.02



- Refer to the user information for pallets and stacking devices.
- Transportation units must be stacked and secured correctly.



The Securing Hook (**1.3**) prevents the Inner Tube (**1.2**) from slipping out and must be engaged. (Fig. A8.01a)

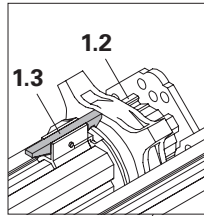

Fig. A8.01a

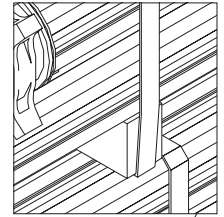

Fig. A8.02a

Transport

- PERI pallets and stacking devices are suitable for lifting by crane or forklift.
- PERI pallets and stacking devices can be moved with the PERI pallet lifting truck.
- PERI pallets and stacking devices can be lifted using both the longitudinal and front sides.

The following are just some examples:

- MULTIPROP MP with support timber and steel band. (Fig. A8.02 + Fig. A8.02a)
- Frame MP MRK (**1**) with steel band. (Fig. A8.04)

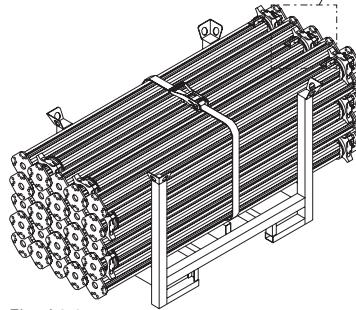

Fig. A8.01

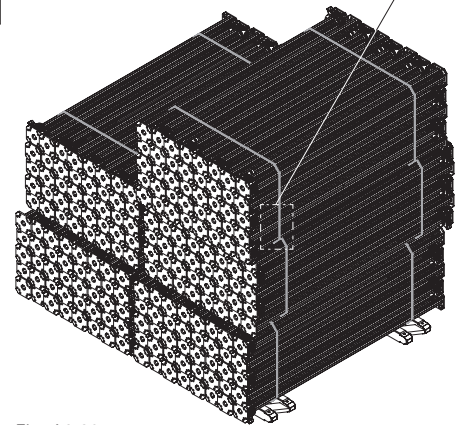

Fig. A8.02

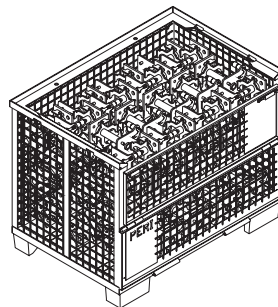

Fig. A8.03

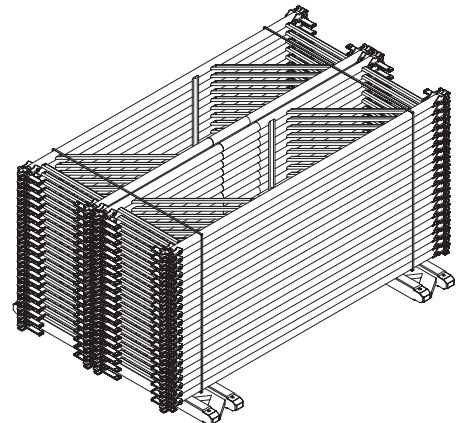

Fig. A8.04

Scaff. Tube Coupler MP MG



Check tilt resistance.



- Horizontal scaffolding tube bracing can be used as an assembly aid.
- The assembly aid consists of Scaff. Tubes $\text{Ø}48.3 \times 3.2$ mm (**10**) and Scaff. Tube Couplers MP MG - A/C or MG - B/D (**15**).
- They are installed in segments and towers, and are designed to stabilise the MULTIPROP MP. (Fig. B.1.01)

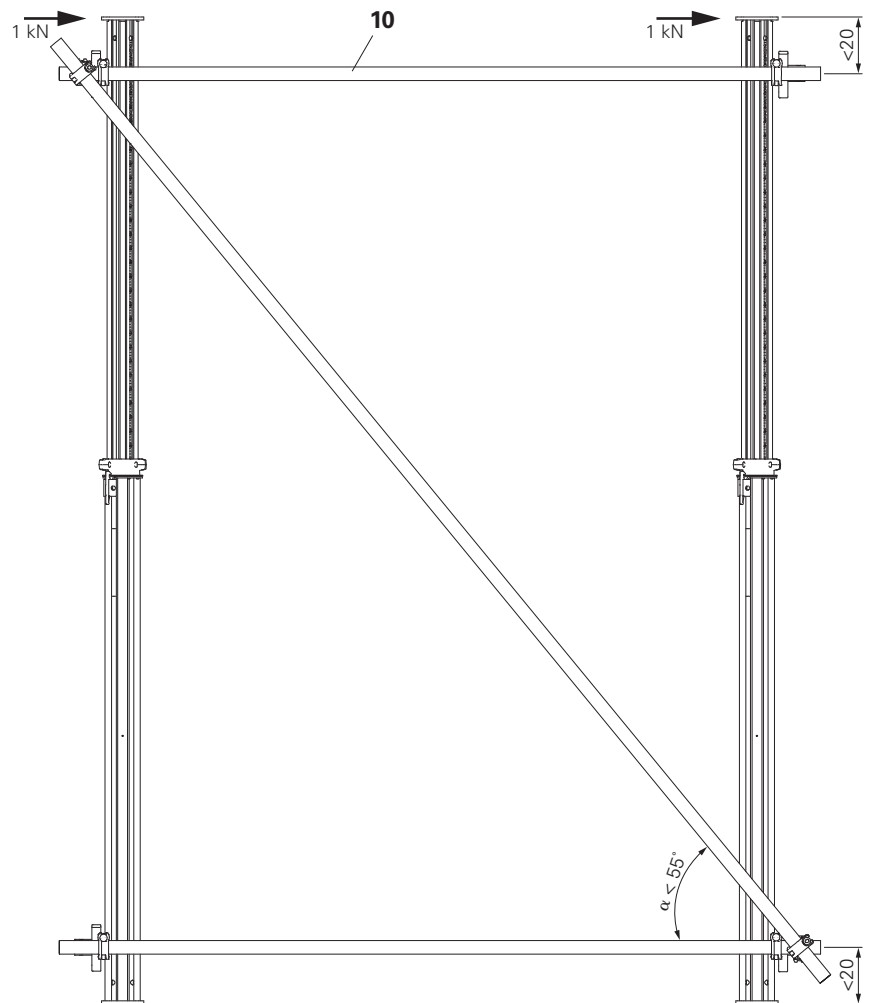

Fig. B.1.01

Application 1:

Scaff. Tube Coupler MP MG for constructive connection of MULTIPROP MP with Scaff. Tubes 48.3×3.2 mm.

Requirements:

- Spacing < 20 cm
- $\alpha < 55^\circ$
- Arrangement of the couplings, see Fig. B.1.02a.

The bracing can carry a horizontal force of $F_H = 1 \text{ kN} + 1 \text{ kN} = 2 \text{ kN}$.

Application 2:

Scaff. Tube Coupler MP MG for transferring small horizontal forces.

A force F_H of 1 kN can be transferred along a horizontal scaffolding tube. (Fig. B.1.02b)

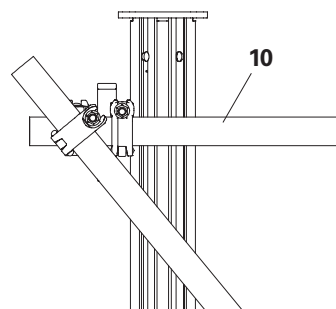

Fig. B.1.02a

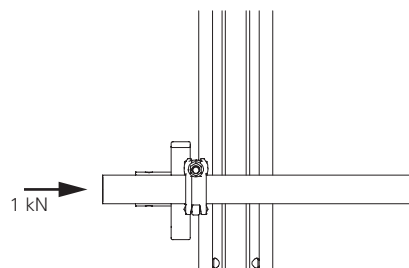
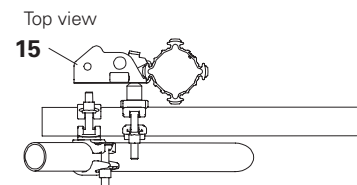
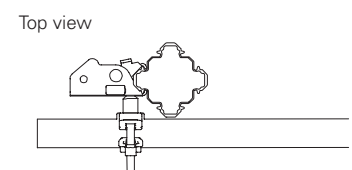

Fig. B.1.02b



Use as scaffold platform beams



The decks can fall down in case of overloading!
A fall can result in serious injury or even death.

- ⇒ Check that wedges are securely fitted.
- ⇒ Do not use frames < MP MRK 120 as platform beams.

As assembly or working platform, decks can be inserted at one frame level. (Fig. B2.01)

We recommend using the Decks MP with/without a hatch and the Ladders Extendab. MP 220/350 AL. The frames are assembled as described in Section "A2 MULTIPROP System" on page 16 .



If Frames MP MRK are used as platform beams, they must be mounted on the Outer Tubes of the MULTIPROP MP.

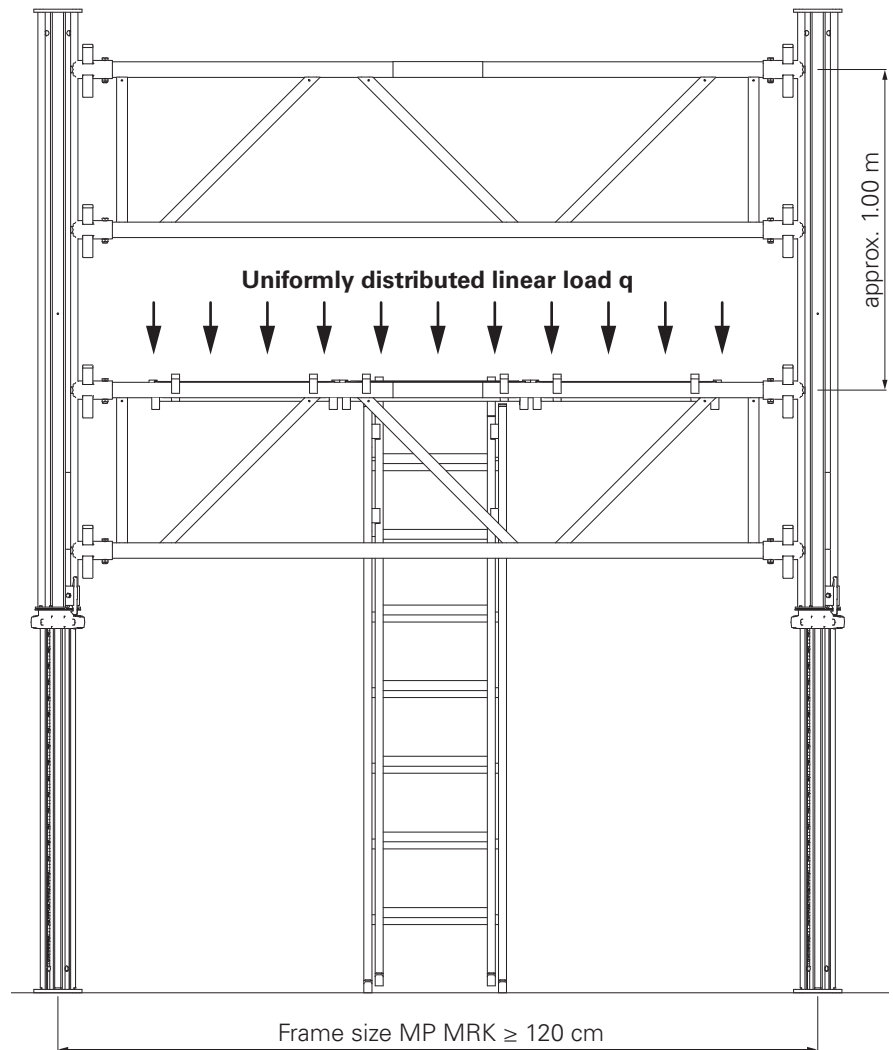

Fig. B2.01

Table Permissible loads for the Frames MP MRK as scaffold platform beams.

Frame size	Perm. uniformly distributed linear load q [kN/m]
MP MRK 350	0.8
MP MRK 296	1.1
MP MRK 266	1.4
MP MRK 237	1.8
MP MRK 230	1.9
MP MRK 225	2.0
MP MRK 201.5	2.6
MP MRK 150	4.0
MP MRK 137.5	4.4
MP MRK 120	5.0

Lowering



- Check stability.
- The lowering process must be divided into small, brief lowering steps. The lowering process must be carried out on all MULTIPROPS MP at the same time. This prevents the MULTIPROP MP from being overloaded or the table from tilting.

Lowering

1. Turn the adjusting nut (1.4) of the MULTIPROP MP (1) and retract the Inner Tube (1.2).
2. Repeat the procedure for all MULTIPROPS MP (1).



Frame MP MRK at Inner Tube: release wedges at two diagonally opposite points. (Fig. B3.01a)



In order to make the lowering procedure easier, the table or tower can be held in position by the trolley with winch unit or the trolley. The MULTIPROP MP can then be spindled off without being subject to any load. (Fig. B3.01)

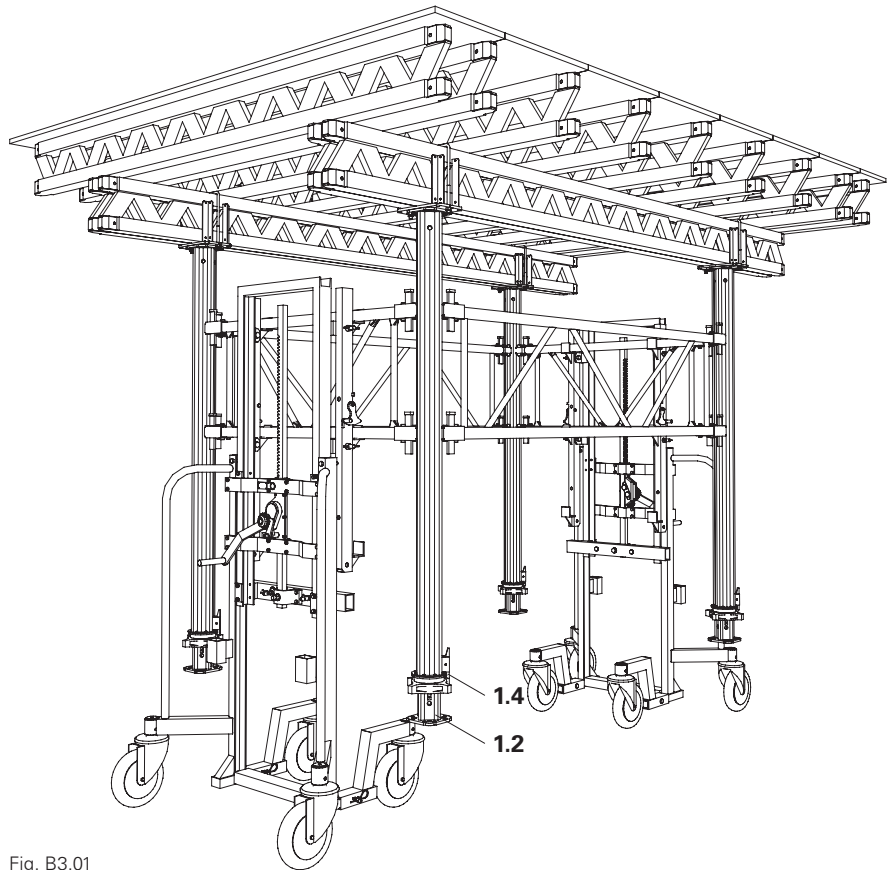

Fig. B3.01

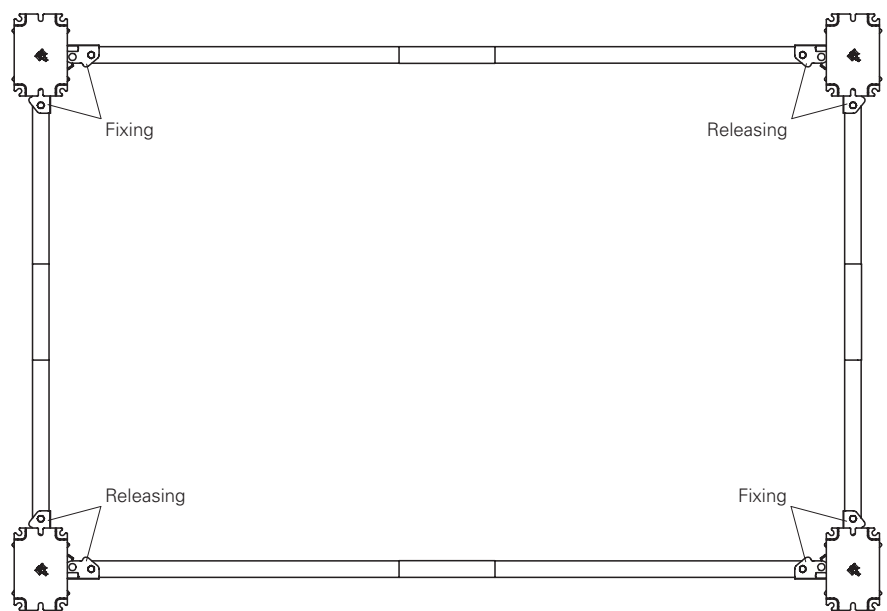

Fig. B3.01a

Moving with the trolley with winch unit



- Observe the instructions for use for the trolley with winch unit.
- Moving unit may tip over.

Moving

1. Position two trolley with winch units in the centre of the narrow frame sides of the shoring for each table or tower.
2. Support the Frames MP MRK using the MULTIPROP Adaptors.
3. Uniformly raise the table or tower with the winches.
4. Move the table or tower.

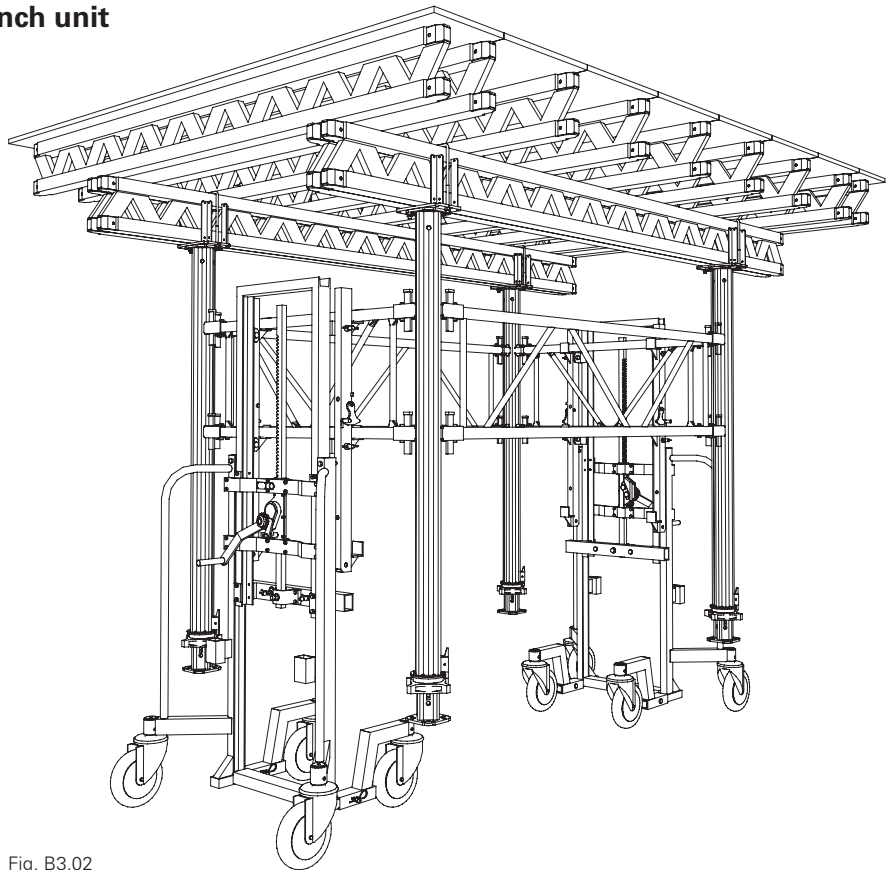

Fig. B3.02

Moving along with pole



The slab tables can be brought into their exact position using two \varnothing 16 mm reinforcement bars (24) or one \varnothing 16 mm reinforcement bar (24) and a stable pole (25).

Moving

1. Insert the reinforcement bar \varnothing 16 mm (24) into the lower holes of the MULTIPROP MP.
2. Move the slab table with a second \varnothing 16 mm reinforcement bar (24) or pole (25). (Fig. B3.03)

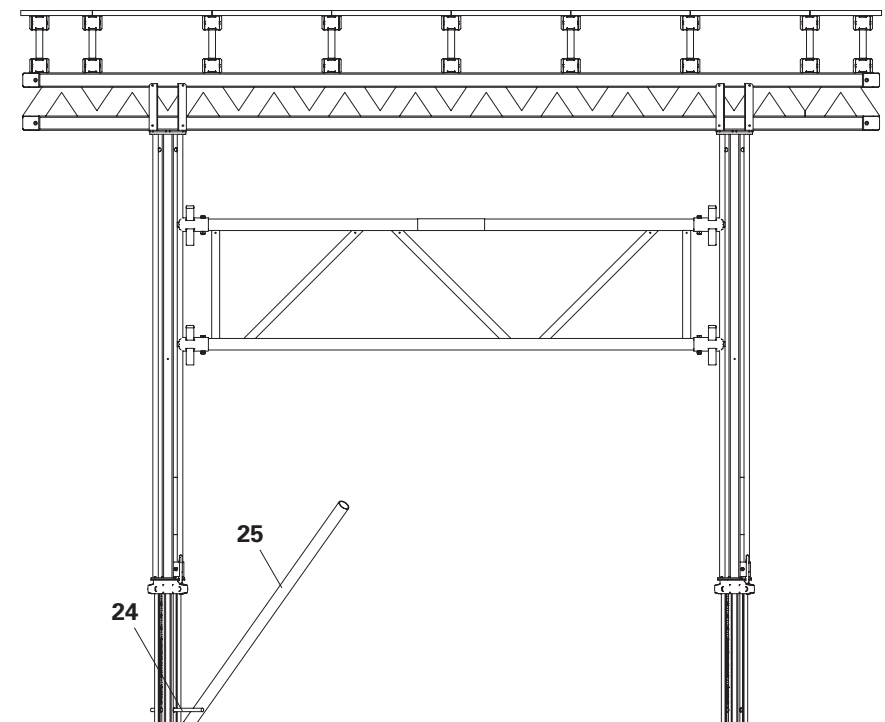

Fig. B3.03

Tables



- The load-bearing capacity of the shoring towers in the MULTIPROP System depends crucially on the position of the Frames MP MRK.
- The values are exclusively available in the relevant current version of the type test.

MULTIPROP System



Art no.	Weight [kg]		min. L [mm]	max. L [mm]
MULTIPROP MP				
027288	10,200	MULTIPROP MP 120	800	1200
027289	15,400	MULTIPROP MP 250	1450	2500
027290	19,500	MULTIPROP MP 350	1950	3500
027291	24,700	MULTIPROP MP 480	2600	4800
027305	34,500	MULTIPROP MP 625	4300	6250

Slab prop made of aluminium. Used as individual prop as well as in combination with Frames MP MRK to form towers.

Notes

Permissible load: see PERI Design Tables.

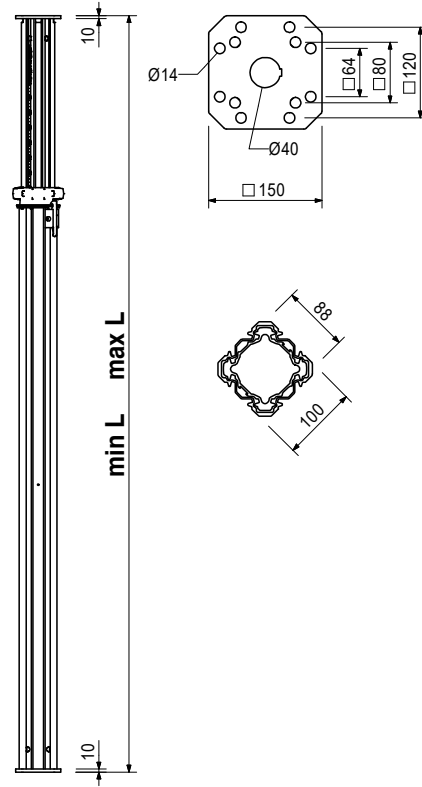

Art no.	Weight [kg]		L [mm]	X [mm]
Frames MP MRK ST				
028390	9,820	Frame MP MRK 62.5 ST	545	625
028400	10,100	Frame MP MRK 75 ST	670	750
028330	11,300	Frame MP MRK 90 ST	820	900
028340	14,000	Frame MP MRK 120 ST	1120	1200
028380	15,400	Frame MP MRK 137.5 ST	1295	1375
028350	16,300	Frame MP MRK 150 ST	1420	1500

Bracing frame for MULTIPROP.
 For connecting to Outer and Inner Tube.
 With captive wedge coupling.

Notes

L = Loading Length
 X = Axis Length

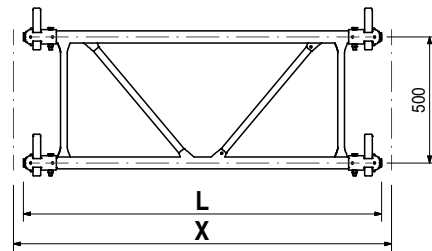
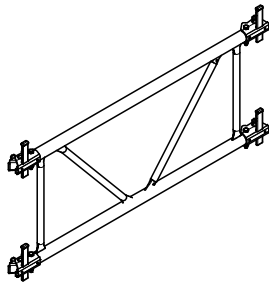

MULTIPROP System

Art no.	Weight [kg]		L [mm]	X [mm]
Frames MP MRK AL				
028460	11,600	Frame MP MRK 201.5 AL	1935	2015
112719	11,800	Frame MP MRK 210 AL	2020	2100
028360	12,400	Frame MP MRK 225 AL	2170	2250
028470	12,500	Frame MP MRK 230 AL	2220	2300
028480	12,700	Frame MP MRK 237 AL	2290	2370
028490	13,900	Frame MP MRK 266 AL	2580	2660
028370	14,900	Frame MP MRK 296 AL	2880	2960
117358	17,000	Frame MP MRK 350 AL	3420	3500

Bracing frame for MULTIPROP.
 For connecting to Outer and Inner Tube.
 With captive wedge coupling.

Notes

L = Loading Length
 X = Axis Length

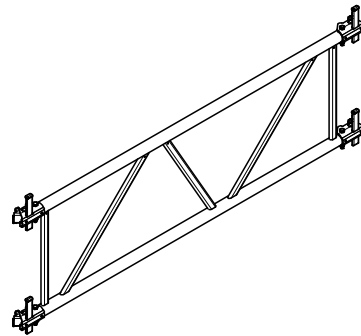
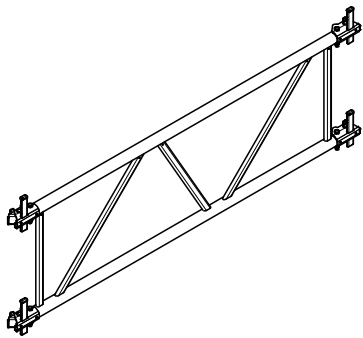

Art no.	Weight [kg]	
Decks MP		
107169	12,000	Deck MP 150X60
107170	18,000	Deck MP 225X60

Mounting surface for assembly on Frame MP.

Notes

Permissible load 2.0 kN/m².

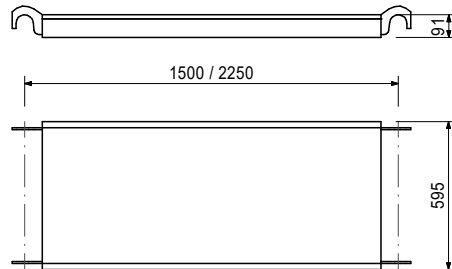
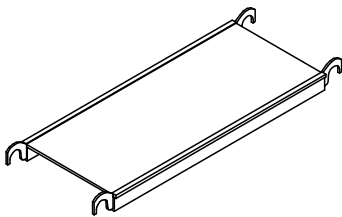

MULTIPROP System

Art no. Weight [kg]

Decks MP with Hatch

107171	12,500	Deck MP 150x60 with Hatch
107172	18,500	Deck MP 225x60 with Hatch

Mounting surface for assembly on Frame MP. Self-locking hatch for access ladder.

Notes

Permissible load 2.0 kN/m².

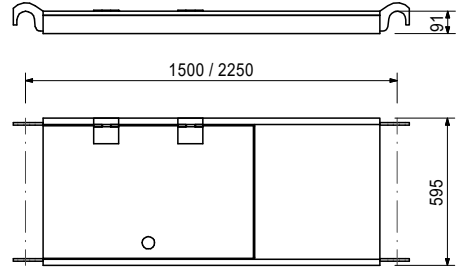
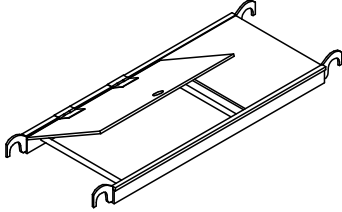

Art no. Weight [kg]

107173	9,000	Ladder Extendab. MP 220/350 AL
--------	-------	---------------------------------------

As access for Towers MP. Mounted to Platform MP with Hatch.

Notes

Extension length 2.20 - 3.50 m.

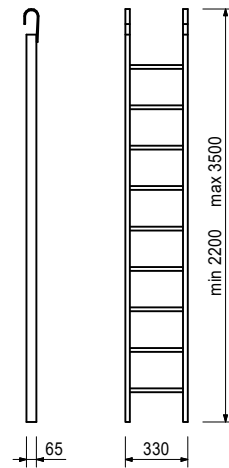

Art no. Weight [kg]

022027	3,600	Wing Nut Spanner HD
--------	-------	----------------------------

For easy release of Head Spindle HDK 45, Head Spindle TR 110-80/55 and the MULTIPROP Slab Prop.

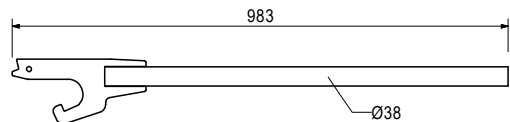
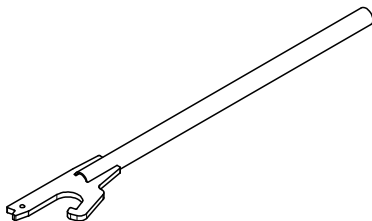

MULTIPROP System

Art no. Weight [kg]

027310 8,950 **Base MP 50**

For use with slab props with an end plate thickness of 6 – 10 mm. With clamped quick-release fastener.

Notes

Permissible load: see PERI Design Tables.

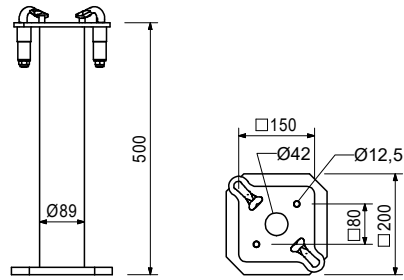
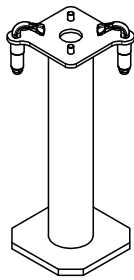

Art no. Weight [kg]

027297 8,750 **Tilting Forkhead MP MKK**

For tilt-resistant support of one or two Formwork Girders GT 24 or VT 20. Can be pivoted by 3° in all directions. With clamped quick-release fastener.

Notes

Separate design information on request.

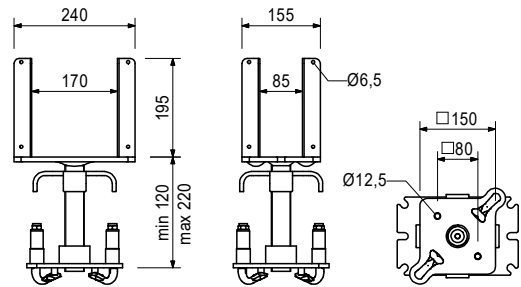
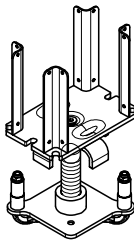

Art no. Weight [kg]

Crossheads 20/24 ga

027890 3,080 **Crosshead 20/24 ga**

028680 3,190 **Crosshead 20/24 S ga**

With or without self-locking coupling.

For tilt-resistant support of one or two Formwork Girders GT 24 or VT 20.

Notes

Required hole diameter of the prop end plate Ø 40 mm.

Girder overlap on both sides minimum 16.3 cm for GT 24 and 15 cm for VT 20.

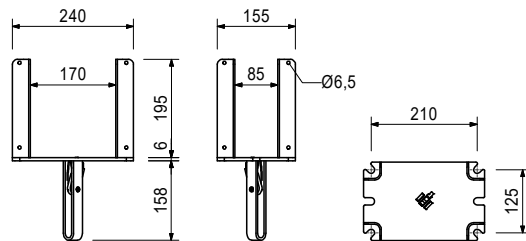
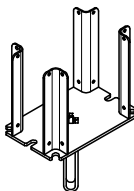

Accessory (not included)

027990 0.150 **Pin Ø14x107 mm ga**

018060 0.014 **Cotter Pin 4/1 ga**

MULTIPROP System

Art no. Weight [kg]

027296 6,220 **Tilting Base MP MKF**

For use on inclined assembly areas.
Can be pivoted by 3° in all directions.
With clamped quick-release fastener.

Notes

Permissible load capacity 60 kN.

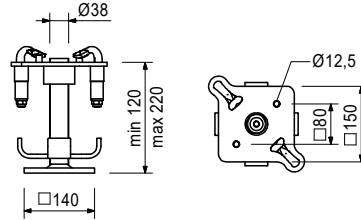
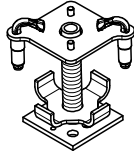

Art no. Weight [kg]

Scaff. Tube Couplers MP

027298 2,180 **Scaff. Tube Coupler MP MG-A/C**

027299 2,180 **Scaff. Tube Coupler MP MG-B/D**

For connecting scaffolding tubes \varnothing 48 mm to the MULTIPROP Slab Props.

Notes

Coupling cannot be rotated.

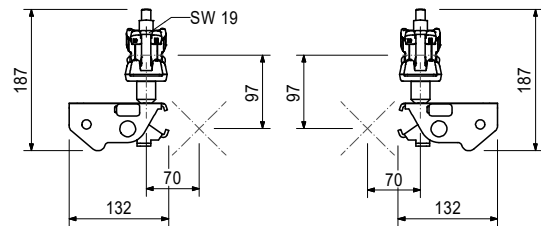
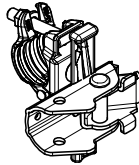

Art no. Weight [kg]

028000 9,190 **Universal Tripod \varnothing 57-120 mm**

Erection aid for slab props with \varnothing 57-120 mm and 120x120 mm.
Can also be used in combination with MULTIPROP Slab Props and all slab props with Base MP 50.

Notes

Only use as erection aid!

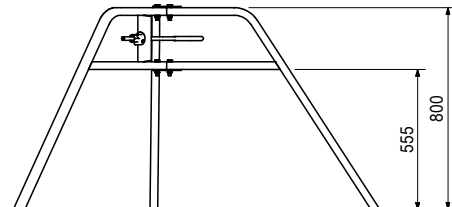
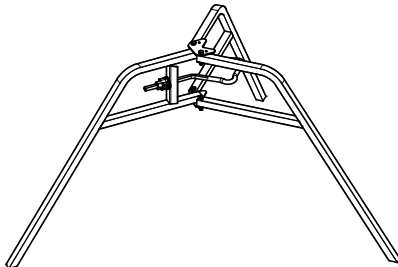

MULTIPROP System

Art no. Weight [kg]

027301 1,030 **Connector-2 MP MV**

For connecting 2 MULTIPROP Slab Props.

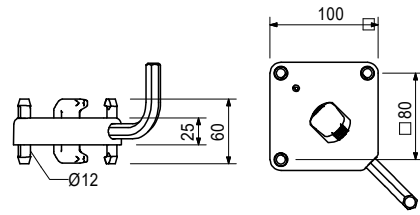
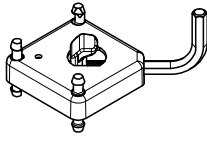

Art no. Weight [kg]

111142 0.082 **Screw with Nut MP**

For connecting 2 MULTIPROP Slab Props, for connecting Compression Brace Head MP/SRU and for mounting accessories on the Alu Beam MP MB 24.

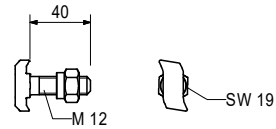

Art no. Weight [kg]

027302 2,100 **Strap MP U100-U140**

For fixing Steel Walers SRZ and SRU, Profile U100 to U140 on MULTIPROP Slab Props.

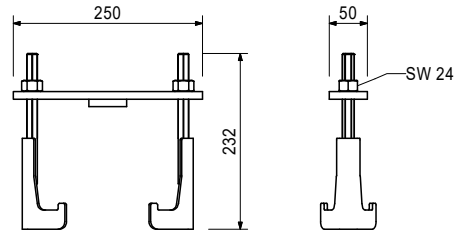
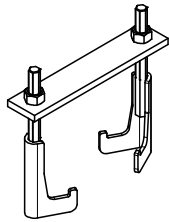

Art no. Weight [kg]

129565 1,680 **Brace Connector MP MR**

For connecting Push-Pull Props to the MP System.

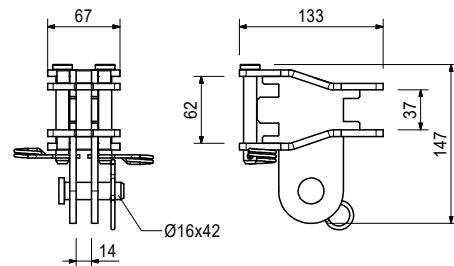
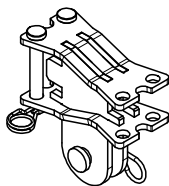

Consists of

- 027170 Pin Ø16x42 mm ga 1 pc
- 018060 Cotter Pin 4/1 ga 1 pc
- 129560 Collar Pin Ø12 mm coat 2 pc
- 127322 Cotter Pin 3. 2/2 coat 2 pc

MULTIPROP System

Art no. Weight [kg]

107161	3,050	Compression Brace Head MP/SRU
--------	-------	--------------------------------------

As connecting element between MULTIPROP Slab Props and Steel Waler SRU/SRZ.

Notes

Separate design information on request.
Permissible load-bearing capacity 70 kN.

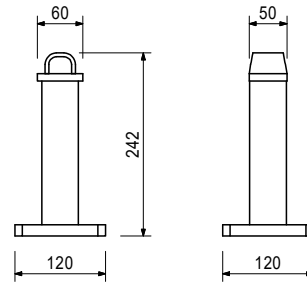
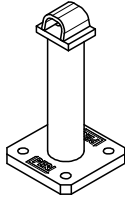

Accessory (not included)

111142	0.082	Screw with Nut MP
104031	0.462	Fitting Pin Ø21x120 mm
018060	0.014	Cotter Pin 4/1 ga

Art no. Weight [kg]

107160	3,950	Connector MP/SRU
--------	-------	-------------------------

As compensation element between the Prop Head MP/SRU and inclined positioned Steel Waler SRU.

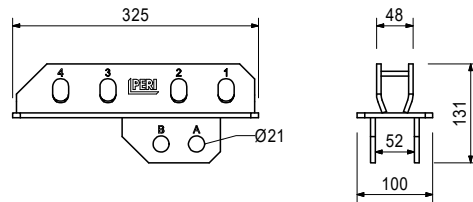
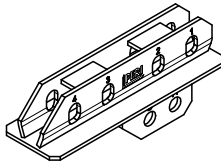

Accessory (not included)

104031	0.462	Fitting Pin Ø21x120 mm
018060	0.014	Cotter Pin 4/1 ga

Art no. Weight [kg]

104031	0.462	Fitting Pin Ø21x120 mm
--------	-------	-------------------------------

For different connections. High strength.

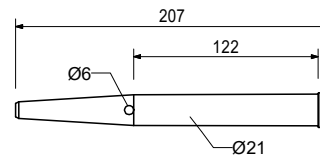
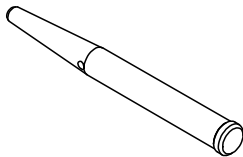

Accessory (not included)

018060	0.014	Cotter Pin 4/1 ga
--------	-------	--------------------------

MULTIPROP System

Art no.	Weight [kg]	
105400	0.330	Pin Ø20x140 mm ga

For different connections.

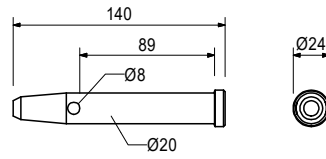
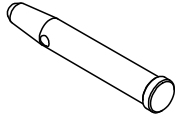

Accessory (not included)

018060	0.014	Cotter Pin 4/1 ga
--------	-------	--------------------------

Art no. Weight [kg]

018060	0.014	Cotter Pin 4/1 ga
--------	-------	--------------------------

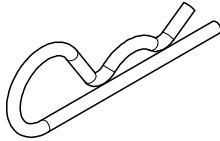

Art no. Weight [kg]

019200	162,000	Trolley with Winch
--------	---------	---------------------------

For moving towers and tables with MULTIPROP, PERI UP Flex, PERI UP Flex Plus, PERI UP Flex MDS K, PD 5 and PD 8 with appropriate support for the system.

Notes

Follow Instructions for Use!
Permissible load capacity 1.0 t.

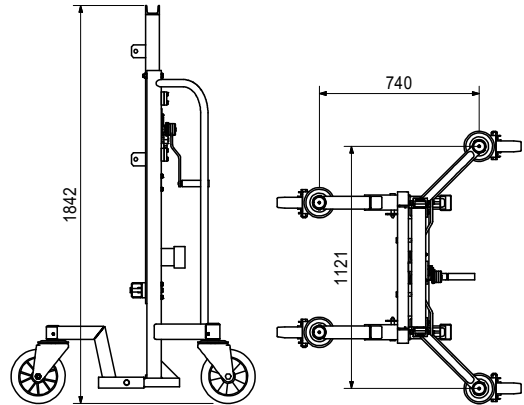
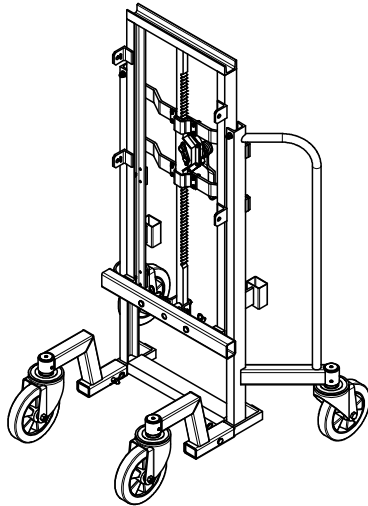

Accessory (not included)

118114	14,200	Connection MP Trolley
118115	11,000	Connection PD8 Trolley
130501	27,100	Connector PERI UP – Trolley
417954	21,200	Connection Rosette PLUS Trolley
418605	21,500	Connection Rosette – Trolley

MULTIPROP System

Art no. Weight [kg]

118114	14,200	Connection MP Trolley
--------	--------	------------------------------

For moving Towers MP with Trolley with Winch.

Notes

Consisting of support left and right (2 parts).

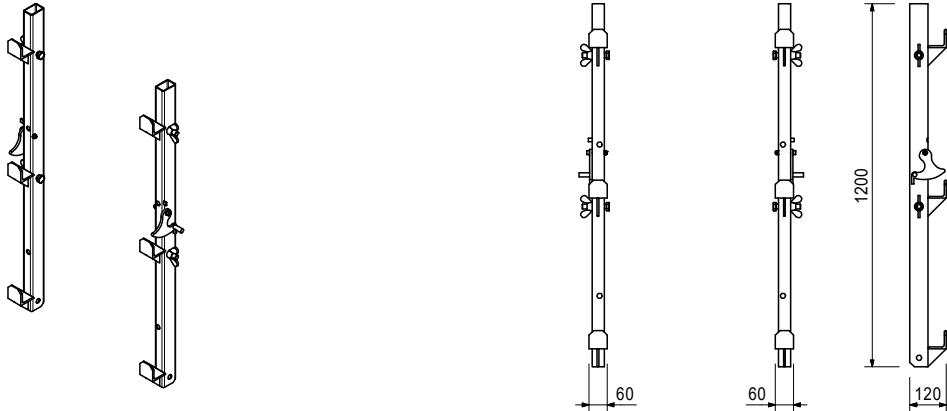

Art no.	Weight [kg]		L [mm]
Alu Beams MP MB 24			
079300	24,000	Alu Beam MP MB 24x300	2998
079360	28,800	Alu Beam MP MB 24x360	3598
079420	33,700	Alu Beam MP MB 24x420	4198
079480	38,500	Alu Beam MP MB 24x480	4798
079540	43,300	Alu Beam MP MB 24x540	5398
079600	48,100	Alu Beam MP MB 24x600	5998

Aluminium main beam for the MULTIPROP System.

Notes

- perm. Q = 50 kN
- perm. A = 80 kN
- perm. M = 15 kNm

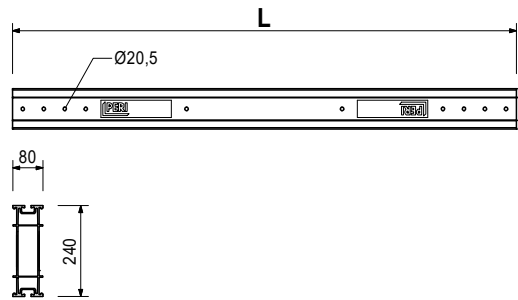
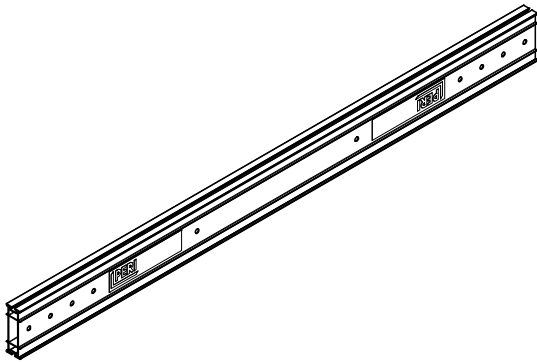

MULTIPROP System

Art no. Weight [kg]

107348	11,000	Coupler MP MB 24
--------	--------	-------------------------

For connecting the Alu Beam MP MB 24.

Notes

perm. Q = 23.5 kN
perm. M = 8.8 kNm

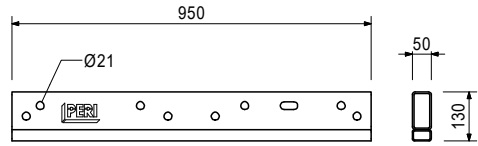
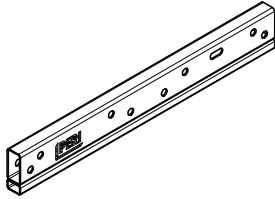

Accessory (not included)

105400	0.330	Pin Ø20x140 mm ga
018060	0.014	Cotter Pin 4/1 ga

Art no. Weight [kg]

108339	0.203	Quick Strap MP MB 24/GT 24
--------	-------	-----------------------------------

For fixing Formwork Girders GT 24 on the Alu Beam MP MB 24.

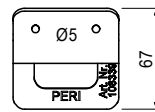
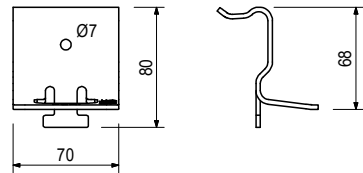
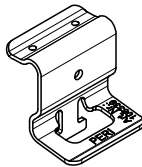

Accessory (not included)

018280	1.000	Double Head Nail 65 mm
--------	-------	-------------------------------

Art no. Weight [kg]

111000	0.815	Hook Strap MP MB 24/GT 24
--------	-------	----------------------------------

For fixing Formwork Girders GT 24 on the Alu Beam MP MB 24.

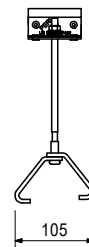
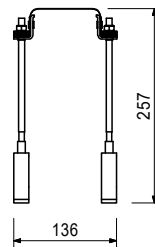
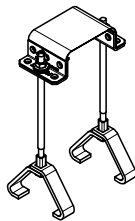

MULTIPROP System

Art no. Weight [kg]

107820 0.057 **Strap MP MB 24**

For fixing Alu Beam MP MB 24 to the MULTIPROP Prop or mounting the Formwork Girders GT 24 Girders on the Alu Beam MP MB 24.

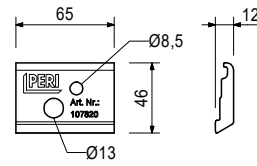

Accessory (not included)

111142 0.082 **Screw with Nut MP**

Art no. Weight [kg]

108213 2,590 **Brace Connector MP MB 24**

For connecting push-pull props or bracings to Aluminium Beam MP MB 24.

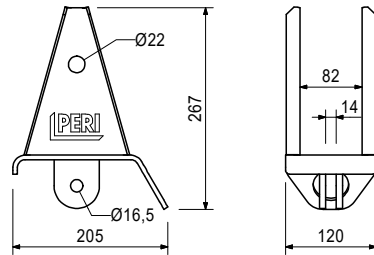
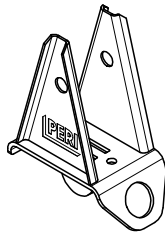

Accessory (not included)

104031 0.462 **Fitting Pin Ø21x120 mm**

018060 0.014 **Cotter Pin 4/1 ga**

Art no. Weight [kg]

104131 3,940 **Guardrail Holder SRU/SRZ**

For fitting a guardrail to the Steel Walers SRU or SRZ Profile U100 to U140.

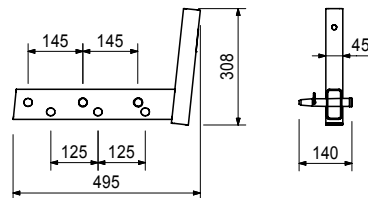
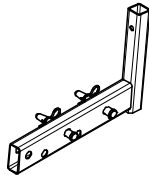

Accessory (not included)

116292 4,720 **Guardrail Post-2 HSGP**

061260 6,150 **Guardrail Post SGP**

Consists of

- 105400 Pin Ø20x140 mm ga 2 pc
- 018060 Cotter Pin 4/1 ga 2 pc

Art no. Weight [kg]

116292 4,720 **Guardrail Post-2 HSGP**

As guardrail for different systems.

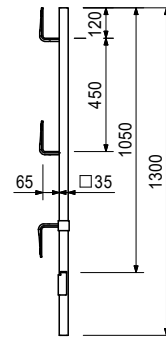



PERI Norge AS
Forskaling Stillas Engineering
Orhusveien 6
3070 Sande i Vestfold
Norge
Tel. +47 32 20 49 40
info@peri.no
www.peri.no