

VARIOKIT Engineering Construction Kit

System solutions for bridge, tunnel and civil engineering construction



Edition 04/2010

PERI GmbH
Formwork Scaffolding Engineering

P.O. Box 1264
89259 Weissenhorn
Germany
Tel. +49 (0)7309.950-0
Fax +49 (0)7309.951-0
info@peri.com
www.peri.com

Important Notes:

Without exception, all current safety regulations must be observed in those countries where our products are used.

The illustrations in this brochure are photographs of real site situations. Safety or formwork anchor details are therefore not to be taken as a definitive guide to the way the equipment is to be used.

Safety instructions and load specifications are to be strictly observed at all times. Separate structural calculations are required for any deviations from the standard design data.

The information contained herein is subject to technical changes in the interests of progress. Errors and typographical mistakes reserved.

Content

VARIOKIT Engineering Construction Kit

- 2 System solutions for bridge, tunnel and civil engineering construction
- 4 Engineering services and materials from one source
- 6 Rentable standard system components

VARIOKIT for tunnel construction

- 8 Cut-and-cover, semi-monolithic construction method
- 10 Cut-and-cover, separate casting method
- 12 Mining, semi-monolithic construction method
- 14 Mining, separate casting method

VARIOKIT for bridge construction

- 16 Parapet track
- 18 Parapet carriage
- 20 Parapet bracket
- 22 Steel composite carriage
- 24 Cantilever bracket
- 26 Launched traveller
- 28 Raised formwork units for civil engineering
- 30 Balanced cantilever traveller and arch cantilever carriage

VARIOKIT for civil engineering

- 32 Heavy shoring tower
- 34 Load-optimised truss construction
- 36 RCS Rail Climbing System
- 40 PERI International

VARIOKIT Engineering Construction Kit

System solutions for bridge, tunnel and civil engineering construction

PERI VARIOKIT, the engineering construction kit with rentable, standardised components.

With standardised, rentable PERI system components and construction-compliant connecting means, supporting structures can be cost-effectively erected and adapted geometrically to the respective structure.

High degree of versatility in the applications:

Bridges

- Mobile falsework
- Balanced cantilever traveller + arch cantilever carriage
- Steel composite carriage
- Cantilever bracket
- Parapets

Cantilevered parapet carriage
 Cantilevered parapet track
 Cantilevered parapet bracket

Tunnels

- **Cut-and-cover method**
 - Semi-monolithic
 - Separate casting method
- **Mined construction method**
 - Semi-monolithic
 - Separate casting method

Civil engineering

- General building construction
- Heavy-duty shoring
- Climbing technology

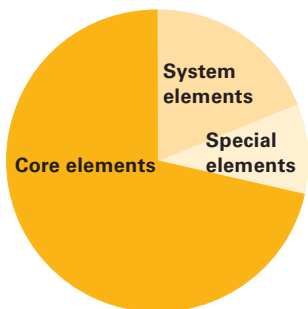

Steel Waler Universal SRU

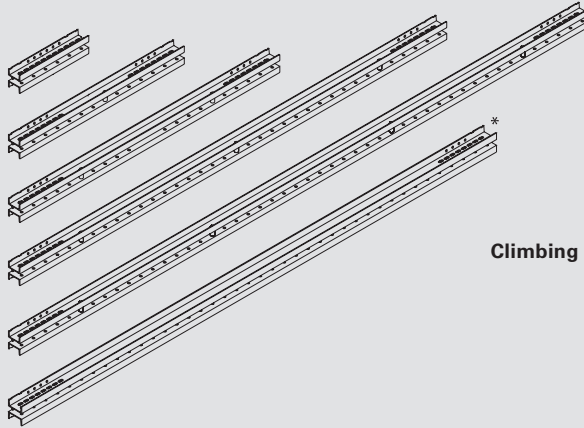

Climbing Rail RCS

Heavy-Duty Spindle SLS

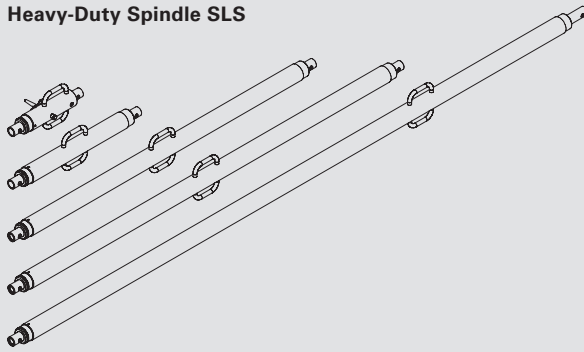

Only 3 core components required for a wide range of applications.

- **Flexible**
 Versatile core components with standard connections using bolts.
- **Load-optimised**
 Cost-effective use of materials through the static utilisation of the components with project-related adaptations.
- **Rentable**
 Economical solutions through the use of standard components taken from the PERI product range.

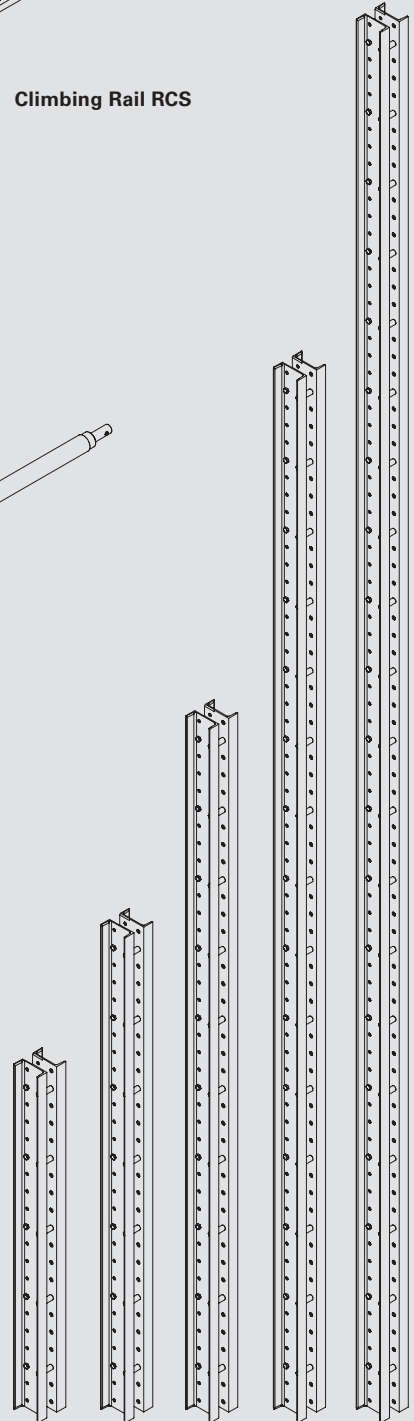

VARIOKIT for tunnel construction

Project-related designed tunnel formwork carriage consisting of standardised VARIOKIT components. Optionally available additional components such as drive mechanisms and hydraulic equipment for shuttering and striking increase the efficiency.



Project type
Cut-and-cover, separate casting method
Project
Bypass Tunnel, Tuttlingen, Germany

VARIOKIT for bridge construction

Flexible and cost-effective VARIOKIT formwork carriage solutions for bridge superstructures as well as construction of parapets, perfectly adapted to suit individual jobsite requirements.



Project type
Arch cantilever construction and mobile falsework
Project
Oparno Motorway Bridge, Czech Republic

VARIOKIT for civil engineering

The clearly defined permissible loads of the standardised components are suitable for all truss applications. Being able to rent the components along with the assembly advantages make VARIOKIT particularly cost-effective with short utilisation times.



Project type
General building construction
Project
Avala TV Tower, Belgrade, Serbia

VARIOKIT Engineering Construction Kit

Engineering services and materials from one source

Engineering services and materials from one source

The engineering services

PERI not only supplies the required materials. Experienced engineers develop customised formwork solutions. They combine load optimisation, flexibility and functionality for a very wide range of construction site requirements.

Included in the PERI comprehensive solution is all technical documentation such as static calculations, assembly drawings and instructions for use as well as assembly support and continuous support throughout the project.

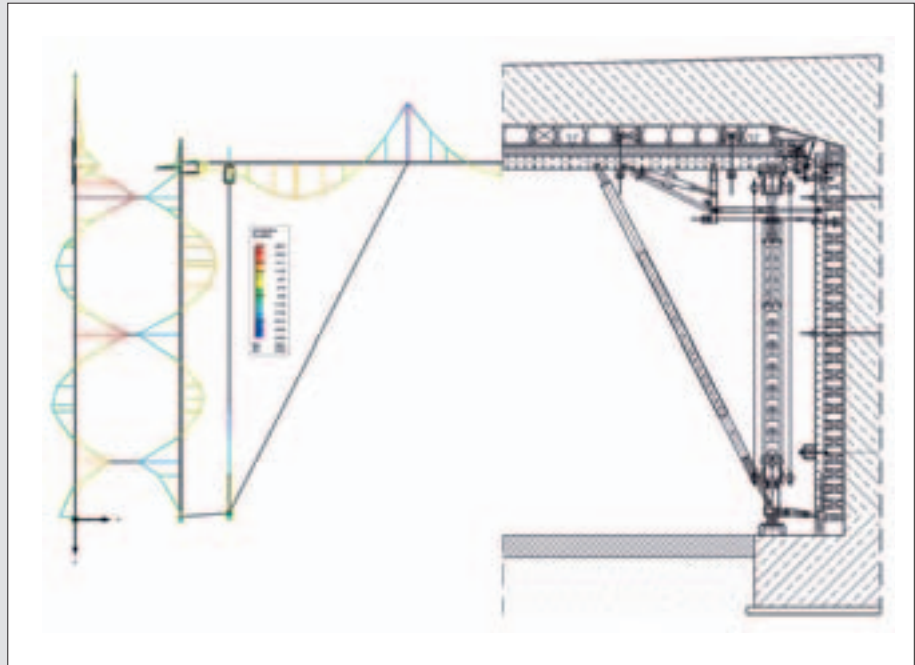

The planning of a tunnel with presentation of the moment curves in the system axes (left) as well as the cross-section (right).

The materials

VARIOKIT consists mainly of rentable standard components which remain unchanged but nevertheless are highly versatile in their use.

This results in the following benefits:

- small proportion of purchased parts.
- optimal adjustment to project requirements.
- as rentable system equipment at short notice from the rental park.



The three core components:

- Steel Waler SRU
- Climbing Rail RCS
- Heavy-Duty Spindle SLS

Each piece of formwork carries area loads (concrete pressure) via linear loads (waler loads) or individual loads (anchor or prop loads).

Classifying components in load groups allows load-optimized construction of the supporting formwork to take place over several steps.



Individual components and connections

Different components such as the Climbing Rail RCS and Heavy-Duty Spindle SLS, as well as the standard $\varnothing 21$ und $\varnothing 26$ bolt connections and their use, are type tested.

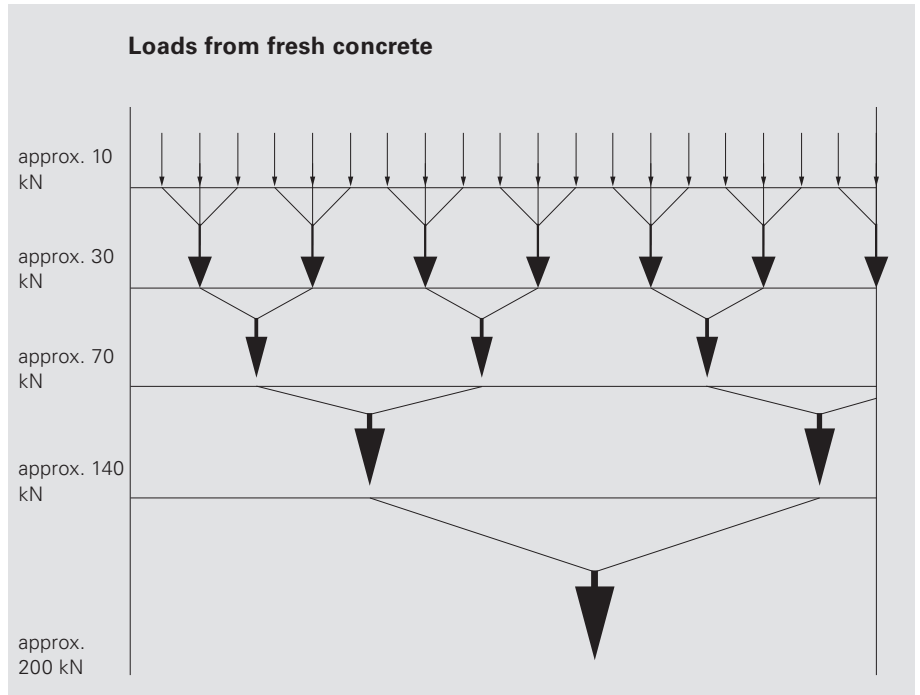

Perfect adjustment to the structure and load-optimized system solutions for cost-effective supporting formwork.

Other publications are available on tunnel and bridge construction.

PERI specialist literature

- Tunnel Formwork
- Bridge Formwork



VARIOKIT Engineering Construction Kit

Rentable standard system components

In cross-project situations, components are used again and again which are standardized.

Components which have a mutual function are put together in groups. For example, the assembly group featuring the Heavy Duty Roller, Concrete Pump Connector or components for lifting, lowering or moving.

Fundamental details such as the scaffold tube connector as side protection is taken into consideration just as much as technical working requirements (e.g. Concrete Pump Connector).

Also optimal additional components such as the drive mechanism, electrical or hydraulic components are part of the wide range of possibilities provided by the PERI VARIOKIT.



As an option, the tunnel formwork carriage can be equipped with the hydraulic lifting and lowering unit. In addition, the unit allows easy adjustment of the formwork to suit the particular gradient.



RCS climbing rail with hydraulic climbing device.



Simple and effective, the scaffold tube connector on the guardrail post for optimal working safety.



The PERI BPA concrete pump connector is compatible to the TRIO, MAXIMO and VARIO GT 24 wall formwork systems.

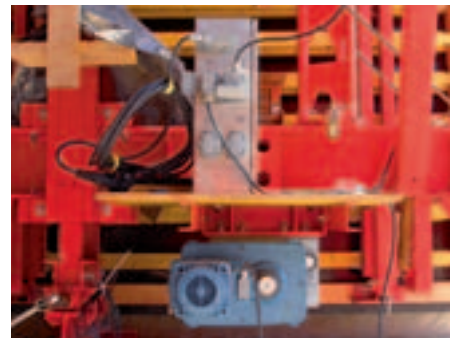

If required, the electric drive can be used for moving purposes. It can be retro-fitted on the wheel.

For the complete construction kit, there are only a few type connections with particular advantages:

- Very few different connecting parts, e.g. fitting pins and cotter pins.
- Standardized connection loads according to type of connection.
- Simple and easy on-site assembly.

With the RCS 97 climbing rail connector, RCS climbing rails can be extended without any loss of load-bearing capacity. In addition, SLS heavy-duty spindles can be attached.

SLS heavy-duty spindles are mounted to the RCS climbing rails by means of SLS/RCS spindle adapters.

The RCS scaffold tube adapter \varnothing 48 connects scaffold tubes \varnothing 48 with the load-carrying system.

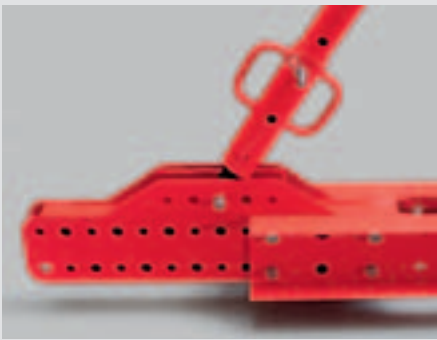

Climbing Rail Connector RCS 97
Item no. 111390



Spindle Adapter SLS/RCS
Item no. 110477



Scaffold Tube Adapter RCS \varnothing 48
Item no. 110084

For using the RCS climbing rail as waling for wall formwork, the GT 24 is mounted with the Hook Strap Uni HBU 24-26 U 200.

Frame structures and brackets are constructed with the Climbing Rail Angle Connector RCS. Connecting the SLS heavy-duty spindles or tie yoke is also easily carried out.

The RCS/SRU angle connector can be installed both as an articulated as well as rigid connection.



Hook Strap Uni HBU 24-26 U 200
Item no. 111806

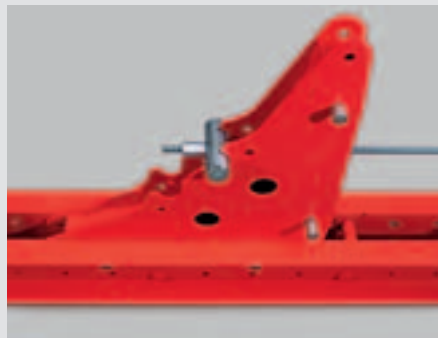

Climbing Rail Angle Connector RCS
Item no. 111382



Angle Connector RCS/SRU
Item no. 111283

VARIOKIT for tunnel construction

Cut-and-cover, semi-monolithic construction method

Tunnel formwork carriages are always project-related solutions. VARIOKIT provides an answer with standardized system components.

The advantages of the PERI VARIOKIT formwork carriage:

- Few anchors required in wall areas due to system walers up to UU 200.
- Simple modifications for different cross-sections.
- Optionally available hydraulic support for shuttering and striking as well as lifting and lowering.
- Self-propelled or mobile solutions for moving complete units.



All components can be optimally adapted:

- The HD 200 heavy-duty props allow continuous height adjustment and gridless assembly versions.
- The RCS slab beam can be flexibly adapted.
- the VARIOKIT diagonal strut is continuously usable from 4.0 to 9.0 m.



The diagonal strut is mounted on the slab beam with standard connections. The regular hole pattern in all system components provides many connecting possibilities.



The combination of proven systems such as VARIO GT 24 and HD 200 with new elements from RCS or the diagonal strut, results in a cost-effective formwork carriage.



The modular PERI VARIOKIT system for a wide range of practical solutions.

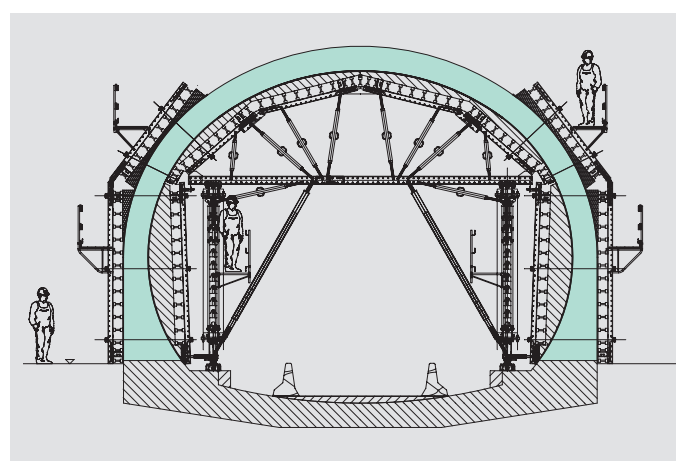

Circular cross-sections are also just as possible as separate individual formwork carriages for walls and slabs.

VARIOKIT for tunnel construction

Cut-and-cover, separate casting method

The separate casting method is the simplest variant for the construction of tunnels using the cut-and-cover modus operandi.

Here, the advantages of the VARIOKIT construction kit really come into their own. Through the possibility of being able to rent the system, a mobile transporting unit pays off also if only a few cycles are required.

Economical formwork solutions as well as tunnel cross-sections with variable dimensions are the standard applications of the separate casting method. All PERI wal and slab formwork systems can be used here. Mobile solutions are normally realised with VARIOKIT components.

■ Technical processing

Well-engineered technical planning allows cost-effective and efficient solutions which are precisely tailored to meet the requirements of the construction site. Regardless whether it is access portals for trucks or single-sided wall formwork with overhead support, such solutions are problem-free with VARIOKIT.

■ Wall formwork

The wall formwork is comprised of components such as waling, girders, accessories and anchoring systems which are available in the PERI VARIOKIT standard programme. At the same time, it offers considerable design possibilities and can also be constructed to handle high concrete pressures. This allows fast concreting with high form stability.

■ Minimum of anchors

The number of anchors can be clearly reduced through the use of the DW 20 and 26 tie systems which results in a substantial cost benefit.

■ Slab formwork

A project-related slab formwork carriage usually consists of one VARIOKIT load-carrying system and the formwork level. VARIO GT 24 girder wall formwork is frequently used for the formwork level.



A mobile formwork carriage was also designed for this centre wall of a double-tube motorway tunnel.



The formwork elements are suspended with chain hoists on the portal. This means shuttering and striking can be carried out without a crane.

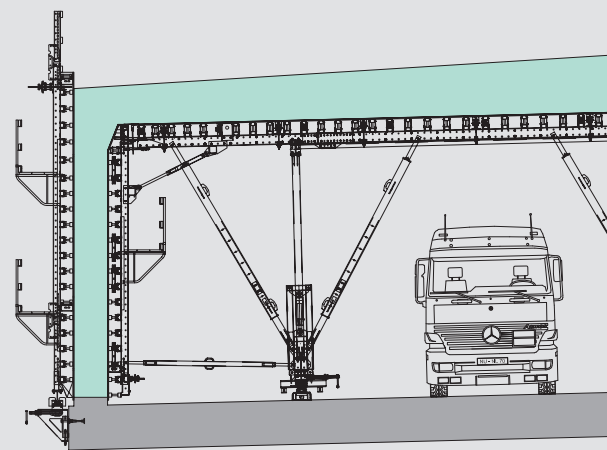



HD 200 heavy-duty props installed in the trailing slab formwork carriage accommodate the loads of this road tunnel constructed using the separate casting method.

Clearly visible are the 2 separate concreting cycles, the wall on the left and the slab on the right. Both sets of formworks are designed as mobile units.

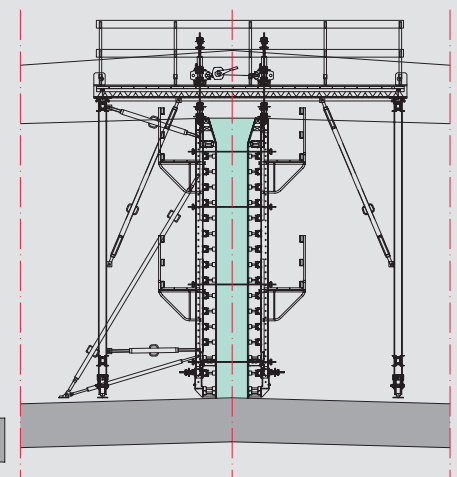
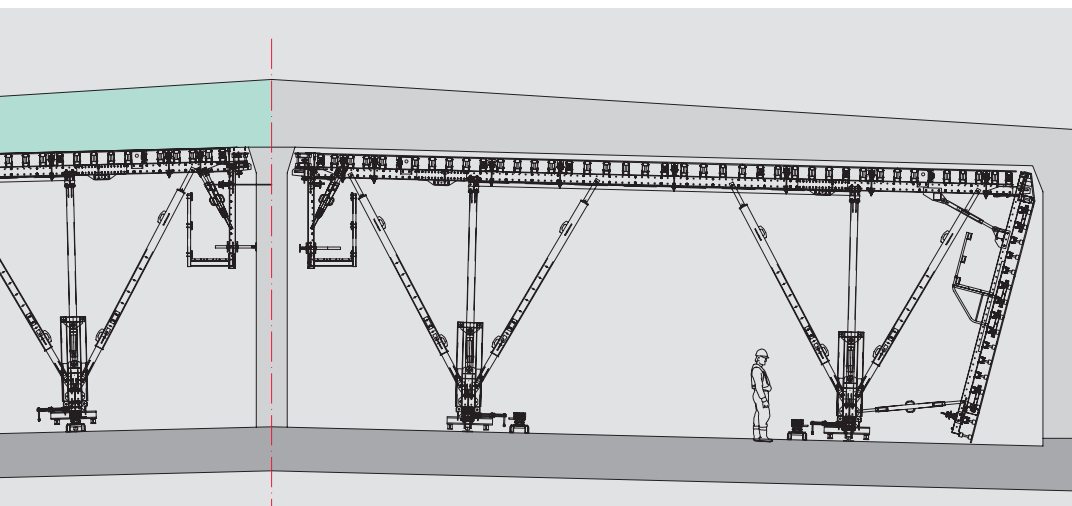
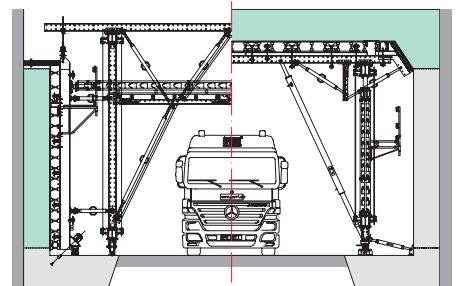

VARIOKIT for tunnel construction

Mining, semi-monolithic construction method



As a general rule, a formwork carriage for mining tunnels must fulfil very high requirements regarding wet concrete pressure and dimensional accuracy.

With shorter tunnels (up to approx. 40 sections) as well as for widened areas etc., formwork carriages which have been assembled using rentable system components are used.

It is particularly with the use of these standard components that the advantages are clearly demonstrated through the short operating times or very few sections. Rentable components also for high loads, hydraulic control element and electric drive units, make the standard carriage very easy to use. In addition, the time required for assembly and dismantling as well as moving are about the same with both versions.

Technically demanding solutions and easy handling are not mutually exclusive. As a result, constructions can be realised with VARIOKIT which optimally fulfil the boundary conditions of the construction site.



For mining tunnels, access portals are an important prerequisite for the use.



The PERI UP scaffold system offers all possibilities - from a simple stair tower through to a complete sealing carriage.

■ **High permissible concrete pressure**

A mining tunnel formwork carriage safely accommodate wet concrete pressures of up to 120 kN/m².

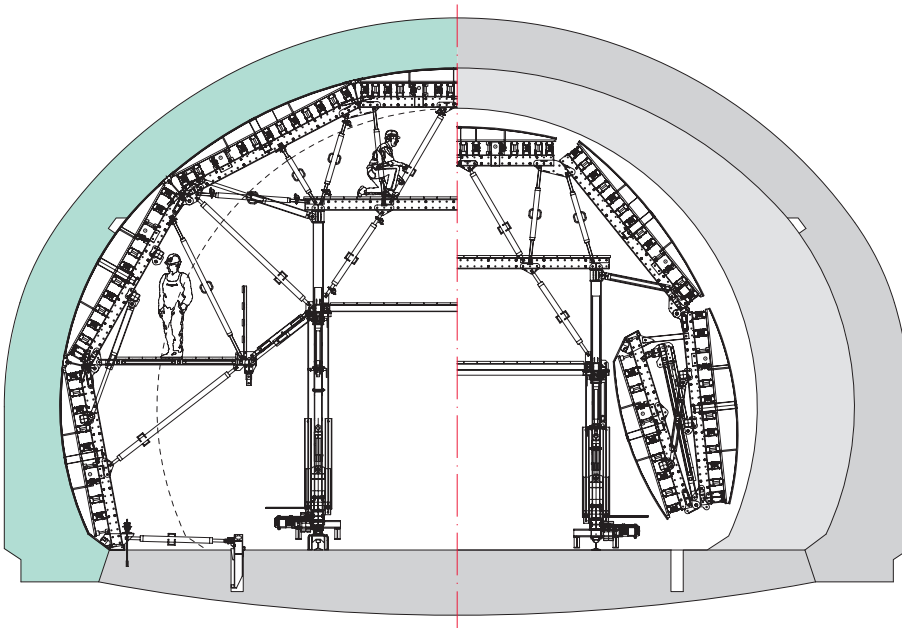

This tunnel formwork carriage can fold itself to suit the passage dimension of the standard cross-section, move laterally along the correct axis (with the help of the lifting and lowering unit) and subsequently move forward. After this, it is moved sideways again and brought into the concreting position.

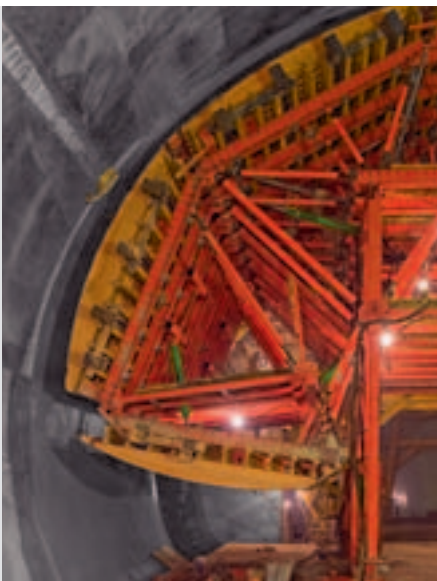

Optional VARIOKIT accessories such as hydraulic winches, electric drive units, lifting and lowering units and hydraulic cylinders for operating the wall and slab formwork elements are available in the VARIOKIT construction kit and, if necessary, are planned according to project requirements.



Optional VARIOKIT accessories such as hydraulic winches, electric drive units, lifting and lowering units and hydraulic cylinders for operating the wall and slab formwork elements are available in the VARIOKIT construction kit and, if necessary, are planned according to project requirements.



Optional VARIOKIT accessories such as hydraulic winches, electric drive units, lifting and lowering units and hydraulic cylinders for operating the wall and slab formwork elements are available in the VARIOKIT construction kit and, if necessary, are planned according to project requirements.

VARIOKIT for tunnel construction

Mining, separate casting method

The extremely high loads carried by a tunnel formwork carriage during mining operations present a special challenge for PERI VARIOKIT.

In order to effectively manage the forces and, at the same time, provide construction site traffic an access portal, the VARIOKIT with anchoring components combination is supplemented with the SB brace frame system. For smaller tunnel lengths (< 40 cycles) with short section lengths (< 20 m) and tight construction schedules (< 12 months), solutions using rentable parts are considerably more cost-effective than complete project solutions with special steel components.

For tunnels constructed using mining techniques, the formwork is always designed whilst considering ancillary conditions which are, in part, not compatible:

- Large loads resulting from the fresh concrete pressure and dead weight.
- Low individual weights due to tight space conditions during assembly and operations.
- Minimum of material costs from high proportion of rental parts and small quantities.
- Few operating elements and optimally adapted to suit construction progress.
- Simple operation of large units.



The first section with the bottom slab and starter has already been concreted.



Best concrete results from the 2nd cycle (wall area) form the exit for the arched formwork carriage.



The experience gained from brace frame anchoring can also be used in the 2nd cycle.



System components for the carriage and the movable formwork suspension allow flexible utilization.

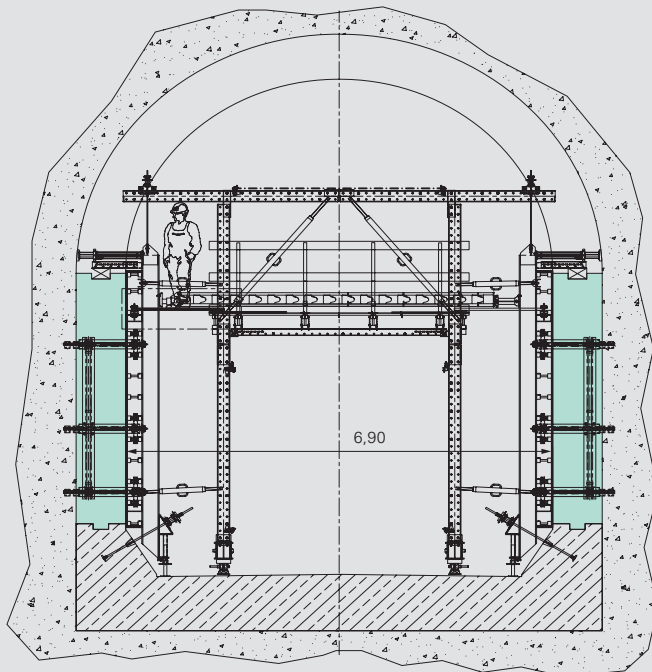

The transportation carriage from the RCS system moves the formwork and support unit to the next cycle.

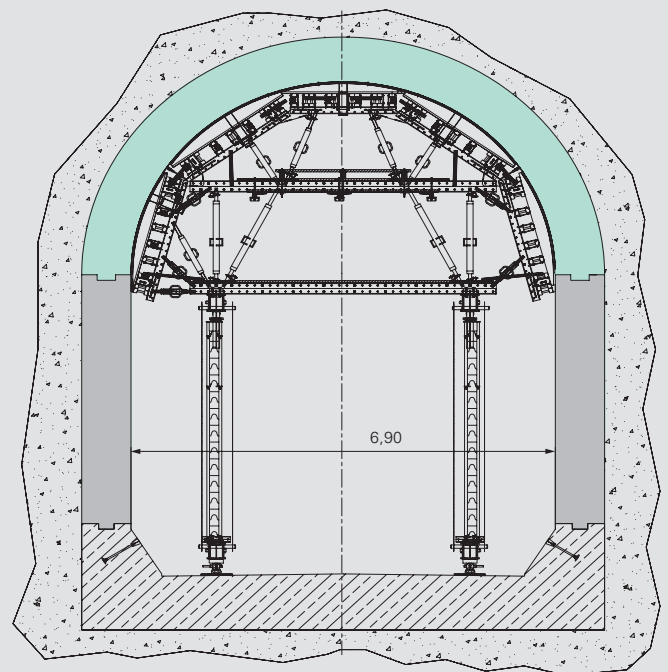

The formwork carriage for the 3rd cycle (arched section) also corresponds to project requirements.

Through the possibility of installing only those parts in the component levels which are required in each case for transferring in part large forces, load optimization can be achieved.

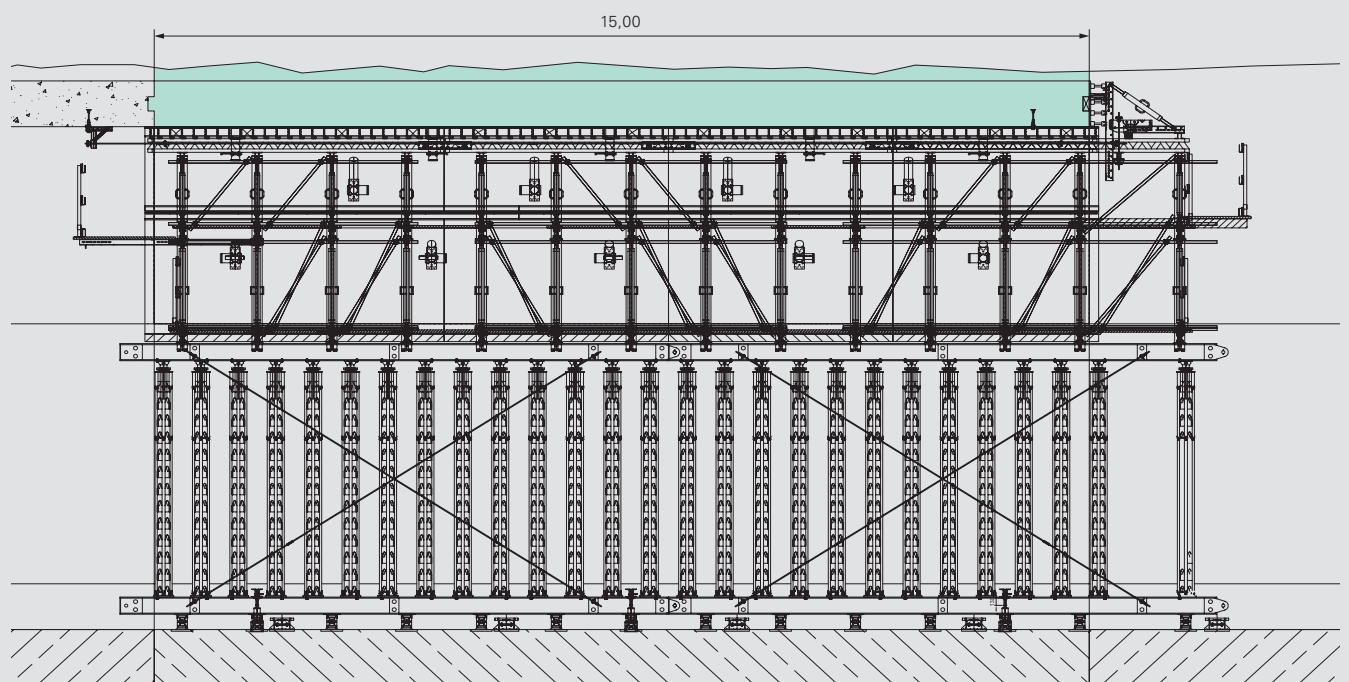

VARIOKIT for bridge construction

Parapet track



The VARIOKIT parapet track is used for the construction and refurbishment of parapets at the edge of bridges and between the superstructures.

Their main components are:

- multifunctional rails
- roller unit
- anchoring

The interaction of these 3 parts leads to the fact that load cases such as moving, vertical and horizontal concrete loads and the dead weight are likewise transferred like loads from working operations and wind without any additional fixings to the superstructure. Through the anchoring to the underside of the bridge and the low structural height, the parapet to be formed is freely accessible. Working operations can be carried out on and under the bridge during moving traffic.

Through the flexible adaptation of the parapet track, outer and middle parapets can be realised without any problems.



Free access from the top side of the bridge without disruptions through the overhead load-carrying construction.



Optimal and flexible adjustment to the bridge geometry for the construction of the middle parapet.

GS-certified safety for the GKB work cage.



The geometry of the suspension anchor allows fast lateral and perpendicular self-adjustments of the roller unit.



The track units roll self-centering over the roller units and rails along the bridge gradient.



Assembly on the bridge superstructure takes place with the GKB work cage while the assembly fitter is secured by means of personal protective equipment against falling.

Striking procedure

The parapet track is moved as a complete unit. The rollers to be freed up are dismantled from the finishing platform and re-mounted in the moving direction at the front from the leading platform.

In accordance with the size of the parapet, anchor spacings of 100, 125 and 150 cm can be

realised by combining the 100 and 150 cm rail lengths. This leads to optimal utilisation of the formwork carriage and a reduction in the number of anchor points.

Safe access possibilities to the platforms are provided via the leading and finishing platforms.

Cross-section

Safety during concreting and operations is guaranteed at all times through separate concreting and working platforms.

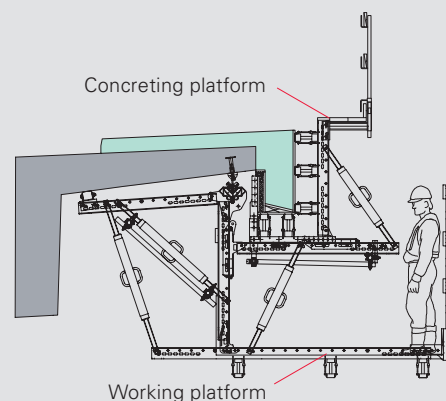
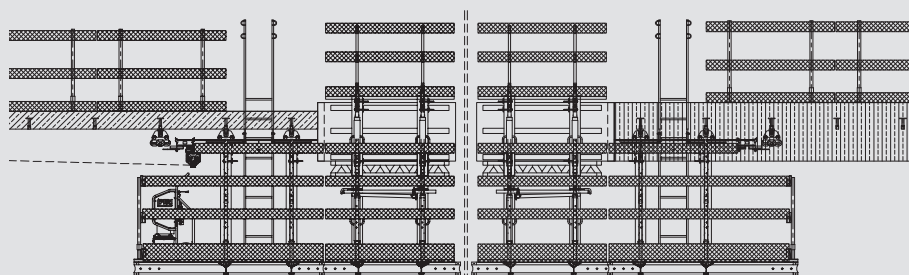

VARIOKIT for bridge construction

Parapet carriage



For meeting the requirements of modern bridge construction, the PERI parapet carriage provides an economical and efficient solution.

Thanks to the VARIOKIT construction kit, it can be optimally adapted to the construction site requirements.

The advantages of the VARIOKIT parapet carriage:

- less deformations under load.
- variable spacings between the individual sections.

Moving the formwork carriage is carried out cost-effectively and according to project requirements by means of steel profiles. As a rule, no anchorage is required for the structure and the horizontal force is transferred with friction.

The few different components actually required can be clearly seen here:

- Steel Waler SRU
- Climbing Rails RCS
- Heavy-Duty Spindles SLS
- Accessories such as scaffold tubes and couplers

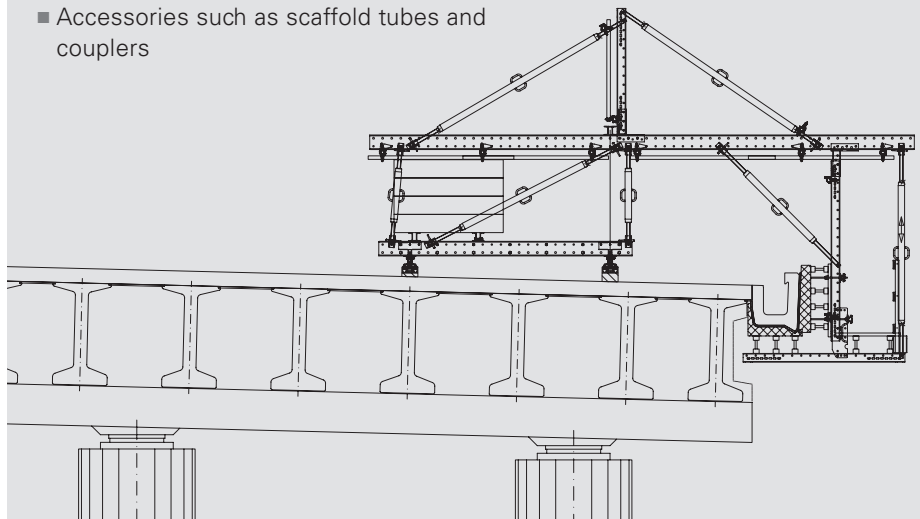

All required adjustment work takes place from the working platform. At the same time, there is an option of using a second working platform.

The different versions can be adapted to the structure and allow:

- keeping the clearance profile free
- construction of special geometries
- working areas for inspection work on the structure's web.



Short cantilever overhangs, interruptions through transversal steel girders in the area of the cantilever and limited clearance profiles are the decision criteria for the PERI VARIOKIT parapet carriage.

Projects with special requirements such as this bridge show the high degree of variability of the PERI VARIOKIT parapet carriage. Here, 5.00 m had to be spanned without support on the pedestrian and cycle lanes.



VARIOKIT for bridge construction

Parapet bracket



The lightweight PERI parapet bracket can be installed by hand and rounds off the range of parapet solutions. For the new construction of short bridge superstructures as well as re-rurfishment, the parapet bracket is a rational and economical solution.

Special attention during the development was focused on the weight reduction of individual components. The heaviest part weighs only 18 kg and thus allows assembly by hand.

Apart from the weight reduction, particular importance was placed on completely separating the formwork support from the platform. Due to this separation, closed through to watertight enclosures can be realised.

Adjusting to the parapet geometry and operations safely takes place from the closed platform.

For the construction crew this means:

After the initial assembly, access by means of an elevating work platform or scaffolding is not necessary.



Due to separating the formwork support and platform, re-installation of the platform after the demolition work for concreting is not required. The formwork support is simply positioned on the platform.

The VGK parapet bracket platform unit for the demolition of a parapet.

The mounting shoe of the bracket allows 2 versions of anchoring:

- New bridge construction with the high load-bearing and proven PERI Anchor Sleeve M24
- Bridge refurbishment with various commercially available bonded tie systems together with official approval.

Easy and fast assembly by hand.



The bracket suspension head with anchoring details.

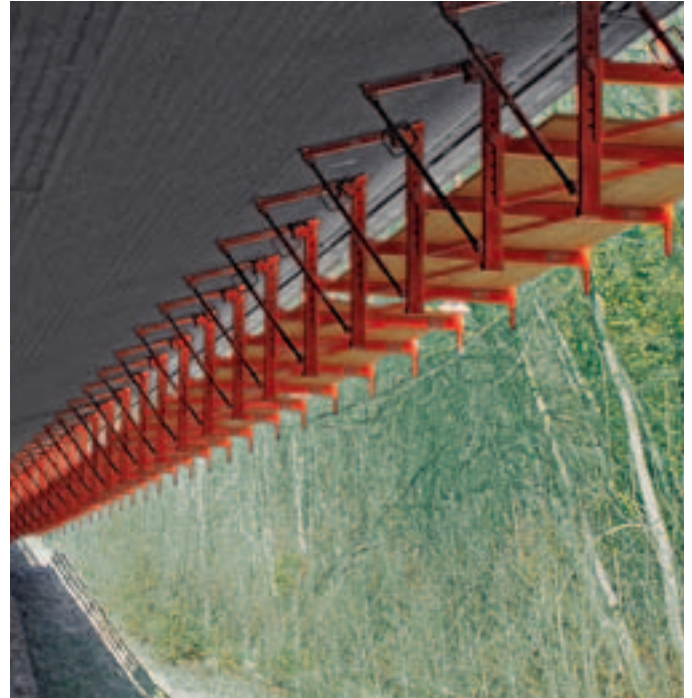

The VGK parapet bracket has been designed for horizontal and vertical use. The consoles can be mounted to the underside of the cantilever as well as the abutment walls by simply re-bolting.

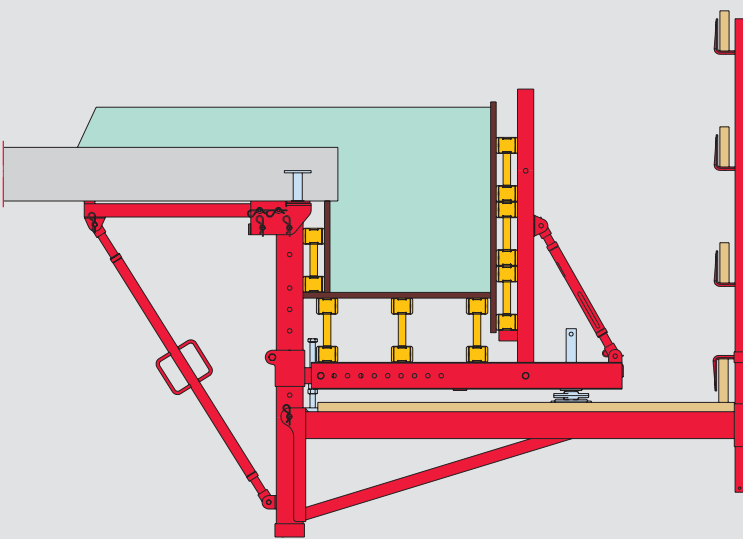

Horizontal use
in the area of the cantilever.

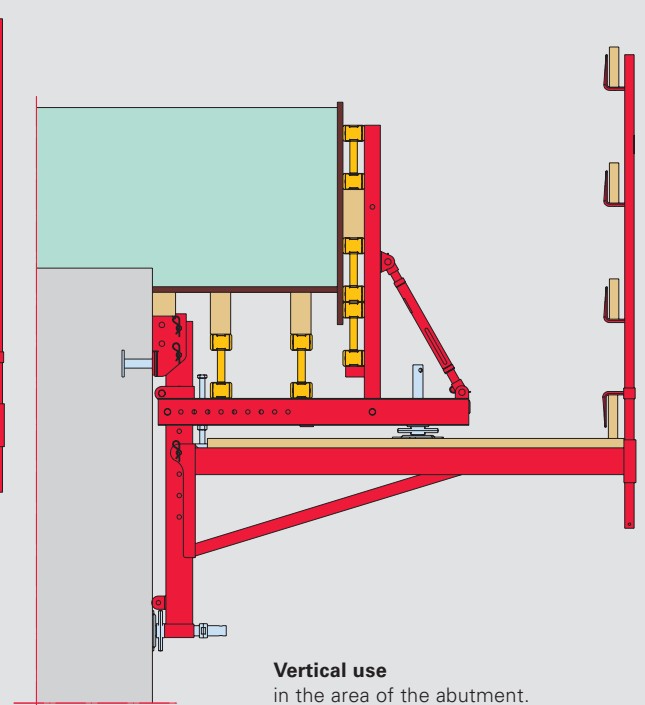

Vertical use
in the area of the abutment.

VARIOKIT for bridge construction

Steel composite carriage

The VARIOKIT formwork carriage for steel composite bridges fulfils all the project requirements.

The advantages of the PERI VARIOKIT formwork carriage:

- high rigidity in both the longitudinal and transverse directions of the carriage.
- variable and flexible arrangement of the support points (carriage supporting point) on the bridge longitudinal beam.
- with the unique steerable carriage supporting shoe, forming of bridge radii is possible without any great effort.
- through the rigid longitudinal truss, cross frames are not restricted by any increments and can always be completely utilized.



The extremely rigid main beam truss ensures optimal load distribution and protects the bridge girders against excess point loads.

Striking can take place either from the concreting level or the finishing platform.



The steerable carriage supporting shoe is mounted to the carriage supporting point.



The internal formwork is selected according to the geometry of the structure.

In so doing, a difference is made between:

- movable slab formwork element on roller brackets
- MULTIFLEX formwork
- panel formwork

Through the enormously high number of combination possibilities for the system components, modifications can also be carried out at any time for other bridge cross-sections.

The external formwork carriage is mounted on the main beams of the bridge. The three main component groups can be clearly seen:

- longitudinal truss
- cross beam
- formwork unit with adjustment device

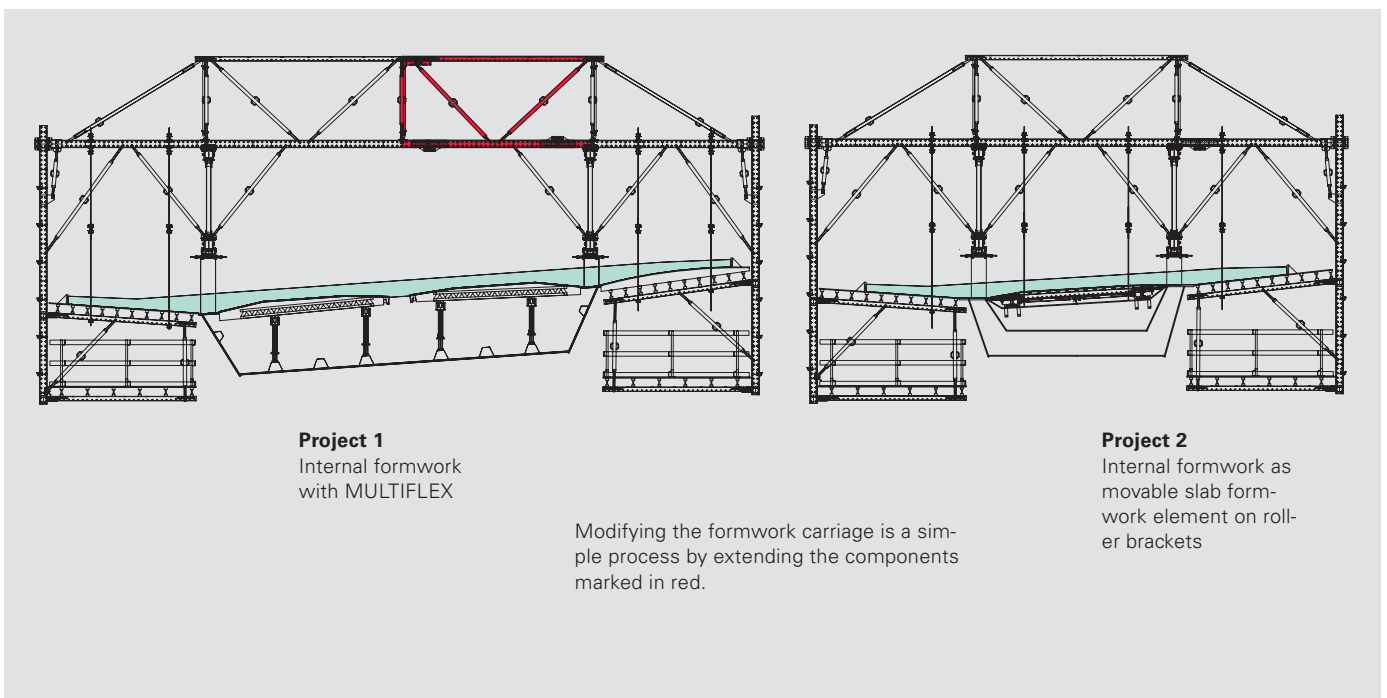

Project 1
Internal formwork with MULTIFLEX

Project 2
Internal formwork as movable slab formwork element on roller brackets

Modifying the formwork carriage is a simple process by extending the components marked in red.

VARIOKIT for bridge construction

Cantilever bracket

The PERI VARIOKIT cantilever bracket is the construction kit solution for the realisation of bridge cantilevers using the steel composite and semi-prefabricated concrete component construction methods.

Both for short crossings of railway lines, motorways or side streets as well as and with large formwork quantities, the cantilever bracket provides cost-effective and rational solutions.

The necessity for a mobile solution does not apply with these projects as the superstructure is usually constructed in one casting segment.

Decisive advantages:

- fast assembly
- low dead weight
- suspension with DW 15 system

Bridge near St. Paul, Austria:
railway crossing.



Areas of application for the VARIOKIT cantilever bracket are:

■ Steel composite construction method

Combination of steel girders in the tensile areas and in-situ concrete slabs in the compression areas of the bridge cross-section.

■ Semi-prefabricated concrete component construction method

Tensile area of the prefabricated concrete girders and compression slabs from the in-situ concrete slabs.



Steel composite construction method
Chinchage Brücke, Canada
Steel girders with in-situ concrete slabs.



Semi-prefabricated concrete component construction method
Golden Ears Bridge, Canada
Prefabricated concrete girders with in-situ concrete slabs.



Bracing the bracket units with commercially available scaffold tubes Ø 48 mm.

The bracket units with side protection mounted on the steel girders serve, at the same time, as guardrails.

For anchoring, the DW 15 tie system comes in two versions.

Fixing to the steel girders is carried out by means of the weldable and screwable VARIOKIT anchor plate.

■ **Operable from the top side of the bridge**

The assembly and dismantling of the brackets takes place from the top side of the bridge via re-usable conical pipe nuts.

Advantages:

- No elevating work platform or ground-supported erection scaffolding is necessary.

■ **Operable from the underside of the bridge**

The bracket is fixed from below via the Tie Yoke Head SRU.

Advantages:

- no penetration of the superstructure.
- no interruptions points in the concreting work.



Support spindles for optimal adjustment to the bridge cross-section with an adjustment range of +/- 10 cm.



Anchor plate with pipe nut and DW 15 tie rod, can be operated from the top side of the bridge.



Tie Yoke Head SRU with DW 15 tie rod, can be operated from the underside of the bridge.

VARIOKIT for bridge construction

Launched traveller

The PERI VARIOKIT solution for the building method with underslung and overhead launched travellers.

In the process, the solution overhead launched traveller has a main beam on which the crosswise arranged trusses are positioned which carry the concreting loads of the cantilever. With suspension tie rods on the outer frame, all adjusting possibilities regarding inclination and position are possible.

■ Hydraulic operations

For some VARIOKIT projects, there is the option of being able to operate the formwork components with a mobile hydraulic system which is also available for use with the above-positioned launched traveller. Thus, only 4 hydraulic lifting cylinders are required regardless of the number of raised formwork units.



■ Assembly versions

The construction for both launched traveller versions - positioned overhead and underslung - is a modular design. Load-optimised width of influence on the two cross-frames form the basis of each launched traveller. The total number of cross-frames is, in each case, a multiple of the pairs of frames.



The transfer of the bearing loads into the pier is a very important area. Adaptable to the structural geometry and with system safety accessories, PERI UP provides an optimal solution here.



Assembly of the sub-assemblies in a position behind the abutment is the rule regarding initial assembly. At the same time, passing the abutment wall is a factor that must be taken into consideration.



Moving past the piers is possible without any problems after the working platform and slab formwork have been hydraulically folded in.



The underslung launched traveller can also be supplemented with system formwork thus ensuring cost-effective use. For moving, the traveller and formwork are firstly pushed sideways, then moved forward in a longitudinal direction and subsequently realigned.

VARIOKIT for bridge construction

Raised formwork units for civil engineering



PERI VARIOKIT raised formwork units provide flexible and economical solutions for a very wide range of requirements in modern civil engineering projects.

Due to their high flexibility, the units can be mounted on different load-bearing systems. Thus, the same raised formwork units are used on launched travellers, incremental launching equipment as well as light to heavy load-bearing scaffold.

Adapting to the wide range of bridge geometries take place continuously thanks to the VARIOKIT engineering construction kit.



Raised formwork units on the launching beam with large spans.

Raised formwork units on PERI UP Rosett supporting scaffold.



Frame construction formwork for incremental launching equipment. The raised formwork units remain firmly positioned on one side of the abutment and serve as formwork for the cyclic construction of the superstructure.

Time-saving and cost-efficient construction site assembly can be realized due to standardized connecting components such as the UK 70 coupling and bolt connections.

The formwork can be adapted at any time to structural changes by means of SLS spindles. Through this, VARIOKIT frame construction formwork provides a very flexible and economical solution for all conventional load-bearing systems and a broad range of building geometries.



Main components of the raised formwork units:

- Steel Waler SRU 120
- SLS Spindles
- Coupling Components
- Bolts Ø 21 or 26 mm.



■ **Articulated connection**
For transferring normal and shear forces between two walers. This results in an fully adequate joint between the SRU steel walers.

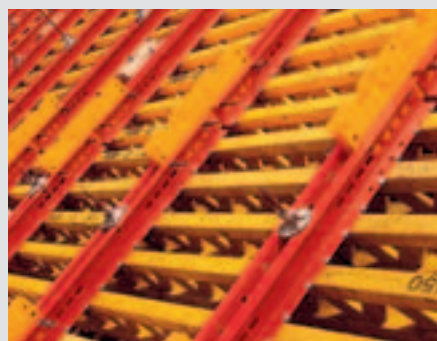

■ **Rigid connection**
All waler lengths can be combined without any loss of load-bearing capacity. The static values of the UK 70 coupling correspond to the profile of the SRU waler. The connection with the bolt Ø 21 x 120 is without any clearance.



■ **Connecting accessories**
In the widened areas, accessories can be bolted on. This means that spindles and diagonals etc. can be optimally positioned at the required points without having to take the couplings into consideration.

VARIOKIT for bridge construction

Balanced cantilever traveller and arch cantilever carriage

The PERI VARIOKIT solution for arch cantilever traveller is a combination of hollow box girders for carrying the loads and VARIOKIT standard components for the formation of formwork, working scaffold and platforms.

A self-launching procedure by means of integrated moving hydraulics, complete hydraulic adjustment and alignment lead to accurate concrete results. Millimetre deviations can be realized with arched spans of up to 140 m.

■ Time-consuming technical planning

Balanced cantilever equipment and formwork normally experience large changes in geometry and load which result from the varying heights of the superstructure towards the middle span. Here, detailed technical planning is indispensable. In addition, the constantly changing load conditions along with the resulting loads and deformations must be accurately calculated.

Using the very latest 3D formwork planning, PERI provides perfect implementation plans and detailed processing which make on-site forming cost-effective and efficient.



The transfer of very large loads through accurate static calculations for each climbing cycle are precisely implemented.



Changes to the external geometry of the web require variable constructions. VARIOKIT steel walers and spindles provide here a continuous and safe load-carrying system.



The PERI VARIOKIT balanced cantilever traveller consists of new main frames which allow compensation of the bridge longitudinal and lateral inclinations to be carried out without packing timber.

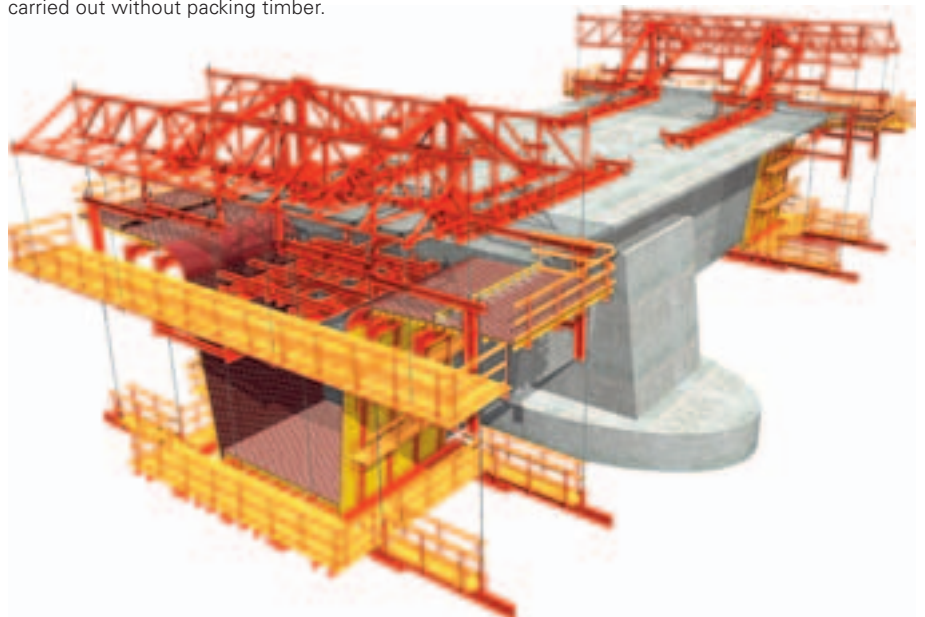

Furthermore, the inner sides of the bridge web also require filler areas in both the width and height. The VARIOKIT adjustment unit offers continuous adjusting possibilities.



Geometrically complicated details in the cantilever area can be flexibly formed with the VARIOKIT construction kit. Moving the formwork takes place by means of a lightweight chain hoist.



The transfer of the loads into the pier is a very important area. With the PERI UP scaffold system, flexible and safe access to this area is realised.

VARIOKIT for civil engineering

Heavy shoring tower

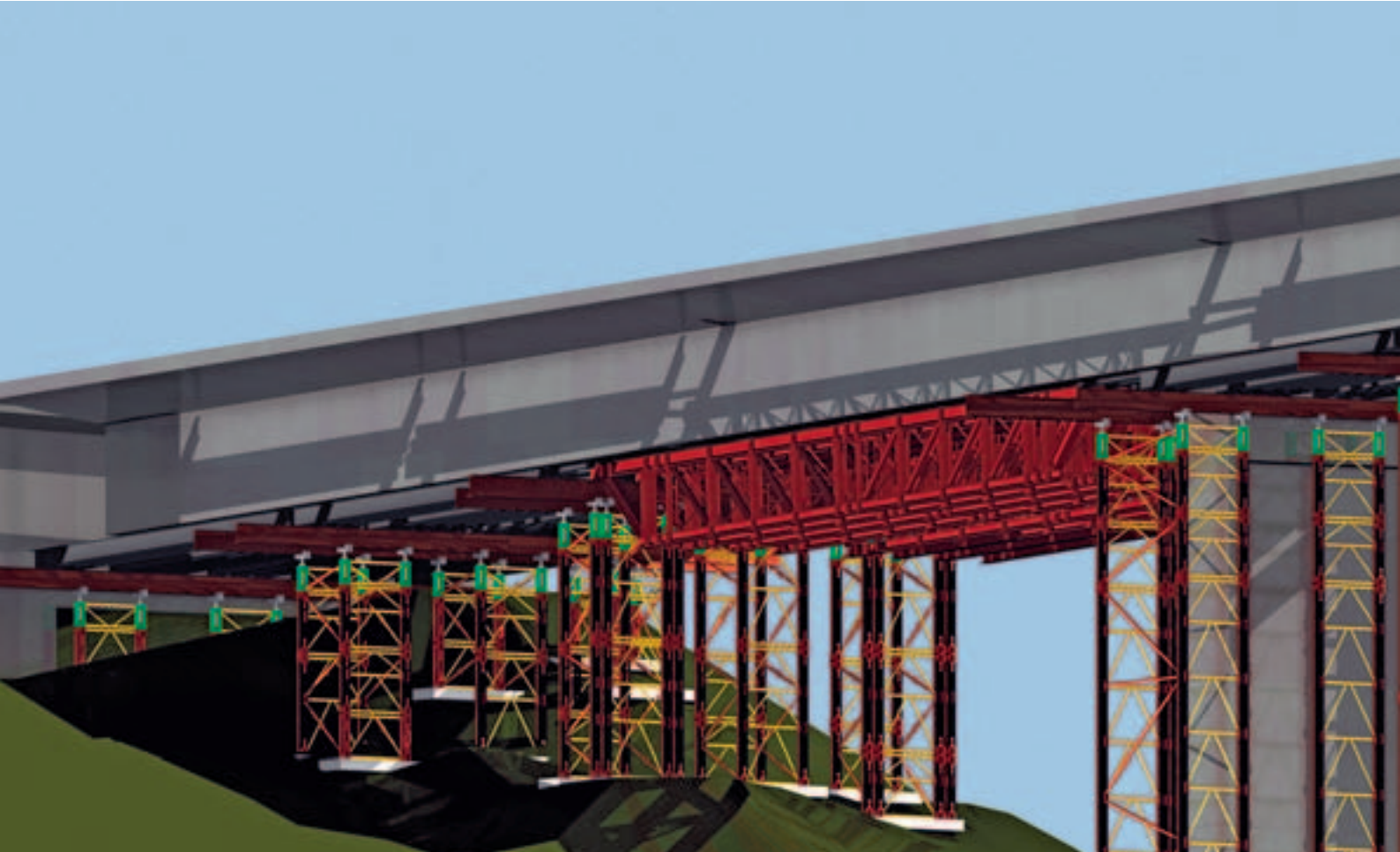

Heavy-duty shoring has been in use for many years in civil engineering. As the first manufacturer, PERI has redefined the application in the course of developing the VARIOKIT engineering construction kit.

With this, the disadvantages of the two conventional versions, load-bearing scaffold with steel profiles and special scaffold tower systems are avoided without additional application. Technical processing of heavy-duty shoring applications is very challenging. PERI makes this possible using the latest technology and flexibly used system parts. Here, the advantages of a large range of components come to the fore. Always having the correct length facilitates a cost-effective planning process. Heights to 40 m can be realised with VARIOKIT heavy shoring towers with a constant high load-bearing capacity up to max. 240 t.

4 assembly types are possible:

■ **Standard tower**

4 legs are assembled using the standard connection parts. This results in an axial dimension of 2 x 2 m.

■ **Tower with additional legs**

In very highly-loaded areas, additional legs can be placed with leg spacings of 37.5 cm. With this, the permissible load-bearing capacity is then doubled.

■ **Shoring tower frames**

Is a combination of legs to "frames" with load-dependent and geometrical necessary number of load-carrying components.

■ **Assembly as main beam frame**

Main beam frames, e.g. in front of abutment walls, can be assembled up to 10 m high as independent units only with head restraint.



A typical application example in bridge construction. VARIOKIT heavy shoring tower with heights from approx. 5.00 m up to 40.00 m.

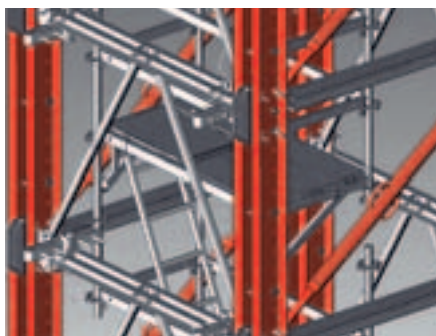

With PERI UP scaffold construction kit, all required stairs, access points and working platforms are quickly and safely erected.



The Leg Connector VST 48 is equipped with a centering aid. This allows easy and simple extensions.



With PERI bolts, the main connections of the individual components are carried out quickly, accurately and safely.



One component for extensions and base units - the Leg Base VST 48.

VARIOKIT for civil engineering

Load-optimised truss construction

With the help of VARIOKIT engineering construction kit, flexible, load-optimised and versatile trusses can be designed for load transfer.

Depending on the load, SRU Waler 120, RCS Rails U 200 or HDT Main Beam HEB 300 serve as the chord of the truss; in combination with SLS Spindles or rectangular struts as diagonal bracing, load-optimized solutions can be designed.

The extremely variable adjustment to the structural geometry takes place by means of a defined set of holes with 12.5 cm increments in the SRU and RCS rails.



Same system components for providing temporary support for the structure as well as for climbing scaffold application.



Adaptable trusses for transferring fresh concrete loads and as temporary structure support.



Simple and fast construction site assembly by means of bolted connections.

Main connecting means are bolts and fitting pins with Ø 21, 26 and 40 mm. Jobsite assembly is accelerated through standardized connecting components such as the UK 70 coupling or RCS 97 climbing rail connector.

Creation of horizontal assembly areas on inclined roof areas for falsework with VARIOKIT components.



The VARIOKIT system construction kit provides numerous combination possibilities with other PERI system components.



Rentable solution in bridge construction. Truss comprised of SRU steel walers with SLS spindles as diagonal bracing.

VARIOKIT for civil engineering

RCS Rail Climbing System

The RCS climbing system combines the advantages of different climbing systems in one modular system.

Depending on the requirements and use, the system can be climbed with the crane, or raised crane-independently by means of mobile, hydraulic climbing devices. The RCS modular construction system allows standard solutions to be easily adapted to project-specific requirements.

■ RCS Climbing Protection Panel

For completely enclosing floors under construction particularly those in high skeleton structures.

■ RCS Formwork Scaffolding

For rail-guided climbing of wall formwork.

The flexible anchoring of the RCS climbing system is the basis for numerous project successes all around the world, also for many extraordinary structures.

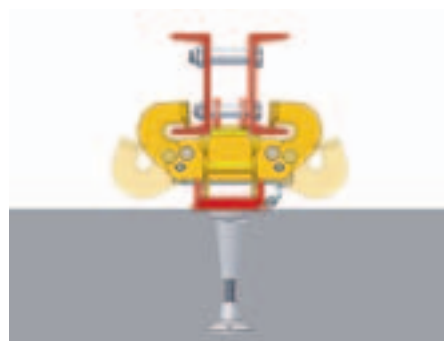

The RCS climbing shoe guides the climbing rail during the moving procedure. The integrated climbing pawl automatically engages the connection bolts of the climbing rail and secures the unit at a distance of 50 cm. Already during the first concreting cycle, the upper part of the formwork scaffolding is attached to the foldable runners of the climbing shoe.



Formwork for cores or facades of a high-rise building is climbed with PERI RCS just as safely and cost-effectively as for bridge piers.



Section of a RCS climbing protection panel

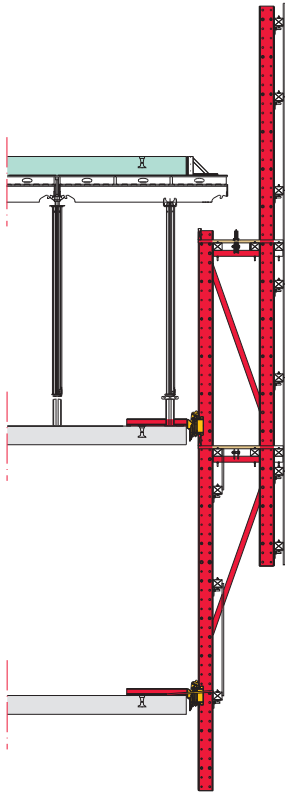

Section of RCS formwork scaffolding

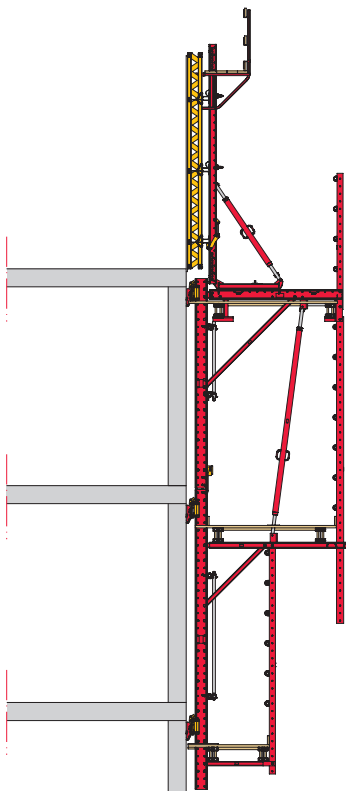

Both systems can also be climbed hydraulically and are thus crane-independent.

With the mobile self-climbing devices and hydraulic pumps, the cost of the self-climbing technology is reduced as well as ensuring cost-effective implementation for structures with lower heights.

Hydraulic pumps and cylinders are quickly operational and easy to transport.

With the climbing rail, the scaffold unit is always connected to the building by means of the climbing shoe for the entire climbing procedure. Moreover, it is impossible for the RCS climbing unit to "drift" during strong winds. This means that climbing can take place safely and quickly at any time.

The hydraulic cylinder, with 5 t lifting capacity, can be easily positioned on the climbing shoe and rail.

Advantages:

- The climbing rail is not climbed in advance but, instead, is part of the load-bearing system.
- Wall openings are easily bridged by the climbing rail.
- The mobile self-climbing equipment can be retrofitted at any time.

Climbing units are raised with a lifting speed of 1 m/min.

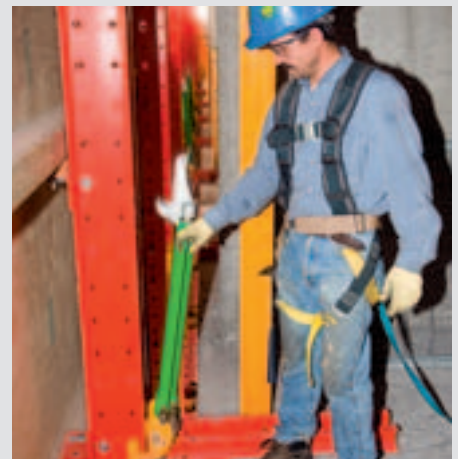



01 PERI GmbH
 Rudolf-Diesel-Strasse
 89264 Weissenhorn
 info@peri.com
 www.peri.com



02 France
 PERI S.A.S.
 77109 Meaux Cedex
 peri.sas@peri.fr
 www.peri.fr

03 Switzerland
 PERI AG
 8472 Ohringen
 info@peri.ch
 www.peri.ch

04 Spain
 PERI S.A.
 28110 Algete - Madrid
 info@peri.es
 www.peri.es

05 Belgium/Luxembourg
 N.V. PERI S.A.
 1840 Londerzeel
 info@peri.be
 www.peri.be

06 Netherlands
 PERI B.V.
 5480 AH-Schijndel
 info@peri.nl
 www.peri.nl

07 USA
 PERI Formwork Systems, Inc.
 Elkridge, MD 21075
 info@peri-usa.com
 www.peri-usa.com

08 Indonesia
 PT Beton Perkasa Wijaksana
 Jakarta 10210
 bpw@betonperkasa.com
 www.peri.com

09 Italy
 PERI S.p.A.
 20060 Basiano
 info@peri.it
 www.peri.it

10 Japan
 PERI Japan K.K.
 Tokyo 103-0015
 info@perijapan.jp
 www.perijapan.jp

11 United Kingdom/Ireland
 PERI Ltd.
 Rugby, CV23 0AN
 info@peri.ltd.uk
 www.peri.ltd.uk

12 Turkey
 PERI Kalıp ve İskeleleri
 Esenyurt / İstanbul 34510
 info@peri.com.tr
 www.peri.com.tr

13 Hungary
 PERI Kft.
 1181 Budapest
 info@peri.hu
 www.peri.hu

14 Malaysia
 PERI Formwork Malaysia
 Sdn. Bhd.
 43300 Seri Kembangan,
 Selangor Darul Ehsan
 info@perimalaysia.com
 www.perimalaysia.com

15 Singapore
 PERI ASIA Pte. Ltd
 Singapore 387355
 pha@periasia.com
 www.periasia.com

16 Austria
 PERI Ges.mbh
 3134 Nußdorf ob der Traisen
 office@peri.at
 www.peri.at

17 Czech Republic
 PERI spol. s r.o.
 252 42 Jesenice u Prahy
 info@peri.cz
 www.peri.cz

18 Denmark
 PERI Danmark A/S
 2670 Greve
 peri@peri.dk
 www.peri.dk

19 Finland
 PERI Suomi Ltd. Oy
 05460 Hyvinkää
 info@perisuomi.fi
 www.perisuomi.fi

20 Norway
 PERI Norge AS
 3036 Drammen
 info@peri.no
 www.peri.no

21 Poland
 PERI Polska Sp. z o.o.
 05-860 Płochocin
 info@peri.pl.pl
 www.peri.pl.pl

22 Sweden
 PERIform Sverige AB
 30013 Halmstad
 peri@periform.se
 www.periform.se

23 Korea
 PERI (Korea) Ltd.
 Seoul 135-080
 info@perikorea.com
 www.perikorea.com

24 Portugal
 PERIcofragens Lda
 2790-326 Queijas
 info@peri.pt
 www.peri.pt

25 Argentina
 PERI S.A.
 B1625GPA Escobar – Bs. As.
 info@peri.com.ar
 www.peri.com.ar

26 Brazil
 PERI Formas e
 Escoramentos Ltda.
 Vargem Grande Paulista
 São Paulo
 info@peribrasil.com.br
 www.peribrasil.com.br

27 Chile
 PERI Chile Ltda.
 Colina, Santiago de Chile
 peri.chile@peri.cl
 www.peri.cl

28 Romania
 PERI România SRL
 077015 Balotesti
 info@peri.ro
 www.peri.ro

29 Slovenia
 PERI Slovenien
 2000 Maribor
 peri.slo@triera.net
 www.peri.com

30 Slovakia
 PERI spol. s r.o.
 903 01 Senec
 info@peri.sk
 www.peri.sk

31 Australia
 PERI Australia Pty. Ltd.
 Glendenning NSW 2761
 info@periaus.com.au
 www.periaus.com.au

32 Estonia
 PERI AS
 76406 Saku vald
 Harjumaa
 peri@peri.ee
 www.peri.ee

33 Greece
 PERI Hellas Ltd.
 194 00 Koropi
 info@perihellas.gr
 www.perihellas.gr

34 Latvia
 PERI SIA
 2118 Salaspils novads,
 Rigas rajons
 info@peri-latvija.lv
 www.peri-latvija.lv

35 United Arab Emirates
 PERI (L.L.C.)
 Dubai
 perillc@perime.com
 www.perime.com



- 36 Canada**
PERI Formwork Systems, Inc.
Bolton, ON – L7E 1K1
info@peri.ca
www.peri.ca
- 37 Lebanon**
Lebanon Representative Office
Jdeideh
lebanon@peri.de
www.peri.de
- 38 Lithuania**
PERI UAB
02300 Vilnius
info@peri.lt
www.peri.lt
- 39 Morocco**
PERI S.A.
Tanger
peri25@menara.ma
www.peri.com
- 40 Israel**
PERI Formwork
Engineering Ltd
Petach Tikva, 49002
info@peri.co.il
www.peri.co.il
- 41 Bulgaria**
PERI Bulgaria EOOD
1839 Sofia
peri.bulgaria@peri.bg
www.peri.bg
- 42 Iceland**
Armar ehf.
220 Hafnarfjörður
www.armor.is
- 43 Kazakhstan**
TOO PERI Kazakhstan
050014 Almaty
peri@peri.kz
www.peri.kz
- 44 Russian Federation**
OOO PERI
142407, Noginsk District
moscow@peri.ru
www.peri.ru
- 45 South Africa**
Wiehahn Formwork and
Scaffolding (Pty) Ltd.
7600 Stellenbosch
info@wiehahn.co.za
www.wiehahn.co.za
- 46 Ukraine**
TOW PERI Ukraina
07400 Brovary
peri@peri.ua
www.peri.ua
- 47 Egypt**
Egypt Branch Office
11361 Heliopolis / Cairo
info@peri.com.eg
www.peri.com.eg
- 48 Serbia**
PERI Oplate d.o.o.
11272 Dobanovci
office@peri.rs
www.peri.rs
- 49 Mexico**
PERI Cimbras y Andamios,
S.A. de C.V.
Estado de México,
info@peri.com.mx
www.peri.com.mx
- 50 Azerbaijan**
PERI Kalıp ve İskeleleri
Baku
peribaku@peri.com.tr
www.peri.com.tr
- 51 Turkmenistan**
PERI Kalıp ve İskeleleri
Aşgabat
ahmet.kadioglu@peri.com.tr
www.peri.com.tr
- 52 Belorussia**
PERI Belarus
220030 Minsk
info@peri.by
www.peri.com
- 53 Croatia**
PERI oplate i skele d.o.o.
10 250 Donji Stupnik/
Zagreb
info@peri.com.hr
www.peri.com.hr
- 54 Iran**
PERI GmbH
Iran Branch Office
Tehran
info@peri.ir
www.peri.ir
- 55 India**
PERI (India) Pvt Ltd
Mumbai – 400064
info@peri.in
www.peri.in
- 56 Jordan**
PERI GmbH - Jordan
11947 Amman
jordan@peri.com
www.peri.com
- 57 Kuwait**
PERI Kuwait
13011 Kuwait
kuwait@peri.com
www.peri.com
- 58 Saudi Arabia**
PERI Engineering
Division of Jamjoom
Consult Saudi Arabia
21463 Jeddah
info@peri.com.sa
www.peri.com.sa
- 59 Qatar**
PERI Qatar LLC
P.O.Box: 31295 - Doha
info@periqatar.com
www.periqatar.com
- 60 Algeria**
Société PERI S.A.S.
Kouba - Alger
peri.alger@peri.fr
www.peri.fr
- 61 Albania**
PERI Sh.p.k.
Tirane
erti.hasanaj@peri.com.tr
www.peri.com.tr
- 62 Peru**
PERI Peruana SAC
Chorrillos, Lima
contacto@peri.com.pe
www.peri.com.pe
- 63 Panama**
PERI Panama Inc.
0832-00155 Panama City
info@peri.com.pa
www.peri.com.pa
- 64 Angola**
PERIcofragens, Lda.
Luanda
renato.portugal@peri.pt
www.peri.pt
- 65 Nigeria**
Heights Access Nigeria Ltd.
Victoria Island, Lagos
info@heightsaccessng.com
www.heightsaccessng.com
- 66 Oman**
PERI (L.L.C.)
Muscat
perimct@perime.com
www.perime.com

PERI Product Range



Wall Formwork

Panel Formwork
Girder Formwork
Circular Formwork
Facade Formwork
Brace Frame



Climbing Systems

Climbing Scaffold
Self-Climbing System
Climbing Protection Panel
Platform Systems



Column Formwork

Square
Rectangular
Circular



Scaffold, Stairways, Working Platforms

Facade Scaffold
Working Platform
Weather Protection Roof
Stairway Access



Slab Formwork

Panel Formwork
Beam Grid Formwork
Girder Formwork
Slab Table
Beam Formwork

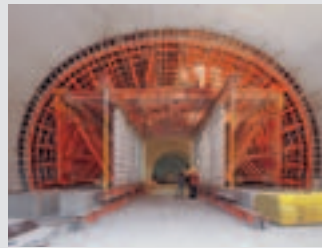

Bridge and Tunnel Formwork

Cantilevered Parapet Carriage
Cantilevered Parapet Platform
Engineer's Construction Kit



Shoring Systems

Steel Slab Props
Aluminium Slab Props
Tower Systems
Heavy-Duty Props



Services

Formwork Assembly
Cleaning / Repairs
Formwork Planning
Software
Statics
Special Constructions

Additional Systems

Safety Systems
Plywood
Formwork Girders
Sto pend Systems
Pallets
Transportation Containers



PERI GmbH Formwork Scaffolding Engineering

P.O. Box 1264
89259 Weissenhorn
Germany
Tel. +49 (0)7309.950-0
Fax +49 (0)7309.951-0
info@peri.com
www.peri.com