

# VARIOKIT VGB

## Parapet Track

Instructions for Assembly and Use – Standard Configuration – Version 2.0

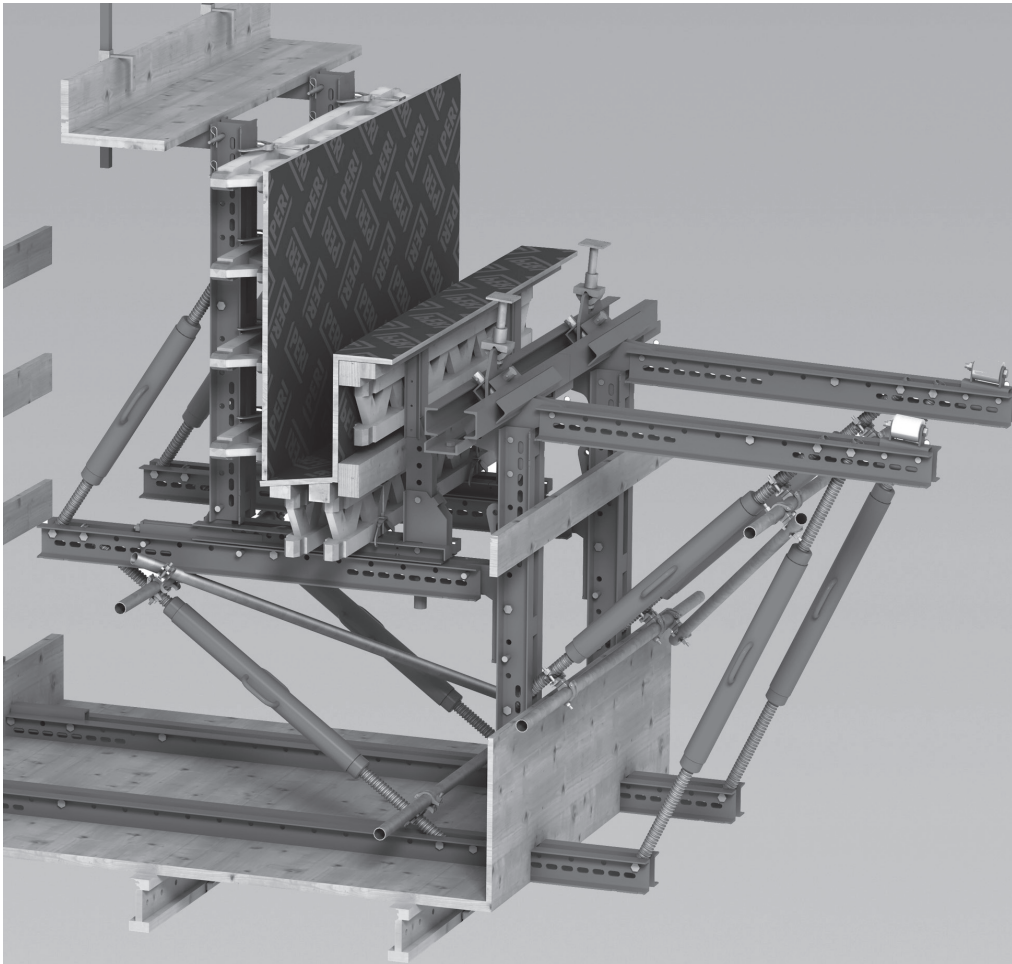

<b>Overview</b>			
Main components	3		
Key	4		
<b>Introduction</b>			
Target groups	5		
Additional technical documentation	5		
Intended use	6		
Instructions for Use	6		
Cleaning and maintenance instructions	7		
<b>Safety instructions</b>			
Cross-system	8		
System-specific	9		
Storage and transportation	9		
<b>Process planning</b>			
A1 Load conditions	10		
Working/concreting	10		
Moving the carriage	11		
A2 Pre-dimensioning	12		
Selecting the correct formwork assembly	14		
A3 Anchoring	16		
Positioning and installation of the ties	16		
A4 Fixing for suspension heads	20		
Suspension Anchor M24 VARIOKIT	20		
A5 Closing the tie holes	22		
A6 VARIOKIT elements	23		
Adjusting Unit VARIOKIT	23		
Modifying the Steel Waler SRU	23		
A7 Planking and lateral protection	24		
Planking	24		
Lateral protection	25		
Guardrail Post GKB	26		
<b>Assembly</b>			
B1 Assembling a standard concreting unit	30		
B2 Platform unit element 1	31		
B3 Platform unit element 2	33		
B4 Connecting the platform units	35		
B5 Leading and finishing platform	36		
Leading platform	36		
Finishing platform	37		
Assembling the guardrail holders	38		
B6 Ladder access	39		
B7 Parapet track	41		
Roller unit	41		
Preparing the auxiliary construction	42		
Assembling the auxiliary construction with leading and finishing platforms	43		
Assembling the auxiliary construction with standard platforms	44		
Attachment points for crane lifting gear	46		
Attachment points for PPE	47		
Lifting procedure: outer parapet	47		
Last concreting cycle	51		
Lifting out procedure	52		
Lifting procedure: middle parapet	53		
B8 Formwork type 1	54		
Internal formwork	54		
External formwork	54		
B9 Formwork type 2	55		
Internal formwork	55		
External formwork	55		
<b>Working on the construction site</b>			
C1 Basic settings before initial concreting work – Formwork type 1	56		
C2 Basic settings before initial concreting work – Formwork type 2	57		
C3 Shuttering – Formwork type 1	58		
C4 Shuttering – Formwork type 2	59		
C5 Concreting	60		
Concreting position	60		
C6 Striking procedure – Formwork type 1	61		
C7 Striking procedure – Formwork type 2	62		
C8 Relocating	63		
C8 Relocating	64		
C9 Horizontal holder	65		
<b>Lifting out</b>			
D1 Disassembly	66		
<b>Program overview</b>			
VGB Parapet Track	68		

## Main components

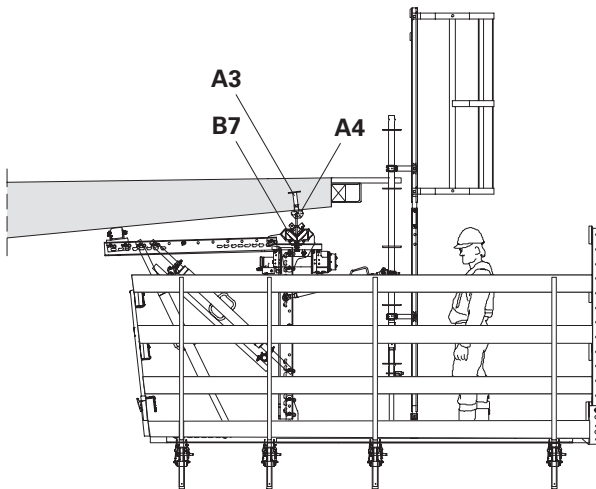
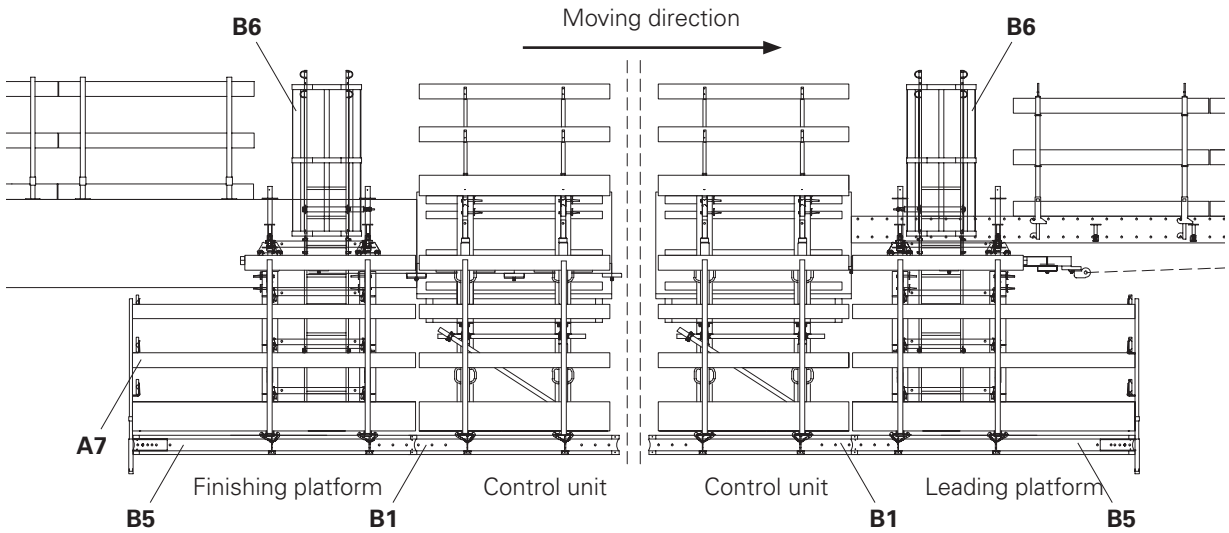

Side view of leading platform

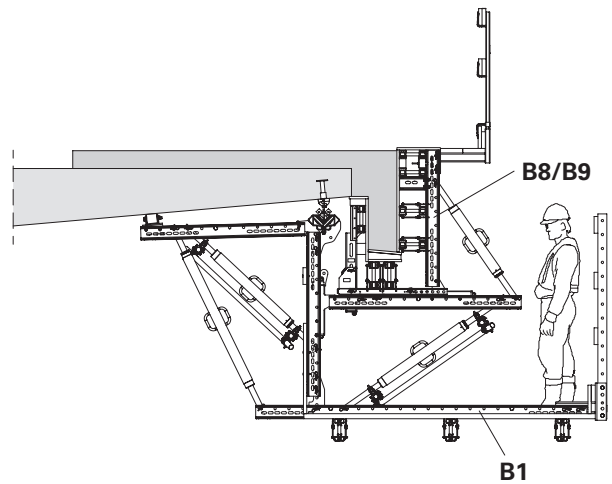

Side view of standard concreting unit

- A3 Anchoring
- A4 Fixing for suspension heads
- A7 Planking and lateral protection
- B1 Control unit
- B5 Leading platform/finishing platform
- B6 Ladder access
- B7 Roller units
- B8 Formwork type 1
- B9 Formwork type 2

## Key

### Pictogram | Definition



Danger/Warning/Caution



Note



To be complied with



Load-bearing point



Visual inspection



Tip



Incorrect use



Safety helmet



Safety shoes



Safety gloves



Safety goggles



Personal protective equipment to prevent falling from a height (PPE)

### Arrows



Arrow representing an action



Arrow representing a reaction of an action\*



Arrow representing forces

\* If not identical to the action arrow.

### Safety instruction categories

The safety instructions alert site personnel to the risks involved and provide information on how to avoid these risks. Safety instructions can be found at the beginning of the section or before instructions for action and are highlighted as follows:



#### Danger

This sign indicates an extremely hazardous situation which could result in death or serious, irreversible injury if the safety instructions are not followed.



#### Warning

This sign indicates a hazardous situation which could result in death or serious, irreversible injury if the safety instructions are not followed.



#### Caution

This sign indicates a hazardous situation which could result in minor or moderate injury if the safety instructions are not followed.



#### Note

This sign indicates situations in which failure to observe the information can result in material damage.

### Format of the safety instructions



#### Signal word

Type and source of hazard!  
Consequences of non-compliance.

⇒ Preventative measures.

### Dimensions

Dimensions are usually given in cm. Other measurement units, e.g. m, are shown in the illustrations.

### Conventions

- Instructions are numbered with: 1. ...., 2. ...., 3. ....
- The result of an instruction is shown by: →
- Position numbers are clearly provided for the individual components and are given in the drawing, e.g. **1**, in the text in brackets, for example (**1**).
- Multiple position numbers, i.e. alternative components, are represented with a slash: e.g. **1/2**.

### Notes on illustrations

The illustration on the front cover of these instructions is understood to be a system representation only. The assembly steps presented in these Instructions for Assembly and Use are shown in the form of examples with only one component size. They are valid for all component sizes contained in the standard configuration.

To facilitate understanding, detailed illustrations are sometimes incomplete. The safety equipment which might not have been shown in these detailed illustrations must nevertheless be available.

## Target groups

### Contractors

These Instructions for Assembly and Use are designed for contractors who either

- assemble, modify and dismantle formwork systems, or
- use them, e.g. for pouring concrete, or
- allow them to be used for other operations, e.g. carpentry or electrical work.

### Competent person

(Construction Site Coordinator)

The Safety and Health Protection Coordinator\*

- is appointed by the client,
- must identify potential hazards during the planning phase,
- determines measures that provide protection against risks,
- creates a safety and health protection plan,
- coordinates the protective measures for the contractor and site personnel so that they do not endanger each other,
- monitors compliance with the protective measures.

### Competent persons qualified to carry out inspections

Due to the specialist knowledge gained from professional training, work experience and recent professional activity, the competent person qualified to carry out inspections has a reliable understanding of safety-related issues and can carry out inspections correctly. Depending on the complexity of the inspection to be undertaken, e.g. scope of testing, type of testing or the use of certain measuring devices, a range of specialist knowledge is necessary.

### Qualified personnel

Formwork systems may only be assembled, modified or dismantled by personnel who are suitably qualified to do so. Qualified personnel must have completed a course of training\*\* in the work to be performed, covering the following points at least:

- Explanation of the plan for the assembly, modification or dismantling of the formwork in an understandable form and language.
- Description of the measures for assembling, modifying or dismantling the formwork.

- Naming of the preventive measures to be taken to avoid the risk of persons and objects falling.
- Naming of the safety precautions in the event of changing weather conditions which could adversely affect the safety of the formwork system as well as the persons concerned.
- Details regarding permissible loads.
- Description of all other risks and dangers associated with assembly, modification or dismantling operations.



- **In other countries, ensure that the relevant national guidelines and regulations in the respective current version are complied with!**
- **If no country-specific regulations are available, it is recommended to proceed according to German guidelines and regulations.**
- **A competent person must be present on site during formwork operations.**

\* Valid in Germany: Regulations for Occupational Health and Safety on Construction Sites 30 (RAB 30).

\*\* Instructions are given by the contractor themselves or a competent person selected by them.

---

## Additional technical documentation

- Approvals:
  - Approval Z-21.6-1768 PERI Anchor Sleeve M24
- Instructions for Use:
  - Lifting Eye BR-2 2.5 t
  - Concrete cones and concrete adhesives
- Assembly instructions:
  - VGB Pulling Unit

## Intended use

### Product description

PERI products have been designed for exclusive use in the industrial and commercial sectors only by suitably trained personnel.

The parapet track is used for concreting cantilevered parapets cast in-situ or prefabricated concrete bridges.

The parapet track can be flexibly adapted to suit different parapet geometries and carriageway radii.

Main components are standardised PERI components taken from the VARIOKIT Engineering Construction Kit.

The basis is formed by two parallel brackets consisting of Steel Walers SRU and Spindles SLS, which form a platform unit with spacings of 1.00 m, 1.25 m or 1.50 m depending on the size of the parapet and bridge radius. Both brackets are thereby connected by means of guide rails 100 and 150 as well as wind bracing and other reinforcement.

Optimum adaptation to the respective parapet geometry takes place via the Formwork Support VARIOKIT and Adjusting Unit VARIOKIT.

The system is anchored by means of the PERI Anchor Sleeve M24 that is concreted into the bridge superstructure, on which the Roller Unit VARIOKIT is mounted using the Suspension Anchor M24 VARIOKIT.

### Features

- No impairment on and under the bridge due to suspension on the bridge cantilever.
- Mobile solution for a fast relocation procedure.
- Shuttering and striking in two steps.
- The roller unit can transfer the concreting loads without any additional measures.
- There is the option of combining the parapet track with a hydraulic winch system in order to pull it to the next concreting section.

### Technical data

- Possible widths of influence:
  - 1.00 m
  - 1.25 m
  - 1.50 m
- Project-specific planning required.
- Recommended track length: 25 m
- Anchoring screw: ISO 4014 M24x150-8.8-VZ
- Total weight results from the project-specific planning.
- Temperature range:
  - -20°C to +60°C

---

## Instructions for Use

Use in a manner not intended, deviating from the standard configuration, project-specific planning documents or the intended use detailed in the Instructions for Assembly and Use, represents a misapplication with a potential safety risk, e.g. risk of falling.

Only PERI original components may be used. The use of other products and spare parts is not allowed.

Changes to PERI components are not permitted.

The system described in these Instructions for Assembly and Use may contain patent-protected components.

## Cleaning and maintenance instructions

In order to maintain the value and operational readiness of the formwork materials over the long term, clean the panels after each use.

Some repair work may also be inevitable due to the tough working conditions.

The following instructions should help to keep cleaning and maintenance costs as low as possible.

Spray the formwork on both sides with concrete release agent before each use; this facilitates easier and faster cleaning of the formwork. Spray the concrete release agent very thinly and evenly!

Spray the rear side of the formwork with water immediately after concreting; this avoids any time-consuming and costly cleaning operations.

When used continuously, spray the formlining elements with concrete release agent immediately after striking; then clean by means of a scraper, brush or rubber lip scraper.

Important: do not clean formlining made of plywood with high-pressure equipment. This could result in the formlining being damaged.

Fix recesses and built-in parts with double-headed nails; as a result, the nails can easily be removed later, and damage to the formlining is largely avoided.

Close all unused tie holes with plugs; this eliminates any subsequent cleaning or repair work.

Tie holes accidentally blocked with concrete are cleared by means of a steel pin from the formlining side.

When placing bundles of reinforcement bars or other heavy objects on horizontally stored formwork elements, suitable support, e.g. square timbers, is to be used: this prevents impressions and damage to the formlining to a large extent.

Internal concrete vibrators should be fitted with rubber caps if possible; as a result, any damage to the formlining is reduced if the vibrator is accidentally inserted between the reinforcement and formlining.

Never clean powder-coated components, e.g. elements and accessories, with a steel brush or hard metal scraper; this ensures that the powder coating remains intact.

Use spacers for reinforcement with large-sized supports or extensive areas of support; this largely avoids impressions being formed in the formlining when under load.

Mechanical components, e.g. spindles or gear mechanisms, must be cleaned of dirt or concrete residue before and after use, and then greased with a suitable lubricant.

Provide suitable support for the components during cleaning so that no unintentional change in their position is possible.

Do not clean components suspended on crane lifting gear.

## Cross-system

### General

The contractor must guarantee that the Instructions for Assembly and Use supplied by PERI are available at all times and understood by the site personnel.

These Instructions for Assembly and Use can be used as the basis for creating a risk assessment. The risk assessment is compiled by the contractor. However, the Instructions for Assembly and Use are not a substitute for a risk assessment!

Observe and comply with the safety instructions and permissible loads.

For the application and inspection of PERI products, the current safety regulations and guidelines valid in the respective countries must be observed.

Materials and working areas are to be inspected on a regular basis, especially before each use and assembly, for:

- Damage,
- stability and
- function.

Damaged components must be exchanged immediately on site and may no longer be used.

Safety components are to be removed only when they are no longer required.

Components provided by the contractor must comply with the characteristics stipulated in these Instructions for Assembly and Use and all applicable laws and standards. Unless otherwise indicated, the following applies in particular:

- Timber components: strength class C24 for solid wood according to EN 338.
- Scaffolding tubes: galvanised steel tubing with minimum dimensions  $\varnothing 48.3 \times 3.2$  mm according to EN 12811-1:2003 4.2.1.2.
- Scaffold tube couplings according to EN 74.

Deviations from the standard configuration are only permitted after a further risk assessment has been carried out by the contractor.

Appropriate measures for working and operational safety, as well as stability, are defined on the basis of this risk assessment.

Corresponding proof of stability can be provided by PERI on request, if the risk assessment and resulting measures to be implemented are made available.

Before and after exceptional occurrences that may have an adverse effect on the safety of the formwork system, the contractor must immediately

- produce another risk assessment and make use of its results to take suitable steps to guarantee the stability of the formwork system,
- arrange for an extraordinary inspection to be carried out by a competent person qualified to do so. The aim of this inspection is to identify and rectify any damage in good time in order to guarantee safe use of the formwork system.

Exceptional events could be:

- accidents,
- long periods of non-use,
- natural events, e.g. heavy rainfall, icing, heavy snowfall, storms or earthquakes.

### Assembly, modification and dismantling work

Assembly, modification or dismantling of formwork systems may only be carried out by qualified persons under the supervision of a competent person. The qualified personnel must have received appropriate training for the work to be carried out with regard to specific risks and dangers.

On the basis of the risk assessment and the Instructions for Assembly and Use, the contractor must create installation instructions to guarantee safe assembly, modification and dismantling of the formwork system.

The contractor must ensure that the personal protective equipment required for the assembly, modification or dismantling of the formwork system, e.g.

- safety helmets,
- safety shoes,
- safety gloves,
- safety goggles,

is available and used as intended.

If personal protective equipment against falling from a height (PPE) is required or specified in local regulations, the contractor must determine appropriate attachment points on the basis of the risk assessment.

The PPE against falling from a height that is to be used is determined by the contractor.

The contractor must

- provide safe working areas for site personnel, which are to be reached through the provision of safe access ways. cordon off and clearly mark danger zones.
- guarantee stability during all stages of construction, in particular during assembly, modification and dismantling operations.
- ensure and demonstrate that all loads that occur are safely transferred.

### Use

Every contractor who uses or allows formwork systems or sections of the formwork to be used, is responsible for ensuring that the equipment is in good condition.

If the formwork system is used successively or at the same time by several contractors, the health and safety coordinator must point out any possible mutual hazards and all work must be then coordinated.



## System-specific

Project-specific planning is required each time a parapet track is assembled, e.g. a detailed static calculation.

Strike components only when the concrete has sufficiently hardened and the person in charge has given the go-ahead for striking to take place.

If the hydraulic winch is used to pull the parapet track, only the operator is allowed to remain on the leading platform in order to control the system.

During the pulling procedure, leading edges are created. Suitable safety measures to prevent falling must be implemented.

The following is not permitted:

- Overloading the pulling unit.
- Overloading the suspension point.
- Site personnel are not allowed to remain in the area of the hydraulic winch during the moving procedure.

## Anchoring

Anchoring is to take place only if the anchorage has sufficient concrete strength.

During the assembly of the scaffold anchoring and the installation of the bracket scaffold, the contractor entrusted with this or the competent person appointed by them must be present. This ensures that the work is properly completed. Verification of the existing concrete strength as well as the inspection of single components, proper assembly and the anchoring depth must be documented. Proof must be provided that all load transfers in the building are distributed into the ground.

Damaged anchoring components or advanced mountings must not be used.

Examples of damage:

- deformed components
- rough or scratched surfaces
- rough-running/deformed threads
- deformed hex. thread in Metric Threaded Cone M24/40
- widened nail hole in Metric Threaded Cone M24/40

## Storage and transportation

Store and transport components in such a way that no unintentional change in their position is possible. Detach lifting accessories and lifting gear from the lowered components only if they are in a stable position and no unintentional change is possible.

Do not drop the components.

Use PERI lifting accessories and lifting gear and only those load-bearing points provided on the component.

During the relocation procedure

- ensure that components are picked up and set down in such a way that unintentional falling over, falling apart, sliding, falling down or rolling is avoided.
- no one is allowed to remain under the suspended load.

The access areas on the construction site must be free of obstacles and tripping hazards, and must also be slip-resistant.

For transportation, the substrate must have sufficient load-bearing capacity.

Use original PERI storage and transport systems, e.g. crate pallets, pallets or stacking devices.



## Danger

Load specifications must not be exceeded!

Risk of falling for the VGB Parapet Track.

- ⇒ Do not place any materials or other objects anywhere on the VGB Parapet Track.
- ⇒ Ensure that the load transfer takes place centrally in the Rail VGB ( $\pm 10$  cm).
- ⇒ For "Load Case: Concreting," only access the work platform to carry out inspection work.

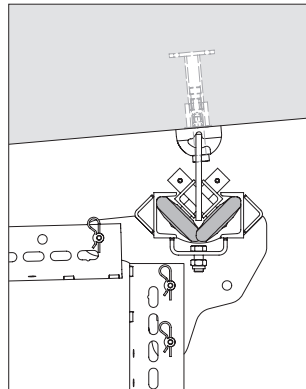

Fig. A1.01

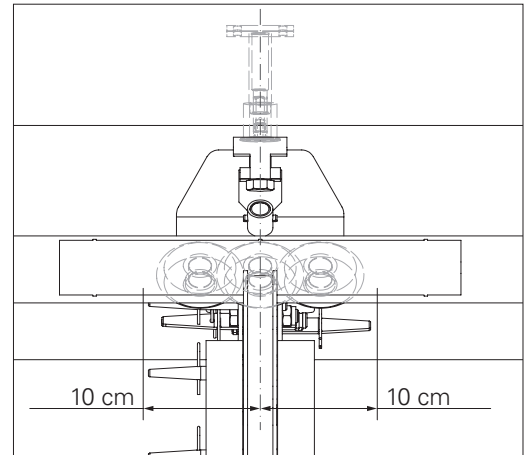

Fig. A1.02

## Working/concreting



The supporting structure of the VGB Parapet Track is to be provided with project-specific verification by means of a static calculation on the basis of PERI product information as well as valid standards.

Anchoring verification (load transfer into the concrete) according to General Building Approval No.: Z-21.6-1768 PERI Anchor Sleeve M24.

Proof must be provided that all load transfers in the building are distributed into the ground.

Work procedures in "Load Case: Working":

- Cleaning the formwork,
- Installing reinforcement in the cantilevered parapet,
- Closing the formwork,
- Concreting,
- Striking,
- Inspection and maintenance.

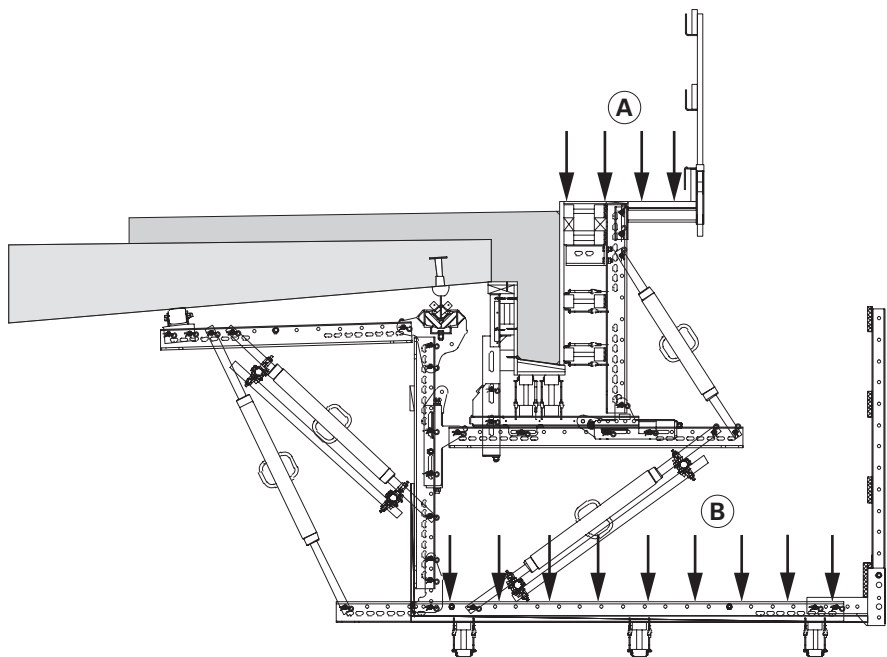

Fig. A1.03

Load Case: Working/Concreting	
Live Load A	0.75 kN/m <sup>2</sup>
Live Load B	0.75 kN/m <sup>2</sup>
Max. working wind speed	0.20 kN/m <sup>2</sup> (vW = 64 km/h)
Fresh concrete pressure	in accordance with the static calculation

Tab. A1.01

Load case: Storm	
Live Load A	0.00 kN/m <sup>2</sup>
Live Load B	0.00 kN/m <sup>2</sup>
Wind gust velocity	in accordance with the static calculation
Fresh concrete pressure	in accordance with the static calculation

Tab. A1.02

## Moving the carriage



### Danger

Unsecured concrete edge!

A fall can result in serious injuries or even death

Risk of falling.

- ⇒ Assembly and dismantling should take place from a safe and secure working area, e.g. lifting platform, or
- ⇒ Use PPE.



- Load specifications must not be exceeded.
- Do not place any materials or other objects anywhere on the VGB Parapet Track.

### Preparation

Before movement begins, the formwork must be released from the building by turning the Heavy-Duty Spindles SLS **(2a)** and **(2b)** or **(2c)**. (Fig. A1.04 and Fig. A1.05)



Transport freed-up

Roller Units VARIOKIT **(7)** when moving the VGB Parapet Track via the cantilevered parapet track to the leading platform. (see Section C8)

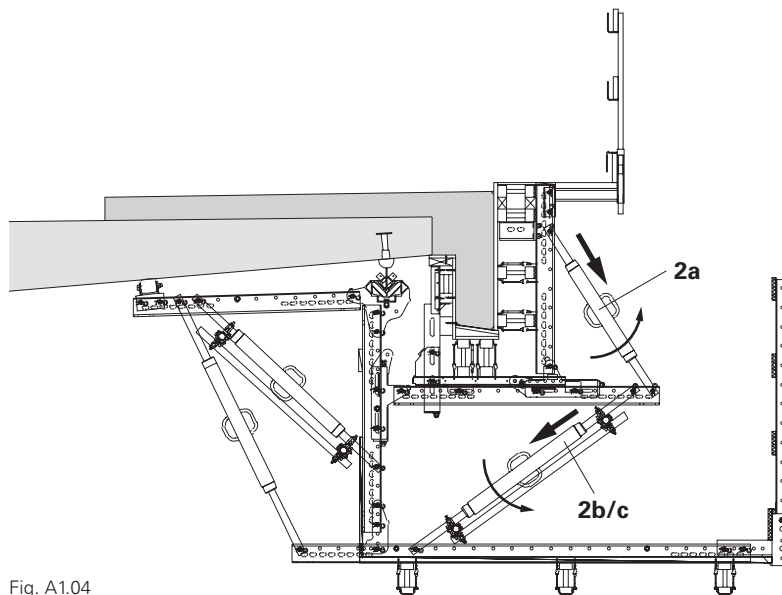

Fig. A1.04

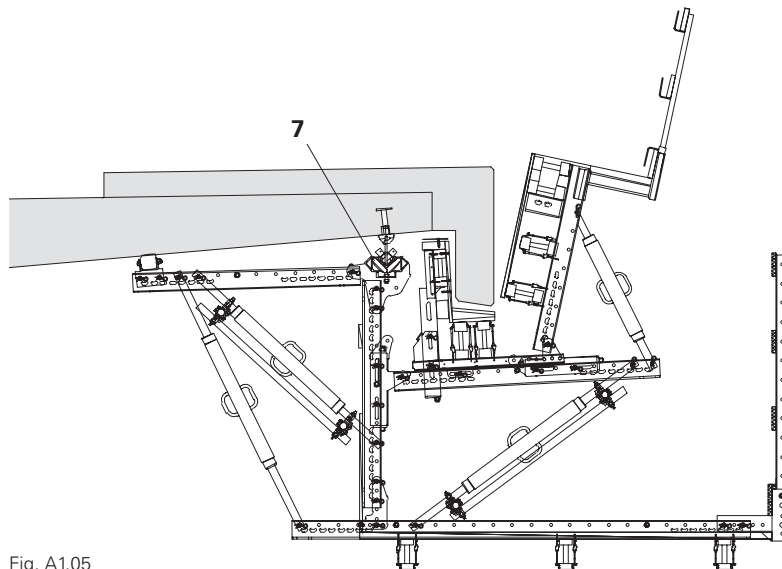

Fig. A1.05

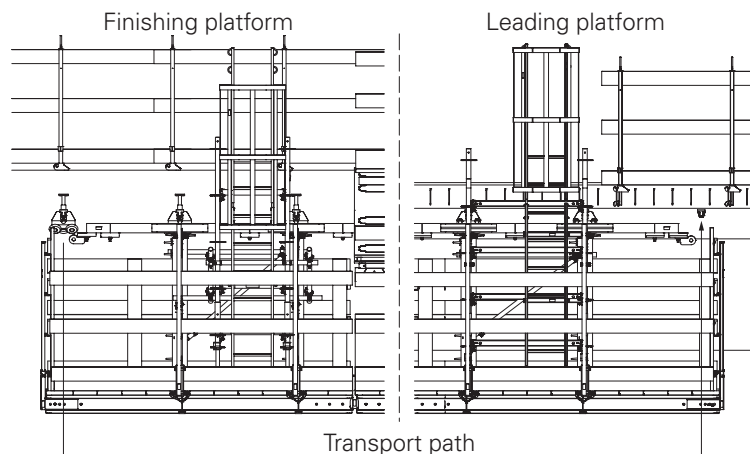

Fig. A1.06

### Load Case: Moving

Live Load A	0.00 kN/m <sup>2</sup>
Live Load B	0.75 kN/m <sup>2</sup>
Max. working wind speed	0.20 kN/m <sup>2</sup> (v <sub>W</sub> = 64 km/h)

Tab. A1.03



The dimensions and geometric dependencies shown in Fig. A2.01 are important for pre-dimensioning! A project-specific static calculation is always required.

**Standard components:**

- 1c** Steel Waler Universal SRU U120  
L = 1.22 m
- 1d** Steel Waler Universal SRU U120  
L = 1.47 m
- 1e** Steel Waler Universal SRU U120  
L = 1.72 m
- 1f** Steel Waler Universal SRU U120  
L = 2.97 m
- 2a** Heavy-Duty Spindle SLS 80/140
- 2b** Heavy-Duty Spindle SLS 100/180
- 2c** Heavy-Duty Spindle SLS 140/240
- 7** Roller Unit VARIOKIT

(Fig. A2.01)

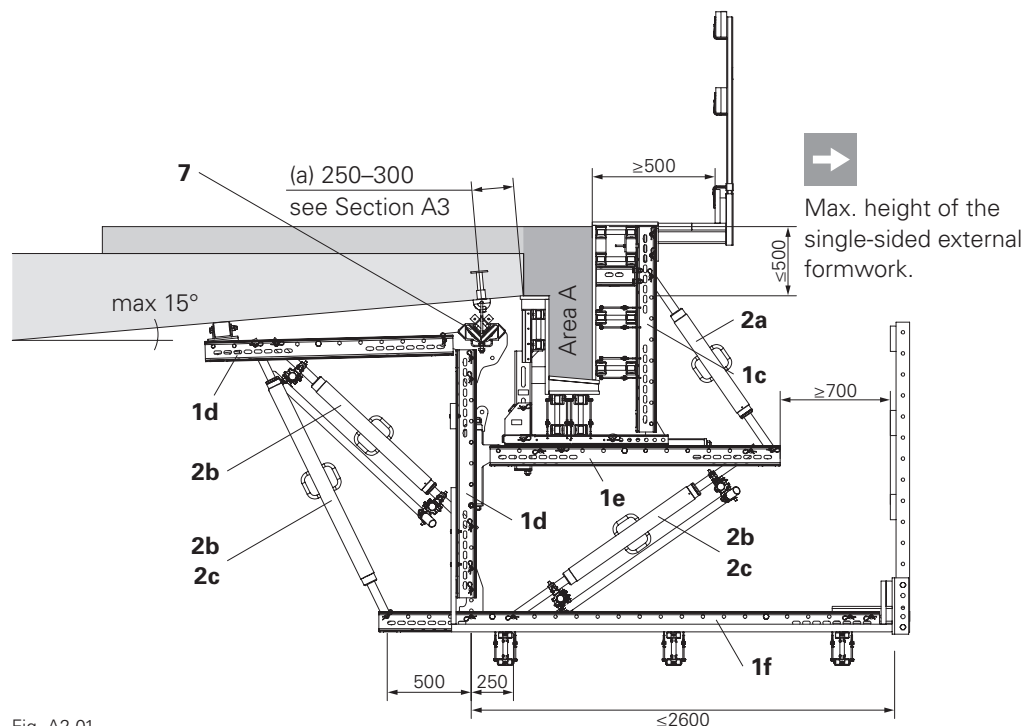

Fig. A2.01

## Permissible tie spacings depending on parapet size:

Tie spacing b2 (Fig. A2.02)	1000 mm
max. parapet area A (Fig. A2.01)	0.6 m <sup>2</sup>

→ Anchoring may become decisive.

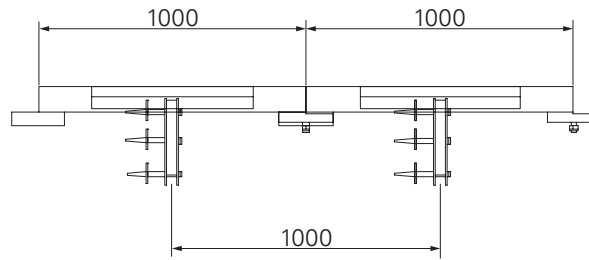

Fig. A2.02

Tie spacing b2 (Fig. A2.03)	1250 mm
max. parapet area A (Fig. A2.01)	0.4 m <sup>2</sup>

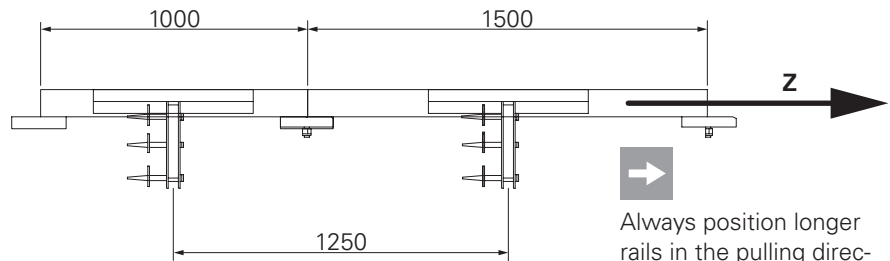

Fig. A2.03

Always position longer rails in the pulling direction (**Z**).

Tie spacing b2 (Fig. A2.04)	1500 mm
max. parapet area A (Fig. A2.01)	0.2 m <sup>2</sup>

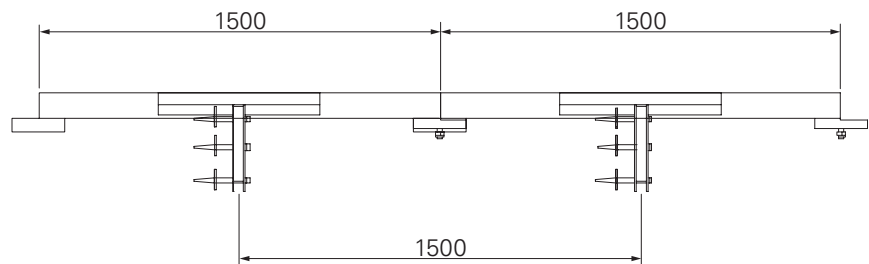

Fig. A2.04

## Selecting the correct formwork assembly

### Type 1 Parapets with large projection on the inner side (>10 cm with formwork support)



Always place the external formwork on the bottom element.  
(Fig. A2.05a)

- With the adjustable Vertical Post VGB 100 (3), the internal formwork can be adapted to suit the structure separately from the external formwork. (Fig. A2.05)
- By turning the bolt (AF 30), the standard can be adjusted by  $\pm 5.0$  cm. (Fig. A2.05b)

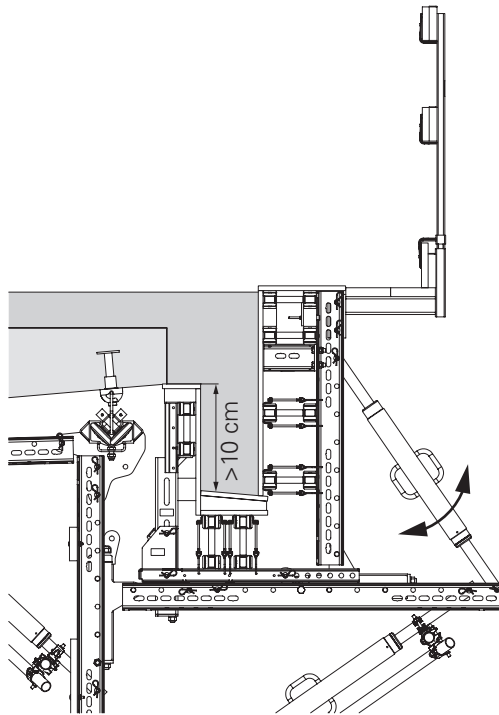

Fig. A2.05

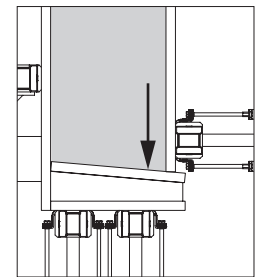

Fig. A2.05a

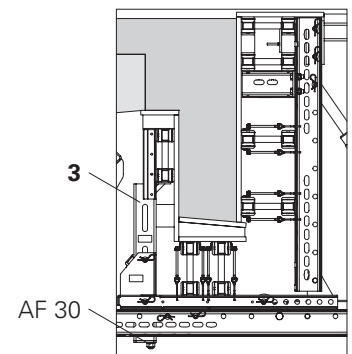

Fig. A2.05b

## Type 2 Parapets with small projection on the inner side ( $\leq 10$ cm in height)



Always place the external formwork on the bottom element.

- For parapets with an inner parapet height up to 10 cm, the Adapter VGB (4) and Lift Protector SRU (5) are used. (Fig. A2.06a)
- The internal formwork is pressed against the formwork girder with Wingnut Pivot Plate DW 15 (8) by means of a Tie Rod DW 15 (6). (Fig. A2.06b)
- Hammer the internal formwork in an upwards direction and fix with wedges. The formwork is optimally adapted to suit the structure.

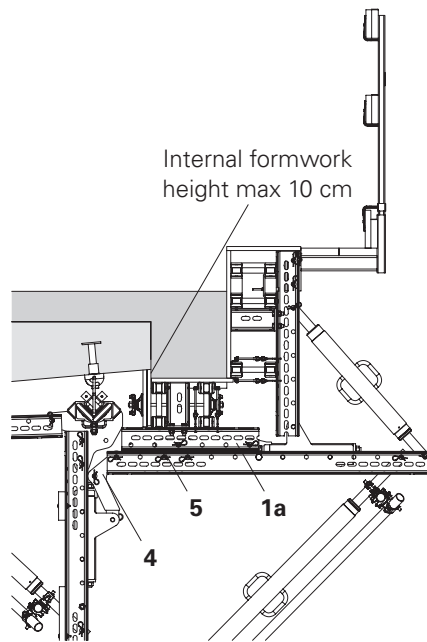

Fig. A2.06

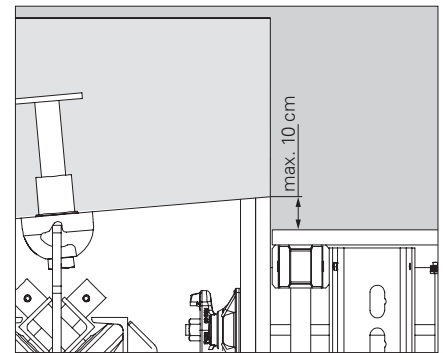
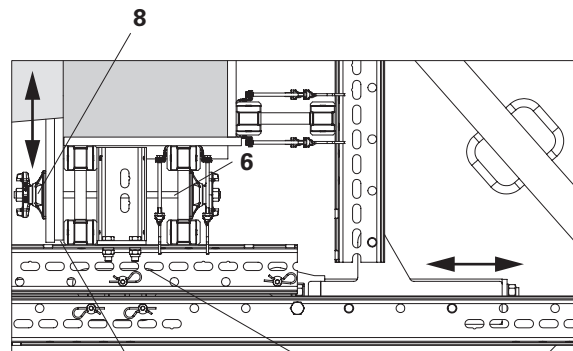

Fig. A2.06a



Wedges for pressing the formwork

Fig. A2.06b

## Positioning and installation of the ties



Check anchoring components and advance mountings for any signs of damage prior to installation.

### Tie spacing in a longitudinal direction

3 different tie spacings (b2) are possible depending on the parapet size and bridge gradient: 1.00 m, 1.25 m and 1.50 m.

The connection of the parapet in the area of the abutment is planned on a project-specific basis. The spacing to the abutment wall (b1) is determined from the cantilever of the standard platform unit, as well as a dimension tolerance of 5.0 cm according to the reference values in Tab. A3.01.

Damaged anchoring components or advanced mountings must not be used.

Examples of damage:

- deformed components
- rough or scratched surfaces
- rough-running/deformed threads
- deformed hex. thread in Metric Threaded Cone M24/40
- widened nail hole in Metric Threaded Cone M24/40



### Check installation

- edge distance,
- spacing,
- completely screwed in,
- planned position.

Tie inspection by a competent person and the reinforcement acceptance process can be carried out at the same time. PERI recommends compiling an acceptance report.

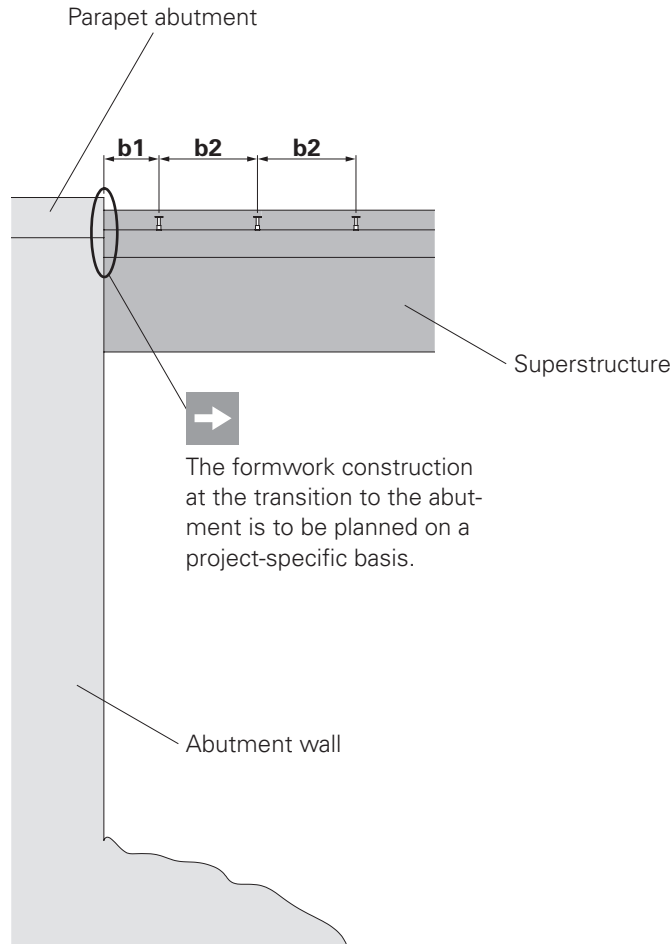

The formwork construction at the transition to the abutment is to be planned on a project-specific basis.

Fig. A3.01

Rails [Type]	b1 [cm]	b2 [cm]
100/100	65	100
100/150	65	125
150/150	90	150

Tab. A3.01



## Anchor Sleeve M24

The Anchor Sleeve M24 (9) is also embedded when concreting the cantilevered parapet.



- Dimension "a": see Approval Z-21.6-1768 PERI Anchor Sleeve M24
- Maintain the selected dimension "b" over the entire length of the bridge. (Fig. A3.03)

## Anchor Positioning Stud M24 x 65

### Required components per tie point

9	Anchor Sleeve M24	1x
10	Anchor Positioning Stud M24	1x
11	Cone FRC Ø 32/52	1x

### Installation with anchor positioning stud

1. Mount Anchor Positioning Stud M24 (10) on the formwork panel by means of 4x wire nails 3 x 80. (Fig. A3.02)  
Note: edge distance "a" and distance to sides "b1" and "b2". (Fig. A3.03 + Tab. A3.01)
2. Push Cone FRC Ø 32/52 (11) over the thread of the anchor positioning stud.
3. Screw Anchor Sleeve M24 (9) onto the Anchor Positioning Stud M24 as far as it will go. (Fig. A3.03)
4. Secure the Anchor Sleeve M24 (9) in the reinforcement using tie wire.

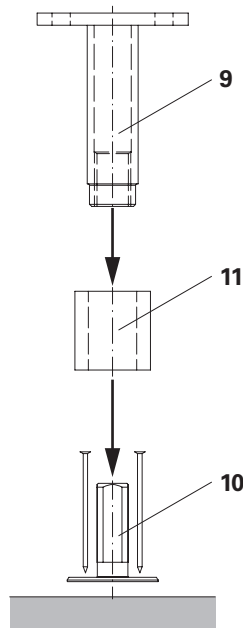

Fig. A3.02

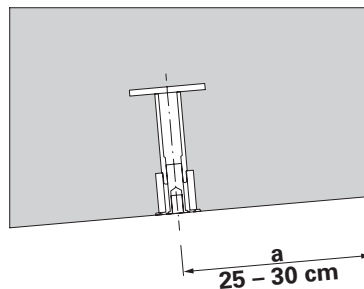

Fig. A3.03

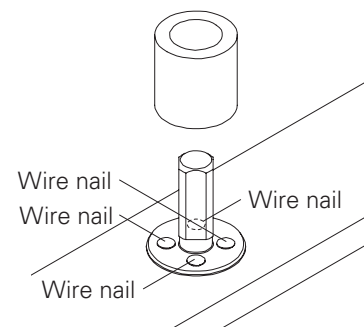

Fig. A3.03a

## Metric Threaded Cone M24/40

### Required components per tie point

<b>9</b> Anchor Sleeve M24	1x
<b>12</b> Threaded Cone M24/40	1x
<b>13</b> Wire nail Ø 4.6 x 130	1x

### Installation with threaded cone

1. Insert wire nail Ø 4.6 x 130 (**13**) into the Threaded Cone M24/40 (**12**).
2. Position the Threaded Cone M24/40 (**12**) on the formlining and hammer in the wire nail Ø 4.6 x 130 (**13**) all the way. (Fig. A3.04)
3. Grease thread with solvent-free grease/lubricating spray.
4. Screw in Anchor Sleeve M24 (**9**) as far as possible, at 90° to the formwork panel. (Fig. A3.05)
5. Secure the Anchor Sleeve M24 (**9**) in the reinforcement with tie wire to ensure that it does not change its position during concreting.

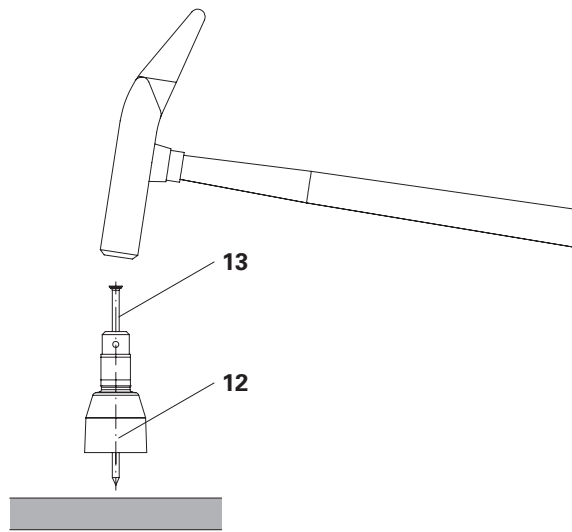

Fig. A3.04

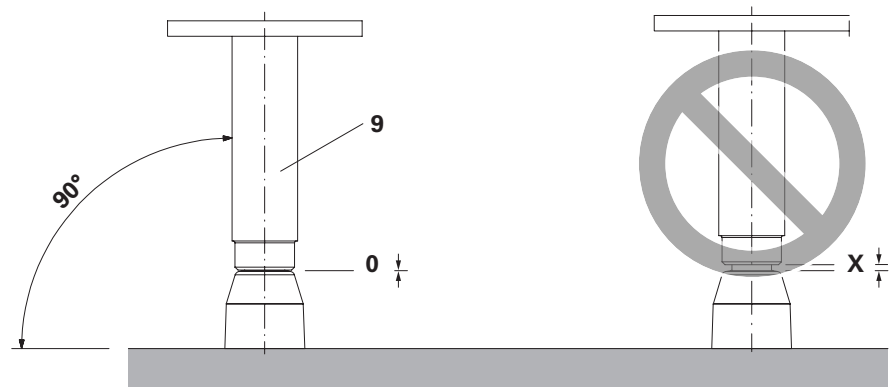

Fig. A3.05



### Check installation

- Edge distance
- Anchor spacings
- Ensure the Anchor Sleeve is completely screwed in
- Planned position

Tie and reinforcement checks can be done at the same time.



Carefully grease the surfaces of the Threaded Cone M24/40 (**12**) that come into contact with concrete with suitable grease. This facilitates the disassembly of the Threaded Cones M24/40 (**12**).



## Suspension Anchor M24 VARIOKIT



Installation of the Suspension Heads M24 VARIOKIT is carried out from a safe working position, e.g.

- leading platform of the VGB Parapet Track
- telescopic work platform
- temporary working scaffold



- Dimension "a": see Approval Z-21.6-1768 PERI Anchor Sleeve M24.
- The advanced mounting of Anchor Sleeve M24 is gradually removed during the Parapet Track VGB relocation procedure and the Suspension Anchor M24 VARIOKIT is fastened immediately after.
- Hand-tighten the screws to prevent them from twisting.

### Removing the anchor positioning stud

1. Turn over wire nails with a hammer.
2. Unscrew the Anchor Positioning Stud M24 (10) from the anchor sleeve by means of an Allen key (AF 14). (Fig. A4.01)

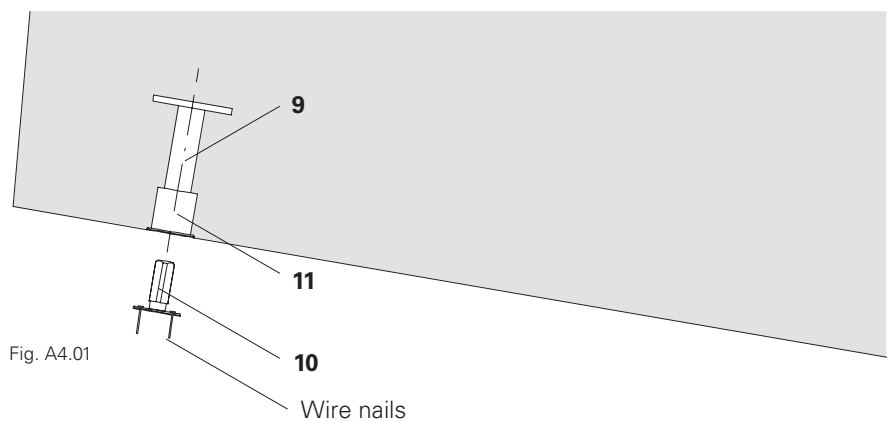

Fig. A4.01

### Removing the threaded cone

1. Push back wire nail with a hammer.
2. Unscrew Threaded Cone M24/40 (12) from the anchor sleeve using a ratchet wrench and socket (AF 22).

### Mounting the suspension head



Do not exceed max. permissible inclination of the Suspension Head M24 VARIOKIT. ( $\pm 15^\circ$ )

### Assembly

1. Attach Suspension Anchor M24 VARIOKIT (14) to the Anchor Sleeve M24 by means of bolt M24 x 150 (15). (Fig. A4.02)

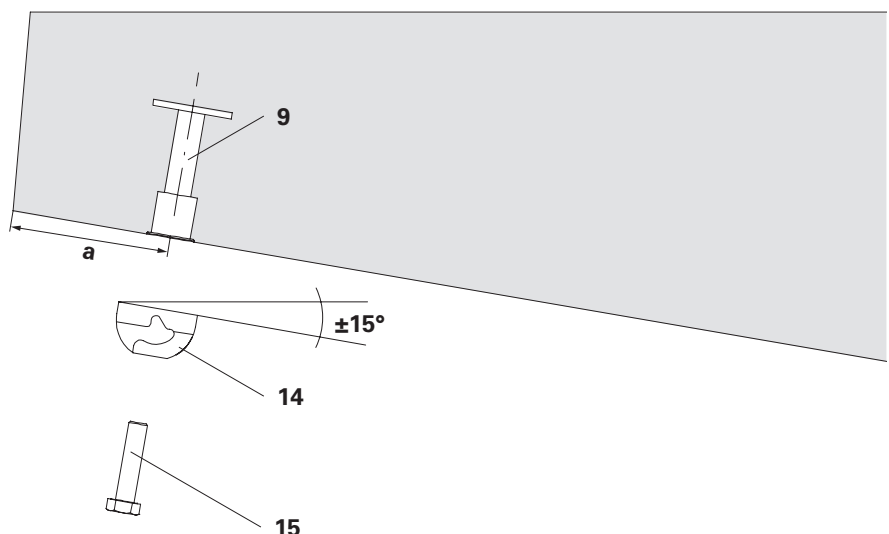

Fig. A4.02



For parapets with large projections, PERI recommends mounting the Suspension Anchor M24 VARIOKIT with the opening to the bridge superstructure to allow easier dismantling of the roller units.  
(Fig. A4.02a)

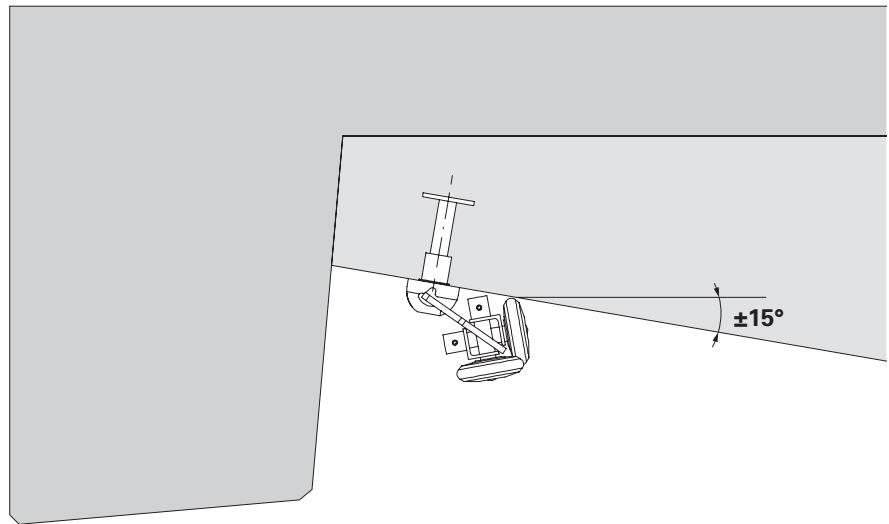

Fig. A4.02a



The process of closing the tie holes is carried out from a safe working position, e.g.:

- the finishing platform of the VGB Parapet Track
- telescopic work platform
- temporary working scaffold

### Dismantling

1. Release bolts M24 x 150 (**15**) in the Suspension Anchor M24 VARIOKIT (**14**).
2. Remove the Suspension Anchor M24 VARIOKIT (**14**).



Comply with the safety data sheet for the Repoxal adhesive.

### Closing the tie hole at the fibre cement pipe

1. Clean tie hole.
2. Mix adhesive (**16**) according to the manufacturer's instructions.
3. Immerse Plug FRC 32/20 (**17b**) in the adhesive on one side.
4. Tap into tie hole using a rubber-headed hammer until flush with hole.
5. Remove adhesive residue with a spatula (Fig. A5.01)

### Closing the tie hole at the threaded cone

1. Clean tie hole.
2. Mix adhesive (**316**) according to the manufacturer's instructions.
3. Immerse Plug FRC 40/20 (**17a**) in the adhesive on one side.
4. Tap into tie hole using a rubber-headed hammer until flush with hole.
5. Remove adhesive residue with a spatula.

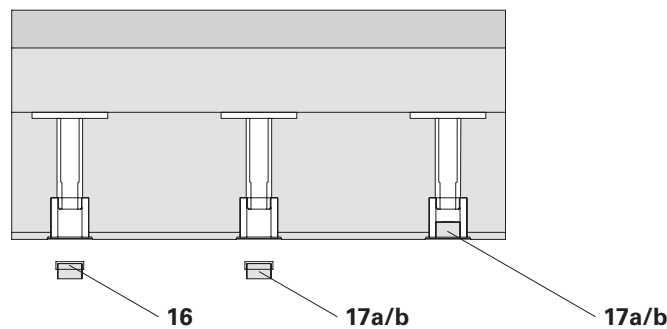

Fig. A5.01

## Adjusting Unit VARIOKIT

The Adjusting Unit VARIOKIT (**18**) is installed with the bolts in the middle position.

By turning the Adjusting Bolt AF 30, the Adjusting Unit VARIOKIT (**18**) ± can be moved flexibly 6.5 cm in the Steel Waler SRU U120 (**1e**) or (**1d**).

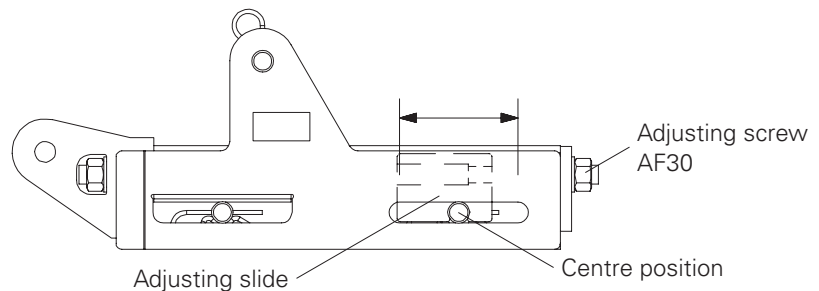

Fig. A6.01

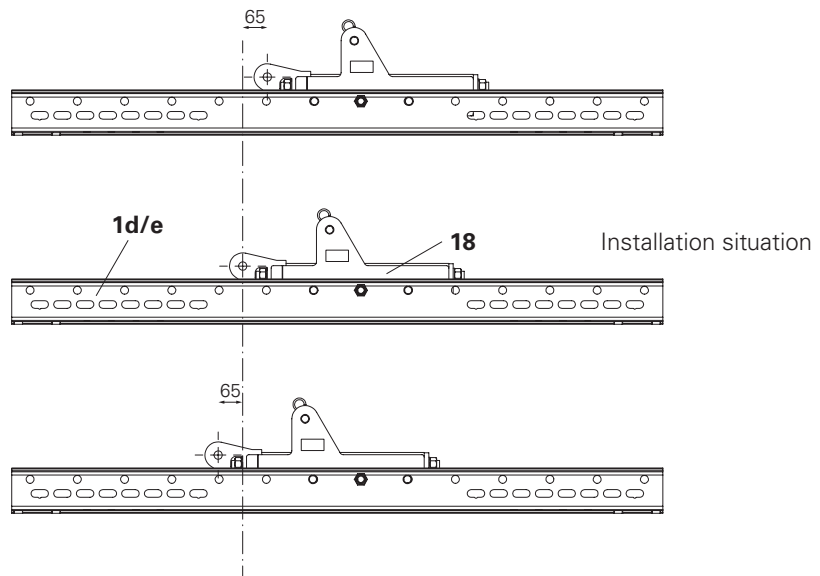

Fig. A6.02

## Modifying the Steel Waler SRU

If a built-in part collides with a spacer, the spacer must be moved.

The spacer must be reinstalled in the nearest free position.

### Removal and installation

1. Loosen bolt M20 and remove it.
2. Remove the sleeve.
3. Insert the sleeve in the new position.
4. Insert and tighten bolt M20.



After dismantling the VARIOKIT Adjusting Unit (**18**), move the spacer to its original position again.

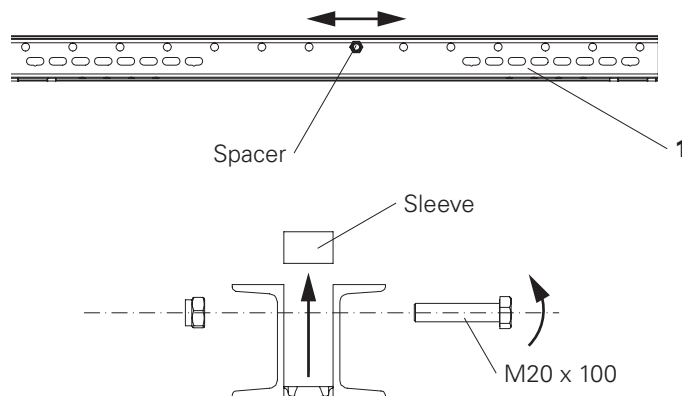

Fig. A6.03



- Only access the VGW Parapet Carriage once it has been checked and approved by the construction site management or another competent person.
- Separate static proof is required for the installation of cantilevered planking.

## Planking

Dimensioning of the platform planking is carried out according to the country-specific, applicable standards. (For Germany, DIN 4420-1 can be used.)

## Assembly

1. The planking is to be fixed to the beams at each intersection point using nails or screws. (Fig. A7.01)

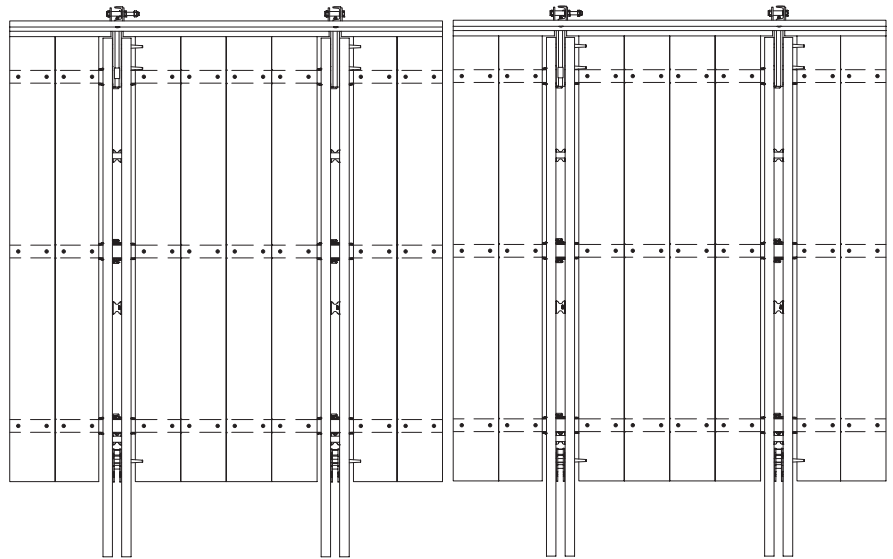

Fig. A7.01



## Lateral protection



- Dimension lateral protection in accordance with EN 12811.
- All leading edges are to be provided with guardrail protection.
- Lateral protection and toe boards are to be fixed to guardrail posts at every intersection point using nails or screws.
- For lateral protection on the bridge superstructure, the Guardrail Post GKB can be used.
- Lateral protection must also be mounted at the rear section of the control unit. (Fig. A7.02)

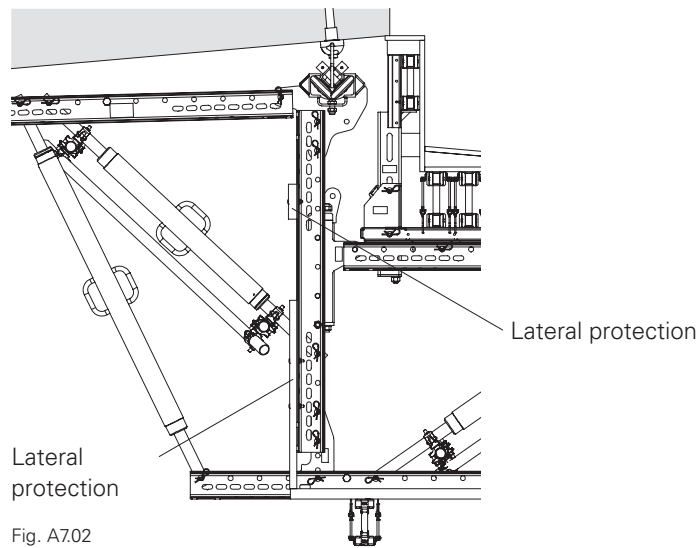

Fig. A7.02

## Variant for full enclosure



The full enclosure variant results in increased areas exposed to the wind and must be taken into consideration in the project-related static. (Fig. A7.02a)

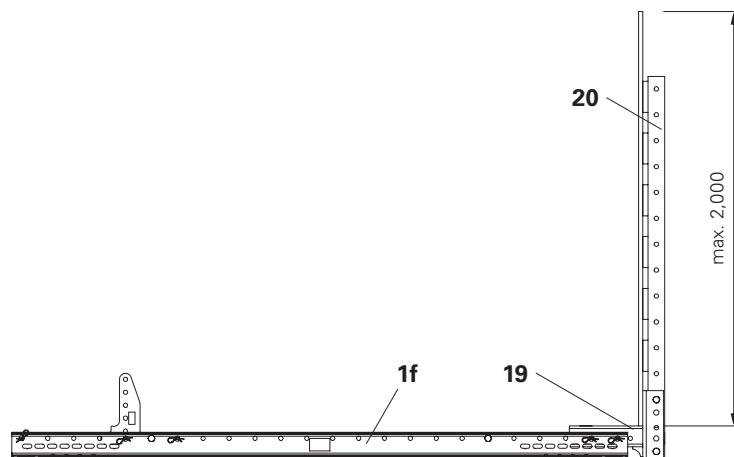

Fig. A7.02a

## Guardrail Post GKB



### Danger

Unsecured concrete edge!

A fall can result in serious injuries or even death

Risk of falling.

- ⇒ Assembly and dismantling should take place from a safe and secure working area, e.g. lifting platform, or
- ⇒ Use PPE.



- All loads that arise must be safely transferred.
- Reinforcement stirrups must have sufficient load-bearing capacity.

The Guardrail Post GKB is to be used in accordance with EN 13374 for temporary fall protection on bridge edges. Install side guardrails in accordance with Tab. A7.01 or Tab. A7.02.

Two fastening variants are available:

### Variant 1

The Guardrail Post GKB is clamped in the reinforcement stirrup. (Fig. A7.03)

### Required components

<b>21</b> Guardrail Post GKB	1x
<b>22</b> Guardrail boards	3x

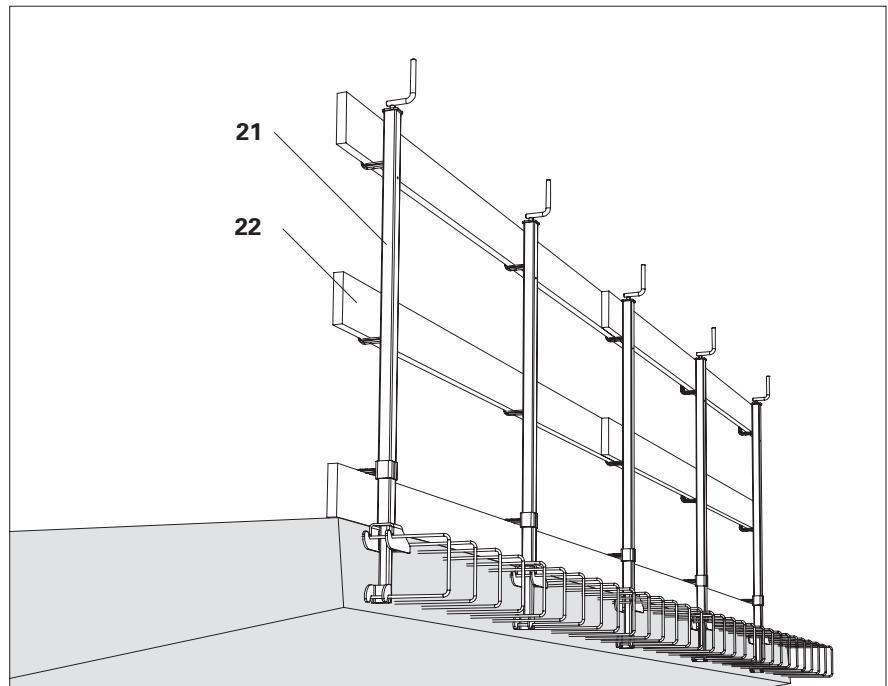

Fig. A7.03

### Permissible width of influence for the guardrail posts

Handrail board h/b [cm]	perm. width of influence* [m]
12/4	1.60
15/3	1.55

\* Values are valid only in compliance with the boundary conditions in Tab. A7.02 and Fig. A7.03b

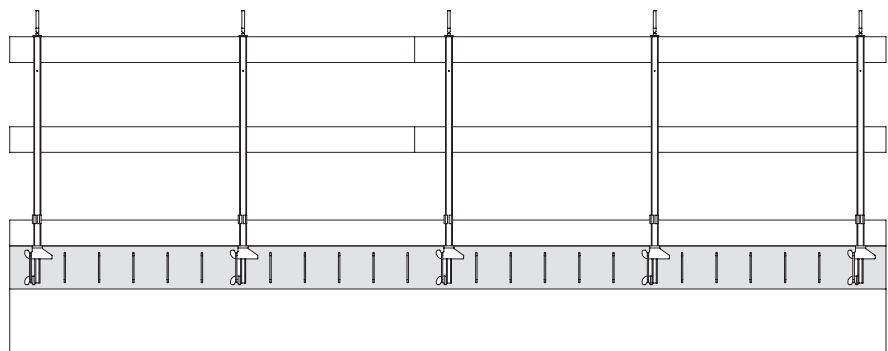

Fig. A7.03a

## Assembly

1. Pre-adjust Guardrail Post GKB (21) with the crank.
2. Place the Guardrail Post GKB (21) in the reinforcement stirrup and tension with the crank.
3. Position guardrail boards (22) and secure, e.g. by means of wire pins or wood screws. (Fig. A7.04 + A7.05)

## Disassembly

1. Turn crank until the lower holder is free and the guardrail post can be removed from the top reinforcement.

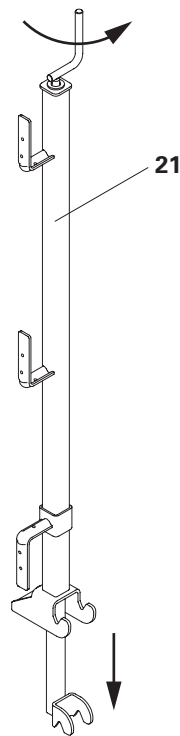

Fig. A7.04

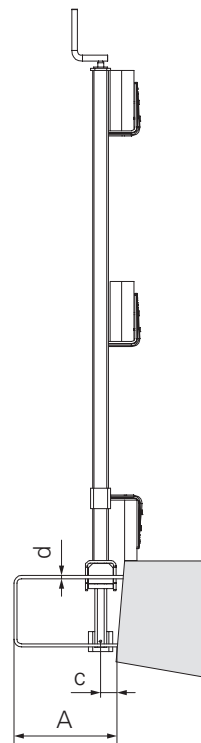

Fig. A7.05

Boundary conditions	
Tightening torque with the crank	$\geq 60$ Nm
Reinforcement stirrup spacing A	$\geq 15$ cm
Reinforcement stirrup diameter d	$\geq 12$ mm
Distance between axis/guardrail post and front side of concrete c	$\leq 6$ cm

Tab. A7.02

## Variante 2

The Guardrail Post GKB is fixed to the parapet/bridge.  
(Fig. A7.05c)

### Required components

<b>21</b> Guardrail Post GKB	1x
<b>23</b> Screw-On Sleeve PERI M16/164	1x
<b>24</b> Bolt ISO 4017 M16 x 120-8.8	1x
<b>25</b> Washer ISO 7094 100 HV, A16	1x



- For installation of the Screw-On Sleeve PERI M16/164 (**23**), see data sheet. (Fig. A7.07)
- Tighten and slightly tension the bolt M16 x 120 (**24**) together with washer ISO 7094 100 HV, A16 (**25**). (Fig. A7.05a + A7.05b + A7.06)

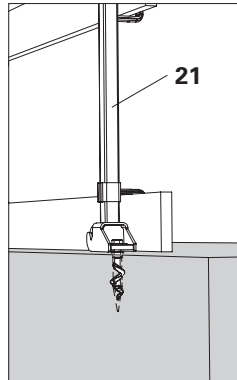

Fig. A7.05a

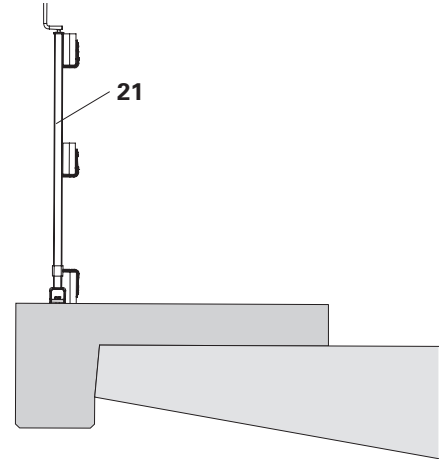

Fig. A7.05b

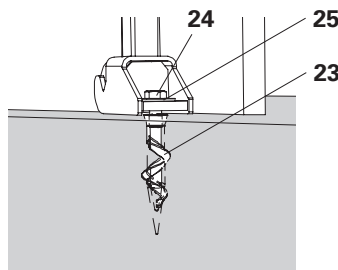

Fig. A7.05c

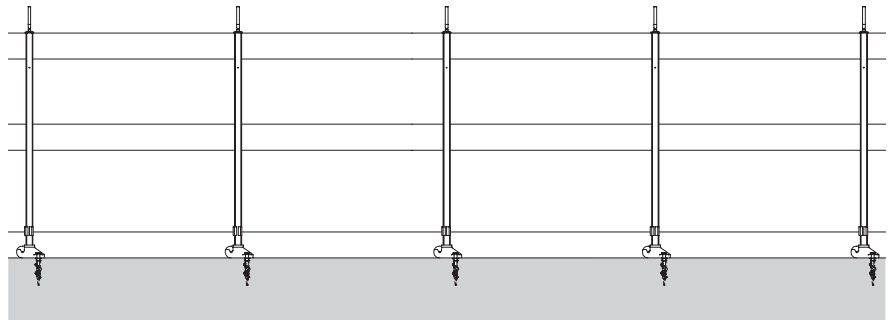

Fig. A7.06

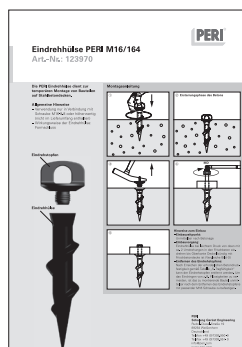
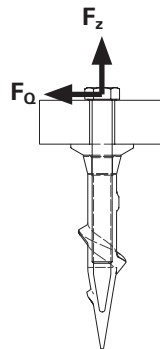

Fig. A7.07

## Permissible width of influence for the guardrail posts when using the PERI Screw-On Sleeve



- The forces shown in the table can be linearly reduced or increased when using other anchoring methods with smaller or larger influence widths.
- The permissible influence width in variant 2 is limited:
  - Handrail board h/b = 12 cm/4 cm: perm. influence width = 1.50 m
  - Handrail board h/b = 15 cm/3 cm: perm. influence width = 1.20 m
- For handrail boards that extend across only 2 bays, the permissible influence width of the guardrail post is to be divided by 1.25.
- Safe transfer of existing forces into the building must be guaranteed.
- Take into account the manufacturer's information on the selected anchoring.



Guardrail boards h/b [cm]	perm. width of influence* [m]	tensile force $F_z$ on anchoring [kN]	shear force $F_0$ on anchoring [kN]
12/4	1.20	9.89	0.53
15/3	0.95	9.74	0.53

\* Values are valid only in compliance with the boundary conditions in Tab. A7.04

Tab. A7.03

Boundary conditions	
Tightening torque with the crank	$\geq 60$ Nm
Reinforcement stirrup spacing A	$\geq 15$ cm
Reinforcement stirrup diameter d	$\geq 12$ mm
Distance between axis/guardrail post and front side of concrete c	$\leq 6$ cm

Tab. A7.04



- For installation, a crane or other lifting device as well as a level assembly surface is required.
- Intermediate states must be correctly secured by means of temporary supports to prevent any tipping over.



- PERI recommends having a sufficiently large area available for temporary storage purposes.
- Delivery of pre-assembled units is possible on request.

The specified quantity of fitting pins to be installed is based on the two-dimensional supporting structure of the platforms in each case. Ensure that each platform unit consists of 2 of these supporting structures. Secure all fitting pins  $\varnothing 21 \times 120$  (26) with cotter pins 4/1, galv. (27).

### Element assembly sequence of the standard concreting unit

- A** Platform unit
- B** Slab formwork
- C** Side formwork

(Fig. B1.01)

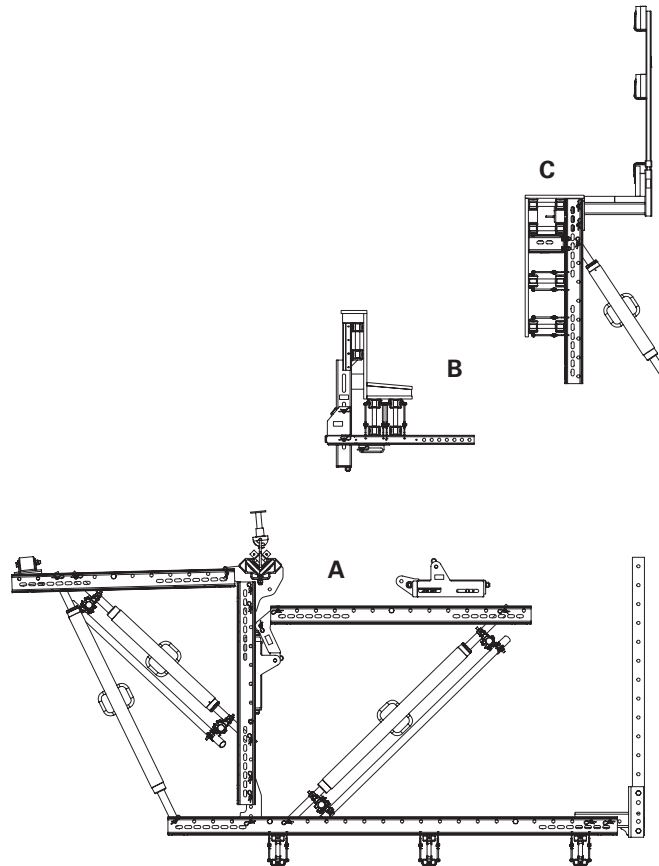

Fig. B1.01

Depending on the tie spacing (b2), this results in the following platform geometry:

b2	1.00 m	1.25 m	1.50 m
d	1.98 m	2.48 m	2.98 m
<b>VT 20K (28)</b>	2.15 m	2.45 m	2.90 m

Tab. B2.01

### Assembly of the platform unit

1. Fix Girder VT 20K (28) to the Steel Waler SRU U120 (1f) with the Hook Strap HBU (29).
2. Attach Hook Strap HBU (29) to the Girder VT 20 (28) by means of 8x TSS Torx 8 x 35. (Fig. B2.01a)
3. Install planking. (see Section A7)
4. Bolt Connector SRU VARIOKIT (30) onto the Steel Waler SRU U120 (1f) using 1x fitting pin Ø 21 mm (26).
5. Bolt Heavy-Duty Spindle SLS (2b) or (2c) onto the Steel Waler SRU U120 (1f) using 1x fitting pin Ø 21 mm (26). (Fig. B2.02b)
6. Bolt Angle Connector RCS/SRU (19) onto the Steel Waler SRU U120 (1f) using 1x fitting pin Ø 21 mm (26). (Fig. B2.02a)
7. Attach Guardrail Post RCS/SRU 184 (20) to the Angle Connector RCS/SRU (19) with Spacer RCS 184 (31) and the 2 bolts M20. (Fig. B2.02a)

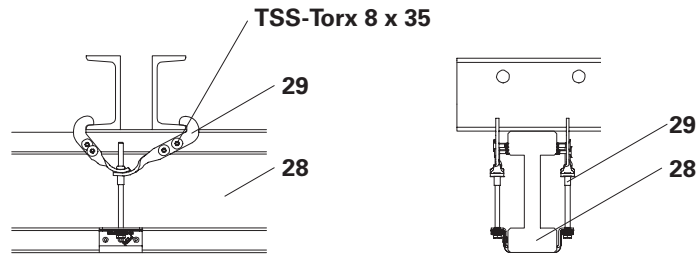

Fig. B2.01a

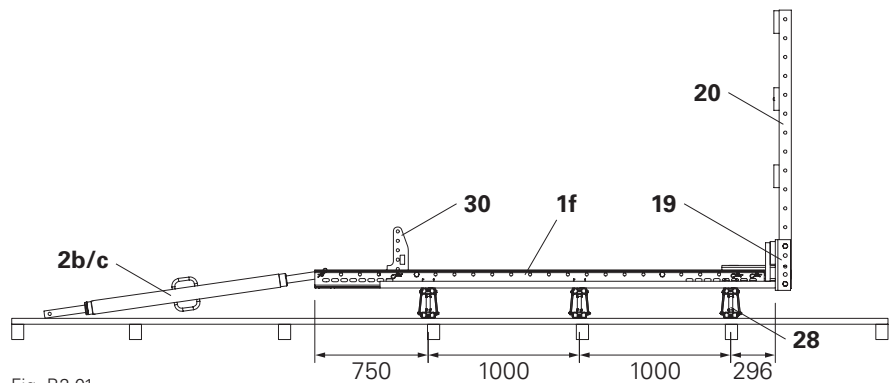

Fig. B2.01

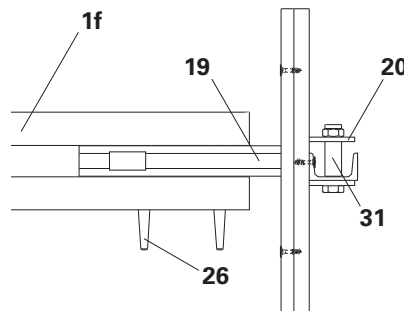

Fig. B2.02a

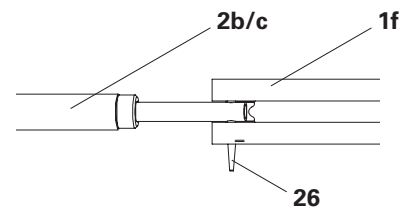

Fig. B2.02b

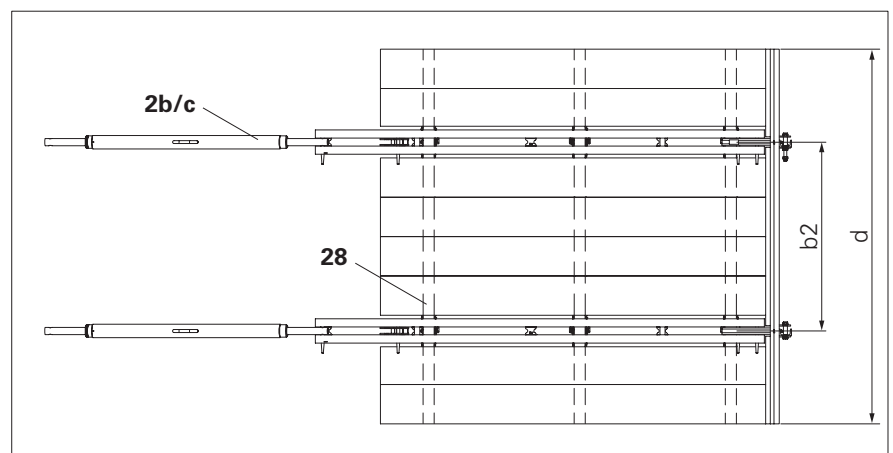

Fig. B2.02

For the variant with tie spacing  $b_2 = 1.00$  m, the Girder VT 20K (**28**) must be fixed from platform to platform in an offset position to the Steel Walers SRU U120 (**1f**) as shown. (Fig. B2.03)



Project-specific planning for bridge radii must be taken into consideration.

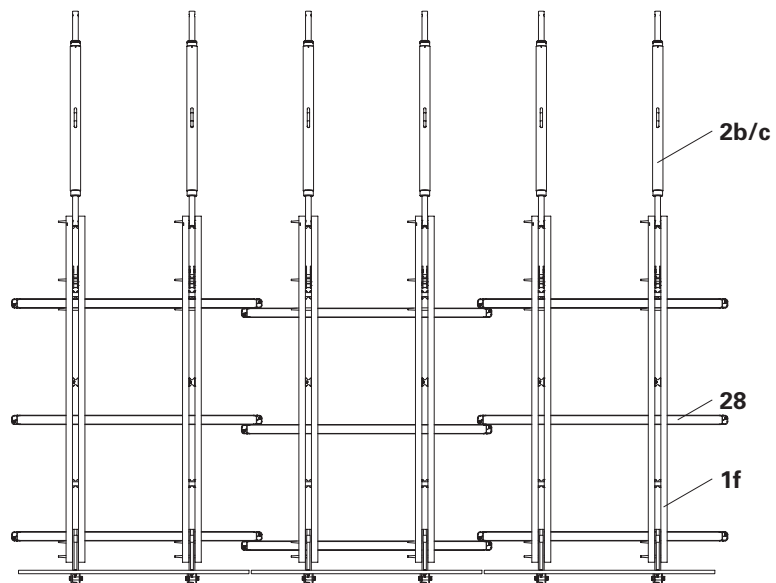

Fig. B2.03



### Taking the tie spacing into consideration

By combining the Rails 100 (**32a**) and 150 (**32b**), a tie pattern (b2) of 1.25 m can be realised. In this case, it is recommended that the Guide Rail 150 (**32b**) is always arranged in front of Rail 100 (**32a**) in the pulling direction (**Z**). (Fig. B3.01)

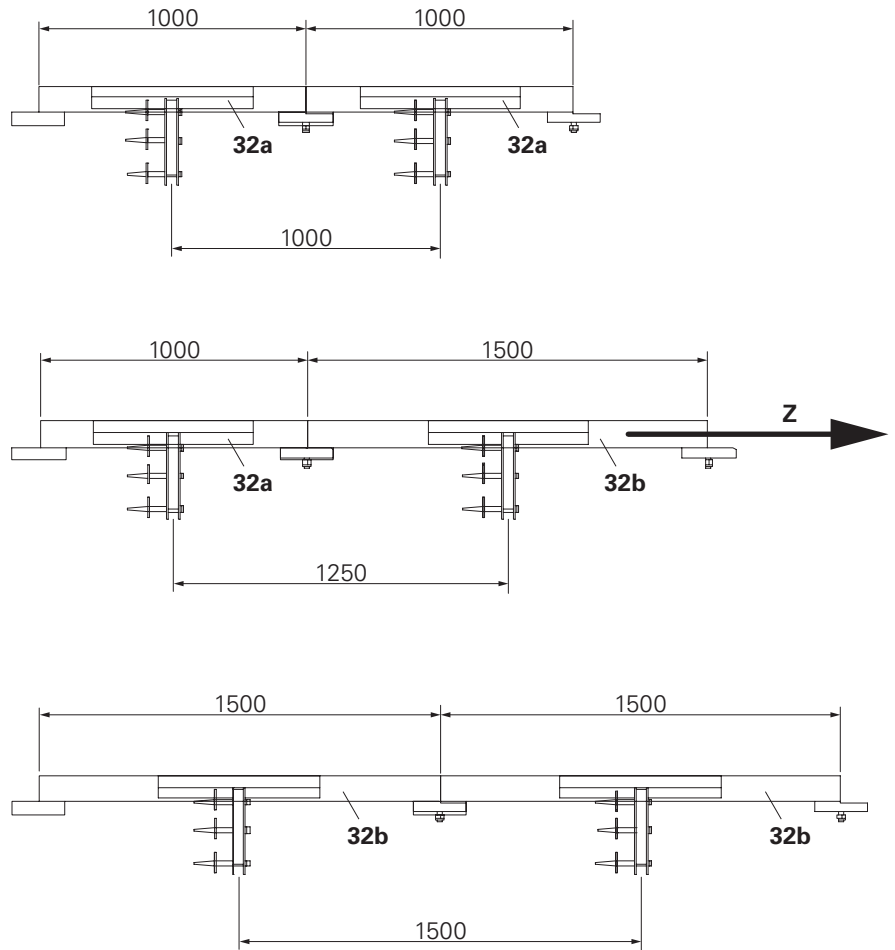

Fig. B3.01

## Assembly of variant b2 = 100 cm

(b2 = 125/150 cm are analogous)

1. Assemble Rails 100 VARIOKIT (32a) at the connecting plate joint and connect using bolts M20 x 45. (Fig. B3.02a)
2. Bolt the Steel Waler SRU U120 (1d) vertically onto the Rail 100 VARIOKIT (32a) using 2x fitting pins Ø 21 mm (26). (Fig. B3.02)
3. Bolt the Steel Waler SRU U120 (1d) horizontally onto the Rail 100 VARIOKIT (32a) using 1x fitting pin Ø 21 mm (26).
4. Install the Heavy-Duty Spindle SLS (2b) using 2x fitting pins Ø 21 mm (26).
5. Install the Pressure Roller VARIOKIT (33) using 2x fitting pins Ø 21 mm (26).
6. Fit horizontal steel scaffolding tubes (34a) using Standard Couplers RA 48/48 (35) on the threads of the Heavy-Duty Spindles SLS 100/180 (2b) (top and bottom).
7. Attach diagonal steel scaffolding tube (34b) to the horizontal steel scaffolding tubes (34a) with swivel coupling AF 48/48 (36). (Fig. B3.03a)

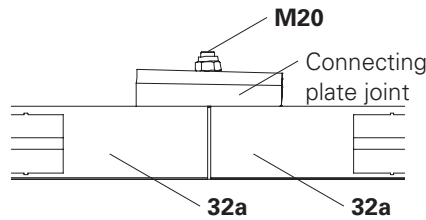

Fig. B3.02a

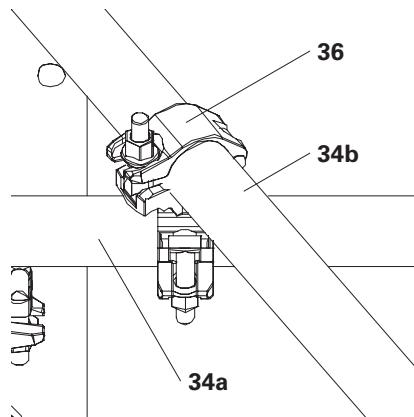

Fig. B3.03a

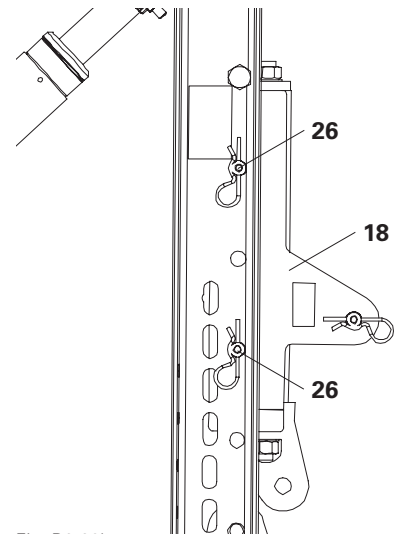

Fig. B3.02b

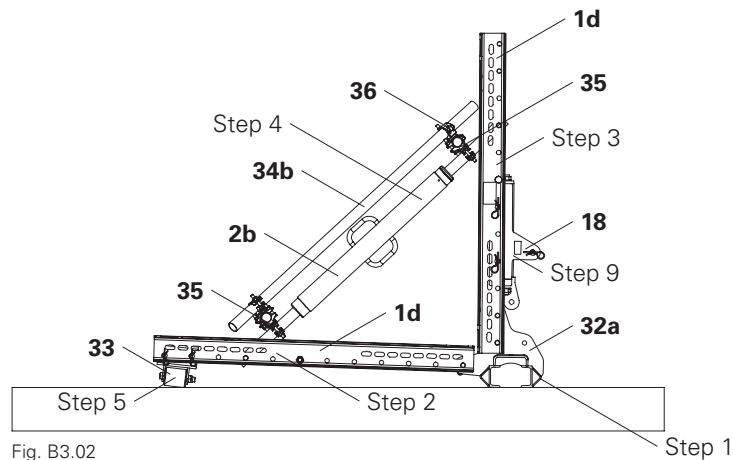

Fig. B3.02



For variant 1 (b2 = 1.00 m), the horizontally positioned scaffolding tubes can be secured in place with the Wall Tie UWT 140.

8. Adjust the position of the spacer in the vertical Steel Waler SRU U120 (1d) so that the Adjusting Unit VARIOKIT (18) can be installed if these collide (see Section A6)
9. Fit the Adjusting Unit VARIOKIT (18) onto the vertical Steel Waler SRU U120 (1d) using 2x fitting pins Ø 21 mm (26). (Fig. B3.02b)

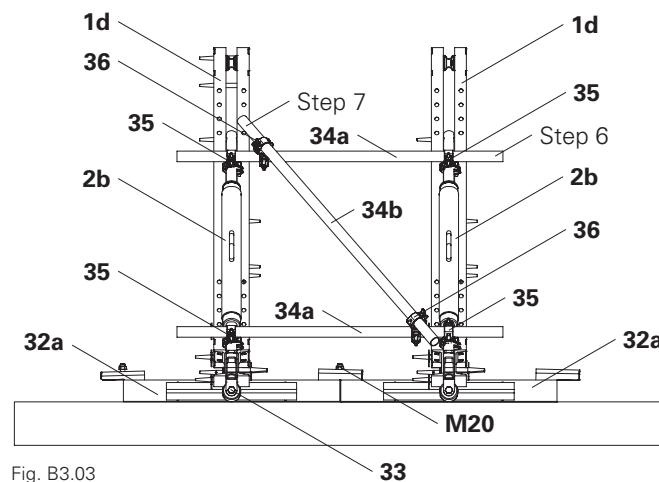

Fig. B3.03

# B4 Connecting the platform units

## Assembly of variant b2 = 100 cm

(b2 = 125/150 cm are analogous)

1. Connect element 1 and element 2 to the vertical Steel Waler SRU U120 (1d) and Connector SRU VARIOKIT (30) using 2x fitting pins Ø 21 mm (26). (Fig. B4.02a)
2. Pivot the Heavy-Duty Spindle SLS (2c) upwards and bolt it onto the horizontal Steel Waler SRU U120 (1d) using 1x fitting pin Ø 21 mm (26). (Fig. B4.01)
3. Bolt the Heavy-Duty Spindle SLS (2b) onto the Steel Waler SRU U120 (1f) using 1x fitting pin Ø 21 mm (26). (Fig. B4.02)
4. Bolt the horizontal Steel Waler SRU U120 (1e) onto the Adjusting Unit VARIOKIT (18) using 1x fitting pin Ø 21 mm (26).
5. Bolt the horizontal Steel Waler SRU U120 (1e) onto the Heavy-Duty Spindle SLS (2b) using 1x fitting pin Ø 21 mm (26).
6. Fit horizontal steel scaffolding tubes (34a) onto the threads of the Heavy-Duty Spindles SLS (2b) using Standard Couplers RA 48/48 (35) (top and bottom).
7. Attach diagonal steel scaffolding tube (34b) to the horizontal steel scaffolding tubes (34a) with swivel coupling AF 48/48 (36). (Fig. B4.02b)
8. Adjust the position of the spacer in the Steel Waler SRU U120 (1e) so that the Adjusting Unit VARIOKIT (18) can be installed if these collide. (see Section A6)

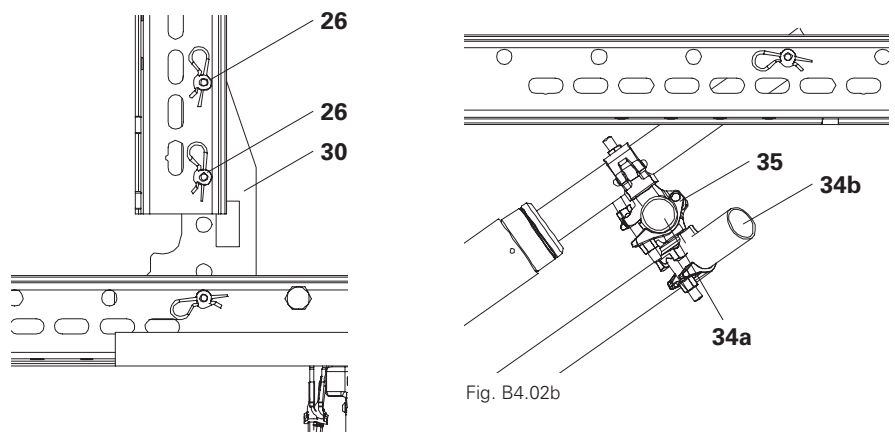
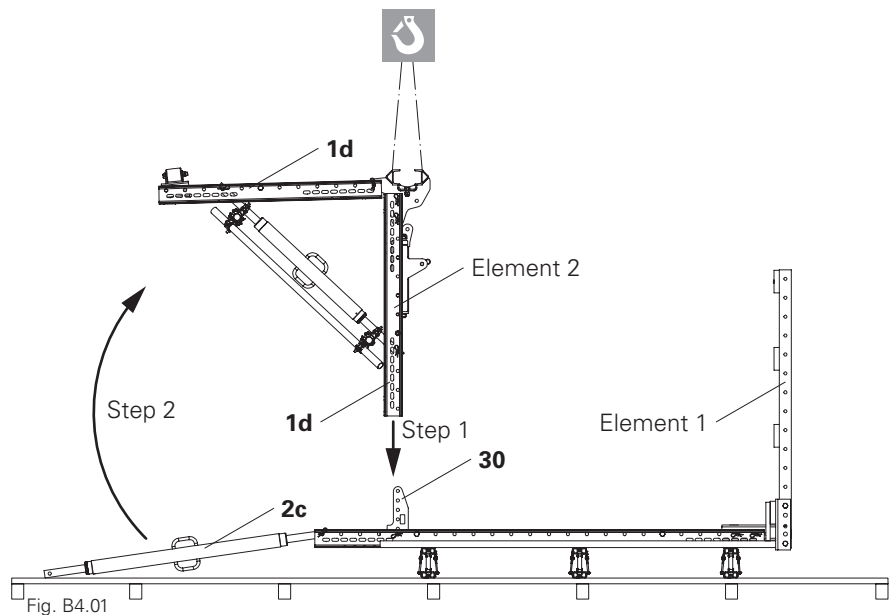

Fig. B4.02a

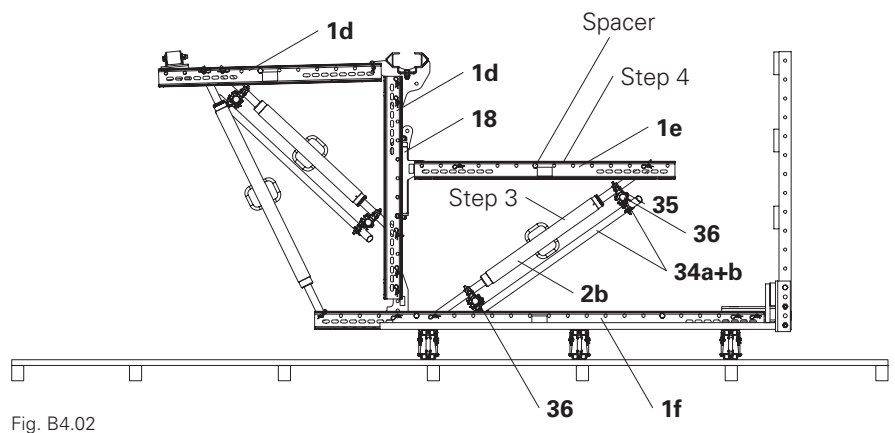

Fig. B4.02

## Leading platform

To assemble the roller units, the leading platform cantilevers outwards at the start. Thereby, the shoring remains the same as for the standard concreting units but without formwork support and with an enlarged platform.

### Guardrails

- Front-mounted guardrails with Guardrail Post SGP (38) and Guardrail Holder GT 24/VT 20 (39).
- Internal guardrails with Guardrail Post HSGP-2 (40) and Guardrail Holder SRU/SRZ (41) (each bolted 2x).
- External guardrails with Guardrail Post RCS/SRU (20) and Angle Connector RCS/SRU (19) (each bolted 2x).

### Travelling Nose 25-2

- Assemble the Rail Slide 25-2 VARIOKIT (42) on the first rail.

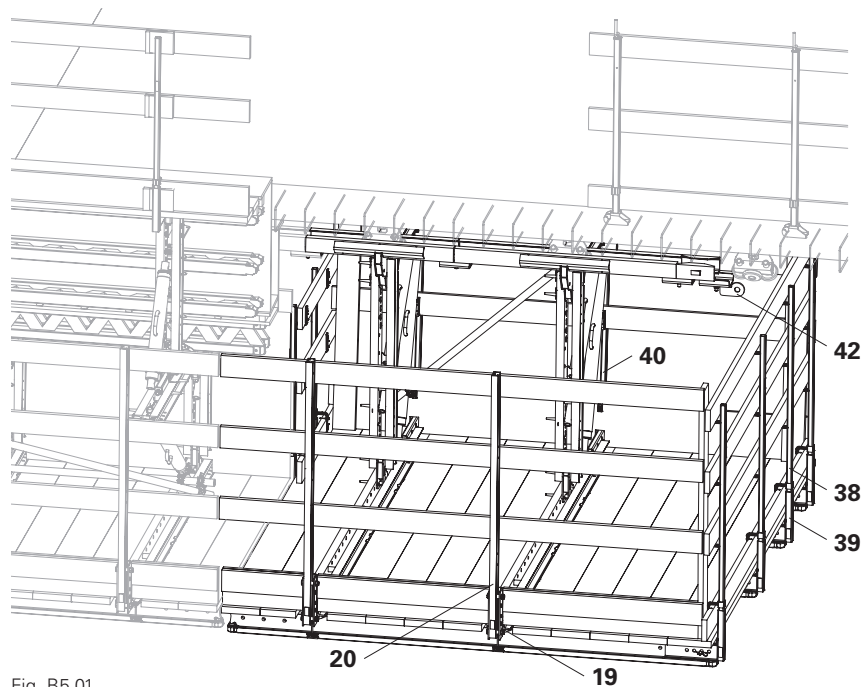

Fig. B5.01

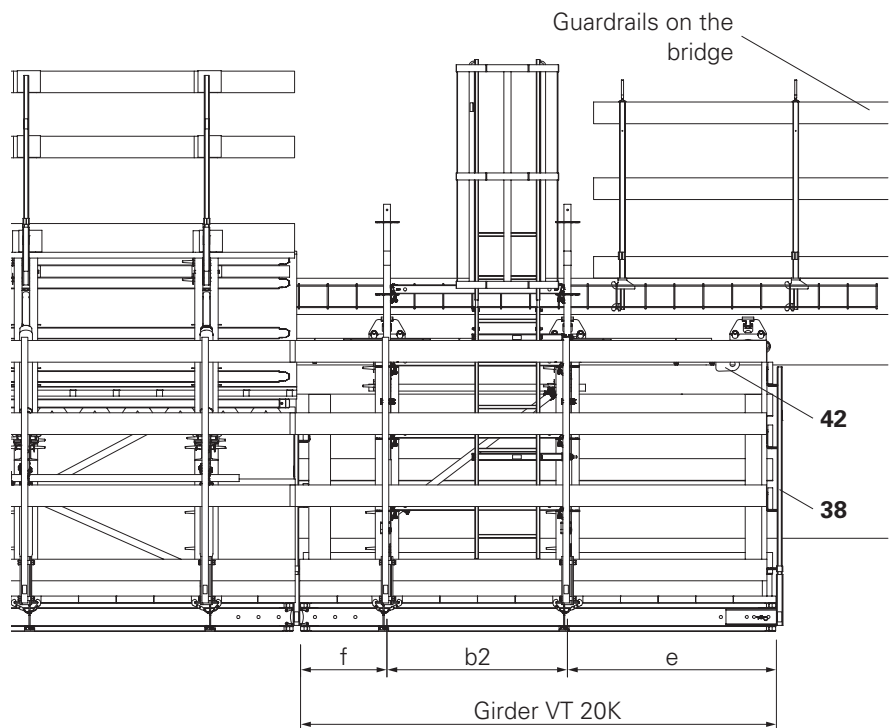

Fig. B5.02

### Leading and finishing platform dimensions (Fig. B5.02)

b2	1.00 m	1.25 m	1.50 m
e	1.40 m	1.45 m	1.70 m
f	0.50 m	0.60 m	0.70 m
<b>VT 20K</b>	<b>2.90 m</b>	<b>3.30 m</b>	<b>3.90 m</b>

Tab. B5.01

## Finishing platform

To dismantle the roller units, the finishing platform cantilevers outwards at the end. Thereby, the shoring remains the same as for the standard concreting units but without formwork support and with an enlarged platform.

### Guardrails

- Rear-mounted guardrails with Guardrail Post SGP (38) and Guardrail Holder GT 24/VT 20 (39)
- Internal guardrails with Guardrail Post HSGP-2 (40) and Guardrail Holder SRU/SRZ (41) (each bolted 2x).
- External guardrails with Guardrail Post RCS/SRU (20) and Angle Connector RCS/SRU (19) (each bolted 2x).



Closing the rail profile:  
The Rail Slide 25-2 VARIOKIT (42) must be mounted at the end of the Rail VARIOKIT using the bolt M24.

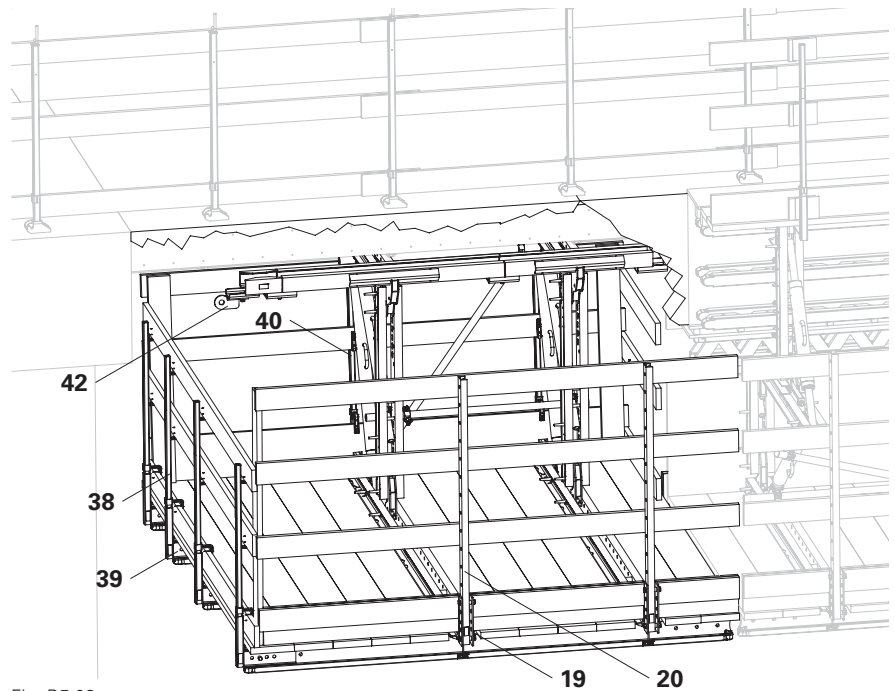

Fig. B5.03

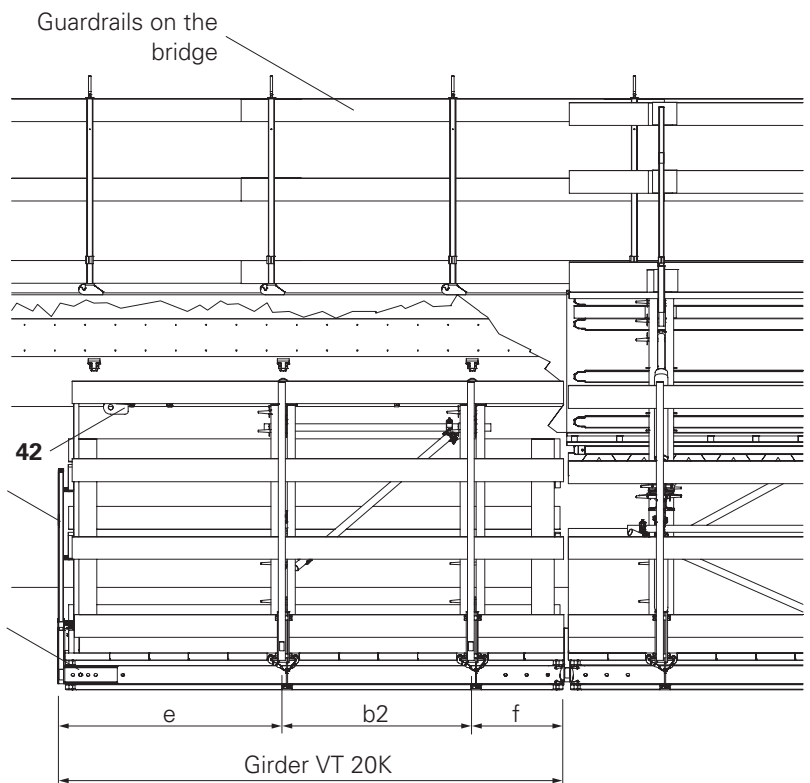

Fig. B5.04

## Assembling the guardrail holders

### Assembling on the steel girder:

1. Bolt Guardrail Holder SRU/SRZ (41) onto the Steel Girder SRU (1) with 2x bolts  $\varnothing 20 \times 140$  (41.1) and secure with cotter pin 4/1.
2. Insert Guardrail Post HSGP-2 (41) into Guardrail Holder SRU/SRZ (41).

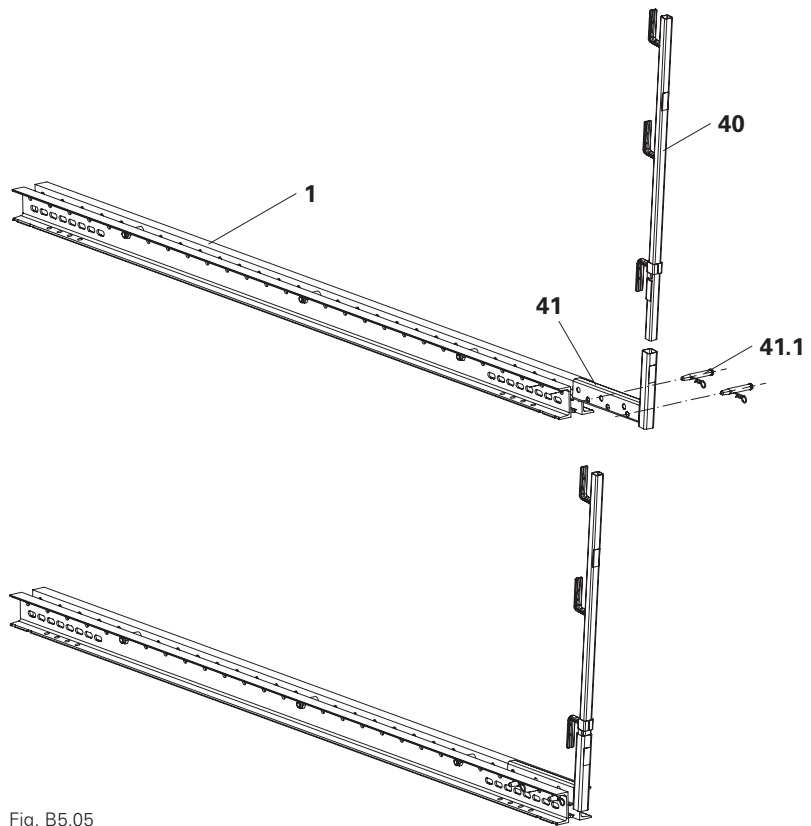

Fig. B5.05

### Assembling on Girder VT20K:

1. Bolt Guardrail Holder GT 24/VT 20 (39) onto the Girder VT20K (28) with 1x bolt  $\varnothing 20 \times 140$  (39.1) and secure with cotter pin 4/1.
2. Insert Guardrail Post SGP (38) into Guardrail Holder GT 24/VT 20 (39).

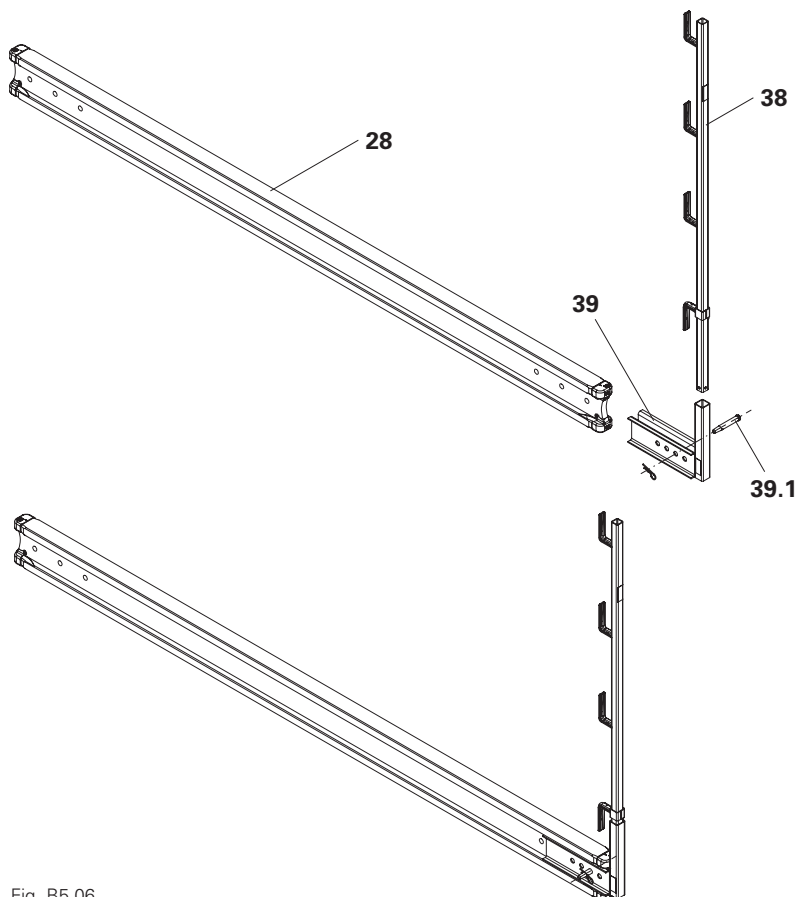

Fig. B5.06

## Assembly

1. Bolt column tie yoke (43) to Steel Waler SRU U120 (1f).
2. Fix Steel Waler SRU U120 (1e) to Steel Waler SRU U120 (1f) with column tie yoke (43) and Wingnut Pivot Plate DW 15 + secure with Nut DW 15. (Fig. B6.02a)
3. Insert Base Standard UVB (44) into the Top Standard UVH (48) and secure with Spindle Locking UJS (46).
4. Bolt Base Standard UVB (44) onto Steel Waler SRU U120 (1e) via Spindle Head SRU (46) using 2x fitting pins Ø 21 mm (26).
5. Bolt Scaffold Tube Connector FTF (47) onto Steel Waler SRU U120 (1d) using 2x fitting pins Ø 21 mm (26) each time.
6. Attach 1x horizontal steel scaffolding tube (34a) to Scaffold Tube Connector FTF (47) and Top Standard UVH (48) with swivel couplings AF 48/48 (36).
7. Attach steel scaffolding tube (34) to the horizontal steel scaffolding tubes (34a) with swivel coupling AF 48/48 (36).
8. Fit Horizontal Ledger UH (54) between the two Top Standards UVH (48) and Base Standards UVB (44).
9. Fix Ladder Connector UAC-2 (49) to Top Standards UVH (48) and Base Standard UVB (44).
10. Assemble Ladder 180/6 (50), Access Ladder 180/2 (51) and Ladder Base (52).
11. Attach Ladder Safety Cage 150 (53) to Access Ladder 180/2 (51).
12. Fix ladder with ladder safety cage to Ladder Connector UAC-2 (49).
13. Bolt ladder base (52) to planking.

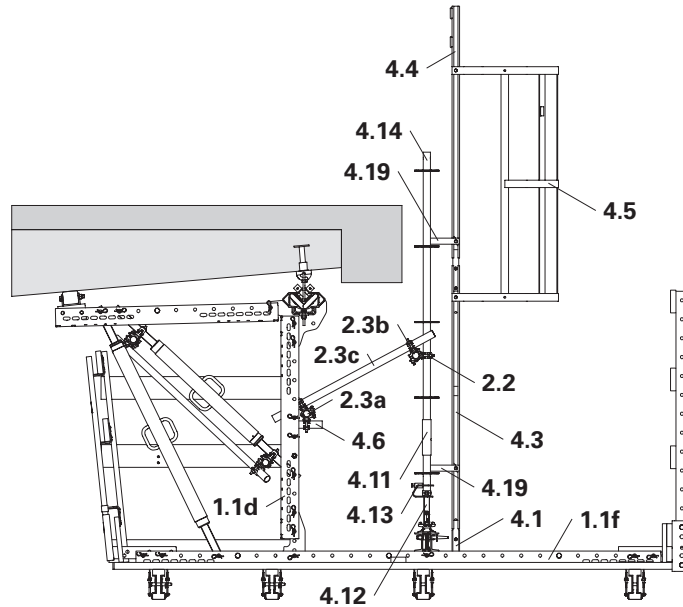

Fig. B6.01

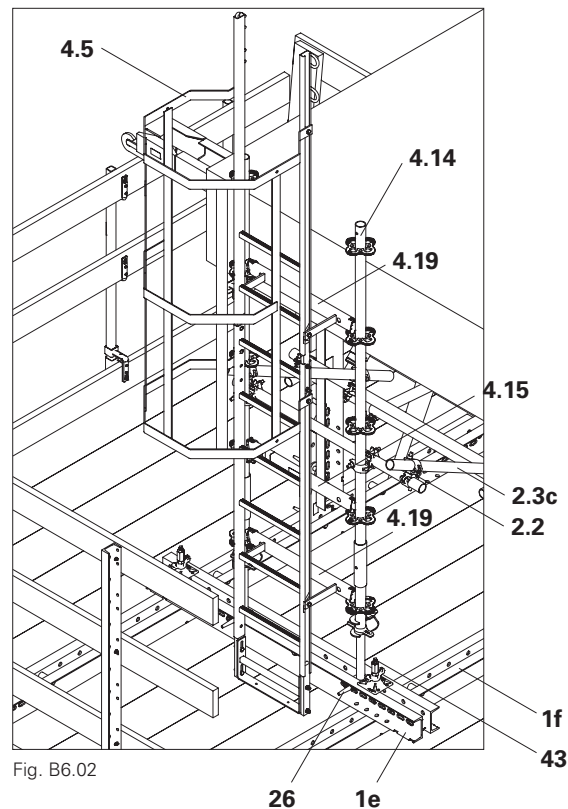

Fig. B6.02

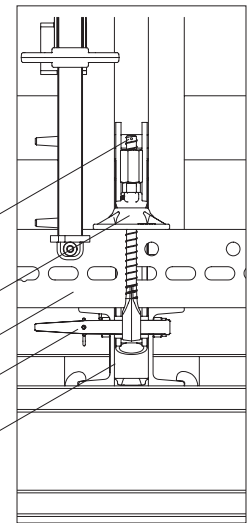

Fig. B6.02a

## Pre-assembly of ladder

1. Lay out Access Ladder 180/2 (**51**), Ladder 180/6 (**50**) and the Ladder Base (**52**).
2. Connect Access Ladder 180/2 (**51**) to Ladder 180/6 (**50**) using bolts M12x40, AF 19.
3. Fix Ladder Base (**52**) to Ladder 180/6 (**50**) using bolts M12x40 AF 19. (Fig. B6.03)

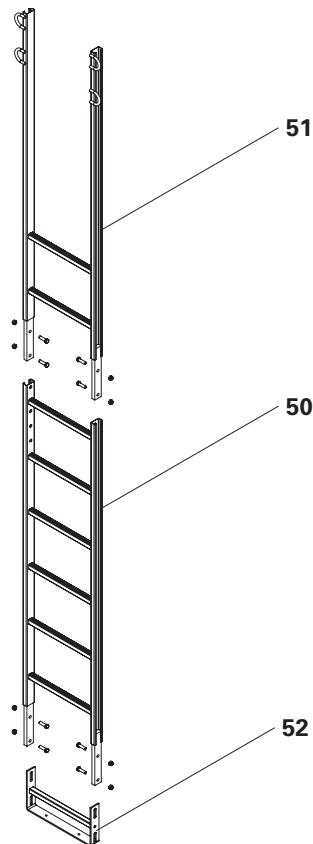

Fig. B6.03

## Mounting the ladder base

1. To fit the ladder horizontally, screw the drawn-out bracket of the ladder base to the planking tightly with 3x Torx TSS 6x40. (Fig. B6.03)

## Mounting the ladder cage

1. Move the Ladder Safety Cage 150 (**53**) into position using a rope and hold it there.
2. Slightly loosen bolts M12x25 on the clamping plates, position clamping plates on the ladder longitudinal members, and tighten screws. (Fig. B6.04a)

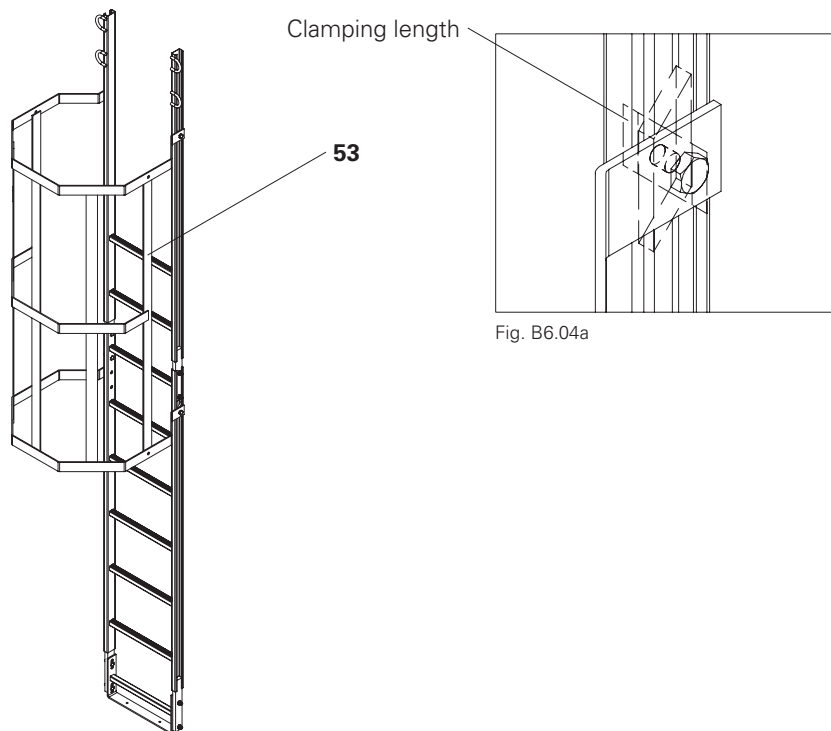

Fig. B6.04a

Fig. B6.04



## Roller unit



Ensure that the Suspension Head M24 VARIOKIT (14) is correctly assembled. The hook pockets of the Suspension Head M24 VARIOKIT (14) should always point alternately towards the outer edge and inner edge of the cantilever. (Fig. B7.01)

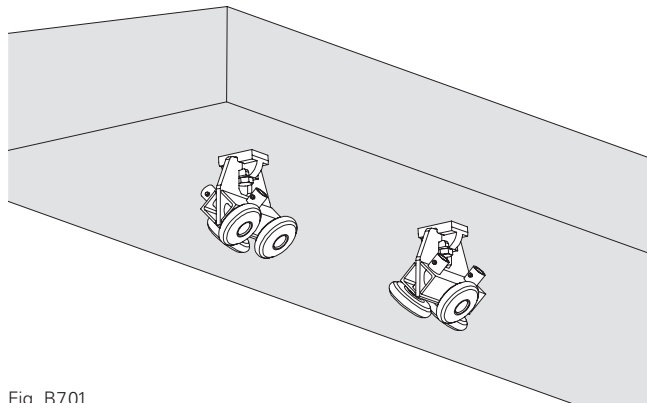

Fig. B7.01

### Assembling the roller units

1. Push the Roller Unit VARIOKIT (7) into the Suspension Anchor M24 VARIOKIT (14) sideways. (Fig. B7.01a)
2. Swivel the Roller Unit VARIOKIT (7) downwards.



The Roller Unit VARIOKIT (7) pivots into the vertical end position as a result of gravity. (Fig. B7.01b)

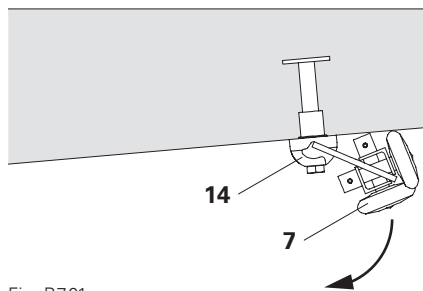

Fig. B7.01a



For parapets with large projections, we recommend mounting the Suspension Anchor M24 VARIOKIT with the opening to the bridge superstructure to make it easier to dismantle the roller units. (see Section A4)

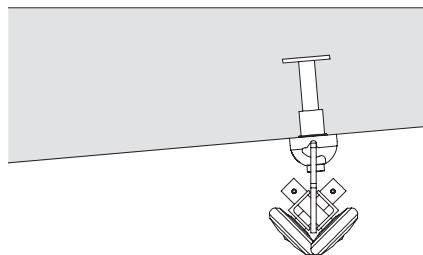

Fig. B7.01b

## Preparing the auxiliary construction

For lifting the platform units in or out, an auxiliary construction must be mounted on the platforms.

The following additional material is required:

Pos. no.	Designation	Quantity	Article no.
<b>26</b>	Fitting Pin Ø 21 x 120	12	104031
<b>27</b>	Cotter pin 4/1	12	018060
<b>55</b>	Cross Connector VARIOKIT	6	111279
<b>1g</b>	Steel Waler Universal SRU U120, L = 2.72 m	3	103929
<b>56</b>	Spacer for Platform Beam BR	4	020620
<b>57</b>	Lifting Eye BR-2 2.5 t	4	127834

Tab. B7.01



The auxiliary construction must be statically verified for each project.

## Assembling the auxiliary construction with leading and finishing platforms



For ballasting purposes, a third Steel Waler Universal SRU U120 must be mounted as a storage surface (Fig. B7.03)

### Assembly

1. Mount 6x Cross Connectors VARIOKIT (55) using 1x fitting pin  $\text{Ø} 21 \times 120$  (26) respectively in the Steel Waler Universal SRU U120 of the leading/finishing platforms and secure with cotter pins 4/1 (27).
2. Mount 3x Steel Waler Universal SRU U120 (1g) with 1x fitting pin  $\text{Ø} 21 \times 120$  (26) respectively per Cross Connector VARIOKIT (55) and secure with cotter pins 4/1 (27).

(Fig. B7.02)

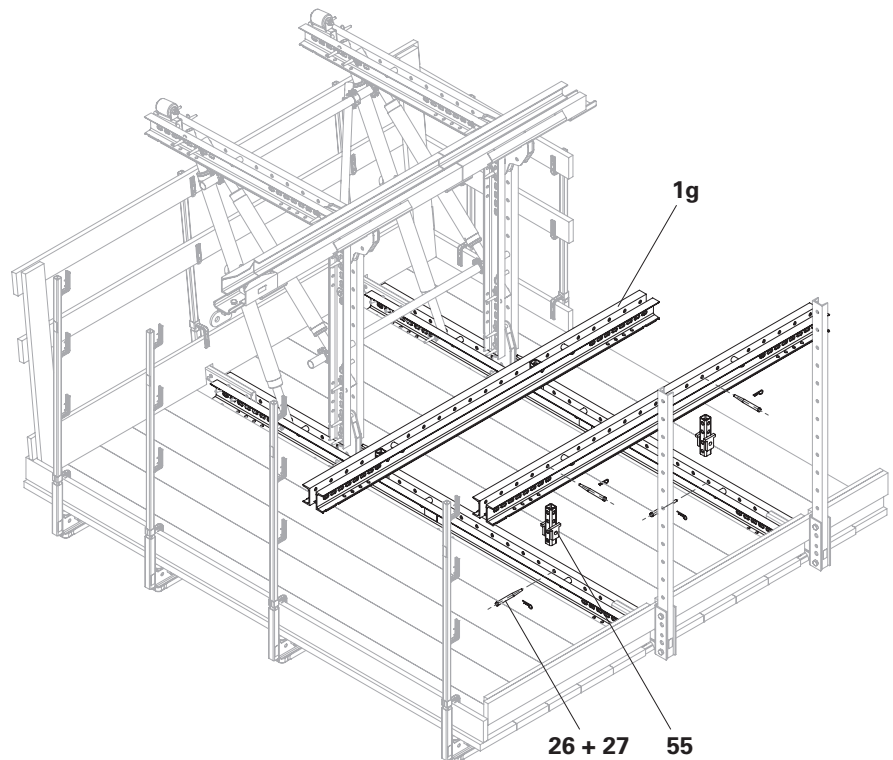

Fig. B7.02

### Assembling the lifting eye (4x)

3. Insert the sleeve (56.1) of the spacer for the Platform Beam BR (56) through the Lifting Eye BR-2 2.5 t (57).
4. Slide the Lifting Eye BR-2 2.5 t (57) and sleeve into the Steel Waler Universal SRU U120 (1g) and secure with the bolt (56.2) and nut (56.3).

(Fig. B7.03)

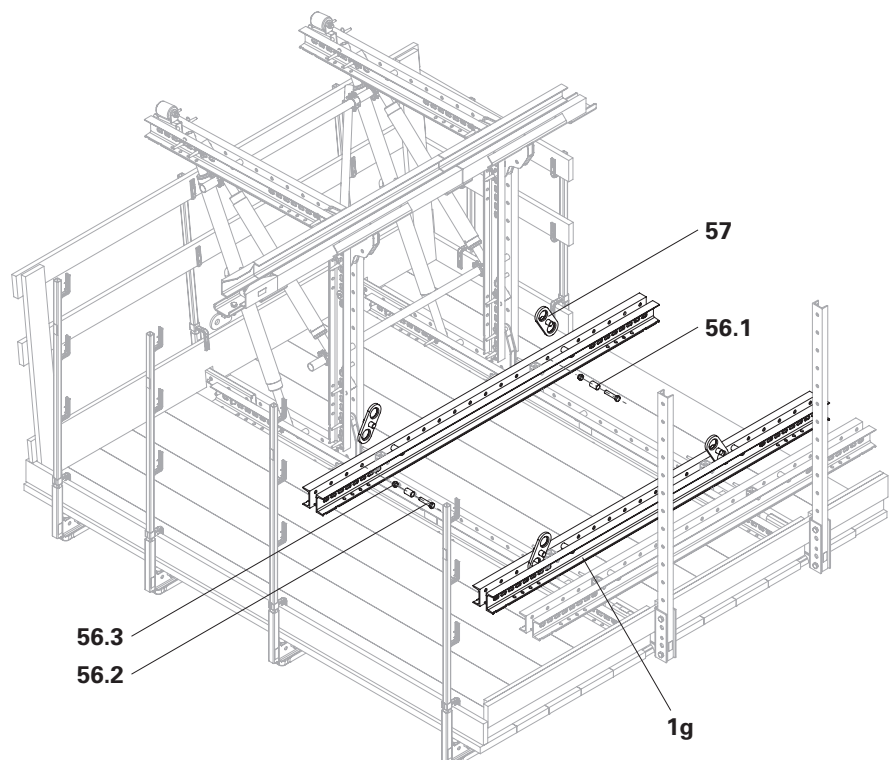

Fig. B7.03

## Assembling the auxiliary construction with standard platforms

### Assembly

1. Mount 4x Cross Connectors VARIOKIT (55) using 1x fitting pin  $\varnothing$  21 x 120 (26) respectively in the Steel Waler Universal SRU U120 of the platform support and secure with cotter pins 4/1 (27).
  2. Mount 2x Steel Waler Universal SRU U120 (1g) with 1x fitting pin  $\varnothing$  21 x 120 (26) respectively per Cross Connector VARIOKIT (55) and secure with cotter pins 4/1 (27).
- (Fig. B7.04)

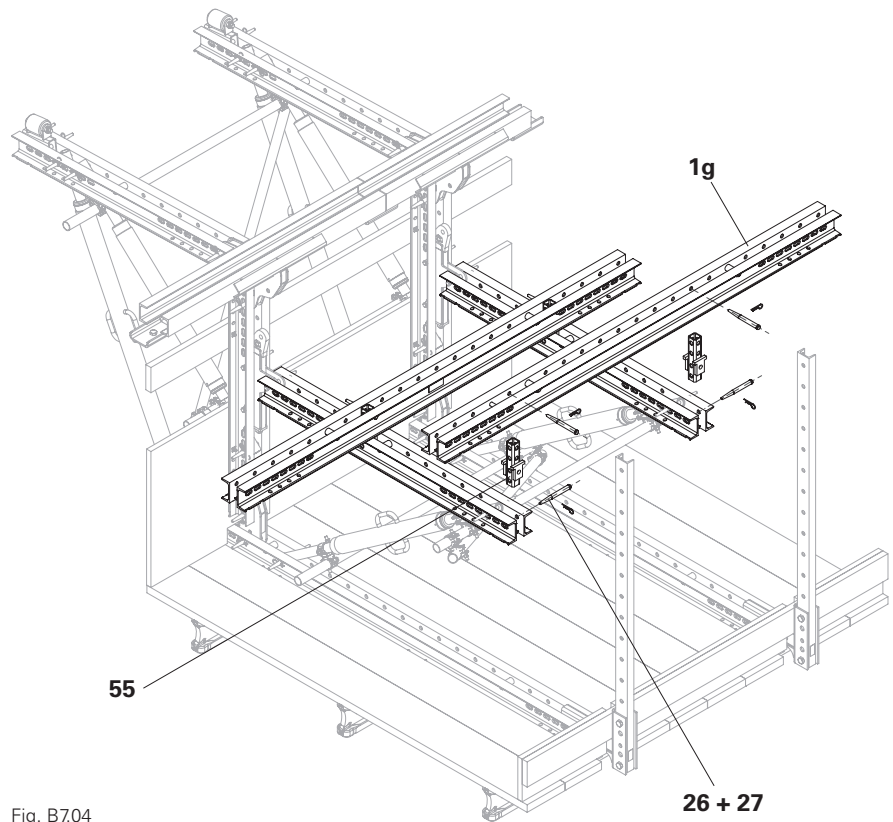

Fig. B7.04

### Assembling the lifting eye (4x)

3. Insert the sleeve (56.1) of the spacer for the Platform Beam BR (56) through the Lifting Eye BR-2 2.5 t (57).
  4. Slide the Lifting Eye BR-2 2.5 t (57) and sleeve into the Steel Waler Universal SRU U120 (1g) and secure with the bolt (56.2) and nut (56.3).
- (Fig. B7.05)

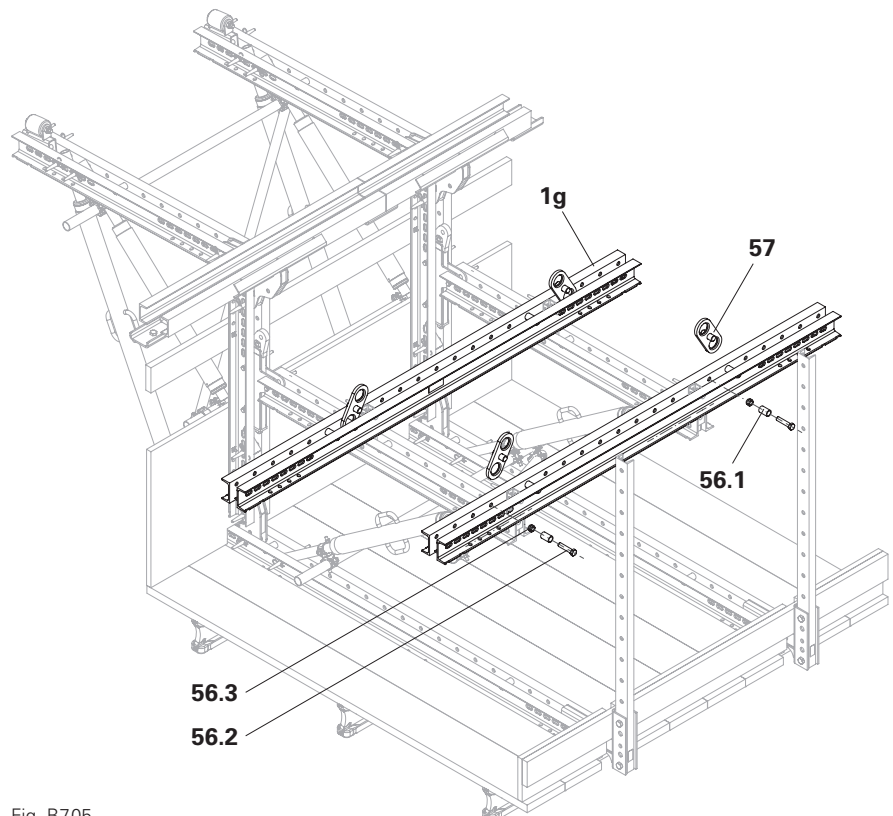

Fig. B7.05



- Depending on the size of the platform, place the steel walers in an offset position as the spacers may collide with the Cross Connectors VARIOKIT.
- In terms of the arrangement, ensure that the weight is evenly distributed. (Fig. B7.08 + B7.08a)

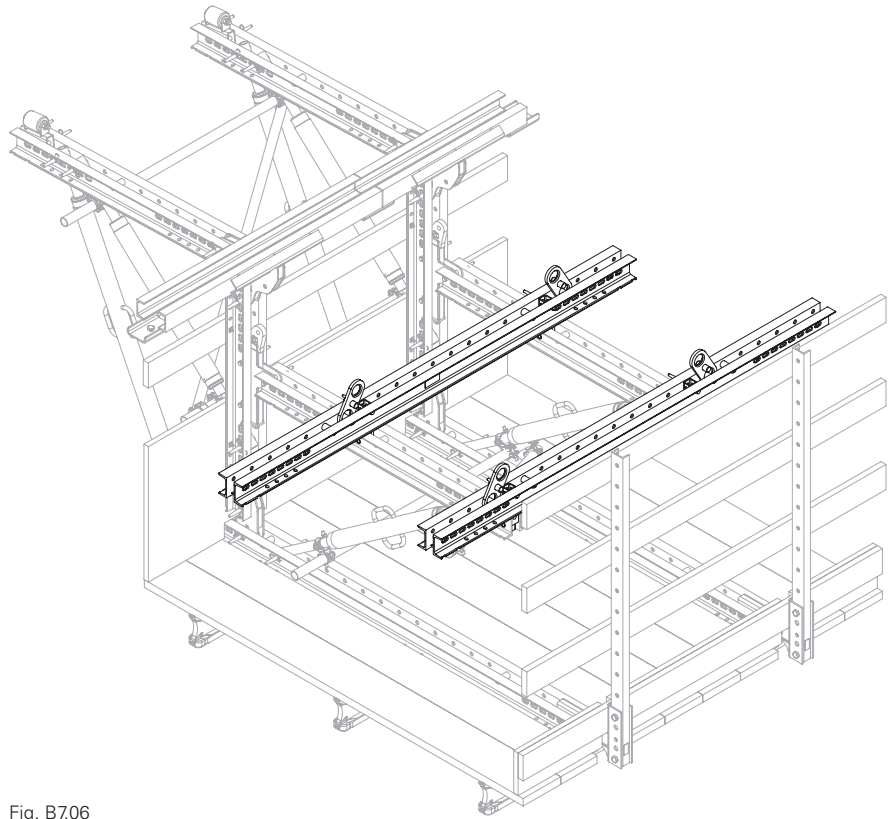

Fig. B7.06

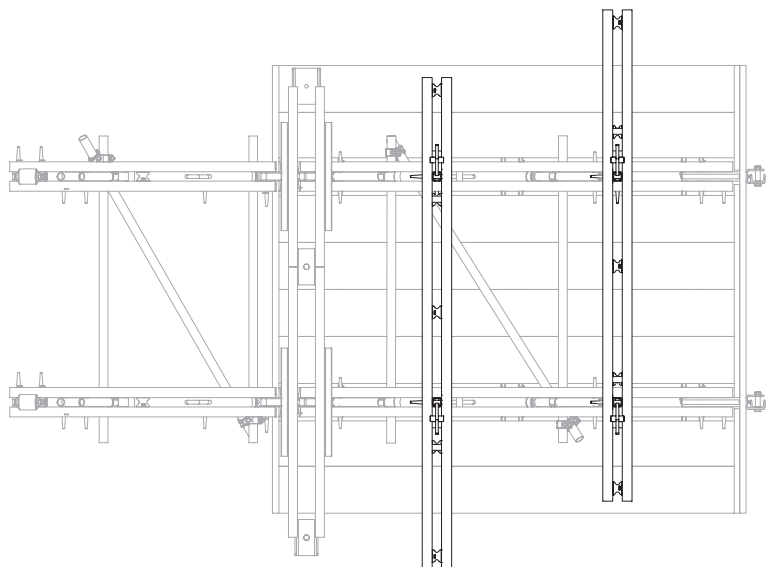

Fig. B7.06a

## Attachment points for crane lifting gear



- Determine the ballast and its position on site by means of tests and ensure it is immovably secure (e.g. with tension belts).
- Do not place the ballast directly on the platform decking.
- Project-specific static proof for the auxiliary construction required.



- Pay attention to the actual platform weight.
- Take the max. crane sling angle into consideration.
- Use appropriate 4-sling lifting gear.
- The lifting equipment must have sufficient load-bearing capacity.
- 

### Attachment

1. Attach crane lifting gear to the Lifting Eyes BR-2 2.5 t (57). (Fig. B7.0)

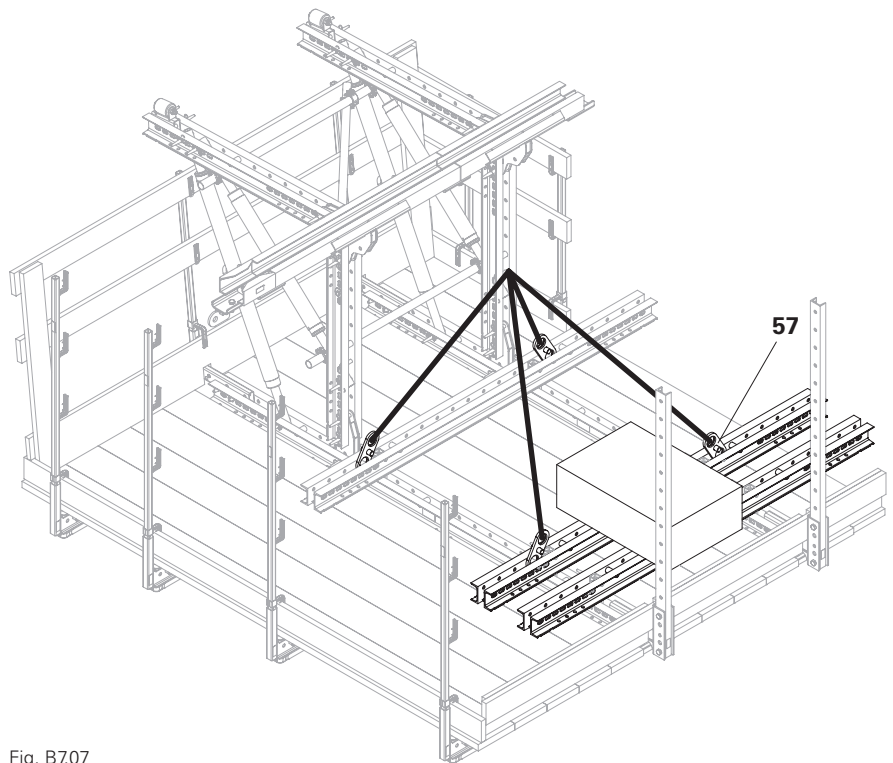

Fig. B7.07

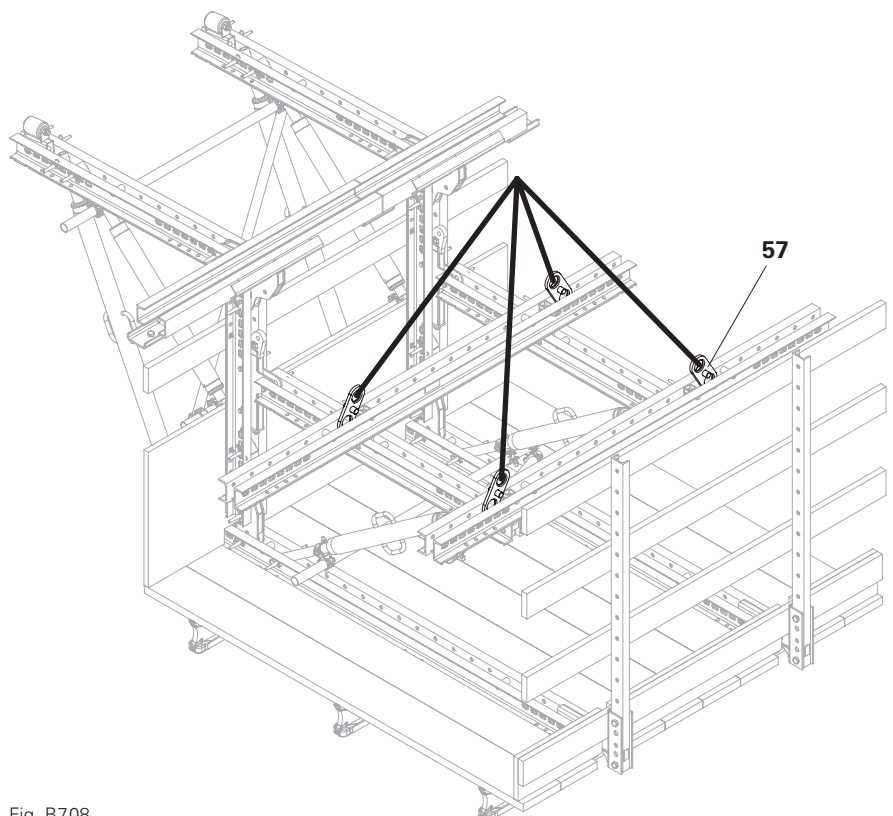

Fig. B7.08

## Attachment points for PPE



Attach PPE to the spacers in the vertical Steel Walers Universal SRU, U120 (1).

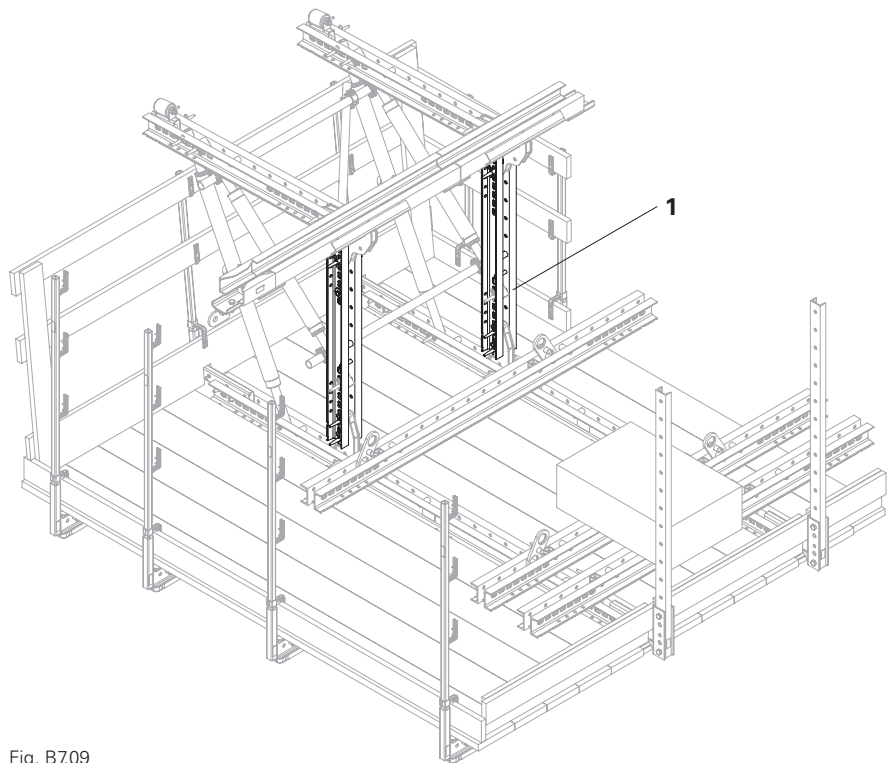

Fig. B7.09

## Lifting procedure: outer parapet



Mount the platforms from a safe working position.

### Attaching

1. The individual units are pushed along the rails (32a) and (32b) laterally on the roller units (7).



If necessary, guide the unit by means of a rope.

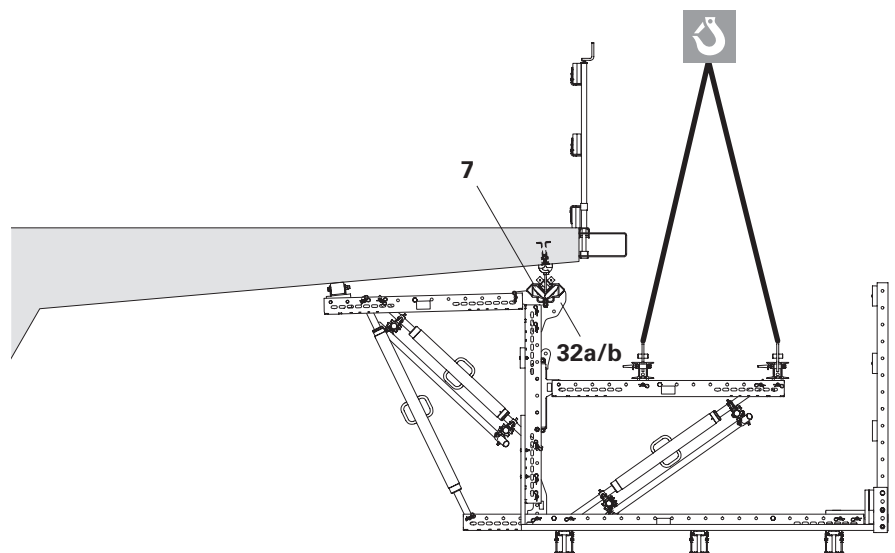

Fig. B7.10

## Connecting the individual platforms

The individual segments are connected using Rails 100 (**32a**) and 150 (**32b**).

### Platform connection

1. Push connection plates into each other. (Fig. B7.07a)
2. Screw the connection plates together using bolts M20 x 45. (Fig. B7.11 + B7.11a)

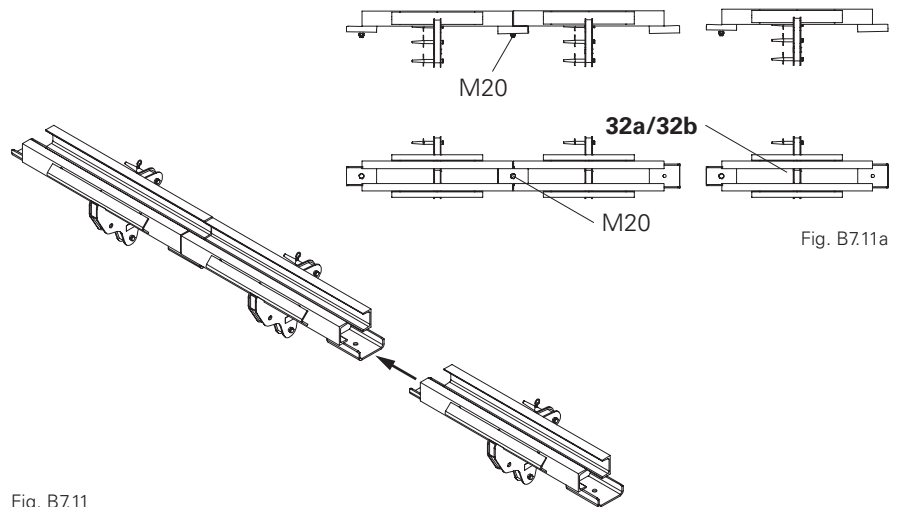

Fig. B7.11



- With a longitudinal inclination, secure the platform units in the various suspension positions in order to prevent any horizontal movement.
- Guardrails remain fitted until the finishing platform has been installed. Use PPE.
- Move the platform units away accordingly during the attachment procedure.



The Work Cage GKB can be used for attaching the roller units.

### Installation procedure step 1

1. Roller Units VARIOKIT (**3.7**) are positioned at tie points 5, 6 and 7. → Leave tie points 1, 2, 3, 4 free for the attachment procedure.
2. Mount the leading platform on the roller units (**3.7**) 5 and 6.

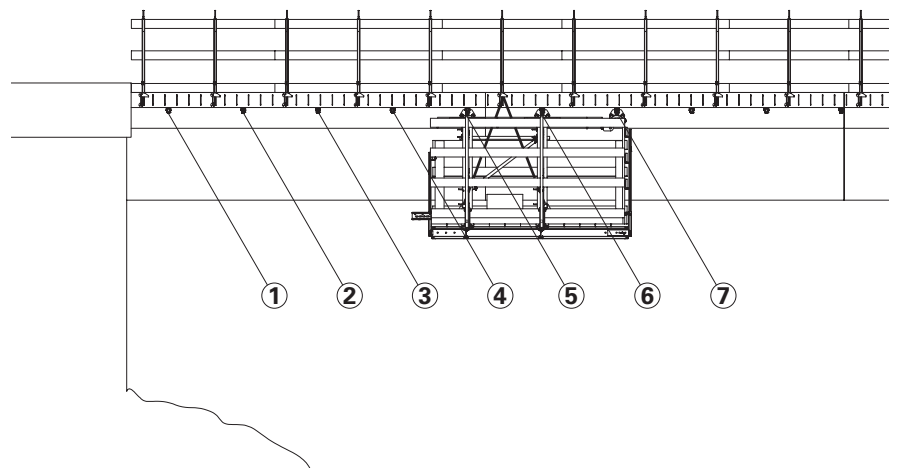

Fig. B7.12

### Installation procedure step 2

1. Roller Units VARIOKIT are positioned at tie points 3 and 4.
2. Mount the standard concreting unit on Roller Units VARIOKIT 3 and 4.
3. Connect standard concreting unit to the leading platform using bolts M20 x 45.

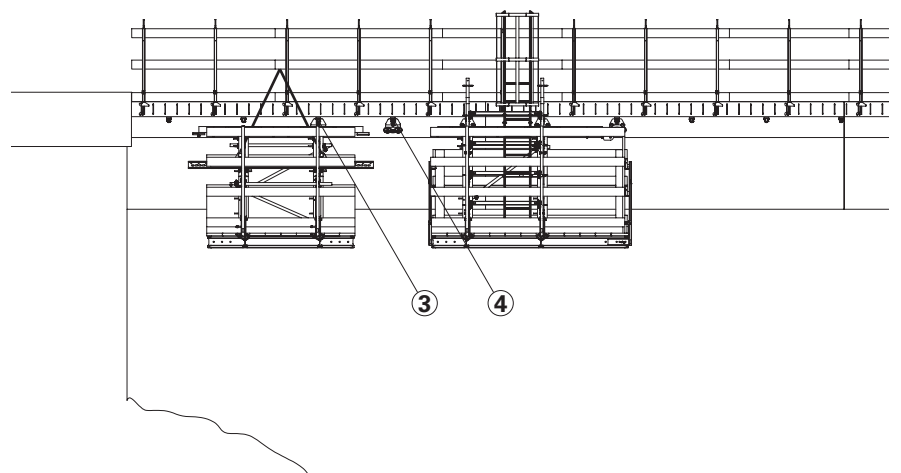

Fig. B7.13



### Installation procedure step 3

1. Roller Units VARIOKIT are positioned at tie points 8 and 9.
2. Pull coupled units on roller units 5, 6, 7 and 8.
  - Roller units 3 and 4 are free.

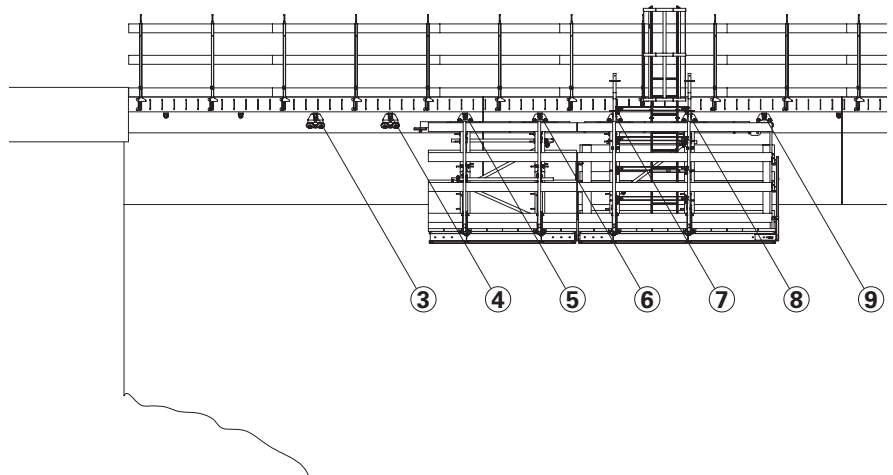

Fig. B7.14

### Installation procedure step 4

1. Mount the standard concreting unit on Roller Units VARIOKIT 3 and 4.
2. Connect standard concreting unit and coupled units using bolts M20 x 45.
  - Repeat steps 3 and 4 until all standard concreting units have been mounted.
  - In the process, Roller Units VARIOKIT can be successively mounted on the Anchor Sleeves M24 (3.1) from the leading platform, from tie point 10 onwards.

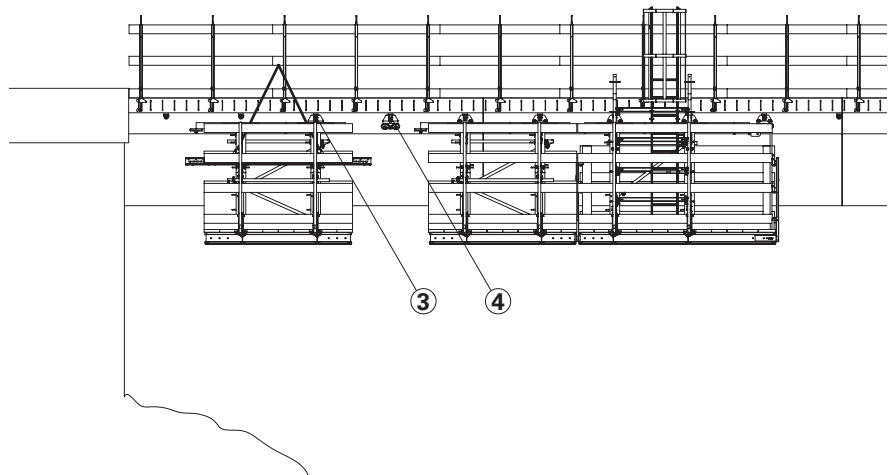

Fig. B7.15

### Installation procedure step 5

1. Roller Units VARIOKIT are positioned at tie points 1 and 2.

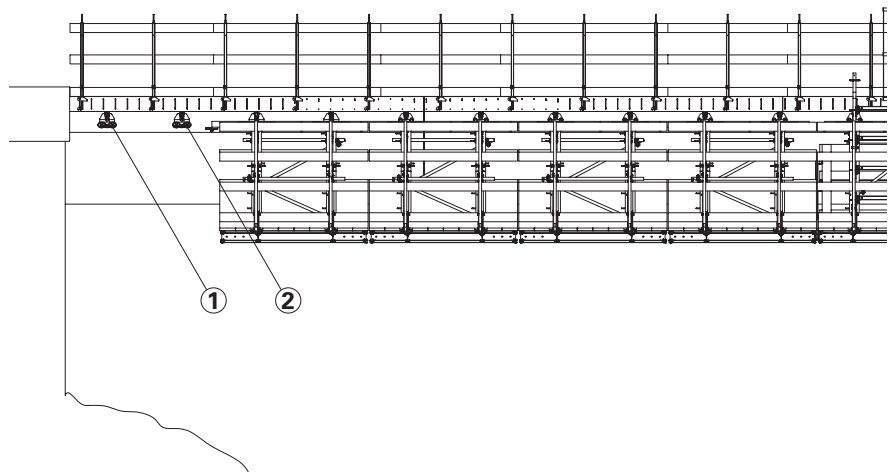

Fig. B7.16

## Installation procedure step 6

1. Retract track up to the abutment.
2. Install parapet formwork.  
(see Sections C3 and C4)
3. Concrete the first parapet section.  
(see Section C5)

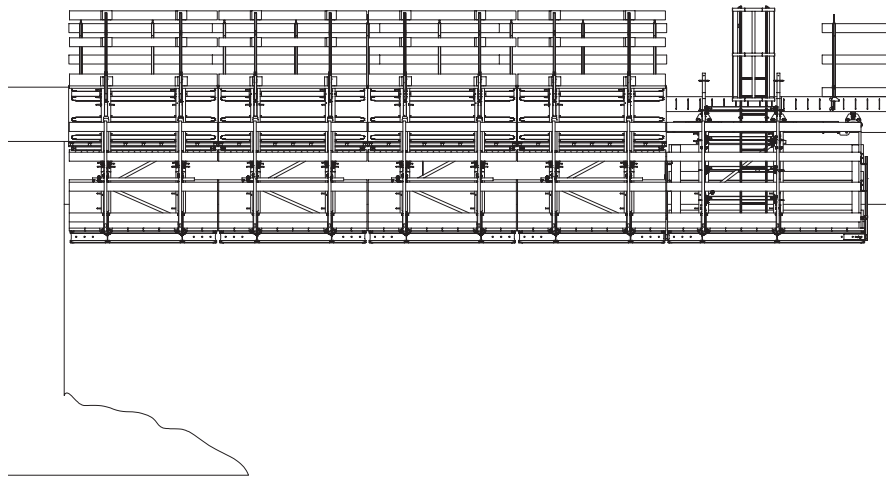

Fig. B7.17

## Installation procedure step 7

1. Pull VGB Parapet Track forward until tie points 1, 2, 3, 4, 5 and 6 are free.
2. In the process, remove Roller Units VARIOKIT from tie points 1, 2, 3 and 4.
3. Mount the finishing platform on Roller Units VARIOKIT 5 and 6.
4. Connect the finishing platform and coupled units using bolts M20 x 45.

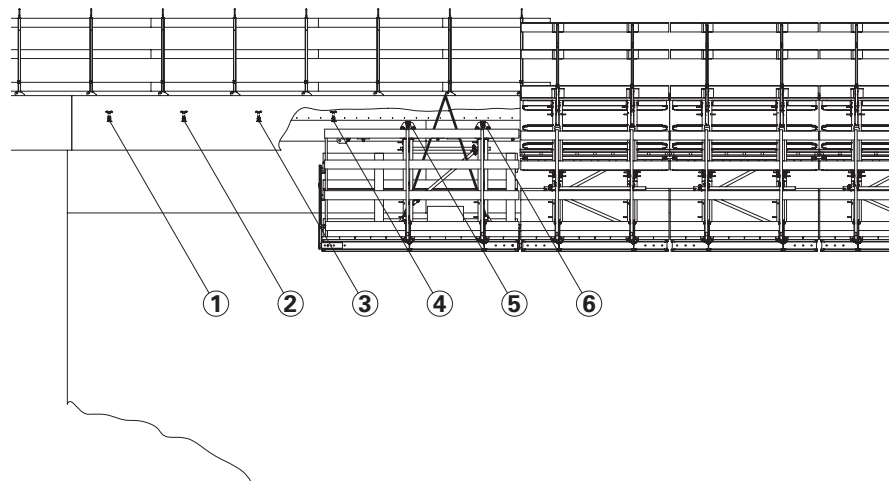

Fig. B7.18

## Standard operating procedure

1. Pull the VGB Parapet Track to the next cap section.
2. Shutter the parapet. (see Sections C3 and C4)
3. Install reinforcement.
4. Concreting. (see Section C5)
5. Strike the parapet. (see Sections C6 and C7)
6. Begin the relocation procedure. (see Section C8)
7. During the relocation procedure, mount guardrails on the cantilevered parapet successively. (see Section A7)

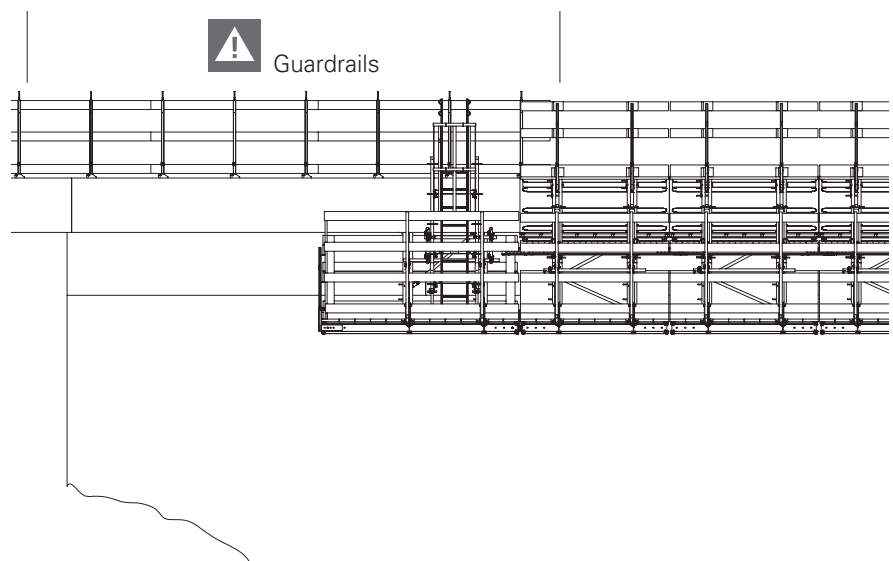

Fig. B7.19

## Last concreting cycle

### Last concreting cycle step 1

1. Lift out the leading platform 4 tie points before the end of the bridge. To do this, mount the auxiliary construction on the leading platform, position the ballast and attach crane.
2. Release the connection to the control unit, leave the leading platform and then lift the platform.

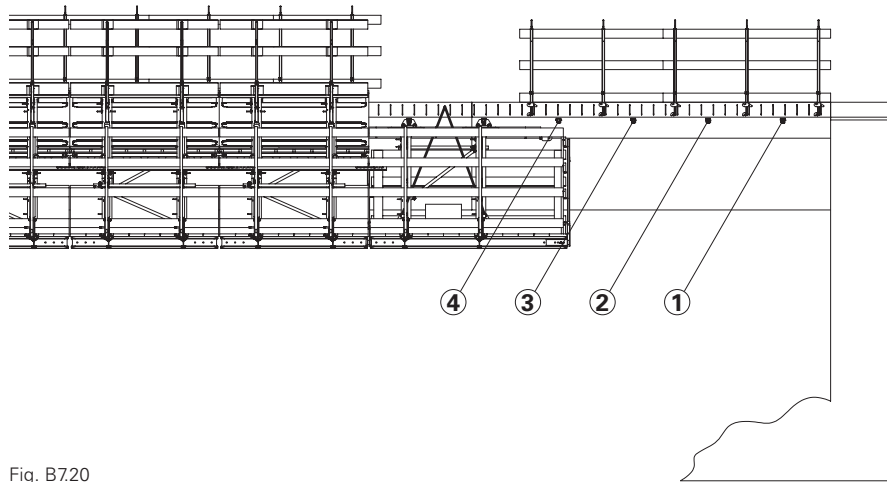

Fig. B720

### Last concreting cycle step 2

1. Pull the track up to the abutment and concrete the last cycle. Remove formwork elements.

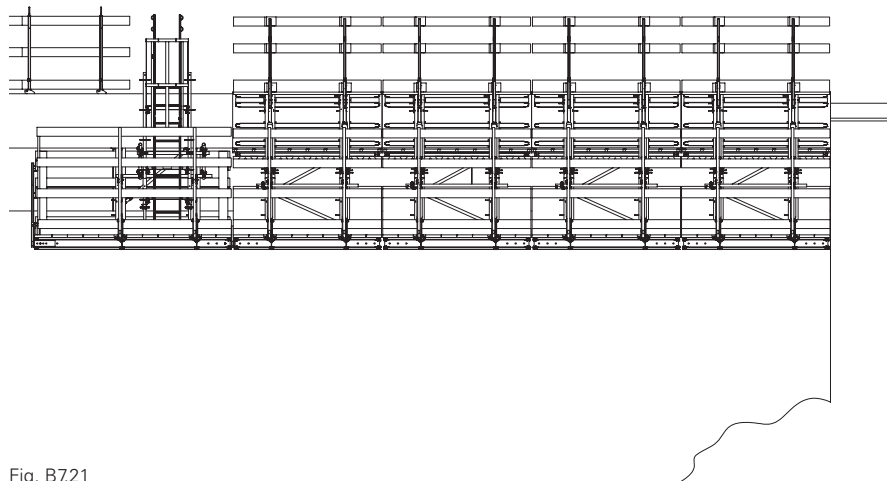

Fig. B721

## Lifting out procedure

### Lifting out procedure step 1

1. Retract the track and remove the roller units at the first two tie points.

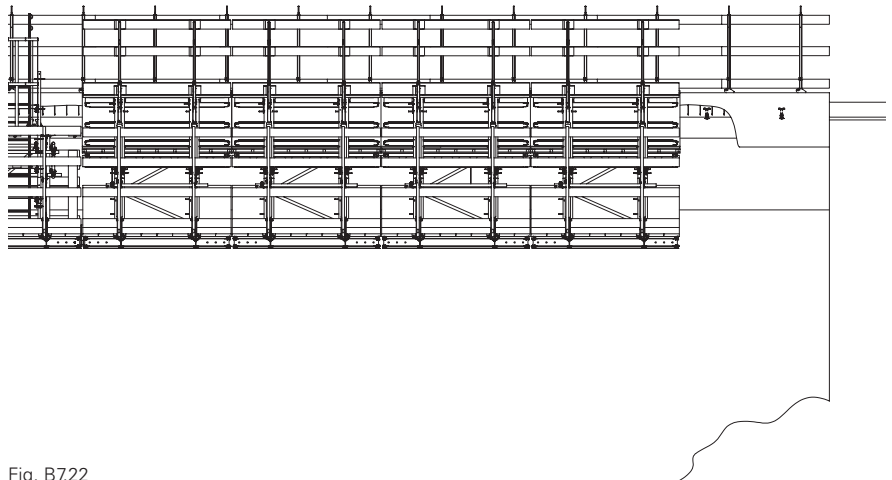

Fig. B722

### Lifting out procedure step 2

1. Mount the auxiliary construction, position the ballast and attach the crane.
2. Release the connection to the other control unit, leave the platform and then lift the platform.

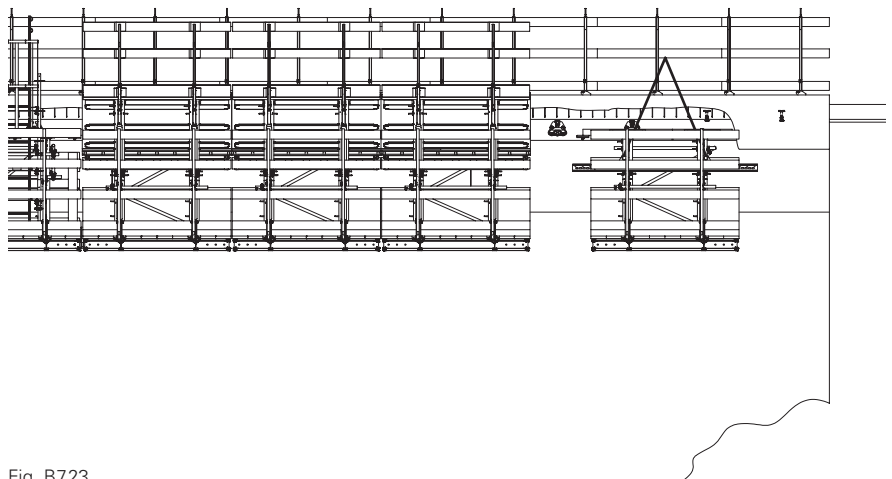

Fig. B723

### Lifting out procedure step 3

1. After lifting out the last control unit, also lift out the finishing platform in the same way as the leading platform.

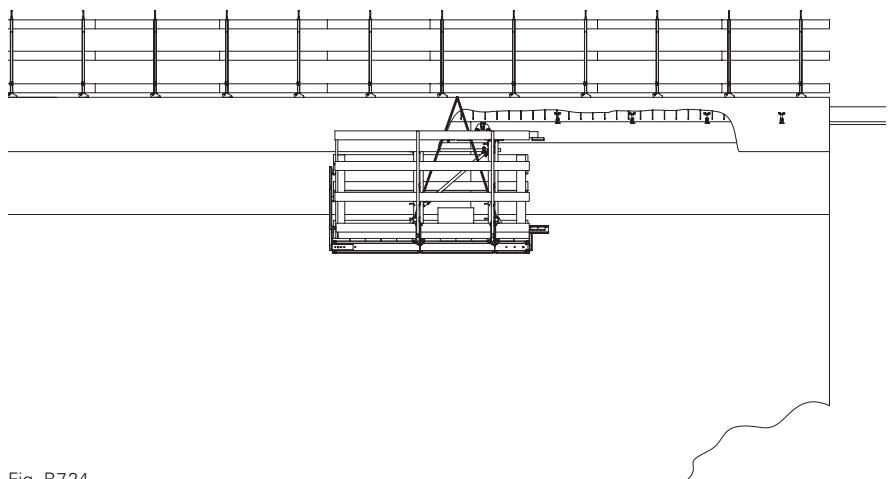

Fig. B724

## Lifting procedure: middle parapet



- The centre of gravity of the platforms, as well as the required ballast and position of the load-bearing points, are determined according to the individual project.
- When lifted, the platform must be balanced.
- As leading edges could be created during the lifting in and out processes, PPE must be used.

### Platform unit

1. Attach 4-sling lifting gear to the Lifting Eyes BR-2 2.5 t (57)
2. Lift platform and mount on Roller Units VARIOKIT (7).

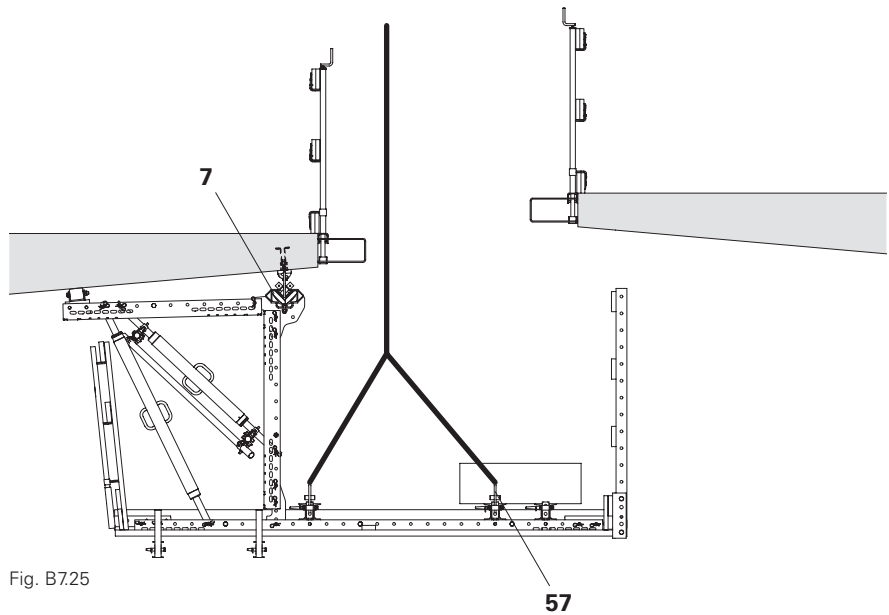

Fig. B.725

- The attachment procedure is the same as for the outer parapet (see Section B7).
- Assembly takes place, for example, with the help of a work platform.

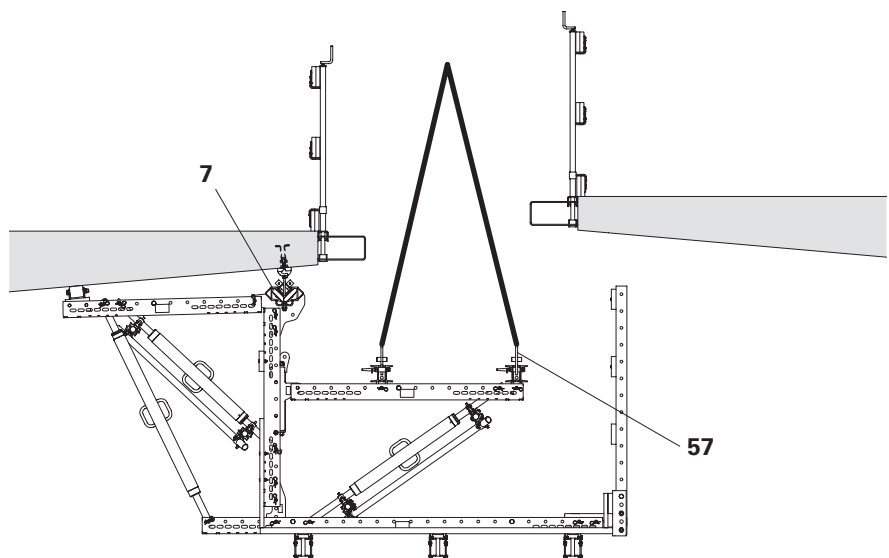

Fig. B.726

## Internal formwork

### Assembly

1. Bolt Adjusting Unit VARIOKIT (18) onto the Steel Waler SRU U120 (1e) using 2x fitting pins Ø 21 mm (26).
2. Insert pre-assembled slab formwork B into the Steel Waler SRU U120 (1e).
3. Bolt the slab formwork B onto the Adjusting Unit VARIOKIT (18) and Steel Waler SRU U120 (1e) using 2x fitting pins Ø 21 mm (26).

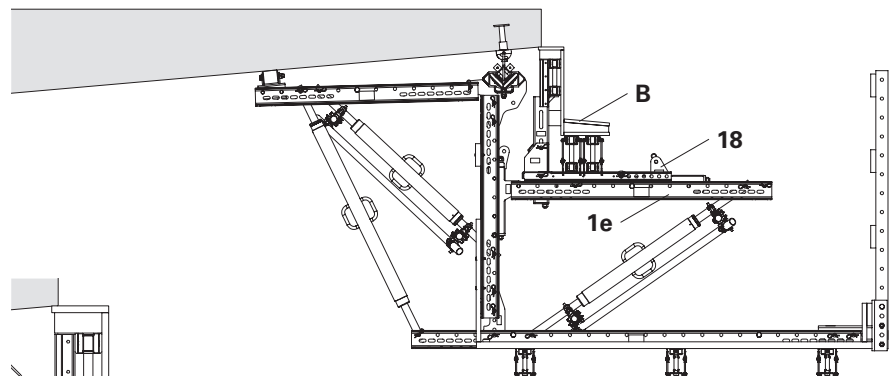

Fig. B8.01

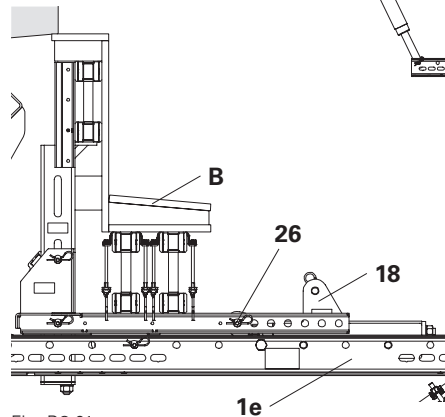

Fig. B8.01a

## External formwork



Ensure there is sufficient overlap length on the decking and handrail boards to prevent any tipping.

### Assembly

1. Bolt Platform Beam SRU (58) onto the Steel Waler SRU U120 (1c) of the pre-assembled external formwork element A using 2x fitting pins Ø 21 mm (26).
2. Insert Guardrail Post HSGP-2 (40) into the Platform Beam SRU (58).
3. Attach handrail boards and platform decking, and fix using screws.
4. Bolt the formwork unit with platform beam onto the Adjusting Unit VARIOKIT (18) using 1x fitting pin Ø 21 mm (26). (Fig. B8.02a)
5. Bolt the Heavy-Duty Spindle SLS (2a) between the Steel Waler SRU U120 (1c) and Steel Waler SRU U120 (1e) using 2x fitting pins Ø 21 mm (26). (Fig. B8.02b)

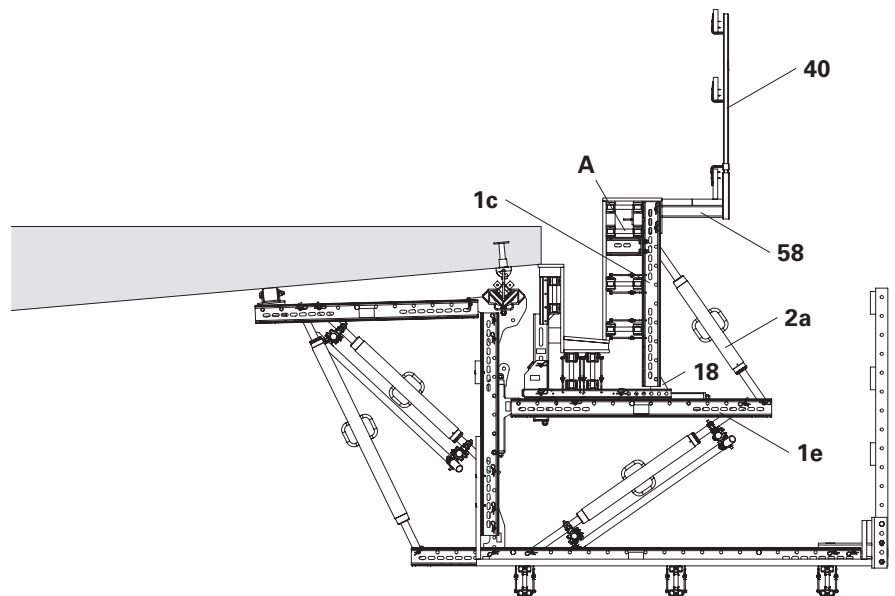

Fig. B8.02

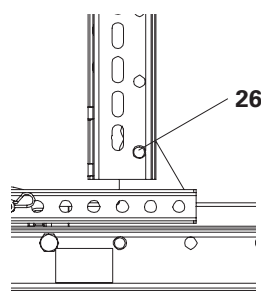

Fig. B8.02a

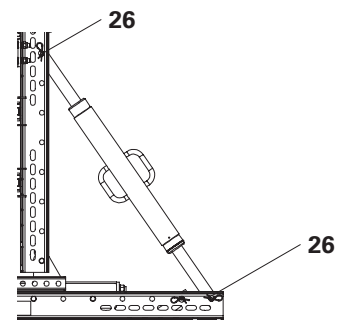

Fig. B8.02b

## Internal formwork

### Assembly

1. Insert pre-assembled slab formwork B into the Steel Waler SRU U120 (1e).
2. Bolt slab formwork B onto the Adjusting Unit VARIOKIT (18) using 1x fitting pin Ø 21 mm (26).
3. Bolt Lift Protector SRU (5) onto the Steel Waler SRU U120 (1e) using 2x fitting pins Ø 21 mm (26).

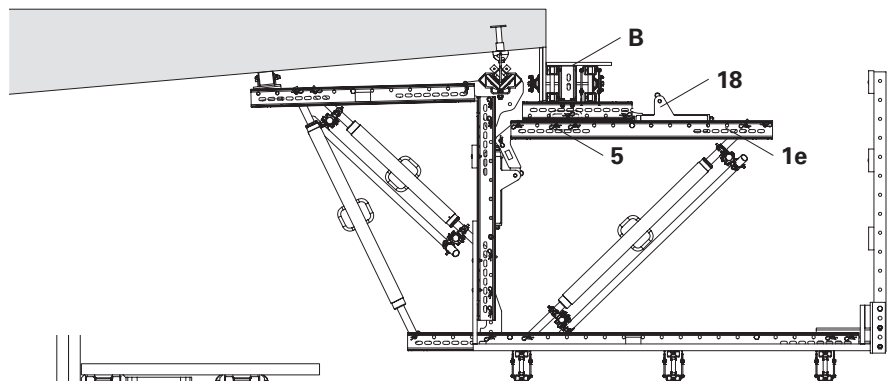

Fig. B9.01

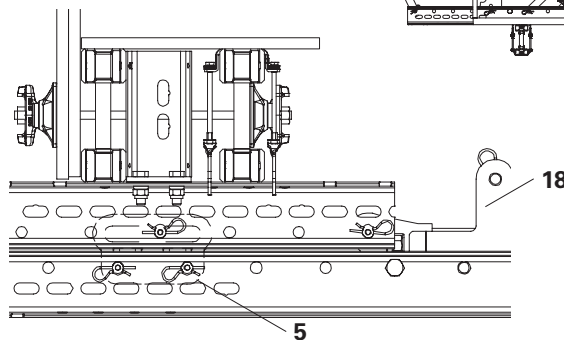

Fig. B9.01a

## External formwork



Ensure there is sufficient overlap length on the decking and handrail boards to prevent any tipping.

### Assembly

1. Bolt Platform Beam SRU (58) onto the Steel Waler SRU U120 (1c) of the pre-assembled external formwork element A using 2x fitting pins Ø 21 mm (26).
2. Insert Guardrail Post HSGP-2 (40) into the Platform Beam SRU (58).
3. Attach handrail boards and platform decking, and fix using screws.
4. Bolt the external formwork element Steel Waler SRU U120 (1c) with platform beam onto the Adjusting Unit VARIOKIT (18) using 1x fitting pin Ø 21 mm (26).
5. Bolt the Heavy-Duty Spindle SLS (2a) between the Steel Waler SRU U120 (1c) and Steel Waler SRU U120 (1e) using 2x fitting pins Ø 21 mm (26).

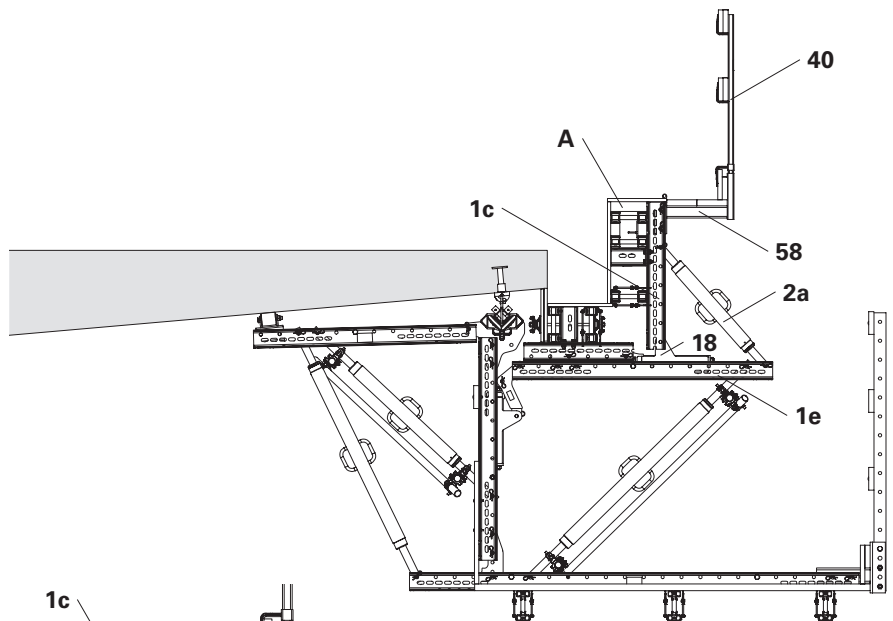

Fig. B9.02

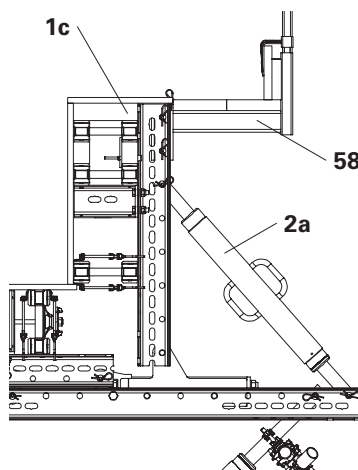

Fig. B9.02a

# C1 Basic settings before initial concreting work – Formwork type 1

## Tools

<b>072180</b>	Ratchet wrench 1/2"
<b>104823</b>	Socket AF 30-1/2"

### Vertical adjustment

1. Carry out vertical fine adjustment with the Adjusting Unit VARIOKIT (18a) and Heavy-Duty Spindle SLS (2b) or (2c). (Fig. C1.01a + C1.01b)
2. Slightly loosen the Swivel Coupling AF 48/48 (36) on the diagonal steel scaffolding tube (34b).
3. Height adjustment is carried out by turning the Adjusting Unit VARIOKIT (18a) using a ratchet wrench and socket AF 30. (Fig. C1.01a)
4. Horizontally align the Steel Waler SRU U120 (1e) using the Heavy-Duty Spindle SLS (2b) or (2c).
5. Tighten the Swivel Coupling AF 48/48 (36) on the diagonal steel scaffolding tube (34b).
6. By turning the nut on the Standard VGB (3.1) using a ratchet wrench and socket AF 30, superstructure inaccuracies can be compensated.

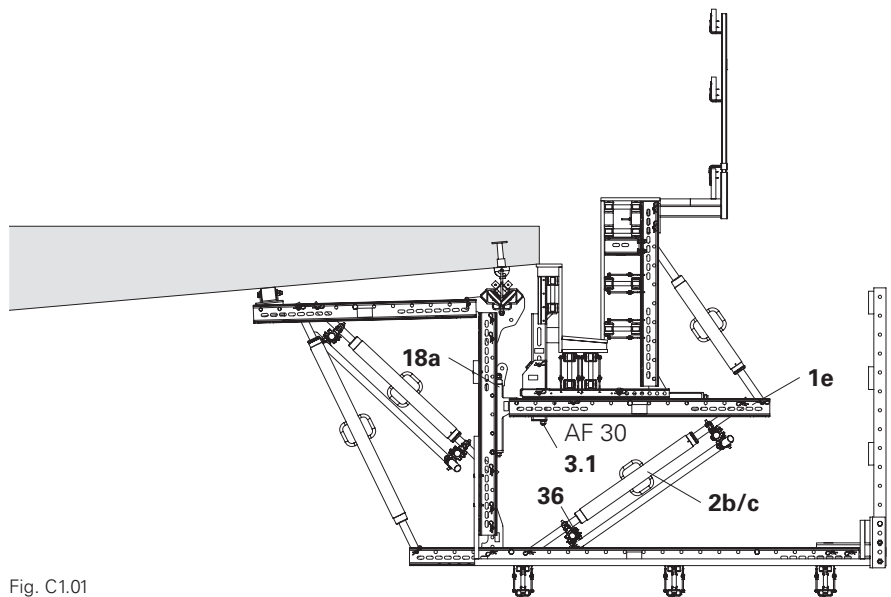

Fig. C1.01

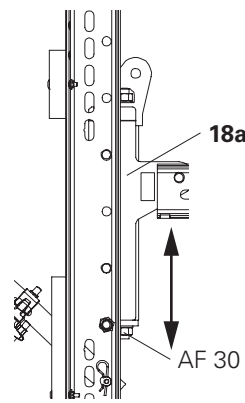

Fig. C1.01a

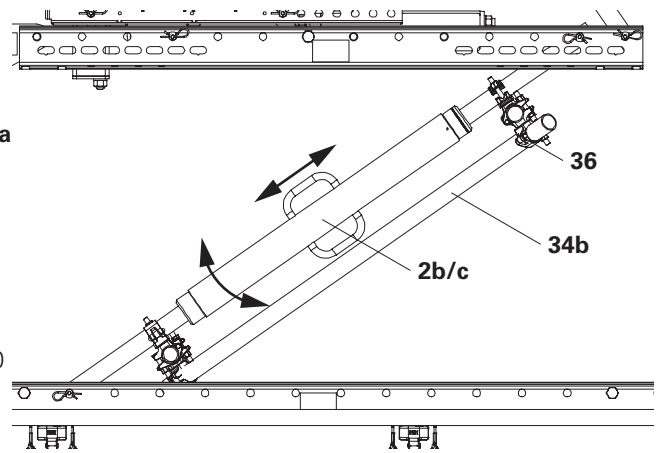

Fig. C1.01b

### Horizontal adjustment

1. Bring internal formwork into position by turning the Adjusting Unit VARIOKIT (18b) using a ratchet wrench and socket AF 30.
2. Align the external formwork using the Heavy-Duty Spindle SLS (2a).

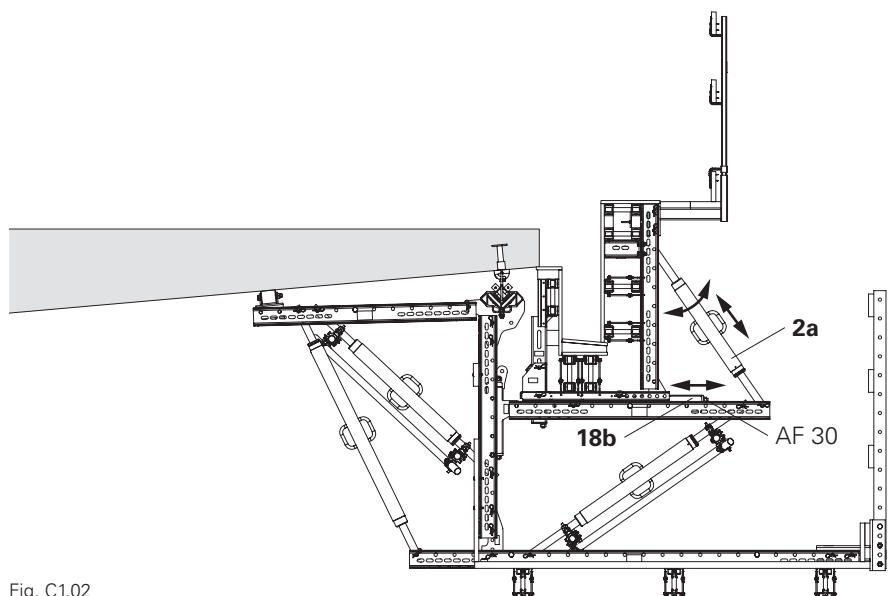

Fig. C1.02



# C2 Basic settings before initial concreting work – Formwork type 2

### Tools

<b>072180</b>	Ratchet wrench 1/2"
<b>104823</b>	Socket AF 30-1/2"

### Vertical adjustment

1. Carry out vertical fine adjustment with the Adjusting Unit VARIOKIT (18a) and Heavy-Duty Spindle SLS (2b) or (2c). (Fig. C2.01a + C2.01b)
2. Slightly loosen the Swivel Coupling AF 48/48 (36) on the diagonal steel scaffolding tube (34b).
3. Height adjustment is carried out by turning the Adjusting Unit VARIOKIT (18a) using a ratchet wrench and socket AF 30. (Fig. C2.01a)
4. Horizontally align the Steel Waler SRU U120 (1e) using the Heavy-Duty Spindle SLS (2b) or (2c).
5. Tighten the Swivel Coupling AF 48/48 (36) on the diagonal steel scaffolding tube (34b).
6. Superstructure inaccuracies can be compensated by placing wooden wedges under the internal formwork.

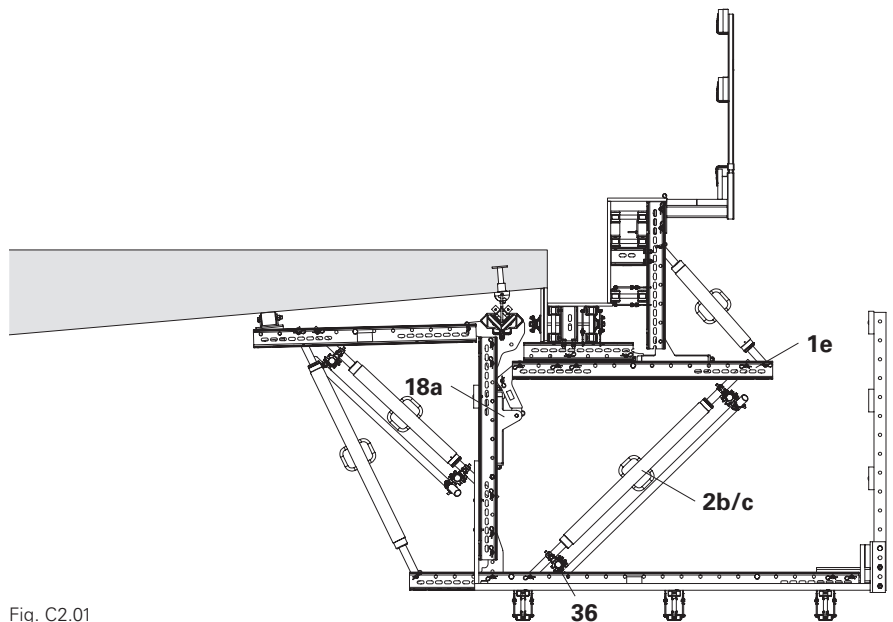

Fig. C2.01

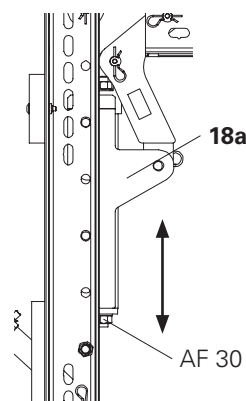

Fig. C2.01a

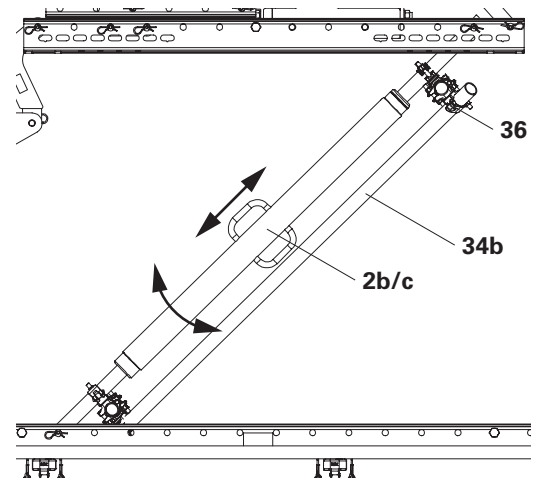

Fig. C2.01b

### Horizontal adjustment

1. Bring internal formwork into position by turning the Adjusting Unit VARIOKIT (18b) using a ratchet wrench and socket AF 30.
2. Align the external formwork using the Heavy-Duty Spindle SLS (2a).

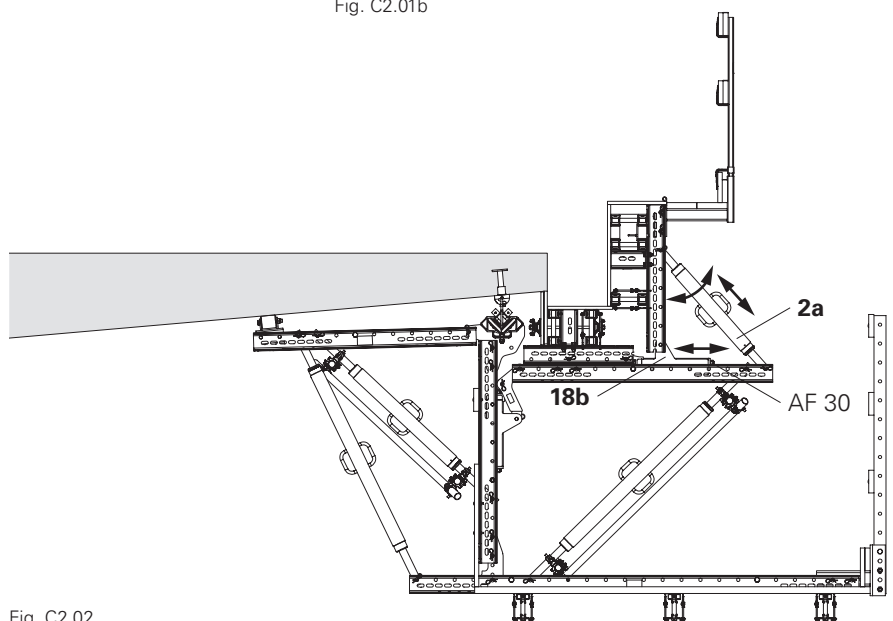

Fig. C2.02

## Tools

<b>072180</b>	Ratchet wrench 1/2"
<b>104823</b>	Socket AF 30-1/2"

### Slab and internal formwork

1. The position of the slab formwork is aligned by means of the Adjusting Unit VARIOKIT (18).
2. Internal formwork can be adjusted by turning the nut on the Standard VGB (3) and pressing firmly against the lower edge of the superstructure with the ratchet wrench and socket AF 30.

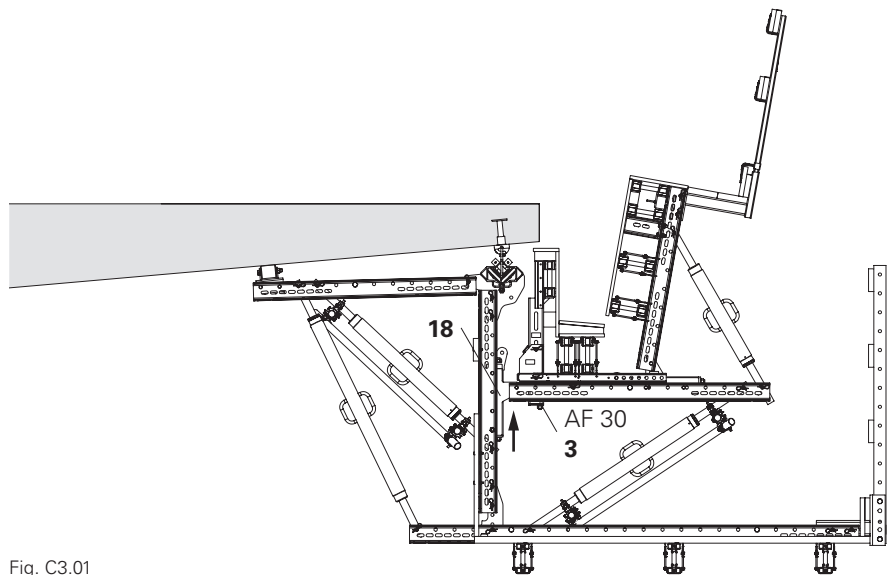

Fig. C3.01

### External formwork

1. Bring the external formwork into position by turning on the Heavy-Duty Spindle SLS (2a).

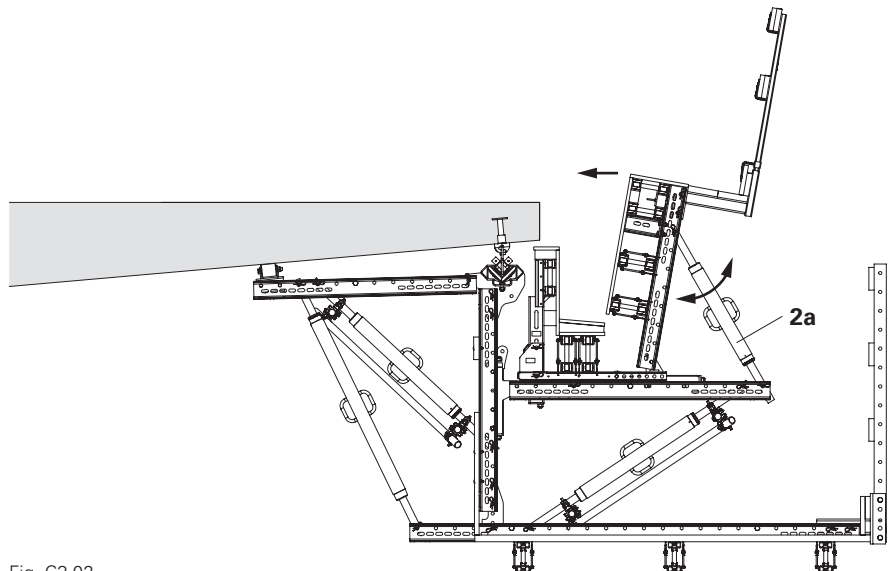

Fig. C3.02

### Concreting position

1. Install reinforcement.
2. Concrete cantilevered parapet. (see Section C5)

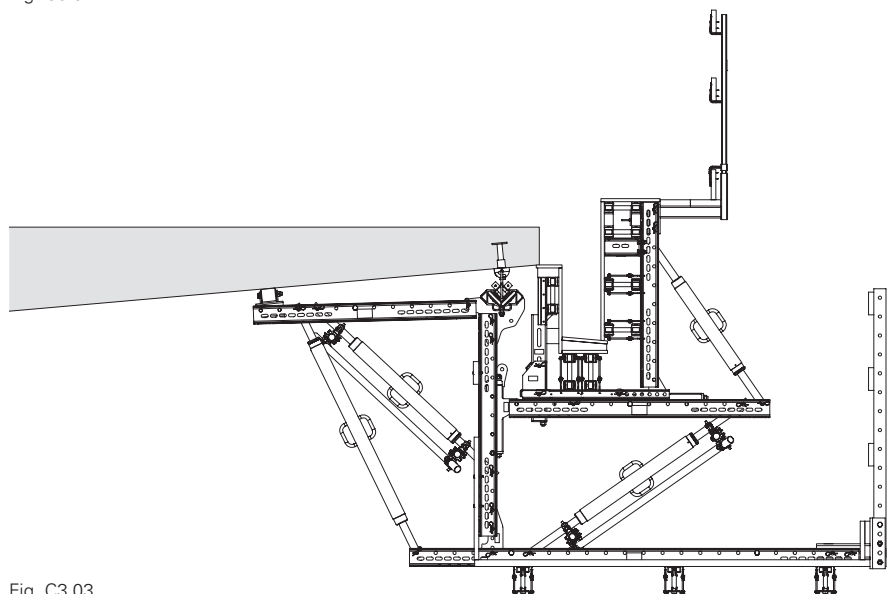

Fig. C3.03

### Slab and internal formwork

1. The position of the slab formwork is aligned by means of the Adjusting Unit VARIOKIT (18).
2. Press internal formwork with wooden wedges against the superstructure.

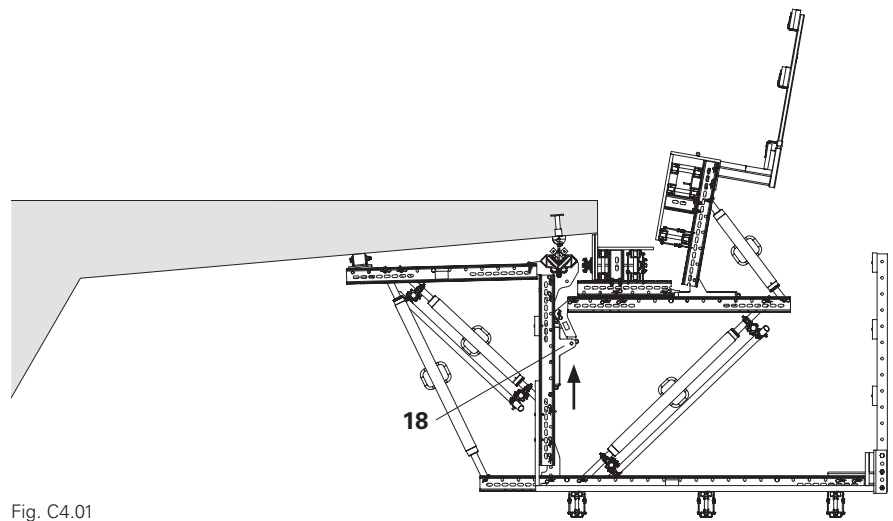

Fig. C4.01

### External formwork

1. Bring the external formwork into position by turning on the Heavy-Duty Spindle SLS (2a).

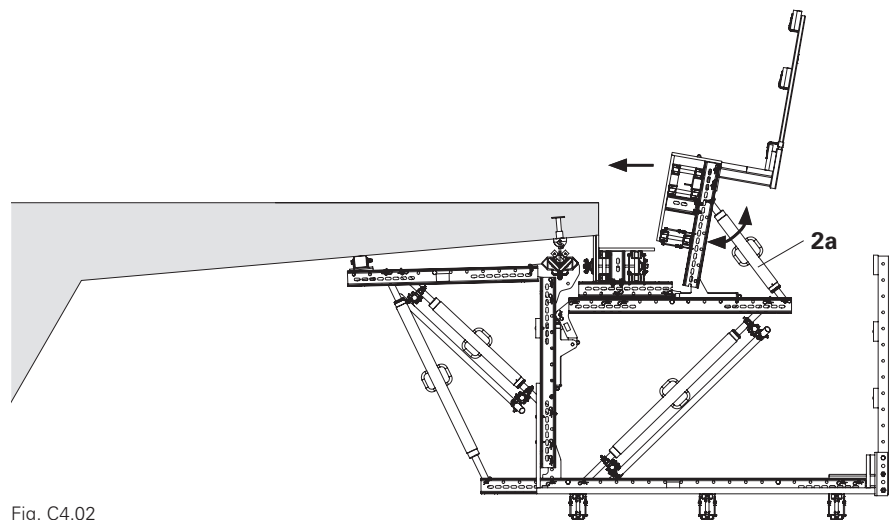

Fig. C4.02

### Concreting position

1. Install reinforcement.
2. Concrete cantilevered parapet. (see Section C5)

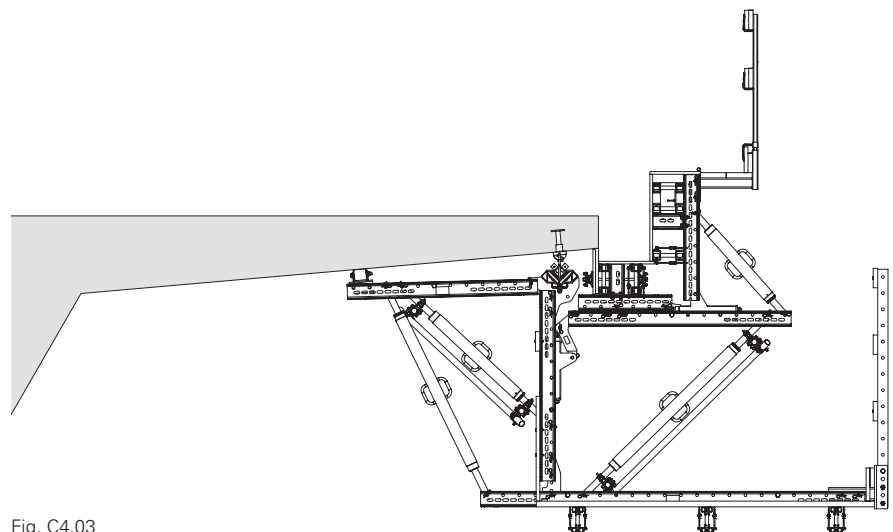

Fig. C4.03

## Concreting position



### Danger

Danger associated with overloading! VGB Parapet Track or platforms could fall to the ground.

- ⇒ During concreting, all vertical Steel Walers SRU U120 (**1d**) of the track must be positioned centrally under the suspension points (**1**). Acceptable is +/- 10 cm within the reinforcement of the Rails 100 VARIOKIT (**32a**) or 150 VARIOKIT (**32b**).
- ⇒ Do not pour concrete directly from the mixer truck or concrete bucket into the formwork construction.
- ⇒ Avoid any accumulation of concrete in the area of the VGB Parapet Track.

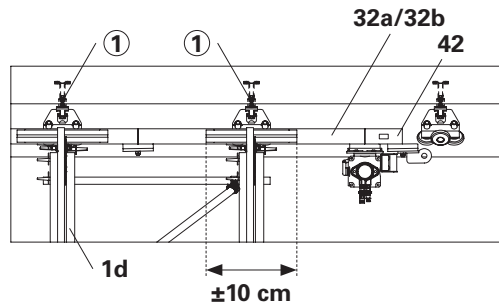

Fig. C5.01

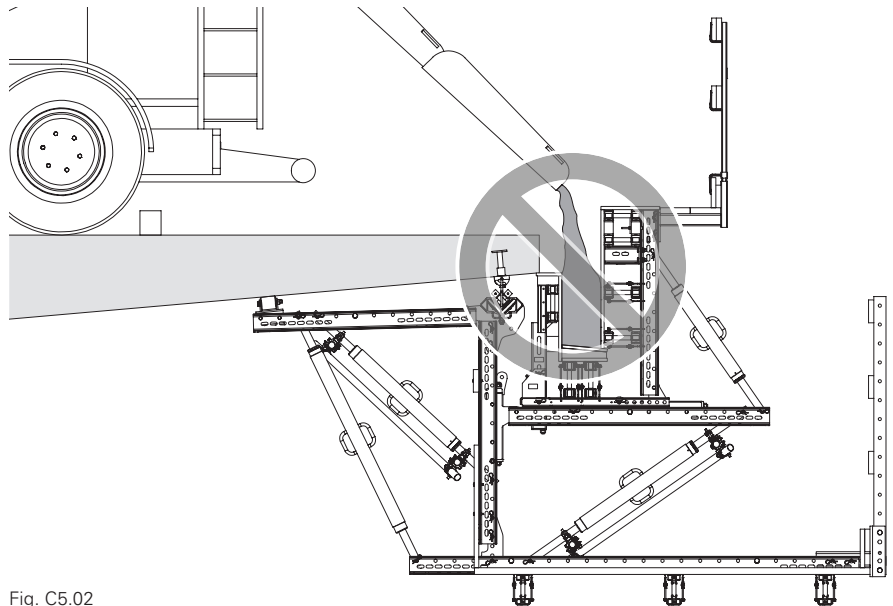

Fig. C5.02

### Concreting

1. Pour concrete on the bridge cantilever.
2. Bring concrete into the formwork construction using a rake or something similar.
3. Compact the concrete.

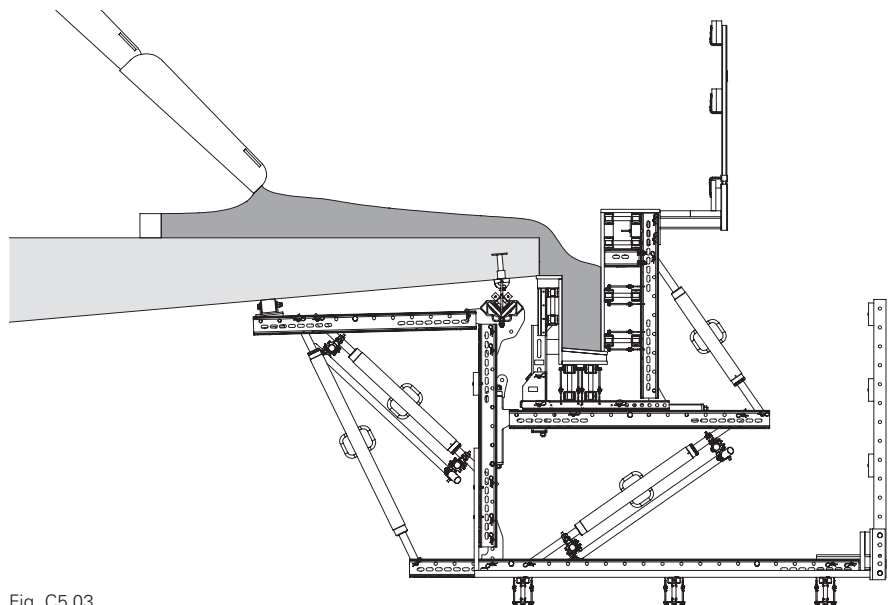

Fig. C5.03

## External formwork

1. Release the external formwork by turning on the Heavy-Duty Spindle SLS (**2a**).

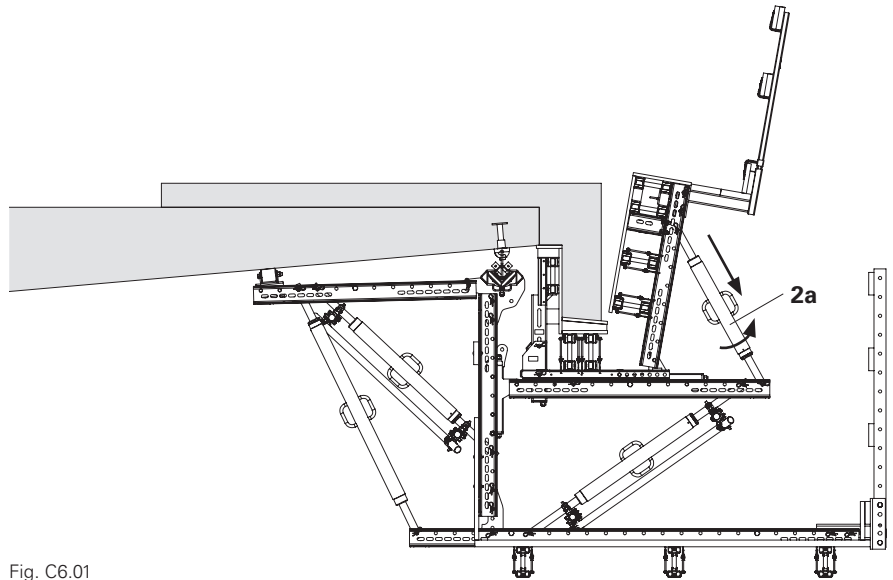

Fig. C6.01

## Tools

<b>072180</b>	Ratchet wrench 1/2"
<b>104823</b>	Socket AF 30-1/2"

## Slab and internal formwork

1. Release the slab and internal formwork by lowering the Adjusting Unit VARIOKIT (**18**) using a ratchet wrench and socket AF 30.
2. After striking the formwork, the VGB Parapet Track can be moved to the next concreting section.

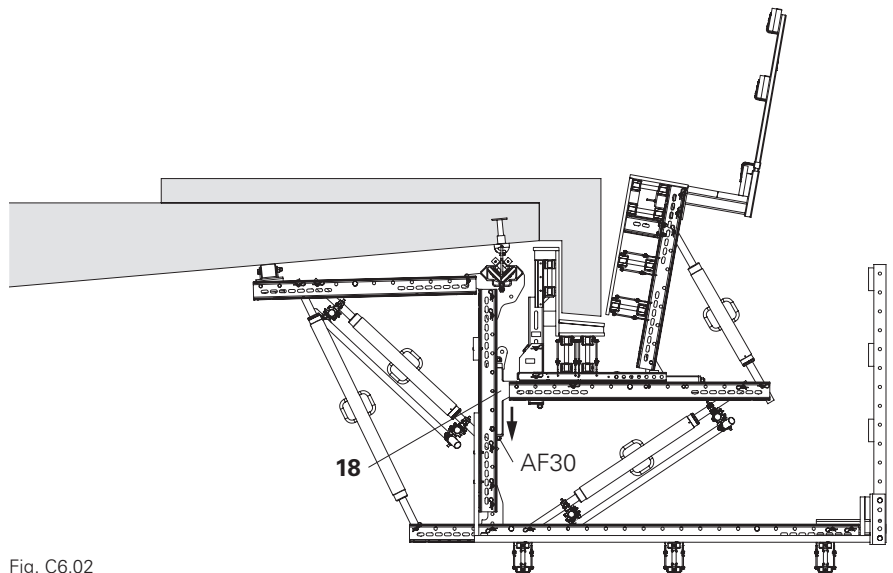

Fig. C6.02

## External formwork

1. Release the external formwork by turning on the Heavy-Duty Spindle SLS (**2a**).

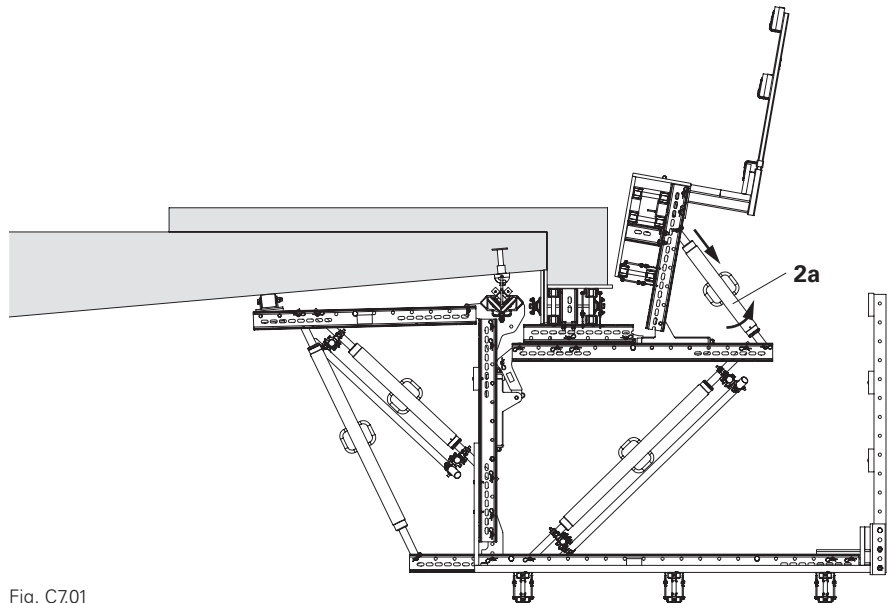

Fig. C7.01

## Tools

<b>072180</b>	Ratchet wrench 1/2"
<b>104823</b>	Socket AF 30-1/2"

## Slab formwork

1. Release the slab formwork by lowering the Adjusting Unit VARIOKIT (**18**) using a ratchet wrench and socket AF 30.
2. After striking the formwork, the VGB Parapet Track can be moved to the next concreting section.

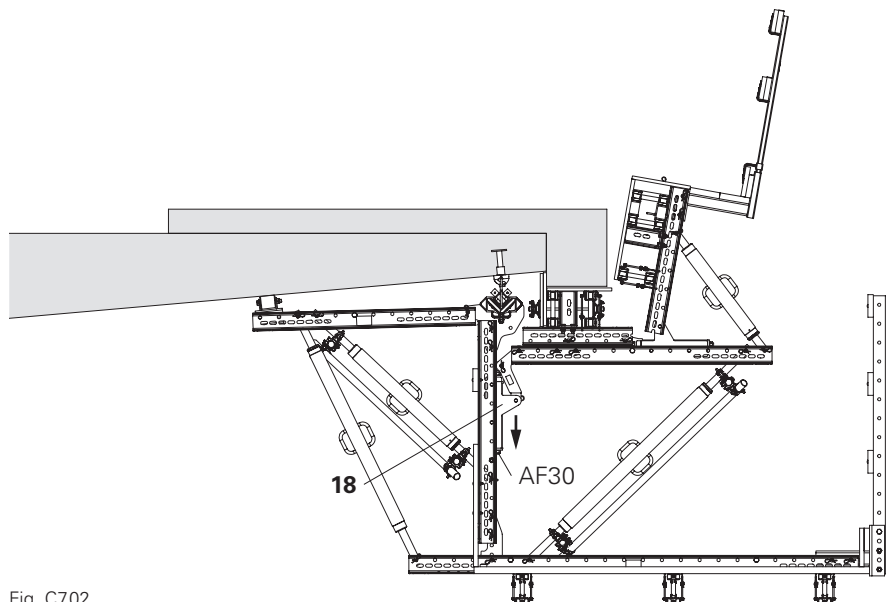

Fig. C7.02



- The recommended moving and concreting length of the VGB Parapet Track is 25 m.
- Always pull in the axis direction of the rails.
- After dismantling the Roller Units VARIOKIT (7) and Suspension Heads M24 VARIOKIT (14), the tie holes must be closed. (see Section A5)
- When using the Hydr. Traction Cable Winch H60, observe the assembly instructions for the VGB Pulling Unit.

Depending on the radius of the curve and the geometry of the superstructure, the optimum length for the relocation procedure could be < 25 m, depending on the project.

Relocation can be carried out either with the PERI H60 Hydr. Traction Cable Winch, which is attached directly to the leading platform, or with a relocation device provided by the contractor, which is attached to the lug of the Travelling Nose 25-2 VARIOKIT. (Fig. B8.02)

### Assembling the tension shoe

1. Attach the Tension Shoe VGB-2 (59) to the Anchor Sleeve M24 (9) using bolts M24 x 150 (15).

During the relocation operation, the Roller Units VARIOKIT (7) and Suspension Heads M24 VARIOKIT (14) are removed from the finishing platform, brought to the leading platform and mounted at the front.



The GKB Work Cage can be used for assembling the tension shoe.

### Version 1: site-specific relocation procedure

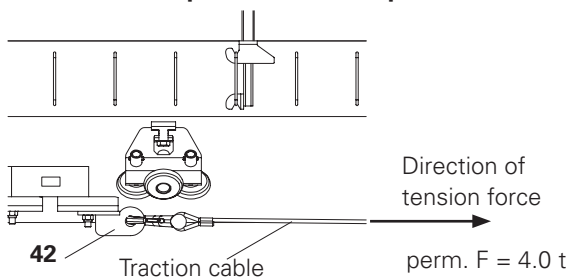

Fig. C8.02

### Variant 2: Relocation with the Hydr. Traction Cable Winch H60

Follow the Assembly Instructions for the VGB Pulling Unit.

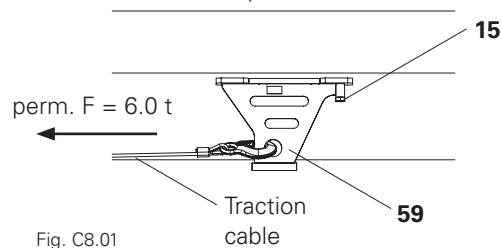

Fig. C8.01

## Moving procedure

### Step 1

1. Remove the Roller Unit VARIOKIT (7).
2. Unscrew the Suspension Anchor M24 VARIOKIT (14).
3. Close the tie hole. (see Section A5)
4. Transport the Suspension Anchor M24 VARIOKIT (14) and Roller Unit VARIOKIT (7) to the leading platform.

### View of the finishing platform

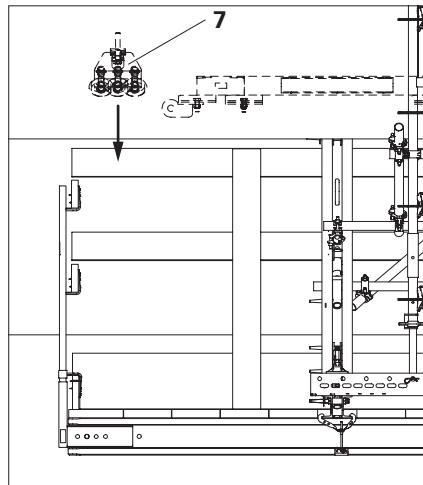

Fig. C8.03

### Step 2

1. Screw Suspension Anchor M24 VARIOKIT (14) into Anchor Sleeve M24 (9).
2. Attach the Roller Unit VARIOKIT (7).
3. Move the VGB Parapet Track to the next anchor sleeve.

Repeat operational steps 1 and 2 until the next concreting section has been reached.



We recommend fitting the Roller Units VARIOKIT (7) with the double roller side alternating outward and inward. (see Section B7)

### View of the leading platform

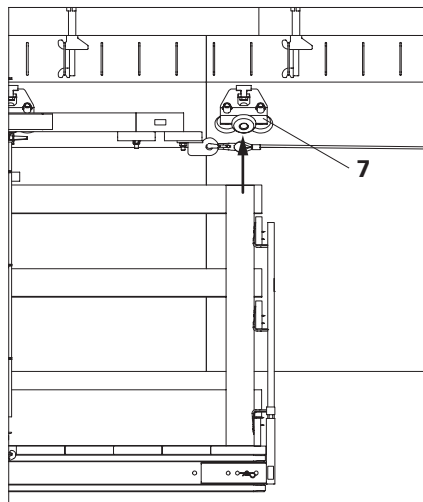

Fig. C8.04



## Horizontal holder with the Tension Shoe VGB

1. Ensure that the connection between the Tension Shoe-2 VGB (**59**) and Rail Slide 25-2 VARIOKIT (**42**) is very tight.

The leading and finishing platforms should be mounted horizontally if the bridge has a longitudinal inclination or for storm protection.

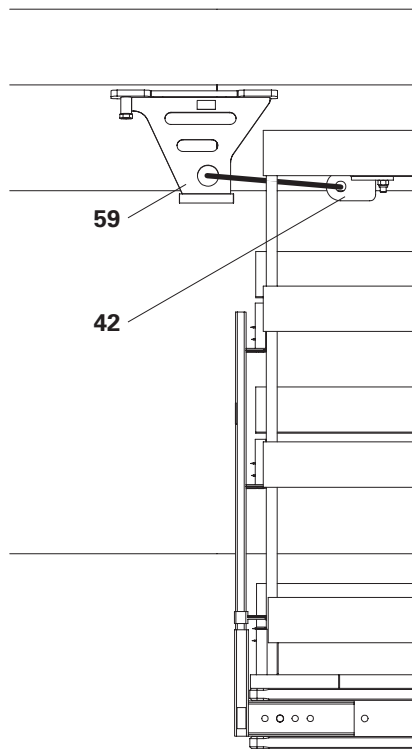

Fig. C9.01



Disassembly is carried out in the reverse order to the assembly procedure (see Section B7).

## Disassembly procedure

1. Remove the finishing platform.
2. Remove the leading platform.



The leading platform is normally lifted out shortly before reaching the final position in the last concreting section in order to concrete the cantilevered parapet at the transition area to the abutment. (see Section B7)

3. Remove the standard concreting units.



All valid safety regulations are to be observed during all dismantling and construction stages. In particular, anti-fall prevention measures are to be used at all times so that the working area is safe and can be safely used for work operations.



If required, secure the platform units in the various detachment states to prevent any horizontal movement.

## Working procedure during lifting

1. Project-specific disassembly of the formwork units.
2. Release the Connecting Bolt M20 on the rail to the next platform unit.

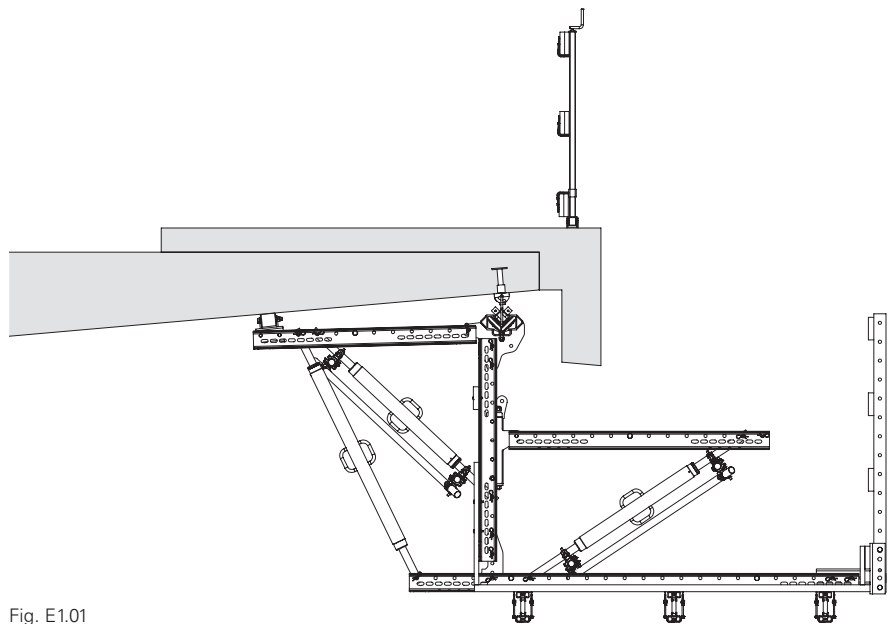

Fig. E1.01

1. Attach the crane lifting gear to the auxiliary construction and Lifting Eye BR-2 2.5 t (**57**). (see Section B5)
2. Pull out platform unit laterally.
3. Set platform unit down on the assembly area, safely dismantle and store.

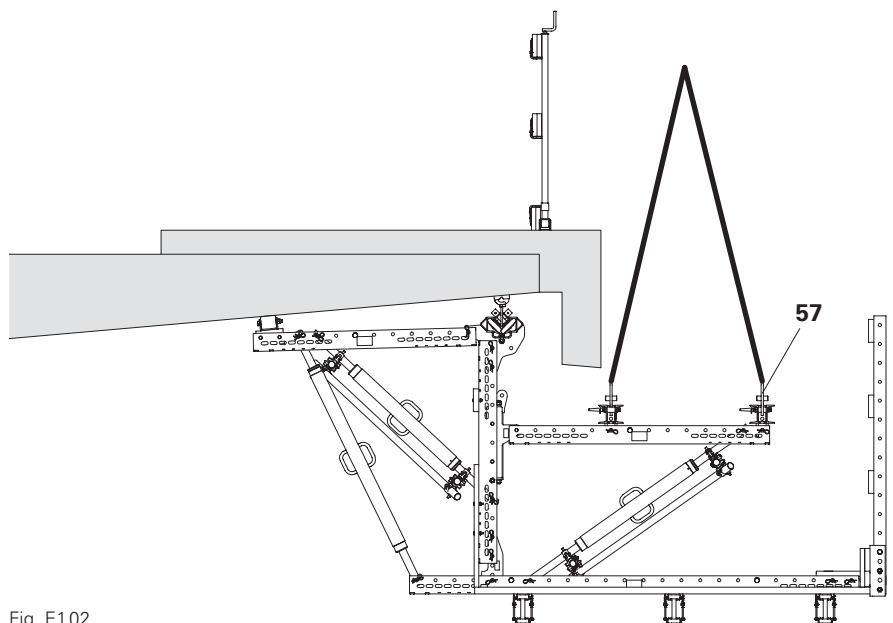

Fig. E1.02

Article no. Weight kg

116291	41.300
116297	52.100

**Guide Rails VARIOKIT**  
**Guide Rail 100 VARIOKIT**  
**Guide Rail 150 VARIOKIT**

Rails can be coupled with M20 screw.  
 Guided by the Roller Unit VARIOKIT.  
 Connection option to SRU Ledger.

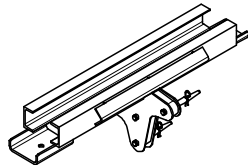

**Complete with**

- 3 pcs. 104031 fitting pin  $\varnothing$  21 x 120
- 3 pcs. 018060 Cotter Pin 4/1, galv.
- 1 pc. 113546 bolt ISO 4017 M20 x 45-8.8, galv.
- 1 pc. 781056 Top Duo Tread Plate 712 x 835

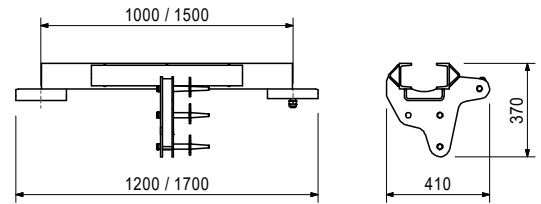

131430	12.300
--------	--------

**Rail Slide 25-2 VARIOKIT**

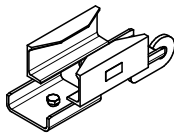

**Complete with**

- 1 pc. 057139 bolt ISO 4017 M20 x 60-8.8, galv.
- 1 pc. 781053 nut ISO 7040 M20-8, galv.

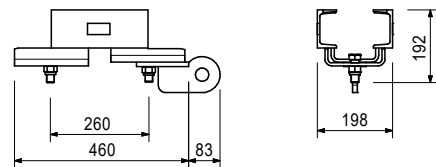

131420	2.720
--------	-------

**Spindle Cross-Connector SRU**

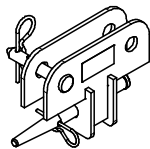

**Complete with**

- 1 pcs. 104031 fitting pin  $\varnothing$  21 x 120
- 1 pcs. 018060 Cotter Pin 4/1, galv.
- 1 pc. 018050 bolt  $\varnothing$  16 x 65/86, galv.
- 1 pcs. 022230 cotter pin 5/1, galv.

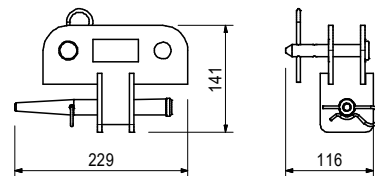

114599	4.980
--------	-------

**Pressure Roller VARIOKIT**

For installation in SRU Ledgers. Serves as a movable pressure point.

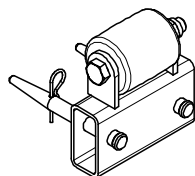

**Complete with**

- 2 pcs. 104031 fitting pin  $\varnothing$  21 x 120
- 2 pcs. 018060 Cotter Pin 4/1, galv.

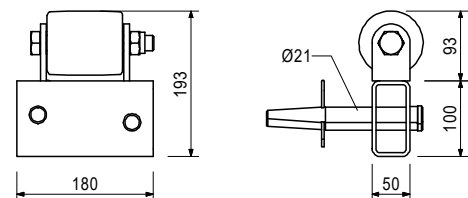

Article no. Weight kg

123727 6.780

### Adapter VGB

For vertical adjustment of the formwork with small caps.

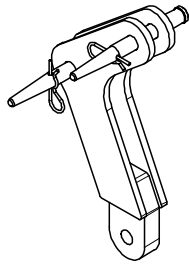

### Complete with

2 pcs. 104031 fitting pin Ø 21 x 120  
2 pcs. 018060 Cotter Pin 4/1, galv.

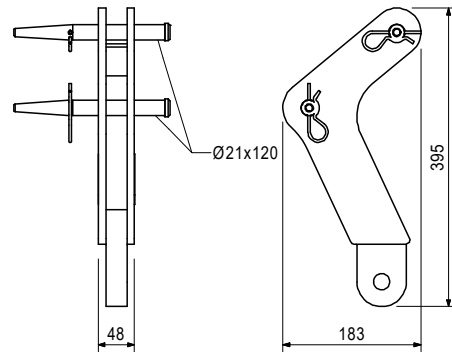

123732 3.130

### Lift Protector SRU

For assembling the slab formwork on the Steel Walers SRU in the case of small caps.

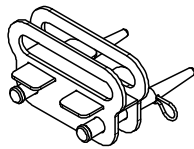

### Complete with

2 pcs. 104031 fitting pin Ø 21 x 120  
2 pcs. 018060 Cotter Pin 4/1, galv.

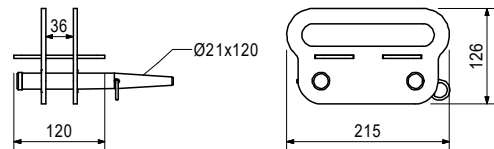

116446 16.100

### Formwork Girder VGB 90

For horizontal adjustment of the formwork and supporting the internal formwork in the case of large caps.

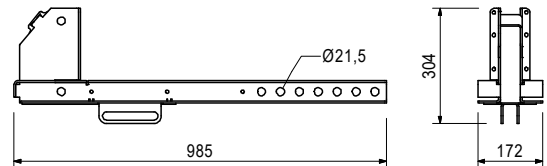
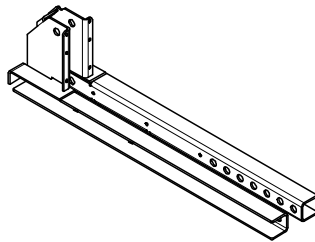

Accessories

104031 0.462  
018060 0.014

**Fitting pin Ø 21 x 120**  
**Cotter Pin 4/1, galv.**

Article no. Weight kg

118258 8.400

### Vertical Post VGB 100

For adjusting to the internal height of the cantilevered parapets in the case of large caps.

### Complete with

2 pcs. 104031 fitting pin  $\varnothing$  21 x 120  
2 pcs. 018060 Cotter Pin 4/1, galv.

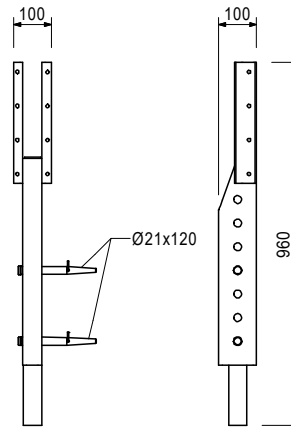
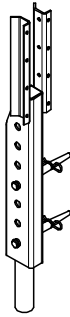

124905 14.300

### Vertical Post VGB 100, adjustable

For continuous adjusting to the internal height of the cantilevered parapets in the case of large caps.

### Complete with

2 pcs. 104031 fitting pin  $\varnothing$  21 x 120  
2 pcs. 018060 Cotter Pin 4/1, galv.

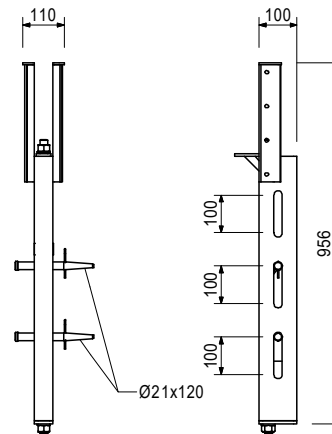
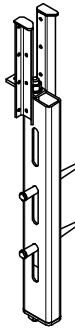

115623 5.040

### Connector SRU VARIOKIT

For rigid connection of Steel Walers SRU.

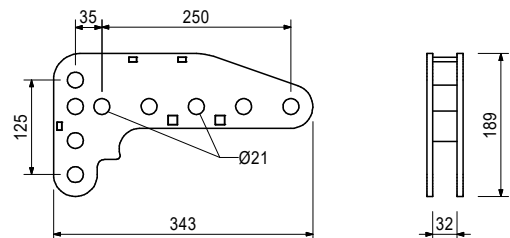
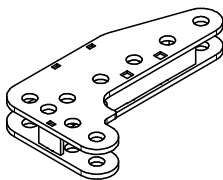

104031 0.462  
018060 0.014

Accessories

**Fitting pin  $\varnothing$  21 x 120**  
**Cotter Pin 4/1, galv.**

Article no. Weight kg

111283 9.950

## Angle Connector RCS/SRU

For right-angled connection of Steel Walers SRU to Climbing Rails RCS and assembling guardrail posts to Steel Walers SRU.

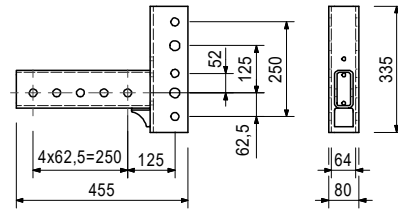
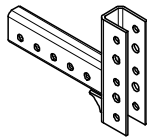

### Accessories

104031 0.462

**Fitting pin Ø 21 x 120**

018060 0.014

**Cotter Pin 4/1, galv.**

111567 0.729

**Fitting pin Ø 26 x 120**

022230 0.033

**Cotter pin 5/1, galv.**

113933 17.400

## Adjusting Unit VARIOKIT

As an articulated joint for SRZ and SRU Steel Walers. With integrated adjustment.

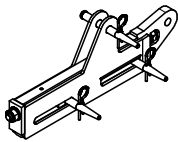

### Complete with

3 pcs. 104031 fitting pin Ø 21 x 120

3 pcs. 018060 Cotter Pin 4/1, galv.

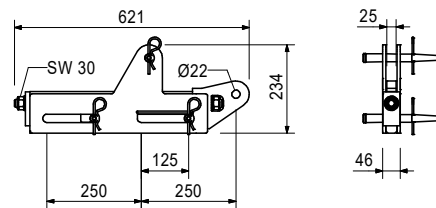

### Accessories

104031 0.462

**Fitting pin Ø 21 x 120**

018060 0.014

**Cotter Pin 4/1, galv.**

037150 0.641

## Tie Yoke DW 15

For fixing Steel Waler SRZ to the strongback.

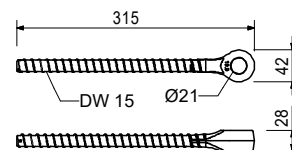
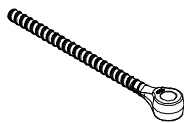

### Accessories

037160 0.736

**Locking pin Ø 20 x 205, galv.**

781053 0.065

**Nut ISO 7040 M20-8, galv.**

710226 0.340

**Bolt ISO 4014 M20 x 90-8.8, galv.**

Article no. Weight kg

030370 1.660

### Wingnut Pivot Plate DW 15, galv.

For anchoring with Tie Rod DW 15 and B 15.  
With articulated, captive nut. Maximum inclination of anchor: 8°.

### Note

Width across flats AF 27.

### Technical data

Permissible load 90 kN.

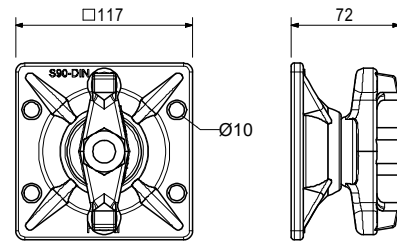
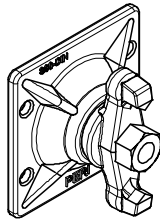

100093 5.870

### Wall Tie UWT 140

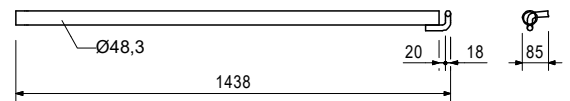
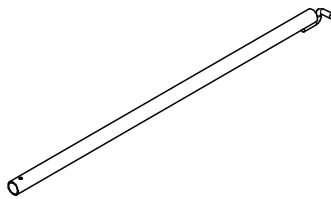

104031 0.462

### Fitting pin Ø 21 x 120

For various connections.

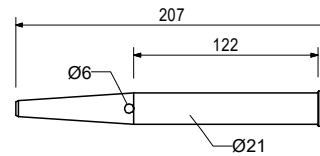
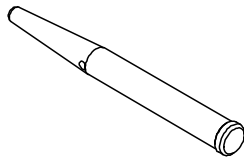

Accessories

018060 0.014

### Cotter Pin 4/1, galv.

018060 0.014

### Cotter Pin 4/1, galv.





Article no. Weight kg

111279 2.450

### Cross Connector VARIOKIT

For right-angled connection of Steel Walers SRU to SRU or of Steel Walers SRU to RCS.

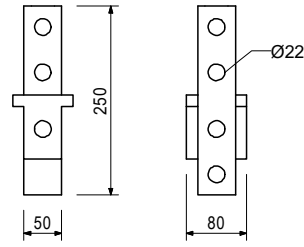
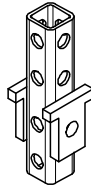

Accessories

104031 0.462  
018060 0.014

**Fitting pin Ø 21 x 120**  
**Cotter Pin 4/1, galv.**

127834 2.210

### Lifting Eye BR-2 2.5 t, galv.

Attachment point for moving climbing systems or Platform Beams BR.

#### Note

Follow the instructions for use!

#### Technical data

Permissible load-bearing capacity 2.5 t.

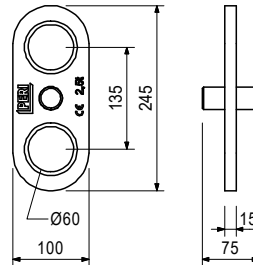

Accessories

020620 0.561

### Spacer for Platform Beam BR

026230 1.010

### Anchor Sleeve M24

For anchoring of platform systems.

#### Note

Separate structural design information on request.

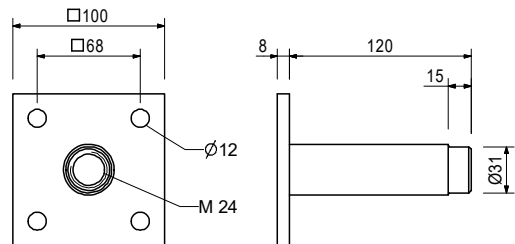
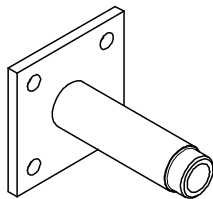

Accessories

026240 0.026  
026250 0.005  
116233 0.116  
026420 0.123  
116234 0.033  
115150 0.200  
123800 0.045

**Spacer PP Ø 31/26, c = 25**  
**Plug PP Ø 26 mm**  
**Cone FRC Ø 32/52, c = 40**  
**Anchor Positioning Stud M24, galv.**  
**Plug FRC Ø 32**  
**Anchor Positioning Stud M24 x 65, galv.**  
**Metric Threaded Cone M24**

Article no. Weight kg

123800 0.045

### Metric Threaded Cone M24

For advanced mounting of the Anchor Sleeve M24 with 40 mm concrete cover in bridge cantilevers.

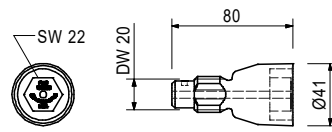
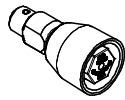

Accessories

026230 1.010

### Anchor Sleeve M24

123820 0.063

### Plug FRC Ø 40

129157 0.017

### Nail 4.6 x 130

129157 0.017

### Nail 4.6 x 130

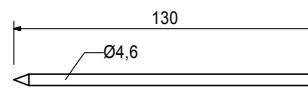
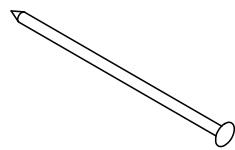

116233 0.116

### Cone FRC Ø 32/52, c = 40

Results in concrete cover of 40 mm in combination with Anchor Sleeve M24. Made of fibre-reinforced concrete.

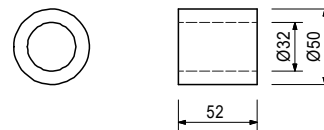
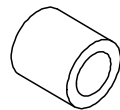

115150 0.200

### Anchor Positioning Stud M24 x 65, galv.

For fixing Anchor Sleeve M24 if the formlining cannot be drilled.

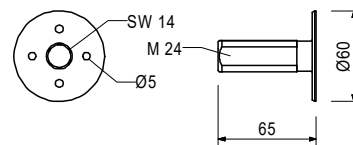
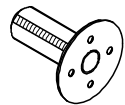

114534 2.220

### Suspension Anchor M24 VARIOKIT

Fixing material for suspending the Roller Unit VARIOKIT under the bridge cantilever slab.

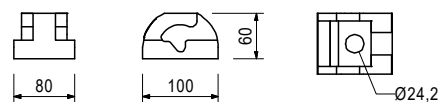
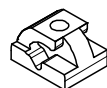

Article no. Weight kg

104540 0.654 **Bolt ISO 4014 M24 x 150-8.8, galv.**

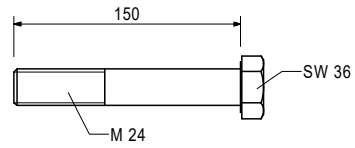
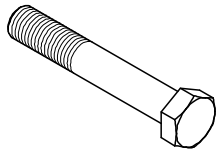

114535 18.000 **Roller Unit VARIOKIT**  
Rolling link and suspension for  
Guide Rail VARIOKIT.

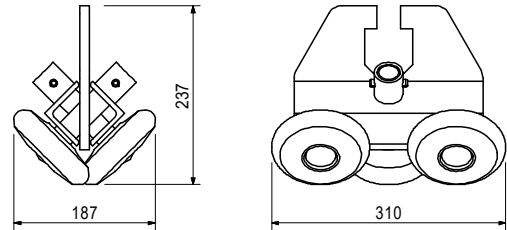
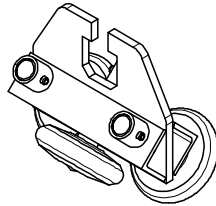

123820 0.063 **Plug FRC Ø 40**  
For closing the tie hole when using the Metric  
Threaded Cone M24.

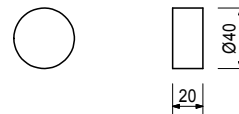

116234 0.033 **Plug FRC Ø 32 mm**  
For closing the FRC Tube Ø 32 mm. Made of  
fibre-reinforced concrete.

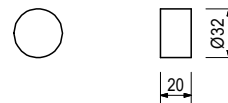

031550 1.000 **Repoal Glue**  
2-component adhesive for bonding fibre cement  
plugs. Consumption: 1 kg adhesive for approx.  
200 Plugs FCP 32 or 330 Plugs FCP 22.

**Note**  
Observe safety data sheet!  
Delivery unit: 1.0 kg

# VGB Parapet Track



Article no. Weight kg

131707 12.800

## Tension Shoe-2 VGB

Tension Shoe-2 VGB for relocating the VGB Parapet Track.

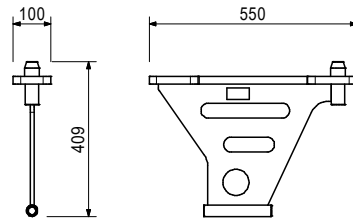
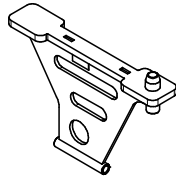

Accessories

104540 0.654

## Bolt ISO 4014 M24 x 150-8.8, galv.

051410 11.700

## Ladder 180/6, galv.

For accessing PERI formwork systems.

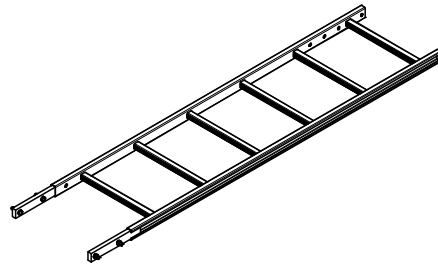

## Complete with

4 pc. 710224 bolt ISO 4017 M12 x 40-8.8, galv.  
4 pc. 710381 nut ISO 7040 M12-8, galv.

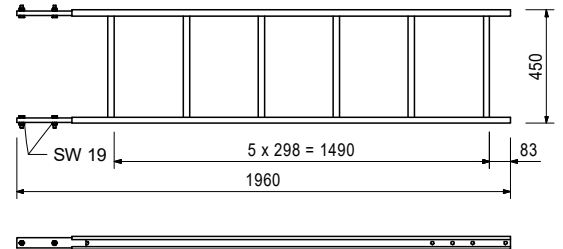

103724 10.400

## Access ladder 180/2, galv.

For accessing PERI formwork systems.

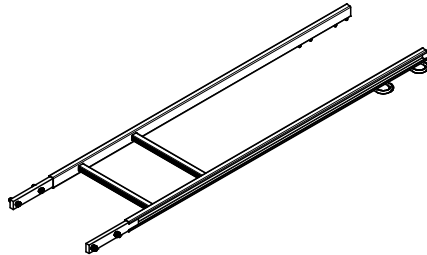

## Complete with

4 pc. 710224 bolt ISO 4017 M12 x 40-8.8, galv.  
4 pc. 710381 nut ISO 7040 M12-8, galv.

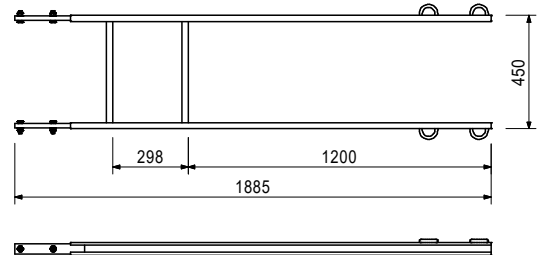

051460 2.180

## Ladder base, galv.

As bottom ladder connection and for securing ladders against sliding on the scaffold decks.

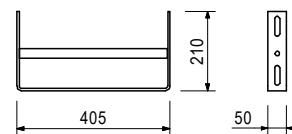
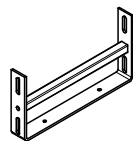

Article no. Weight kg

104132	15.600
051450	25.200

**Ladder cage**

**Ladder Safety Cage 75, galv.**

**Ladder Safety Cage 150, galv.**

Ladder cage for PERI ladder access.

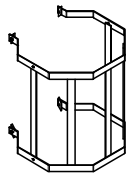

**Complete with**

4 pc. 710266 bolt ISO 4017 M12 x 25-8.8, galv.

4 pc. 701763 Clamping Plate FI 25 x 10 x 90

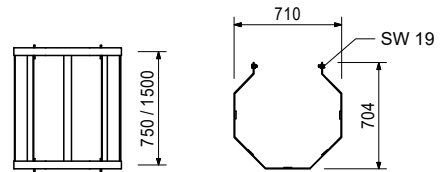

124813	4.000
--------	-------

**Ladder Connector UAC-2**

**Complete with**

1 pc 051410 Ladder 180/6, galv.

**Note**

Connects Ladder 180/6 (Article No. 051410) with PERI UP Standards.

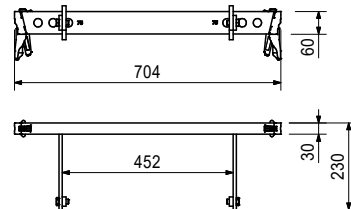
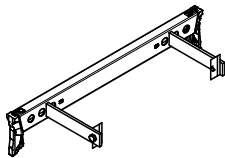

Accessories

051410	11.700
051460	2.180
103724	10.400
104132	15.600
051450	25.200

**Ladder 180/6, galv.**

**Ladder base, galv.**

**Access ladder 180/2, galv.**

**Ladder Safety Cage 75, galv.**

**Ladder Safety Cage 150, galv.**

100005	9.240
--------	-------

**Top Standard UVH 200**

Without pin for mounting head spindles.

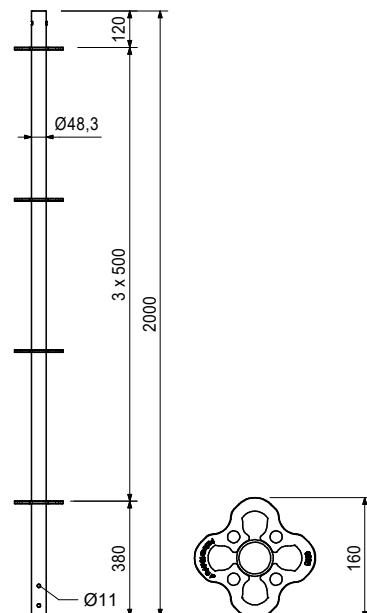

Article no. Weight kg

114632	4.390	<b>Ledger UH Plus</b>
114638	5.340	<b>Ledger UH 100 Plus</b>
114641	4.720	<b>Ledger UH 125 Plus</b>
		<b>Ledger UH 150 Plus</b>

L	X
954	1000
1204	1250
1454	1500

**Note**

With length marking for easier identification.  
 One assembly point per side up to end of 2019,  
 with three UBL assembly points per side from 2020 onwards.

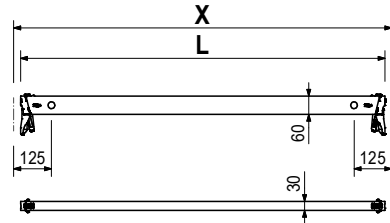
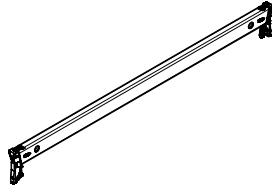

100014 2.470 **Base Standard UVB 24**

For assembling directly onto the base spindles.

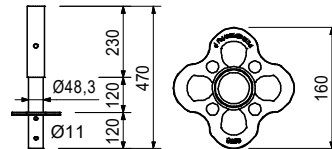
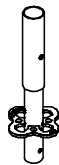

109630 4.240 **Spindle Head SRU**

For connecting SRU and SRZ steel walers on shoring systems.

**Note**

With captive quick jack nut.

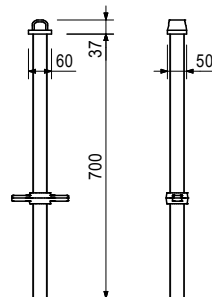
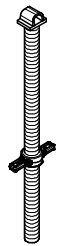

Accessories

104031	0.462	<b>Fitting pin Ø 21 x 120</b>
018060	0.014	<b>Cotter Pin 4/1, galv.</b>

100863 1.020 **Spindle Locking UJS**

Locks base spindles and section spindles Ø 38 mm in the vertical during moving procedures.

**Technical data**

Permissible load 1.5 kN.

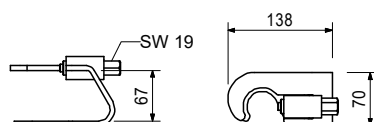

Article no. Weight kg

103945 1.840

### Scaffold Tube Connector FTF

For connecting scaffolding tubes to Steel Walers SRU.

### Complete with

2 pc. 105822 bolt  $\varnothing 20 \times 102$ , galv.  
2 pcs. 018060 Cotter Pin 4/1, galv.

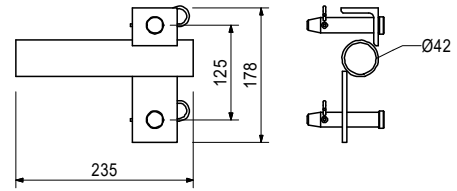
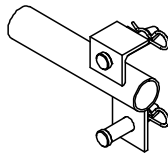

022016

1.290

### Brace Connector HDR

For connecting push-pull props and kicker braces to components with  $\varnothing 48$  mm.

### Complete with

1 pc. 027170 bolt  $\varnothing 16 \times 42$ , galv.  
1 pcs. 018060 Cotter Pin 4/1, galv.

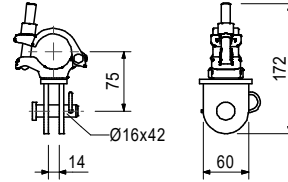
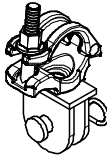

024180

0.126

### Compensation Washer 20, galv.

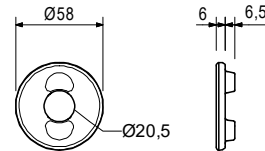

710219

0.184

### Bolt ISO 4014 M16 x 100-8.8, galv.

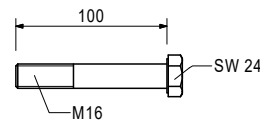
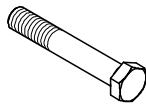

710229

0.033

### Nut ISO 4032 M16-8, galv.

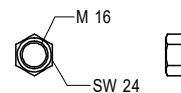

Article no. Weight kg

114299 9.520

## Guardrail Post GKB

To be clamped onto the reinforcement or fixed to built-in components.

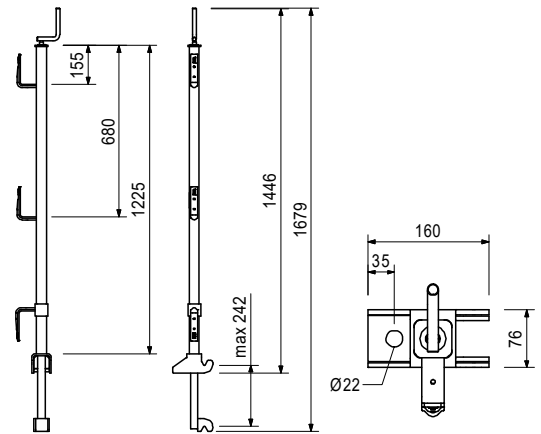
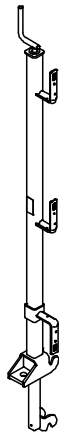

123970

0.047

## Screw-On Sleeve PERI M16/164

For temporary assembly of components on reinforced concrete slabs.

### Note

After concreting has taken place, it is inserted in the fresh concrete.

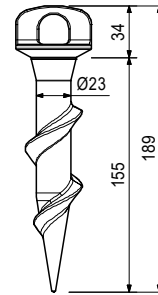
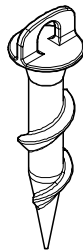

Accessories

123973

0.240

## Bolt ISO 4017 M16 x 130-8.8, galv.

030070

0.222

## Hex. Nut DW 15 AF 30/50, galv.

For anchoring with Tie Rod DW 15 and B 15.

### Technical data

Permissible load 90 kN.

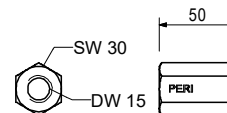



Article no. Weight kg

104131 3.940

### Guardrail Holder SRU/SRZ

For assembling guardrails with Steel Walers SRU and SRZ Profile U100 to U140.

### Complete with

2 pc. 105400 bolt  $\varnothing$  20 x 140, galv.  
2 pcs. 018060 Cotter Pin 4/1, galv.

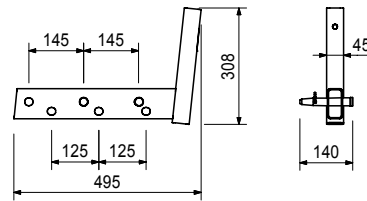
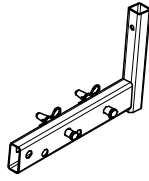

Accessories

116292 4.720  
061260 6.150

**Guardrail Post HSGP-2**  
**Guardrail Post SGP**

101290 5.670

### Guardrail Holder GT 24/VT 20

For assembling a guardrail onto Girder GT 24 and VT 20.

### Complete with

1 pc. 105400 bolt  $\varnothing$  20 x 140, galv.  
1 pcs. 018060 Cotter Pin 4/1, galv.

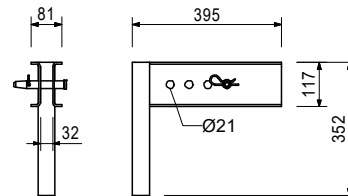
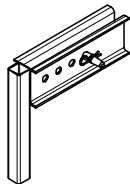

Accessories

116292 4.720  
061260 6.150

**Guardrail Post HSGP-2**  
**Guardrail Post SGP**

126088 4.390

### Guardrail Post Holder Multi

For fixing of an end guardrail post on Platform Beams GT 24, VT 20 or Timbers 80/160. Fixing the guardrail posts with bolts M20.

### Note

Suitable for  
Guardrail Post RCS 226 Article no.: 109720  
Guardrail Post RCS/SRU 184 Article no.: 114328  
Vertical scaffolding tubes  
Special Post QR 50 x 50

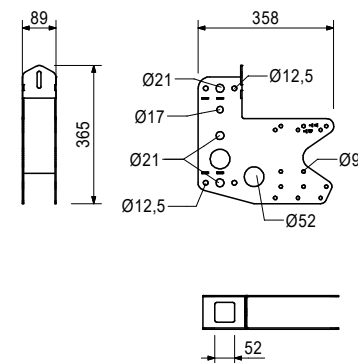
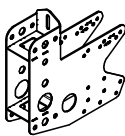

Accessories

710285 0.050  
024090 0.005  
024470 0.008

**Bolt ISO 4014 M8 x 100-8.8, galv.**  
**Nut ISO 4032 M8-8, galv.**  
**TSS-Torx 6 x 60, galv.**

Article no. Weight kg

114557 6.980

## Platform Beam SRU

For assembling a platform and guardrails for vertical Steel Walers SRU.

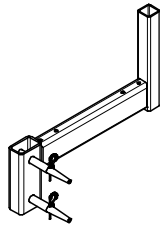

## Complete with

2 pcs. 104031 fitting pin  $\varnothing$  21 x 120  
2 pcs. 018060 Cotter Pin 4/1, galv.

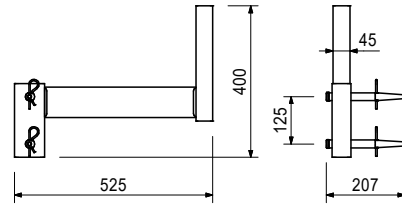

116292 4.720

Accessories

## Guardrail Post HSGP-2

116292 4.720

## Guardrail Post HSGP-2

As guardrails for various systems.

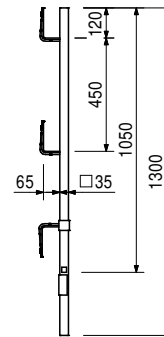

061260 6.150

## Guardrail Post SGP

As guardrails for various systems.

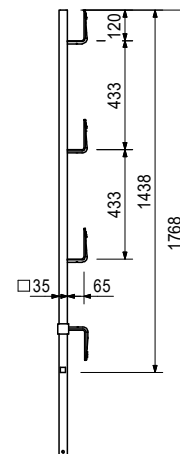

Article no. Weight kg

019040 6.480

## Guardrail Post PD 8

As guardrails for various systems. Screwed to the sub-structure.

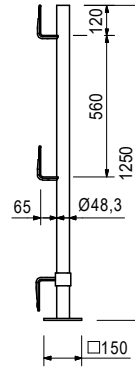
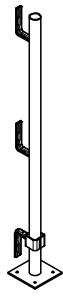

116363 0.089

## Spacer RCS 184

Compensation between Angle Connector RCS/SRU and Guardrail Post RCS 184.



114328 16.600

## Guardrail Post RCS/SRU 184

For assembling guardrails onto Platform Beam RCS/SRU or the Guardrail Post Holder Multi.

### Complete with

2 pc. 114727 bolt ISO 4017 M20 x 100-8.8, galv.  
2 pc. 781053 nut ISO 7040 M20-8, galv.

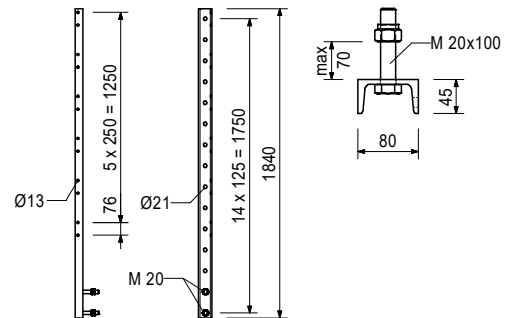

110296 0.220

### Accessories

**Clamp A64 DIN 3570 M12, galv.**

710330 0.017

**Nut ISO 4032 M12-8, galv.**

710709 0.036

**F.H. Bolt DIN 603 M8 x 65 MU, galv.**

780354 0.002

**Washer ISO 7089 200 HV, A 8, galv.**

057345 0.010

**Plain washer 9 DIN 434, galv.**

Article no. Weight kg

109720 26.600

### Guardrail Post RCS 226

For assembling guardrails onto the main platform for RCS Formwork Scaffolds or on Guardrail Post Holder Multi.

### Complete with

2 pc. 104477 bolt ISO 4014 M20 x 120-8.8, galv.  
2 pc. 781053 nut ISO 7040 M20-8, galv.

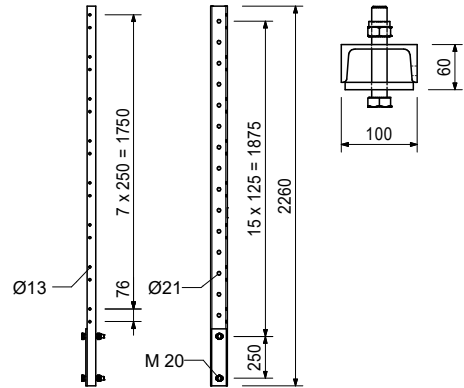

### Accessories

110296 0.220  
710330 0.017  
710709 0.036  
780354 0.002  
057345 0.010

**Clamp A64 DIN 3570 M12, galv.**  
**Nut ISO 4032 M12-8, galv.**  
**F.H. Bolt DIN 603 M8 x 65 MU, galv.**  
**Washer ISO 7089 200 HV, A 8, galv.**  
**Plain washer 9 DIN 434, galv.**

109721 40.700  
109773 67.900

### Guardrail Posts RCS Guardrail Post RCS 384 Guardrail Post RCS 509

For assembling guardrails onto the intermediate and finishing platforms for RCS Formwork Scaffolding or used as horizontal strut for bracing.

### Complete with

1 pc. 104477 bolt ISO 4014 M20 x 120-8.8, galv.  
1 pc. 781053 nut ISO 7040 M20-8, galv.

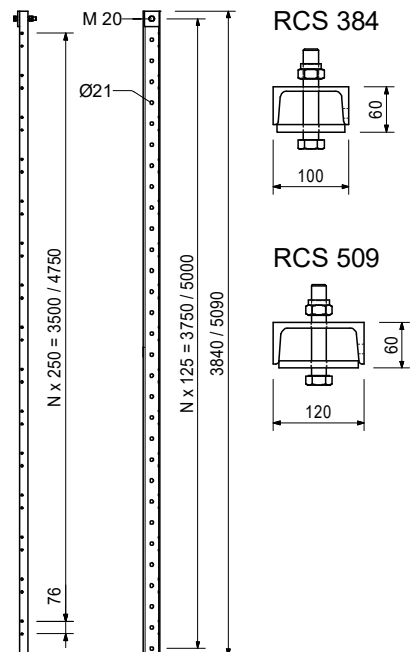

Article no. Weight kg

126495 24.200

## Guardrail Post RCS- MP

For fixing the lateral protection to Landing Platforms RCS-MP with the Horizontal Climbing Rail RCS.

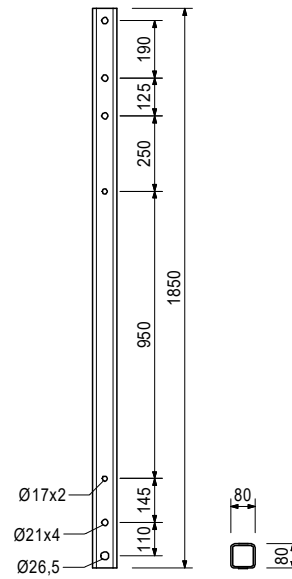

104477 0.300  
781053 0.065  
104031 0.462  
018060 0.014

Accessories

**Bolt ISO 4014 M20 x 120-8.8, galv.**

**Nut ISO 7040 M20-8, galv.**

**Fitting pin Ø 21 x 120**

**Cotter Pin 4/1, galv.**

110296 0.220

## Clamp A64 DIN 3570 M12, galv.

For assembling scaffolding tubes to Guardrail Posts RCS.

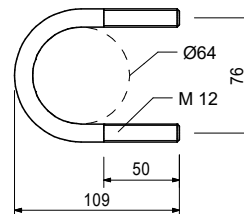
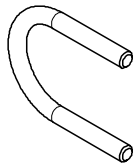

710330 0.017

Accessories

**Nut ISO 4032 M12-8, galv.**

Article no. Weight kg

Article no.	Weight kg	Steel Waler Universal SRU	L
103868	18.100	Steel Waler Universal SRU U120, L = 0.72 m	722
103871	24.200	Steel Waler Universal SRU U120, L = 0.97 m	972
123809	29.500	Steel Waler Universal SRU U120, L = 1.17 m	1172
103874	30.900	Steel Waler Universal SRU U120, L = 1.22 m	1222
103877	38.100	Steel Waler Universal SRU U120, L = 1.47 m	1472
103886	44.700	Steel Waler Universal SRU U120, L = 1.72 m	1722
125088	46.100	Steel Waler Universal SRU U120, L = 1.77 m	1772
103889	52.000	Steel Waler Universal SRU U120, L = 1.97 m	1972
103898	58.600	Steel Waler Universal SRU U120, L = 2.22 m	2222
123812	63.000	Steel Waler Universal SRU U120, L = 2.37 m	2372
103892	65.600	Steel Waler Universal SRU U120, L = 2.47 m	2472
103929	72.000	Steel Waler Universal SRU U120, L = 2.72 m	2722
103903	81.000	Steel Waler Universal SRU U120, L = 2.97 m	2972
103906	92.600	Steel Waler Universal SRU U120, L = 3.47 m	3472
103915	106.000	Steel Waler Universal SRU U120, L = 3.97 m	3972
103918	119.000	Steel Waler Universal SRU U120, L = 4.47 m	4472
103922	135.000	Steel Waler Universal SRU U120, L = 4.97 m	4972
103925	146.000	Steel Waler Universal SRU U120, L = 5.47 m	5472
103928	159.000	Steel Waler Universal SRU U120, L = 5.97 m	5972

Universal Steel Waler Profile U120 used as waling for girder wall formwork and for various special applications. With adjustable spacers.

**Note**

Permissible load: see PERI Design Tables!

**Technical data**

SRU 120  $W_y = 121.4 \text{ cm}^3$ ,  $I_y = 728 \text{ cm}^4$ .

SRU 140  $W_y = 172.8 \text{ cm}^3$ ,  $I_y = 1210 \text{ cm}^4$ .

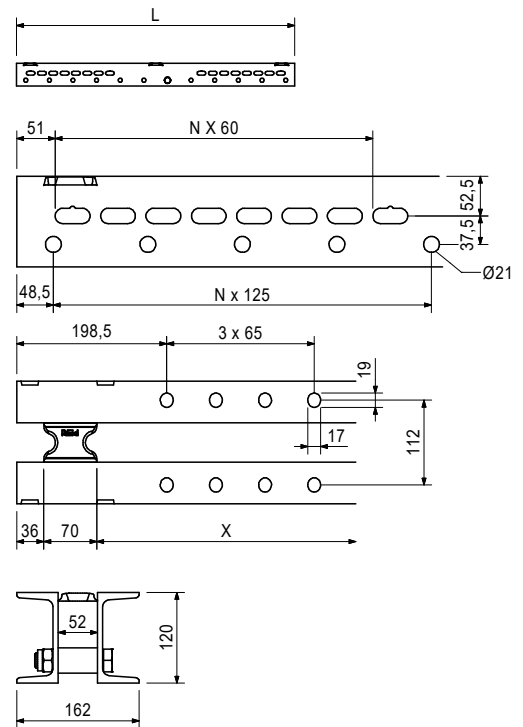
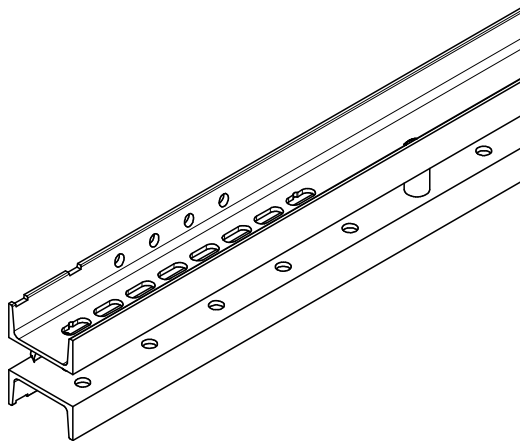

Article no. Weight kg

104027 7.610

### Extension VARIO 24 U120

For assembling on Steel Waler SRU.

### Complete with

4 pc. 710252 bolt ISO 4017 M16 x 50-8.8, galv.

4 pc. 070890 nut ISO 7040 M16-8, galv.

4 pc. 710880 Washer DIN 434 18, galv.

### Technical data

U120:  $W_y = 121.4 \text{ cm}^3$ ,  $I_y = 728 \text{ cm}^4$ .

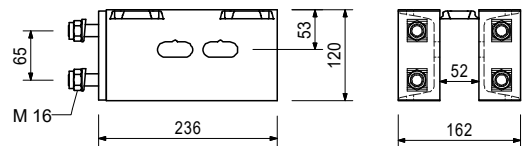
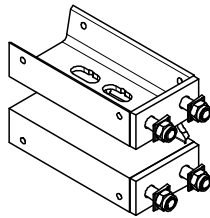

111035	12.000	<b>Heavy-Duty Spindles SLS</b>
101773	15.300	<b>Heavy-Duty Spindle SLS 40/80</b>
101774	18.300	<b>Heavy-Duty Spindle SLS 80/140</b>
101776	24.900	<b>Heavy-Duty Spindle SLS 100/180</b>
101778	32.300	<b>Heavy-Duty Spindle SLS 140/240</b>
101779	38.500	<b>Heavy-Duty Spindle SLS 200/300</b>
109726	44.800	<b>Heavy-Duty Spindle SLS 260/360</b>
109785	51.000	<b>Heavy-Duty Spindle SLS 320/420</b>
		<b>Heavy-Duty Spindle SLS 380/480</b>

Used as adjustable spindle for truss beams made of Steel Walers SRU and Climbing Rails RCS.

A	min. L	max. L
344	400	800
746	800	1,400
946	1,000	1,800
1,346	1,400	2,400
1,944	2,000	3,000
2,544	2,600	3,600
3,144	3,200	4,200
3,744	3,800	4,800

### Note

See PERI Design Tables for permissible load.

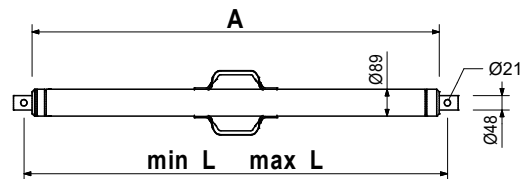
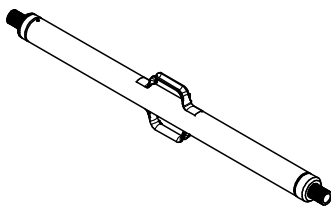

104031	0.462	<b>Fitting pin Ø 21 x 120</b>
018060	0.014	<b>Cotter Pin 4/1, galv.</b>
110477	3.990	<b>Spindle Adaptor SLS/RCS</b>

### Accessories

**Fitting pin Ø 21 x 120**  
**Cotter Pin 4/1, galv.**  
**Spindle Adaptor SLS/RCS**

110477	3.990	<b>Spindle Adapter SLS/RCS</b>
--------	-------	--------------------------------

For connecting Heavy-Duty Spindles SLS to the Climbing Rail RCS.

### Complete with

1 pcs. 104031 fitting pin Ø 21 x 120

1 pcs. 018060 Cotter Pin 4/1, galv.

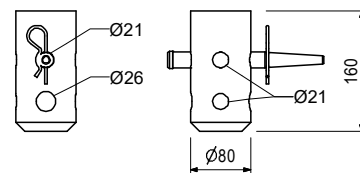
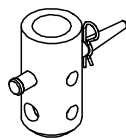

104031	0.462	<b>Fitting pin Ø 21 x 120</b>
018060	0.014	<b>Cotter Pin 4/1, galv.</b>
111567	0.729	<b>Fitting pin Ø 26 x 120</b>
022230	0.033	<b>Cotter pin 5/1, galv.</b>

### Accessories

**Fitting pin Ø 21 x 120**  
**Cotter Pin 4/1, galv.**  
**Fitting pin Ø 26 x 120**  
**Cotter pin 5/1, galv.**

# VGB Parapet Track

Article no. Weight kg

104031 0.462

## Fitting pin $\varnothing 21 \times 120$

For various connections.

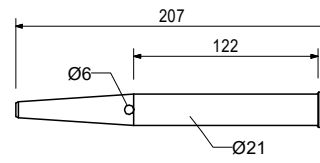
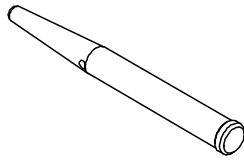

018060 0.014

Accessories

## Cotter Pin 4/1, galv.

018060 0.014

## Cotter Pin 4/1, galv.





Article no. Weight kg

Article no.	Weight kg	Girder GT 24
075100	5.300	Girder GT 24, l = 0.90 m
075120	7.100	Girder GT 24, l = 1.20 m
075150	8.900	Girder GT 24, l = 1.50 m
075180	10.600	Girder GT 24, l = 1.80 m
075210	12.400	Girder GT 24, l = 2.10 m
075240	14.200	Girder GT 24, l = 2.40 m
075270	15.900	Girder GT 24, l = 2.70 m
075300	17.700	Girder GT 24, l = 3.00 m
075330	19.500	Girder GT 24, l = 3.30 m
075360	21.200	Girder GT 24, l = 3.60 m
075390	23.000	Girder GT 24, l = 3.90 m
075420	24.800	Girder GT 24, l = 4.20 m
075450	26.600	Girder GT 24, l = 4.50 m
075480	28.300	Girder GT 24, l = 4.80 m
075510	30.100	Girder GT 24, l = 5.10 m
075540	31.900	Girder GT 24, l = 5.40 m
075570	33.600	Girder GT 24, l = 5.70 m
075600	35.400	Girder GT 24, l = 6.00 m

L
918
1214
1510
1806
2102
2398
2694
2990
3286
3582
3878
4174
4470
4766
5062
5358
5654
5950

**Note**

Special lengths possible with 078xxx numbers.

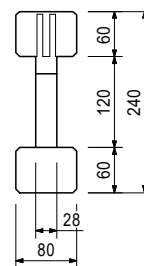
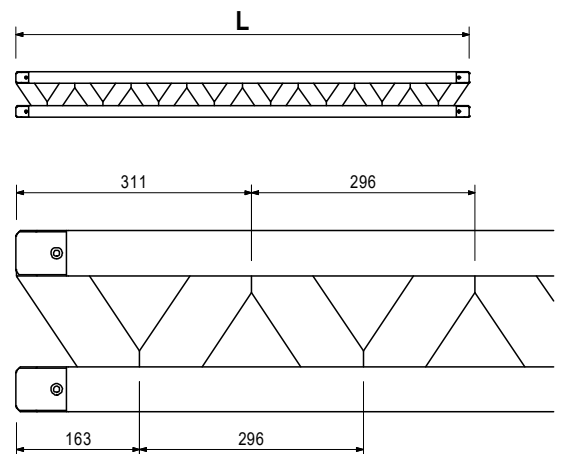
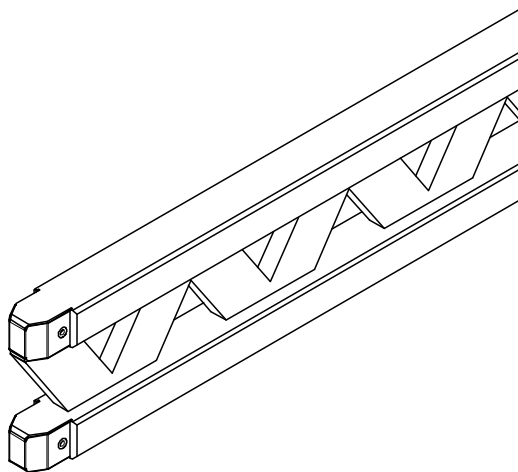

Article no. Weight kg

Article no.	Weight kg	Girder VT 20K with Steel Cap	L
074990	8.230	<b>Girder VT 20K, l = 1.45 m</b>	1447
074905	12.010	<b>Girder VT 20K, l = 2.15 m</b>	2152
074910	13.630	<b>Girder VT 20K, l = 2.45 m</b>	2452
074890	14.710	<b>Girder VT 20K, l = 2.65 m</b>	2652
074920	16.060	<b>Girder VT 20K, l = 2.90 m</b>	2902
074930	18.220	<b>Girder VT 20K, l = 3.30 m</b>	3292
074940	19.840	<b>Girder VT 20K, l = 3.60 m</b>	3592
074950	21.460	<b>Girder VT 20K, l = 3.90 m</b>	3892
074960	24.700	<b>Girder VT 20K, l = 4.50 m</b>	4492
074970	26.860	<b>Girder VT 20K, l = 4.90 m</b>	4902
074980	32.260	<b>Girder VT 20K, l = 5.90 m</b>	5902
074900	0.000	<b>Cutting Cost VT Girder</b>	

Universal formwork girder made of wood.

### Note

The girder fulfils all requirements of DIN EN 13377 Class P20 (Declaration of Conformity).

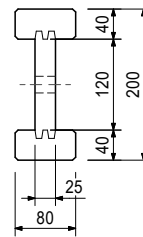
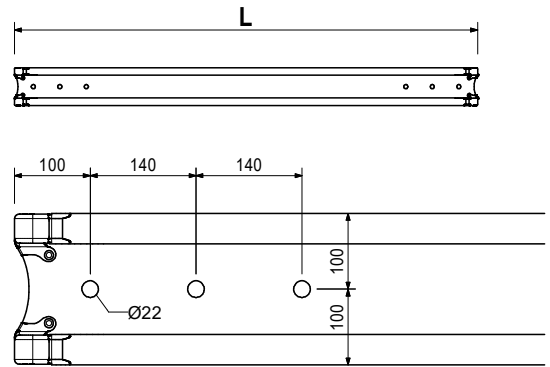
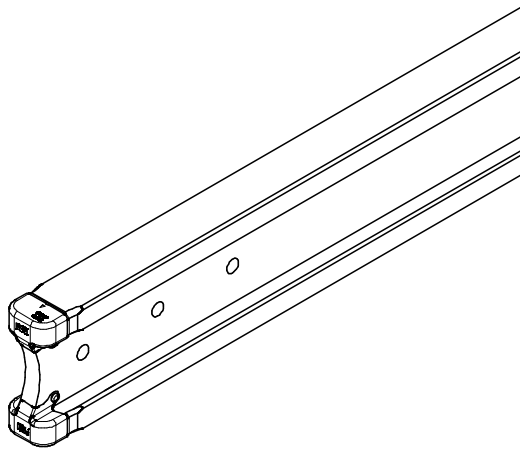

024070	0.691	<b>Hook Strap HB 24-100/120, galv.</b> For fixing Girders GT 24 to Steel Walers SRZ, SRU and BR; U100 – U120.
--------	-------	--

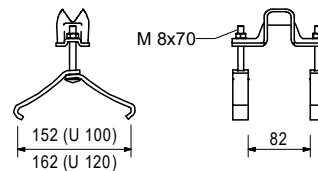
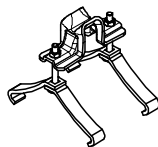

Article no. Weight kg

024080 0.735

### Hook Strap HB 24-140/160, galv.

For fixing Girders GT 24 to Steel Walers SRZ, SRU and BR; U140 – U160.

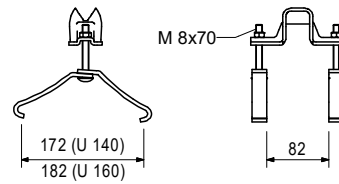
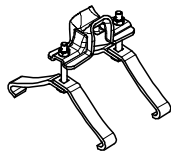

104931 0.839  
103845 0.893

### Hook Straps Uni HBU Hook Strap Uni HBU 20-24 Hook Strap Uni HBU 24-28

For fixing Girders GT 24 or VT 20 to Steel Walers SRZ or SRU profile U100 – U140.

#### Note

The girders can be mounted at right-angles or diagonally to the steel walers and also outside of the nodes.

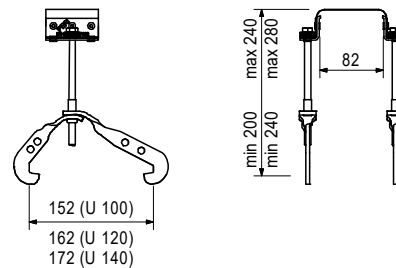
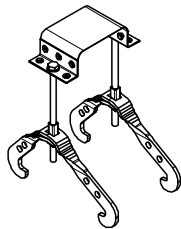

024540 0.005

Accessories

### TSS-Torx 6 x 40, galv.

104930 0.887  
104096 0.912

### Hook Straps Uni Double DBUD Hook Strap Uni Double HBUD 20-24 Hook Strap Uni Double HBUD 24-28

For fixing 2 Girders GT 24 or VT 20 to Steel Walers SRZ or SRU profile U100 – U140.

#### Note

The girders can be mounted at right-angles or diagonally to the steel walers and also outside of the nodes.

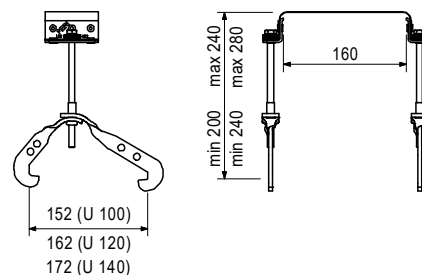
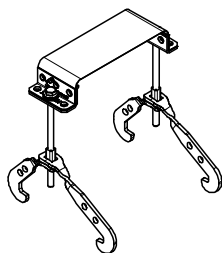

Article no. Weight kg

024860 0.616

## Hook Strap HB 24 Cross Strap 150, galv.

For fixing Girders GT 24 to Steel Walers SRZ, SRU and BR: U100 - U120 outside of the girder nodes and squared timber.

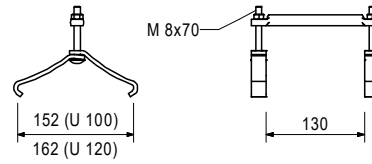
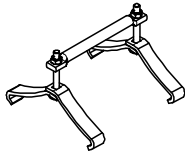

024600 0.907

## Girder Claw HB

For fixing the Edge Beam GT 24 to the Steel Walers SRZ and SRU, profile U100 – U120.

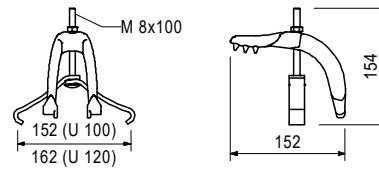
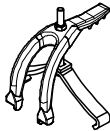

024640 0.923

## Quick Str. Hook Strap 24-100/140, galv.

For fixing Girders GT 24 to Steel Walers SRZ, SRU, Profile U100 – U140 outside of the girder nodes.

### Note

Girders fixed in position with the quick strap must be specially screwed to the formlining when using crane lifting units.

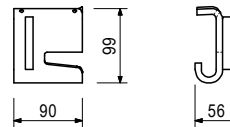
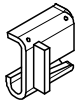

024630 0.742

## Fix Strap U100 – U120, galv.

For fixing the Girders GT 24 in the VARIO corner.

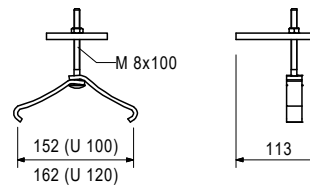
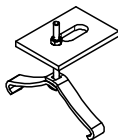

Article no. Weight kg

Article no.	Weight kg	Description
030030	1.440	<b>Tie Rod DW 15</b>
030050	0.000	<b>Tie Rod DW 15, special length</b>
030005	0.720	<b>Cutting costs DW 15, B 15</b>
030010	1.230	<b>Tie Rod DW 15, L = 0.50 m</b>
030480	1.440	<b>Tie Rod DW 15, L = 1.00 m</b>
030490	1.730	<b>Tie Rod DW 15, L = 1.20 m</b>
030170	2.160	<b>Tie Rod DW 15, L = 1.50 m</b>
030020	2.450	<b>Tie Rod DW 15, L = 1.70 m</b>
030180	2.880	<b>Tie Rod DW 15, L = 2.00 m</b>
030710	3.600	<b>Tie Rod DW 15, L = 2.50 m</b>
030720	4.320	<b>Tie Rod DW 15, L = 3.00 m</b>
030730	5.040	<b>Tie Rod DW 15, L = 3.50 m</b>
030160	8.640	<b>Tie Rod DW 15, L = 6.00 m</b>

**Note**

Non-weldable! Observe the permissions!

**Technical data**

Permissible tension force 90 kN.

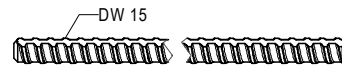
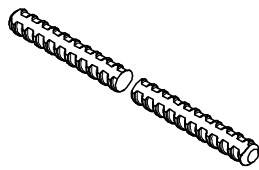

030740	1.550	<b>Tie Rod B 15</b>
030050	0.000	<b>Tie Rod B 15, special length</b>
030150	0.420	<b>Cutting costs DW 15, B 15</b>
		<b>Tie Rod B 15, L = 0.30 m</b>

**Note**

Weldable! Observe the permissions!

**Technical data**

Permissible tension force 82 kN.

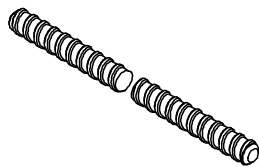

Article no.	Weight kg	Description
026415	3.550	<b>Steel scaffolding tube Ø 48.3</b>
026417	0.000	<b>Steel scaffolding tube Ø 48.3 x 3.2, special length</b>
026411	3.550	<b>Cutting costs for scaffolding tubes</b>
026412	7.100	<b>Steel scaffolding tube Ø 48.3 x 3.2, l = 1.0 m</b>
125976	8.900	<b>Steel scaffolding tube Ø 48.3 x 3.2, l = 2.0 m</b>
026413	10.650	<b>Steel scaffolding tube Ø 48.3 x 3.2, l = 2.5 m</b>
114287	12.500	<b>Steel scaffolding tube Ø 48.3 x 3.2, l = 3.0 m</b>
026414	14.200	<b>Steel scaffolding tube Ø 48.3 x 3.2, l = 3.5 m</b>
026419	17.750	<b>Steel scaffolding tube Ø 48.3 x 3.2, l = 4.0 m</b>
026418	21.600	<b>Steel scaffolding tube Ø 48.3 x 3.2, l = 5.0 m</b>
		<b>Steel scaffolding tube Ø 48.3 x 3.2, l = 6.0 m</b>

**L**

1000

2000

2500

3000

3500

4000

5000

6000

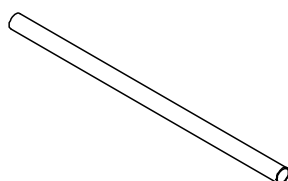

Article no. Weight kg

017010 1.400

**Swivel Coupling AF 48/48, galv.**  
For scaffolding tubes  $\varnothing$  48 mm.

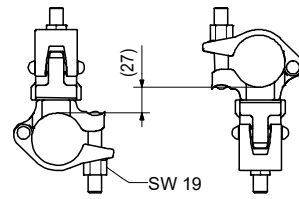
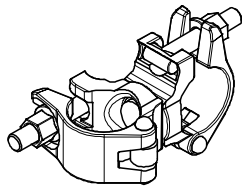

017020 1.120

**Standard Coupler RA 48/48, galv.**  
For scaffolding tubes  $\varnothing$  48 mm.

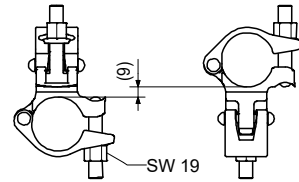
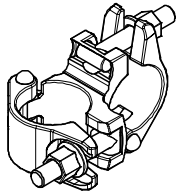



The optimal system for  
all projects and every  
requirement



Wall formwork



Column formwork



Slab formwork



Climbing systems

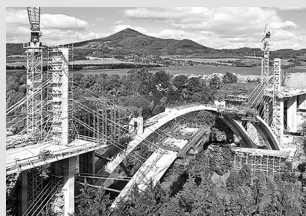

Bridge formwork



Tunnel formwork



Shoring



Working scaffolds construction



Working scaffolds facade



Working scaffolds industry



Means of access



Safety scaffolds



Safety systems



System-independent accessories



Services



**PERI Norge AS**  
Forskaling Stillas Engineering  
Orhusveien 6  
3070 Sande i Vestfold  
Norge  
Tel. +47 32 20 49 40  
info@peri.no  
www.peri.no

