

## PERI Stopend Systems

Article no. 065039	Stopend Sleeve DW 15
Article no. 065062	Formwork Bracket-2
Article no. 065063	Slab Stopend Bar 105
Article no. 065045	Wall Clamp 55
Article no. 065076	Wall Clamp 75
Article no. 065046	Wall Clamp 105

Instructions for Assembly and Use – Standard Configuration – Version 1.0



<b>Overview</b>	
Main components	3
Key	4
<b>Introduction</b>	
Target groups	5
Additional technical documentation	5
Intended use	6
Instructions for Use	6
Cleaning and maintenance instructions	7
<b>Safety instructions</b>	
Cross-system	8
System-specific	10
Storage and transportation	10
Component overview	11
<b>Components</b>	
A1 Stopend Sleeve DW 15	12
Overview	12
Assembly	13
A2 Formwork Bracket-2	14
Overview	14
Assembly	15
A3 Slab Stopend Bar 105	16
Overview	16
Assembly	17
A4 Wall Clamp 55, 75, 105	18
Overview	18
Assembling beam formwork	19
Assembling foundation formwork	19
<b>Program overview</b>	
Shuttering Solutions	20



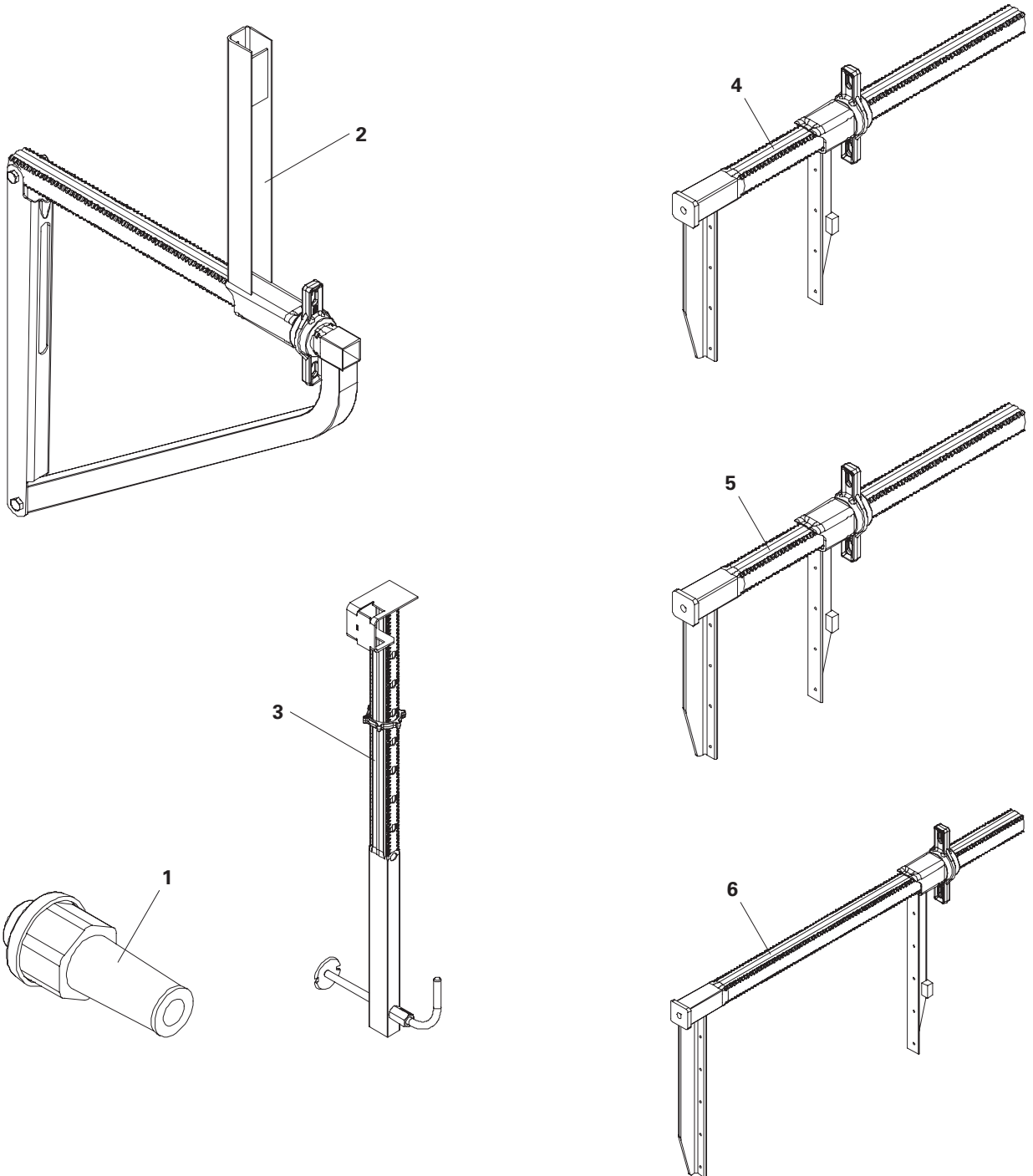









## Main components





- 1 Stopend Sleeve DW 15
- 2 Formwork Bracket-2
- 3 Slab Stopend Bar 105
- 4 Wall Clamp 55
- 5 Wall Clamp 75
- 6 Wall Clamp 105

## Key

### Pictogram | Definition

-  Danger/Warning/Caution
-  Note
-  To be complied with
-  Load-bearing point
-  Visual inspection
-  Tip
-  Incorrect use
-  Safety helmet
-  Safety shoes
-  Safety gloves
-  Safety goggles
-  Personal protective equipment to prevent falling from a height (PPE)

### Arrows

-  Arrow representing an action
-  Arrow representing a reaction of an action\*
-  Arrow representing forces

\* If not identical to the action arrow.

### Safety instruction categories

The safety instructions alert site personnel to the risks involved and provide information on how to avoid these risks. Safety instructions are featured at the beginning of the section or ahead of the instructions, and are highlighted as follows:

#### **Danger**

This sign indicates an extremely hazardous situation which, if not avoided, will result in death or serious, irreversible injury.

#### **Warning**

This sign indicates a hazardous situation which, if not avoided, could result in death or serious, irreversible injury.

#### **Caution**

This sign indicates a hazardous situation which, if not avoided, could result in minor or moderate injury.

#### **Note**

This sign indicates situations in which failure to observe the information can result in material damage.

### Format of the safety instructions

#### **Signal word**

Type and source of hazard!  
Consequences of non-compliance.  
⇒ Preventative measures.

### Dimensions

Dimensions are usually given in cm. Other measurement units, e.g. m, are shown in the illustrations.

### Conventions

- Instructions are numbered with: 1. ...., 2. ...., 3. ....
- The result of an instruction is shown by: →
- Position numbers are clearly provided for the individual components and are given in the drawing, e.g. **1**, in the text in brackets, for example **(1)**.
- Multiple position numbers, i.e. alternative components, are represented with a slash: e.g. **1/2**.

### Notes on illustrations

The illustration on the front cover of these instructions is understood to be a system representation only. The assembly steps presented in these Instructions for Assembly and Use are shown in the form of examples with only one component size. They are valid for all component sizes contained in the standard configuration.

To facilitate understanding, detailed illustrations are sometimes incomplete. The safety installations which have possibly not been shown in these detailed illustrations must nevertheless be available.

## Target groups

### Contractors

These Instructions for Assembly and Use are designed for contractors who either

- assemble, modify and dismantle formwork systems, or
- use them, e.g. for concreting, or
- allow them to be used for other operations, e.g. carpentry or electrical work.

### Competent person

(Construction Site Coordinator)

The Safety and Health Protection Coordinator\*

- is appointed by the client,
- must identify potential hazards during the planning phase,
- determines measures that provide protection against risks,
- creates a safety and health protection plan,
- coordinates the protective measures for the contractor and site personnel so that they do not endanger each other,
- monitors compliance with the protective measures.

### Competent persons qualified to carry out inspections

Due to the specialist knowledge gained from professional training, work experience and recent professional activity, the competent person qualified to carry out inspections has a reliable understanding of safety-related issues and can carry out inspections correctly. Depending on the complexity of the inspection to be undertaken, e.g. scope of testing, type of testing or the use of certain measuring devices, a range of specialist knowledge is necessary.

### Qualified personnel

Formwork systems may only be assembled, modified or dismantled by personnel who are suitably qualified to do so. Qualified personnel must have completed a course of training\*\* in the work to be performed, covering the following points at least:

- Explanation of the plan for the assembly, modification or dismantling of the formwork in an understandable form and language.
- Description of the measures for assembling, modifying or dismantling the formwork.

- Naming of the preventive measures to be taken to avoid the risk of persons and objects falling.
- Naming of the safety precautions in the event of changing weather conditions which could adversely affect the safety of the formwork system as well as the persons concerned.
- Details regarding permissible loads.
- Description of all other risks and dangers associated with assembly, modification or dismantling operations.



- **In other countries, ensure that the relevant national guidelines and regulations in the respective current version are complied with!**
- **If no country-specific regulations are available, it is recommended to proceed according to German guidelines and regulations.**
- **A competent person must be present on site during formwork operations.**

\* Valid in Germany: Regulations for Occupational Health and Safety on Construction Sites 30 (RAB 30).

\*\* Instructions are given by the contractor themselves or a competent person selected by them.

---

## Additional technical documentation

- Design Tables 2015 – Formwork and Shoring
- Component catalogue
  - System-independent accessories and components for day-to-day requirements on the construction site

## Intended use

### Product description

PERI products have been designed for exclusive use in the industrial and commercial sectors only by suitably trained personnel.

The Formwork Bracket-2 is used for setting slab edges up to a slab thickness of 30 cm and for forming a slab overhang of max. 40 cm.

The Slab Stopend Bar 105 is used for setting slab edges up to a slab thickness of 50 cm.

The wall clamps with clamping widths of 55 cm, 75 cm and 105 cm are used for forming strip foundations, low beams and ring beam formwork.

### Features

- With the Formwork Bracket-2 and the Slab Stopend Bar, the Guardrail Post HSGP-2 can be mounted as a guardrail.
- Both systems are mounted on the Stopend Sleeve DW 15 with Tie Rod B 15 and Wingnut Counterplate DW 15.

### Technical data

Max. working wind = 0.2 kN/m<sup>2</sup>

Formwork Bracket-2:

- Max. slab thickness: 30 cm
- Max. cantilever: 45 cm

Slab Stopend Bar 105:

- Max. slab thickness: 50 cm

Wall Clamp 55:

- Max. clamping width: 55 cm
- Max. concreting height: 30 cm

Wall Clamp 75:

- Max. clamping width: 75 cm
- Max. concreting height: 40 cm

Wall Clamp 105:

- Max. clamping width: 105 cm
- Max. concreting height: 50 cm

---

## Instructions for Use

Use in a way not intended, deviating from the standard configuration or the intended use according to the Instructions for Assembly and Use, represents a misapplication with a potential safety risk, e.g. risk of falling.

Only PERI original components may be used. The use of other products and spare parts is not allowed.

Changes to PERI components are not permitted.

The system described in these Instructions for Assembly and Use may contain patent-protected components.

## Cleaning and maintenance instructions

In order to maintain the value and operational readiness of the formwork materials over the long term, clean the panels after each use.

Some repair work may also be inevitable due to the tough working conditions.

The following points should help to keep cleaning and maintenance costs as low as possible.

Spray the formwork on both sides with concrete release agent before each use; this facilitates easier and faster cleaning of the formwork. Spray the concrete release agent very thinly and evenly!

Spray the rear side of the formwork with water immediately after concreting; this avoids any time-consuming and costly cleaning operations.

When used continuously, spray the panel formlining with concrete release agent immediately after striking; then clean by means of a scraper, brush or rubber lip scraper.

Important: do not clean formlining made of plywood with high-pressure equipment. This could result in the formlining being damaged.

Fix box-outs and mounting parts with double-headed nails; as a result, the nails can easily be removed later, and damage to the formlining is largely avoided.

Close all unused tie holes with plugs; this eliminates any subsequent cleaning or repair work.

Tie holes accidentally blocked with concrete are cleared by means of a steel pin from the formlining side.

When placing bundles of reinforcement bars or other heavy objects on horizontally stored formwork elements, suitable support, e.g. square timbers, is to be used: this prevents impressions and damage to the formlining to a large extent.

Internal concrete vibrators should be fitted with rubber caps if possible; as a result, any damage to the formlining is reduced if the vibrator is accidentally inserted between the reinforcement and formlining.

Never clean powder-coated components, e.g. elements and accessories, with a steel brush or hard metal scraper; this ensures that the powder-coating remains intact.

Use spacers for reinforcement with large-sized supports or extensive areas of support; this largely avoids impressions being formed in the formlining when under load.

Mechanical components, e.g. spindles or gear mechanisms, must be cleaned of dirt or concrete residue before and after use, and then greased with a suitable lubricant.

Provide suitable support for the components during cleaning so that no unintentional change in their position is possible.

Do not clean components suspended on crane lifting gear.

## Cross-system



### **Safety instructions apply to all service life phases of the system.**

#### **General**

The contractor must ensure that the Instructions for Assembly and Use supplied by PERI are available at all times and understood by the site personnel.

These Instructions for Assembly and Use can be used as the basis for creating a risk assessment. The risk assessment is compiled by the contractor. However, these Instructions for Assembly and Use do not replace the risk assessment!

Refer to and comply with the safety instructions and permissible loads.

For the application and inspection of PERI products, the current safety regulations and guidelines valid in the respective countries must be observed.

Materials and working areas are to be inspected before each use and assembly, for:

- damage,
- stability and
- functional correctness.

Damaged components must be exchanged immediately on site and may no longer be used.

Safety components are to be removed only when they are no longer required.

When on slab formwork, scaffolds and working platforms:

- do not jump,
- do not run,
- do not drop anything from or onto it.

Components provided by the contractor must comply with the characteristics stipulated in these Instructions for Assembly and Use and all applicable laws and standards. Unless otherwise indicated, the following applies in particular:

- timber components: strength class C24 for solid wood according to EN 338.
- scaffold tubes: galvanised steel tubing with minimum dimensions  $\varnothing 48.3 \times 3.2$  mm according to EN 12811-1:2003 4.2.1.2.
- scaffold tube couplings according to EN 74-1 and EN 74-2.

Deviations from the standard configuration are only permitted after a further risk assessment has been carried out by the contractor.

Appropriate measures for working and operational safety, as well as stability, are defined on the basis of this risk assessment.

Corresponding proof of stability can be provided by PERI on request, if the risk assessment and resulting measures to be implemented are made available.

Before and after exceptional occurrences that may have an adverse effect on the safety of the formwork system, the contractor must immediately

- produce another risk assessment and make use of its results to take suitable steps to guarantee the stability of the formwork system,
- arrange for an extraordinary inspection to be carried out by a competent person qualified to do so. The aim of this inspection is to identify and rectify any damage in good time in order to guarantee safe use of the formwork system.

Exceptional events could be:

- accidents,
- longer periods of non-use,
- natural events, e.g. heavy rainfall, icing, heavy snowfall, storms or earthquakes.



## Assembly, modification and dismantling work

Assembly, modification or dismantling of formwork systems may only be carried out by qualified persons under the supervision of a competent person. The qualified personnel must have received appropriate training for the work to be carried out with regard to specific risks and dangers.

On the basis of the risk assessment and the Instructions for Assembly and Use, the contractor must create installation instructions to ensure safe assembly, modification and dismantling of the formwork system.



The contractor must ensure that the personal protective equipment required for the assembly, modification or dismantling of the formwork system, e.g.

- safety helmet,
- safety shoes,
- safety gloves,
- safety goggles,

is available and used as intended.



If personal protective equipment against falling from a height (PPE) is required or specified in local regulations, the contractor must determine appropriate attachment points on the basis of the risk assessment.

The PPE against falling to be used is determined by the contractor.

The contractor must

- provide safe working areas for site personnel, which are to be reached through the provision of safe access ways. Danger zones must be cordoned off and clearly marked.
- ensure stability during all stages of construction, in particular during assembly, modification and dismantling operations.
- ensure and demonstrate that all loads that occur are safely transferred.

## Use

Every contractor who uses or allows the formwork systems to be used, is responsible for ensuring that the equipment is in good condition.

If the formwork system is used successively or at the same time by several contractors, the health and safety coordinator must point out any possible mutual hazards and all work must be then coordinated.

## System-specific

Strike components only when the concrete has sufficiently hardened and the person in charge has given the go-ahead for striking to take place.

Anchoring is to take place only if the anchorage has sufficient concrete strength.

During striking, do not tear off the formwork units with the crane.

When storing heavy items on the formwork, the load-bearing capacity must be taken into consideration.

Only use Slab Stopend Bar 105, Formwork Bracket-2 and Wall Clamp 55 / 75 / 105 up to a height of 30 m with max. working wind of 0.2 kN/m<sup>2</sup>.

Always secure guardrail boards to the Guardrail Post HSGP-2 with 2x screws 5 x 20.

## Storage and transportation

Store and transport components in such a way that no unintentional change in their position is possible. Detach lifting accessories and slings from the lowered components only if they are in a stable position and no unintentional change is possible.

Do not drop the components.

Use PERI lifting accessories and slings and only those load-bearing points provided on the component.

During the relocation procedure

- ensure that components are picked up and set down so that unintentional falling over, falling apart, sliding, falling down or rolling is avoided.
- no persons are allowed to remain under the suspended load.

The access areas on the construction site must be free of obstacles and tripping hazards, as well as being slip-resistant.

For transportation, the base must have sufficient load-bearing capacity.

Use original PERI storage and transport systems, e.g. crate pallets, pallets or stacking devices.

Pos. no.	Designation	Article no.
1	Stopend Sleeve DW 15	065039
2	Formwork Bracket-2	065062
3	Slab Stopend Bar 105	065063
4	Wall Clamp 55	065045
5	Wall Clamp 75	065076
6	Wall Clamp 105	065046
7	Tie Rod B 15, L = 0.30 m	030150
8	Wingnut Counterplate DW 15	030110
9	TSS-Torx 6 x 60	024540
10	Guardrail Post HSGP-2	116292
11	Square timber	–
12	Formlining	–
13	Double-head nail L = 65 mm	018280
14	Screw 5 x 20	–

Tab. 01

## Overview



- Anchoring for PERI stopend systems.
- Supplied with nail plugs.

**Permissible tie tensile force Z [kN] depending on the concrete strength.  
Concrete strength class C20/25 to C50/60.**

Required concrete strength $f_{ck,cube}$ [N/mm <sup>2</sup> ]	10	15	20	25	30
Tie tensile force Z [kN]	6.3	8.6	10.1	10.4	10.7

Boundary conditions:

- Centre distance  $\geq 300$  mm
- Edge distance  $\geq 150$  mm (parallel and transverse to the direction of the load)
- Component thickness  $\geq 200$  mm

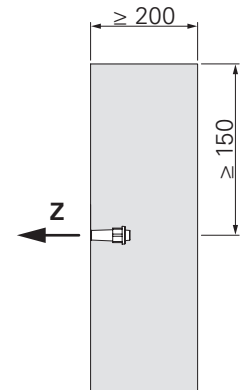

Fig. A1.01

## Assembly



- The Stopend Sleeve DW 15 is a lost part and remains in the concrete.
- Hammer the double-head nail L = 65 mm (**13**) into a crooked position or remove the projection if it projects from the back side of the formlining.

## Components

- 1** Stopend Sleeve DW 15
- 13** Double-head nail L = 65 mm

## Application

1. Fix the nail plug (**1.1**) to the formwork with a double-head nail L = 65 mm (**13**). (Fig. A1.02)
2. Place the Stopend Sleeve DW 15 (**1**) on the nail plug (**1.1**). (Fig. A1.03)
3. Concrete the wall. (Fig. A1.04)
4. Strike the formwork with nail plugs (**1.1**). (Fig. A1.05)

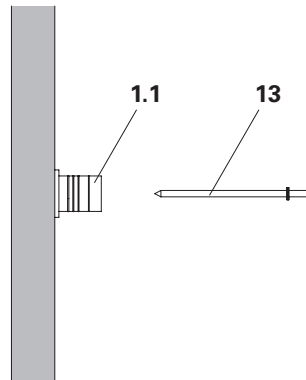

Fig. A1.02

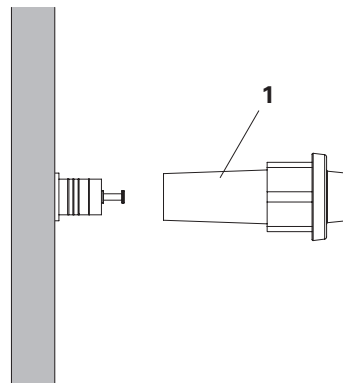

Fig. A1.03

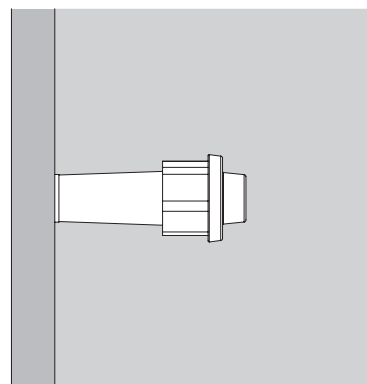

Fig. A1.04

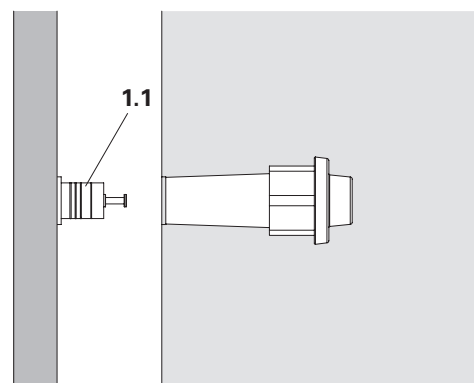

Fig. A1.05

## Overview



- Formwork bracket for forming small cantilevers up to 45 cm and vertical stopends up to 30 cm.



### Danger

If the distance between the Stopend Sleeves DW 15 is too large, the system may become overloaded and fall down!  
This could result in serious injuries or even death.  
⇒ Observe permissible distances, see tab. A2.01.



### Danger

If Formwork Bracket-2 is used as a work platform, the system can become overloaded and fall down!  
This could result in serious injuries or even death.  
⇒ Do not use Formwork Bracket-2 as a work platform.

### Permissible distances [m] depending on the slab thickness and cantilever

Slab thickness d [m]	Cantilever f [m]				
	0.10	0.20	0.30	0.40	0.45
0.20	2.50	2.50	2.50	1.85	1.60
0.30	1.00	1.00	1.00	1.00	1.00

Tab. A2.01

The above values relate to the load-bearing capacity of Formwork Bracket-2 (2).

Smaller distances may be required depending on the formlining used. The maximum tie tensile force is 6.5 kN and the shear force is 5.3 kN. These are characteristic values.

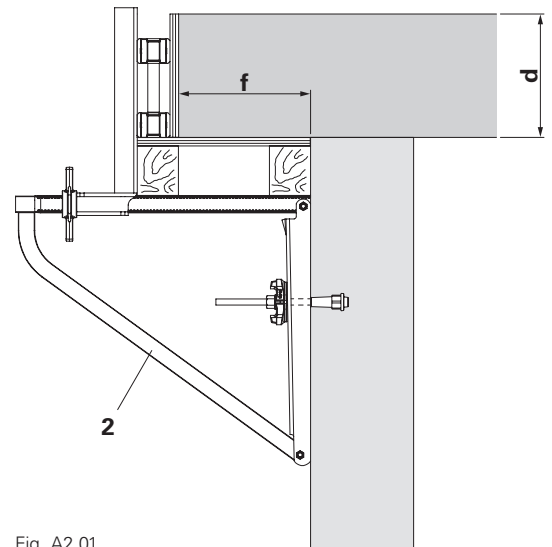

Fig. A2.01

### Components

- 
- 1 Stopend Sleeve DW 15
  - 2 Formwork Bracket-2
  - 7 Tie Rod B 15, L = 30 m
  - 8 Wingnut Counterplate DW 15
  - 10 Guardrail Post HSGP-2
  - 11 Square timber
  - 14 Screw 5 x 20
-

## Assembly



- Do not step on the formwork of the console bracket.
- Do not pour concrete directly onto the formwork.
- Note the maximum cantilever, it is not possible to add console brackets at a later time.



- The Stopend Sleeve DW 15 (**1**) must be concreted into the wall during the concreting process.
- For the spacing of Formwork Brackets-2 (**2**), see Tab. A2.01.
- The maximum cantilever of the squared timber (**11**) must be adapted to the load-bearing capacity of the selected timber.
- Carry out the assembly and disassembly work from a safe workplace, e.g. platform or scaffold.

## Assembly

- Screw the Tie Rod B 15, L = 0.30 m (**7**) into the Stopend Sleeve DW 15 (**1**). (Fig. A2.02)
- Position Formwork Bracket-2 (**2**) in the specified place.
- Fasten Formwork Bracket-2 (**2**) with Wingnut Counterplate DW 15 (**8**) and firmly tighten Wingnut Counterplate DW 15 (**8**). (Fig. A2.03)
- Adjust cantilever with Drive Nut PSG 52 (**2.1**).
- Mount the formwork and fix it in place with screws 5 x 20 (**14**). (Fig. A2.04)
- Install the slab edge stop end.
- Insert Guardrail Post HSGP-2 (**10**) into prop (**2.2**) and fit the guardrail. (Fig. A2.05)
- Concrete the slab with cantilever and fit the toe board. (Fig. A2.06)

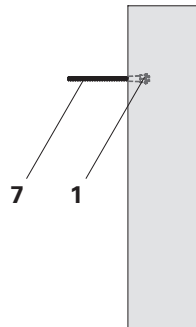

Fig. A2.02

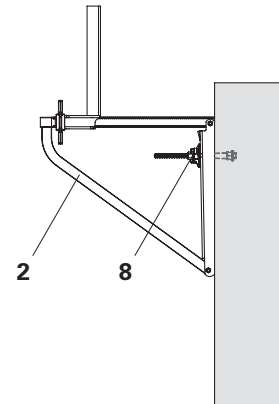

Fig. A2.03

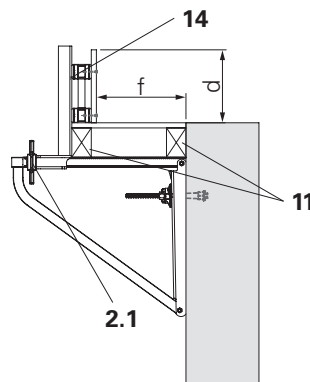

Fig. A2.04

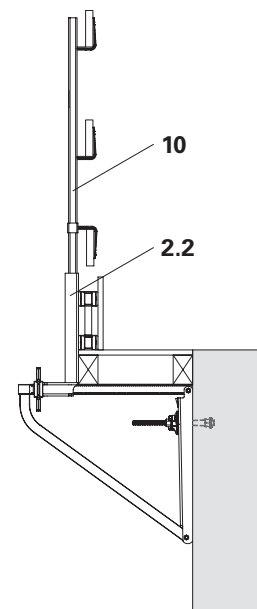

Fig. A2.05

## Striking

- Dismantle the guardrail and Guardrail Post HSGP-2 (**10**).
- Unscrew the Drive Nut PSG 52 (**2.1**) and remove the stop end formwork.
- Remove Wingnut Counterplate DW 15 (**8**), remove Formwork Bracket-2 (**2**) and remove Tie Rod B 15, L = 0.30 m (**7**). (not shown)

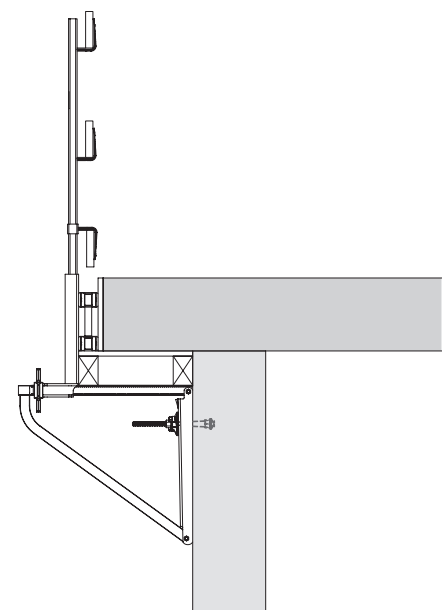

Fig. A2.06

## Overview



- Slab stopend bar for forming vertical slab formwork up to 50 cm slab thickness.



### Danger

If the distance between the Stopend Sleeves DW 15 is too large, the system may become overloaded and fall down!  
This could result in serious injuries or even death.  
⇒ Observe permissible distances, see tab. A3.01.



- Use in conjunction with HSGP-2 and boards 15 x 3.
- The connection to the structure is made with a Stopend Sleeve DW 15\*.
- The max. tie tensile force is 6.3 kN. This is a characteristic value.

\* For applications with edge distances  $a < 15$  cm, separate verification of the anchoring is necessary.

### Permissible distances [m] depending on the slab thickness and cantilever

Slab thickness d [m]	0.20	0.30	0.40	0.50	Hole
with lateral protection (guardrail boards or Side Mesh Barrier PMB)	1.20	1.12	0.80	0.66	①
	1.20	1.12	0.93	0.76	②
	1.30	1.24	1.14	0.99	③
	1.43	1.37	1.34	–	④
	1.58	1.53	–	–	⑤
	1.77	–	–	–	⑥
without lateral protection	1.75	1.15	0.80	0.66	①
	2.22	1.56	1.12	0.89	②
	2.90	2.07	1.45	1.21	③
	3.00	1.67	2.00	–	④
	3.00	3.00	–	–	⑤
	3.00	–	–	–	⑥

Tab. A3.01

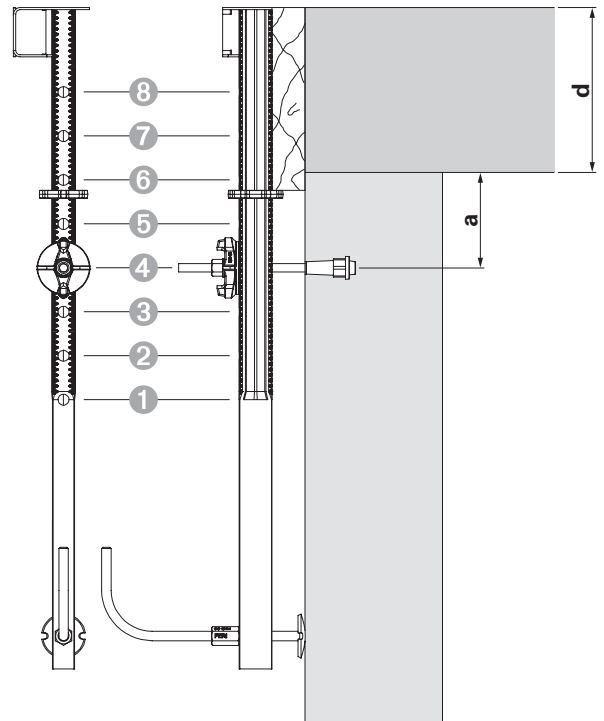

Fig. A3.01

### Components

- 1 Stopend Sleeve DW 15
- 3 Slab Stopend Bar 105
- 7 Tie Rod B 15, L = 30 m
- 8 Wingnut Counterplate DW 15
- 10 Guardrail Post HSGP-2



## Assembly



- Do not pour concrete directly onto the formwork (distance  $\geq 1.00$  m).
- Tighten the Wingnut Counterplate DW 15 (8) before fitting the Guardrail Posts HSGP-2 (10).



- The Stopend Sleeve DW 15 (1) must be concreted into the wall during the concreting process.
- Carry out the assembly and disassembly work from a safe workplace, e.g. platform or scaffold.

## Assembly

- Screw the Tie Rod B 15, L = 0.30 m (7) into the Stopend Sleeve DW 15 (1). (Fig. A3.02)
- Place the Slab Stopend Bar 105 (3) with the specified hole on Tie Rod B 15, L = 0.30 m (7) and secure with Wingnut Counterplate DW 15 (8). (Fig. A3.03)
- Adjust the height of the slab edge stop end with the levelling nut (3.2).
- Place the slab edge stop end on the levelling nut (3.2). (Fig. A3.04)
- Adjust the Slab Stopend Bar 105 (3) with the waler jack (3.3).
- Firmly tighten Wingnut Counterplate DW 15 (8).
- Insert Guardrail Posts HSGP-2 (10) into the holes (3.1) and fit the guardrail. (Fig. A3.05)
- Concrete the slab and fit the toe board. (Fig. A3.06)

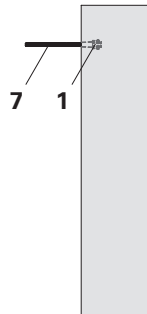

Fig. A3.02

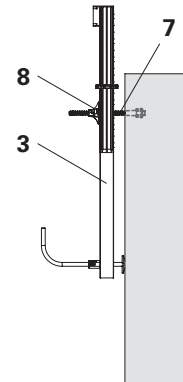

Fig. A3.03

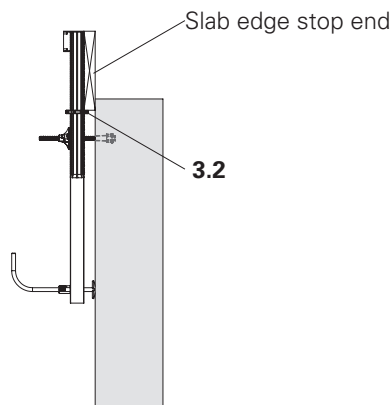

Fig. A3.04

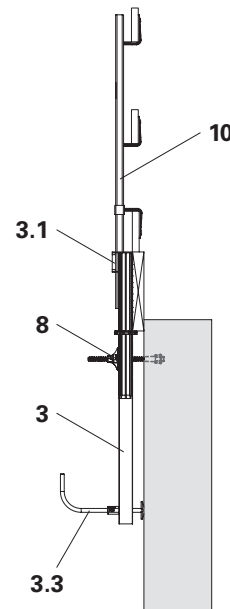

Fig. A3.05

## Striking

- Dismantle the guardrail and Guardrail Post HSGP-2 (10).
- Remove Wingnut Counterplate DW 15 (8), remove Slab Stopend Bar 105 (3) and remove Tie Rod B 15, L = 0.30 m (7). (not shown)

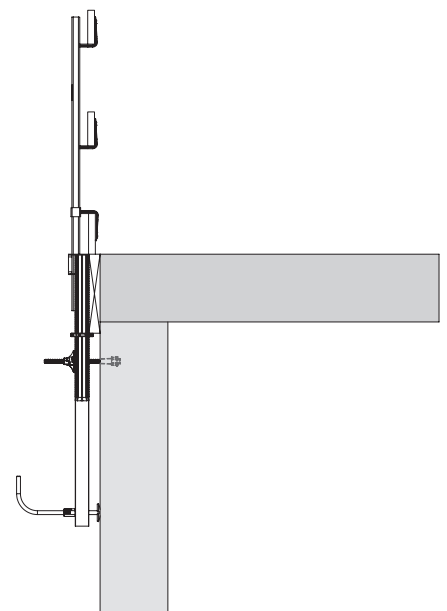

Fig. A3.06

## Overview



Wall clamp for forming strip foundations and small beams.



### Warning

The wall clamp can fall down when used with beam formwork! This could result in serious injuries or even death.  
 ⇒ Secure the wall clamps with screws to prevent them from falling down.

Wall clamp	Max. clamping width	Concreting height	Recommended distance
Wall Clamp 55	55 cm	≤ 30 cm	120 cm
Wall Clamp 75	75 cm	≤ 40 cm	100 cm
Wall Clamp 105	105 cm	≤ 50 cm	80 cm

Tab. A4.01

### Wall Clamp 55

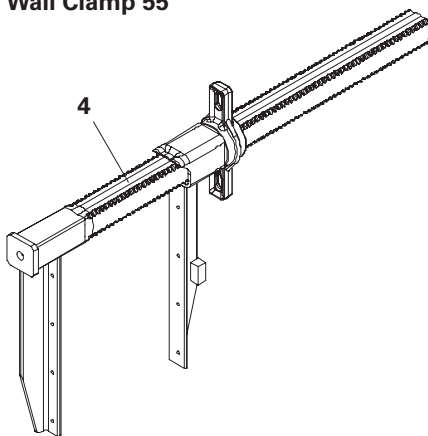

Fig. A4.01

### Wall Clamp 75

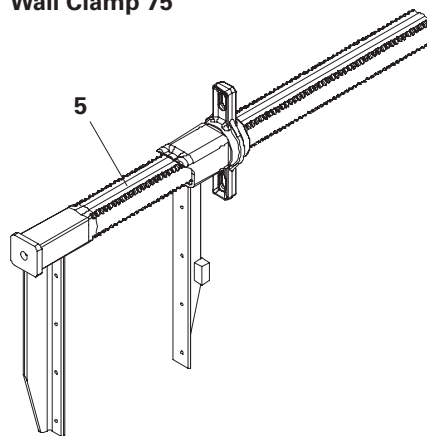

Fig. A4.02

### Wall Clamp 105

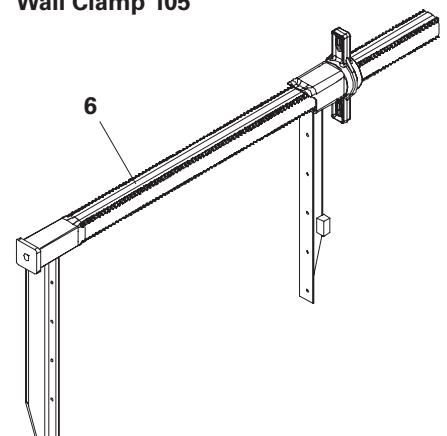

Fig. A4.03

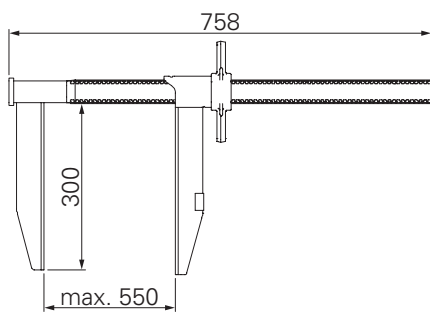

Fig. A4.01a

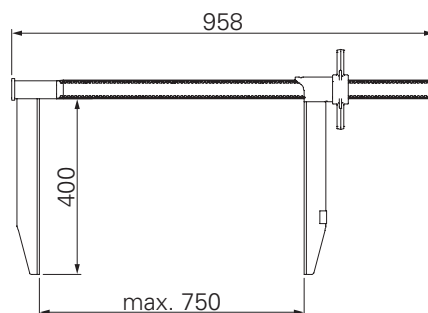

Fig. A4.02a

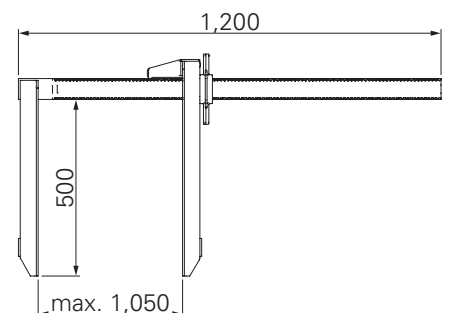

Fig. A4.03a

## Assembling beam formwork



- Carry out assembly and disassembly with two members of specialist personnel.
- The upper and lower ends of the wall clamp must be in full contact.

### Assembly

1. Mount the beam formwork.
2. Fix the fixed stringer (4.1) of the wall clamp (4 / 5 / 6) with screw 5 x 30 (14).
3. Pretension the loose stringer (4.2) with Drive Nut PSG 52 (4.3).
4. Fix the loose stringer (4.2) of the wall clamp (4 / 5 / 6) with screw 5 x 20 (14).

(Fig. A4.04 + A4.04a)

### Disassembly

1. Undo screw 5 x 30 (14) and secure the wall clamp (4 / 5 / 6) to prevent it from falling down.
2. Remove the wall clamp (4 / 5 / 6). (not shown)

## Assembling foundation formwork



The upper and lower ends of the wall clamp must be in full contact.

### Assembly

1. Mount the foundation formwork.
  2. Place the fixed stringer (4.1) over the entire surface of the foundation formwork.
  3. Pretension the loose stringer (4.2) with Drive nut PSG 52 (4.3).
- (Fig. A4.05)



Oil the wall clamps with formwork oil, this makes it easier to remove concrete residue.

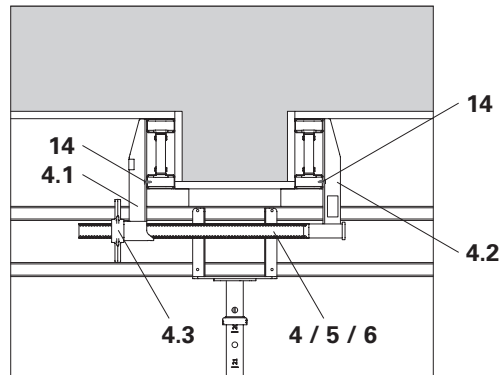

Fig. A4.04a

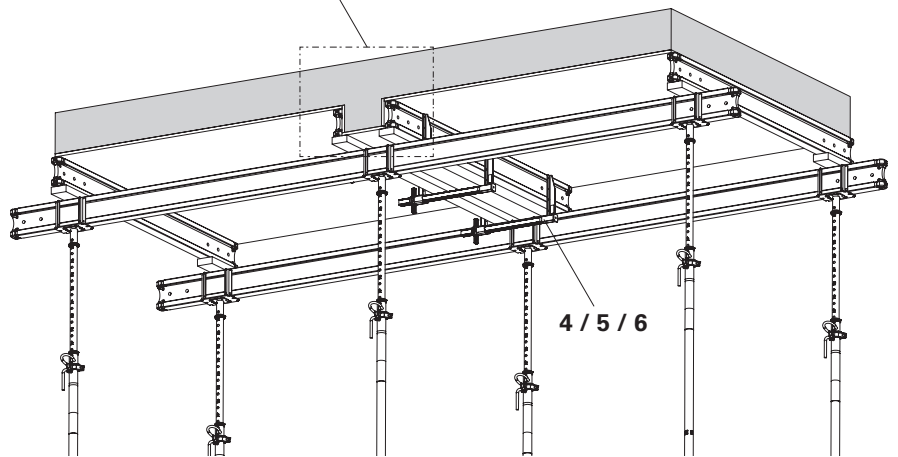

Fig. A4.04

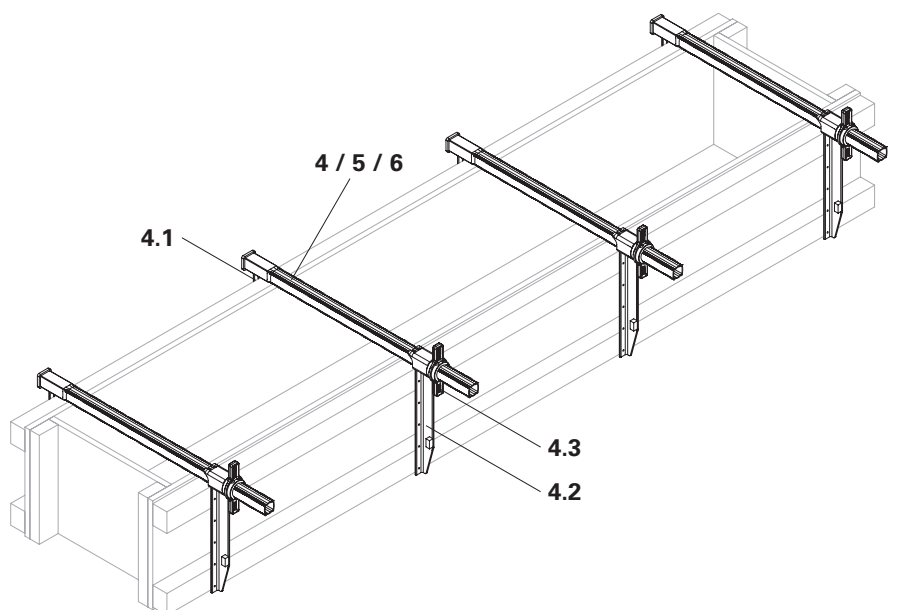

Fig. A4.05

Item no.	Weight kg
065039	0.075

### Stopend Sleeve DW 15

Anchoring for PERI stopend systems. With nailed plugs.

### Technical Data

Permissible load: see PERI Design Tables.

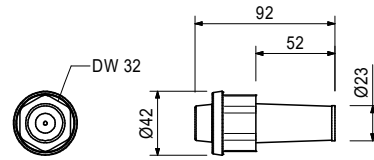
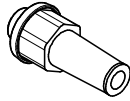

Accessories

065060	0.001
--------	-------

### Plug for Stopend Sleeve DW 15

065062	9.810
--------	-------

### Formwork Bracket-2

For forming of small cantilevers up to 45 cm and vertical stopends up to 30 cm.

### Technical Data

Permissible load: see PERI Design Tables.

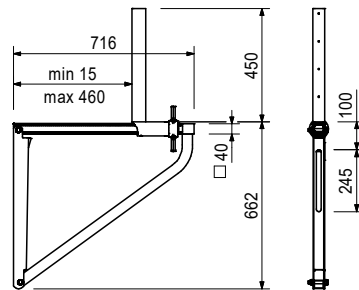
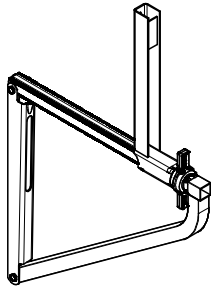

Accessories

116292	4.720
--------	-------

### Guardrail Post HSGP-2

065063	6.630
--------	-------

### Slab Stopend Bar 105

For forming with vertical slab stopend formwork for up to 50 cm slab thicknesses.

### Technical Data

Permissible load: see PERI Design Tables.

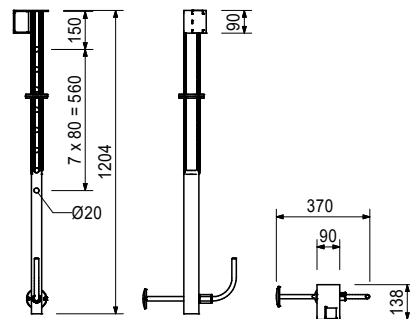
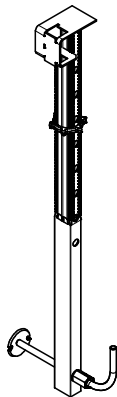

Accessories

116292	4.720
--------	-------

### Guardrail Post HSGP-2

Item no.	Weight kg
065045	5.020

### Wall Clamp 55

For forming strip foundations, small beams etc..

### Technical Data

For utilizing the max. concreting height of 30 cm, we recommend a distance of 1.20 m on foundations.

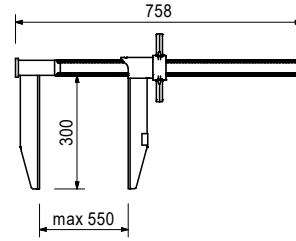
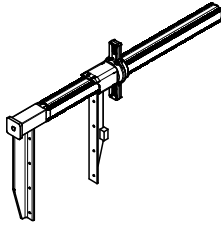

065076	6.160
--------	-------

### Wall Clamp 75

For forming strip foundations, small beams etc..

### Technical Data

For utilizing the max. concreting height of 40 cm, we recommend a distance of 1.00 m on foundations.

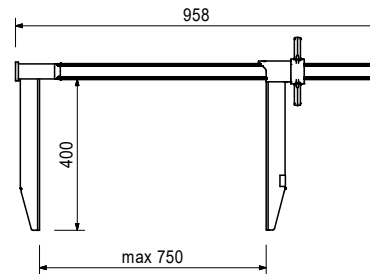
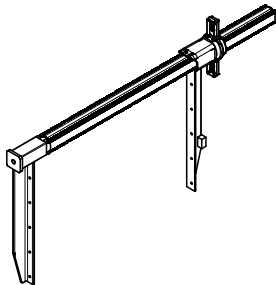

065046	13.400
--------	--------

### Wall Clamp 105

For forming strip foundations, small beams etc..

### Technical Data

For utilizing the max. concreting height of 50 cm, we recommend a distance of 0.80 m on foundations.

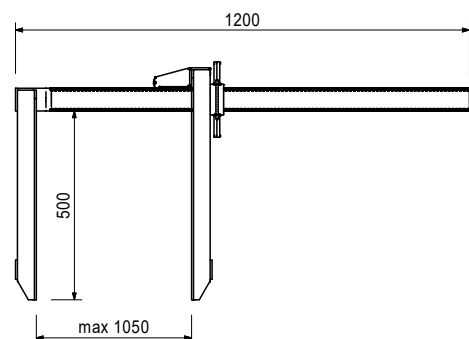
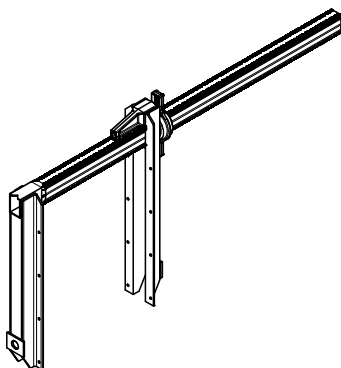

Item no.	Weight kg
030150	0.420

**Tie Rod B 15, l = 0.30 m**

**Note**

Weldable! Observe approval!

**Technical Data**

Permissible load 90 kN.

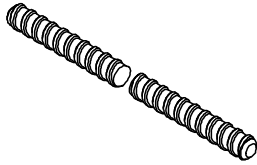

030110	0.799
--------	-------

**Wingnut Counterplate DW 15, galv.**

For anchoring with Tie Rod DW 15 and B 15.

**Technical Data**

Permissible load 90 kN.

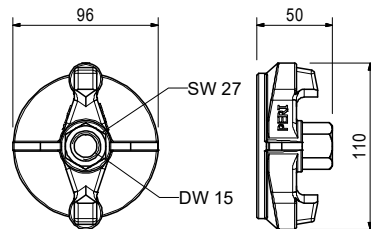

024540	0.005
--------	-------

**TSS-Torx 6 x 40, galv.**

For Torx Bits TX 30. Self-drilling.

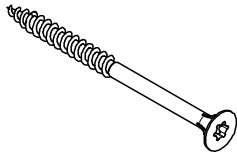
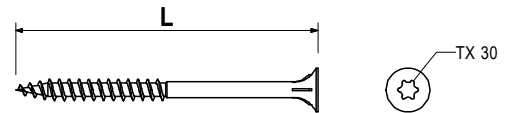

116292	4.720
--------	-------

**Guardrail Post HSGP-2**

As guardrail for different systems.

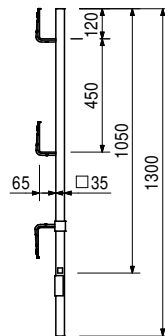

Item no.	Weight kg
018280	1.000

**Double Head Nail, l = 65 mm**

**Note**

Delivery unit: carton with 1000 pieces.

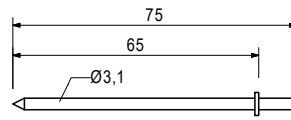
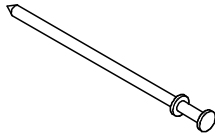

**The optimal system  
for all projects and every  
requirement**



**Wall formwork**



**Column formwork**

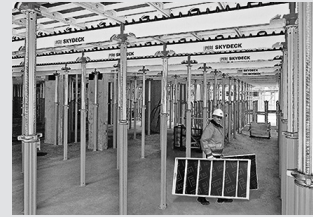

**Slab formwork**



**Climbing systems**



**Bridge formwork**



**Tunnel formwork**



**Shoring**



**Working scaffolds**



**Working scaffolds facade**



**Working scaffolds industry**



**Means of access**



**Safety scaffolds**



**Safety systems**



**System-independent accessories**



**Services**



**PERI AG**  
**Formwork Scaffolding Engineering**  
 Rudolf-Diesel-Strasse 19  
 89264 Weissenhorn  
 Germany  
 Telephone +49 (0)7309.950-0  
 Fax +49 (0)7309.951-0  
 info@peri.de  
 www.peri.com

