

VST Heavy-Duty Shoring Tower

Instructions for Assembly and Use – Standard Configuration

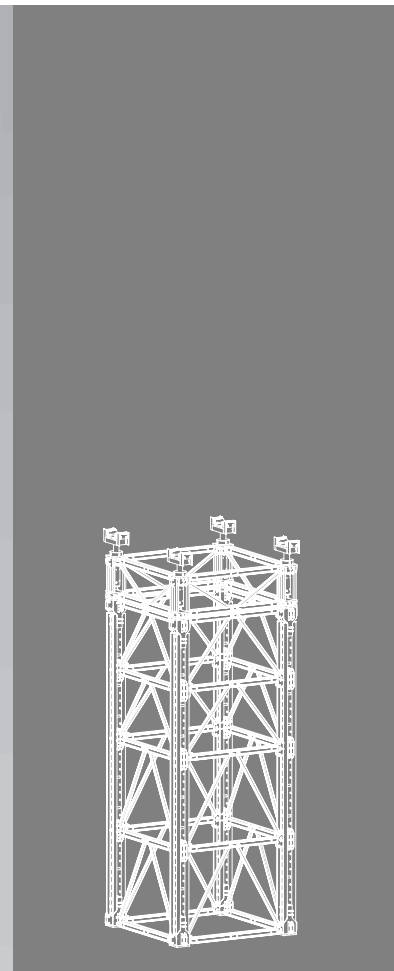
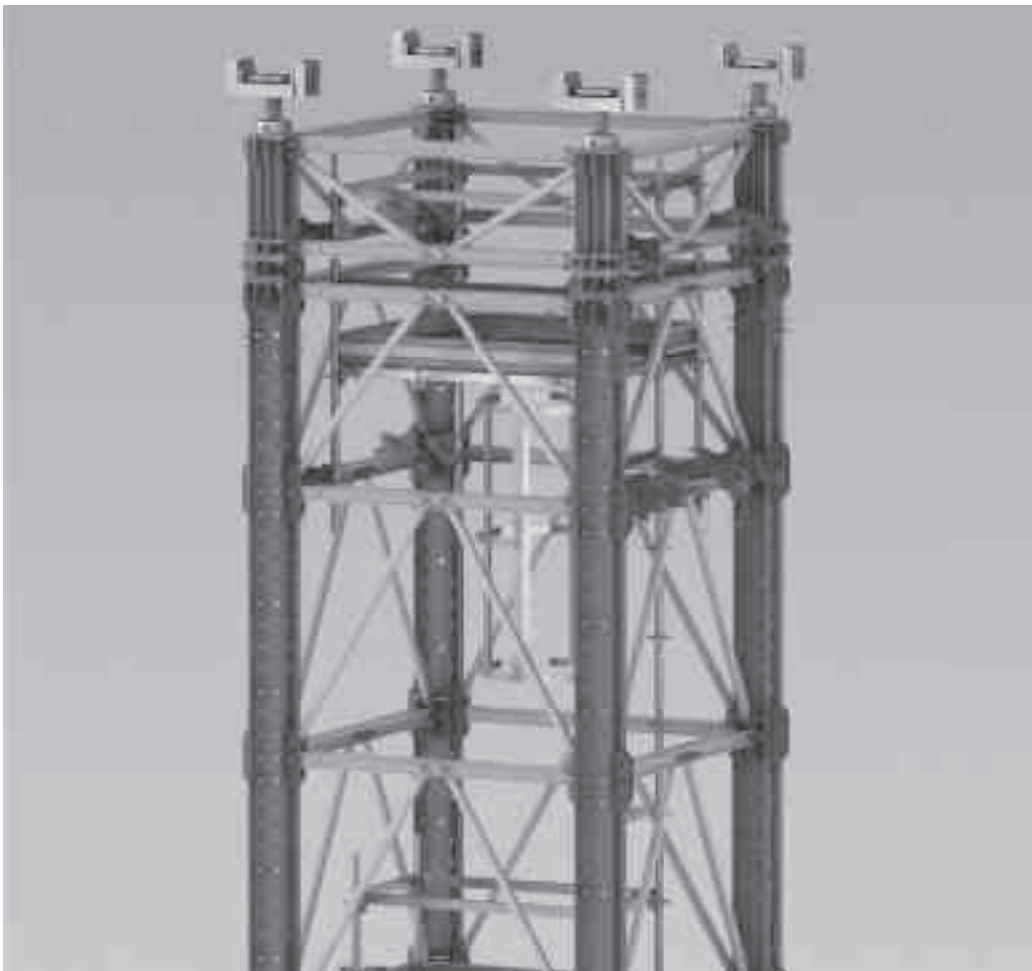

Overview

Main components	1
Key	2
Presentational reference	2

Introduction

Target groups	3
Additional technical documentation intended use	3
Instructions for Use	4
Cleaning and maintenance instructions	4

Safety instructions

Cross-system	6
System-specific	7
Storage and transportation	7

VST Heavy-Duty Shoring Tower

A1	Module overview	
	Overview of Module VST	8
	Arrangement of the Bracing	
	Connectors VST	9
	Module VST components	10
	Additional components	11
A2	Module VST 125	12
A3	Module VST 175	13
A4	Module VST 275	14
A5	Module VST 375	15
A6	Module VST 525	16
A7	Module VST 775	17
A8	Module VST 1025	18
A9	Head Spindle Frame VST	19
A10	Head Spindle VST 100	20
A11	VST Tower Configuration 1	21
A12	VST Tower Configuration 2	22
A13	VST Tower Configuration 3	23
A14	VST Tower Configuration 4	24
A15	Arrangement of the Height Adjusts	25
A16	Assembly of two Cross Connectors VST on the RCS / Bracing Connector VST	26
A17	Connecting Adapter VST-SRU	27
A18	VST Module with working platform	28
A19	VST Module with additional legs	30
A20	Hydraulic Unit VST	31

Assembly

B1	Operating states and loads	
	Operating state: mounting	32
	Operating state: lowering and dismantling	32
B2	Assembly of the VST Leg	
	Preparation of the RCS Rail	33
	Preparation of the Prop Base VST 48	33
	Preparation of the Prop Connector VST 48	33
	Prop Connector VST 48	34
	Prop Base VST 48	35
	Bracing Connector VST	36
	Cross Connector VST	37
B3	Module Assembly	
	Horizontal Ledger VST 200	38
	Diagonal Strut VST	39
B4	Head Spindle Frame	
	Mounting the Head Spindle Frame	40
	Adjusting the spacer plates of the Head Spindle VST 100	42
B5	Pre-assembly of the tower segments	
	Tower assembly with VST components	43
	Tower assembly with SLS Spindles	46
B6	Working platform	49

Assembly

C1	Erecting the tower with VST components	51
C2	Erection of a single module	53
C3	Anchoring	57

Application

D1	Height adjustment (± 140 mm)	
	Manual adjustment	58
	Adjustment with the hydraulic cylinder	59
D2	Lowering procedure	60

Dismantling

E1	Dismantling	
	Preparation of the towers	61
	Module preparation	62
	Dismantling the tower	63
	Dismantling the module	63

Work preparation

F1	Pre-dimensioning of the permissible leg load at the head	64
F2	Load-bearing capacities	65
F3	Moving the module	
	Without Head Spindle Frame	66
	With Head Spindle Frame	67
F4	Moving the towers	
	Without Head Spindle Frame	68
	With Head Spindle Frame	69
F5	Combination Table 225 – 987.5 cm	70
F6	Combination Table 1000 – 1987.5 cm	72
F7	Combination Table 2000 – 2987.5 cm	74
F8	Combination Table 3000 – 4000 cm	76

Main components

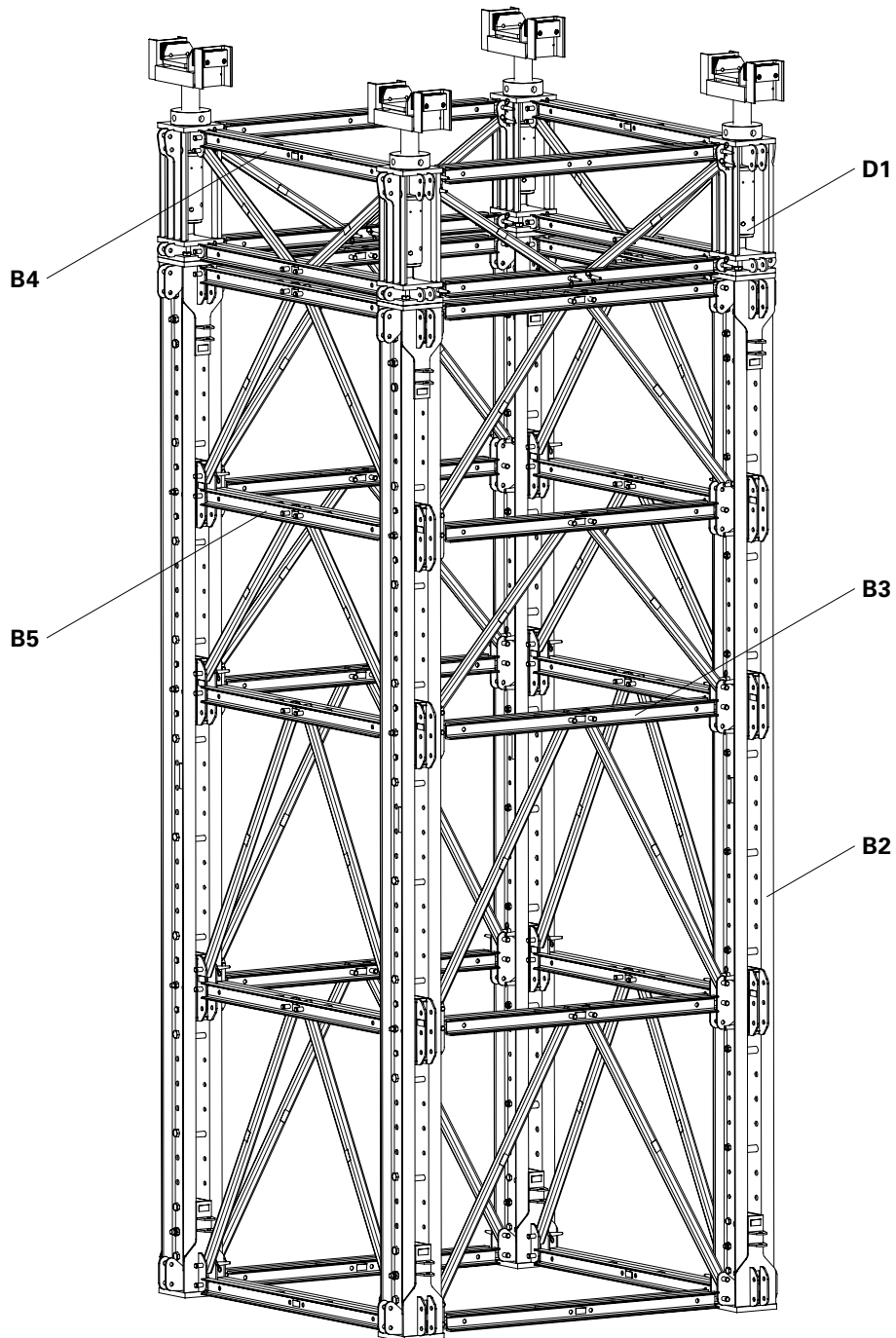

B2 Assembly of the VST Leg

B3 Module Assembly







B4 Head Spindle Frame

B5 Tower Assembly

D1 Height Adjustment Head Spindle VST (+/- 140 mm)

Key

Pictogram | Definition

-  Safety instructions
-  Note
-  Load-bearing point
-  Visual check
-  Tip
-  Misapplication
-  Correct application

Dimension specifications

Dimensions are usually given in cm. Other units of measure, e.g. m, are shown in the illustrations.

Conventions

- Instructions are numbered with:
1., 2., 3.
- The result of an instruction is shown by: →
- Position numbers are clearly provided for the individual components and are given in the drawing, e.g. **1**, in the text in brackets, for example (1).
- Multiple position numbers, i.e. alternative components, are represented with a slash, e.g. **1 / 2**.

Arrows

- ➔ Arrow representing an action.

Presentational reference

The illustration on the front cover of these instructions is understood to be a system representation only. The assembly steps presented in these Instructions for Assembly and Use are shown in the form of examples with only one component size. They are valid accordingly for all component sizes contained in the standard configuration.

For a better understanding, detailed illustrations are partly incomplete. The safety installations which have possibly not been featured in these detailed drawings must nevertheless still be available.

Target groups

Contractors

These Instructions for Assembly and Use are designed for contractors who use the scaffolding either for

- assembling, modifying and dismantling operations, or
- use it e.g. for concreting or, x
- who have it used, e.g. for forming operations.

Construction site coordinator

The Safety and Health Coordinator*

- is appointed by the client,
- must identify potential hazards during the planning phase,
- determines measures that provide protection against risks,
- creates a safety and health plan,
- coordinates the protective measures for the contractor and site personnel so that they do not endanger each other,
- monitors compliance with the protective measures.

Competent personnel

Due to the specialist knowledge gained from professional training, work experience and recent professional activity, the competent person has a reliable understanding of safety-related issues and can correctly carry out inspections. Depending on the complexity of the test to be undertaken, e.g. scope of testing, type of testing or the use of a certain measuring device, a range of specialist knowledge is necessary.

Qualified specialists

The scaffolding may only be assembled, modified or dismantled by personnel who are suitably qualified to do so. For the work to be carried out, the qualified specialists must have received instructions** which contain at least the following points:

- Explanation of the plan for the assembly, modification or dismantling of the scaffolding in an understandable form and language.
- Description of measures in order to safely assemble, modify or dismantle the scaffolding.
- Designation of the preventive measures to avoid the risk of persons and objects falling.

- Designation of the safety precautions in the event of changing weather conditions which could adversely affect the safety of the scaffolding as well as the personnel concerned.
- Details regarding the permissible loads.
- Description of any other risks that are associated with the assembly, modification or dismantling procedures.



- **In other countries, ensure that the relevant national guidelines and regulations in the respective current version are complied with!**
- **If no country-specific regulations are available, it is recommended to proceed according to German rules and regulations.**

* Valid in Germany: Regulations for Occupational Health and Safety on Construction Sites 30 (RAB 30).

** Instructions are given by the contractor himself or a qualified person selected by him.

Additional technical documentation

- Instructions for Assembly and Use
 - PERI UP Rosett 72
- Instructions for Use
 - Pallets and Stacking Devices
 - Hydraulic Head Spindle Device VST
- Brochure
 - VARIOKIT Engineering Construction Kit

Intended use

Product description

PERI products have been designed for exclusive use in the industrial and commercial sectors by qualified personnel only.

The VST Heavy-Duty Shoring Tower can transfer high loads from the formwork, for in-situ concrete bridges and all temporary support constructions for structural components.

The system can be used for all types of supporting structures, with a permissible leg load of up to 700 kN (height-dependent).

Through the use of the Hydraulic Head Spindle Device VST, the system allows adjustment of the head spindle under full load.

The VST Heavy-Duty Shoring Tower is a standard system which offers the possibility to support bridge formwork on girders or truss girders, prefabricated elements and other temporary load situations.

Features

Main components are standardized PERI components taken from the VARIOKIT Engineering Construction Kit.

The base of the structure is formed by two parallel legs consisting of RCS Climbing Rails which are connected to each other by means of Horizontal Ledgers VST 200 and Diagonal Struts VST at a centre distance of 2 m.

The Climbing Rail RCS is additionally braced between the U-profiles with Bracing Connectors VST at a distance of max. 1.5 m upwards in order to increase the bending stiffness in the weak axis.

The connection in the longitudinal direction of the module is carried out with the Prop Base VST 48 and Prop Connector VST 48.

The module can be configured with Horizontal Ledgers VST 200 and Diagonal Struts VST to form a tower.

The flexible adaptation for achieving the required height can be carried out using Modules VST 125 to VST 1025 in increments of 25 cm (see Section F Work Preparation).

Fine adjustment of ± 140 mm is possible with the Head Spindle VST.

System dimensions

Axis dimension of the standard configuration.

- 2 m x 2 m
- Height: continuously adjustable for other configurations, see Section A12 to A15.

Permissible load-bearing capacity

- Up to 700 kN (height-dependent) per leg.

Instructions for Use

The use in a way not intended, deviating from the standard configuration or the intended use according to the Instructions for Assembly and Use, represents a misapplication with a potential safety risk, e.g. risk of falling.

Only PERI original components may be used. The use of other products and spare parts is not allowed.

Changes to PERI components are not permitted.

Cleaning and maintenance instructions

In order to maintain the value and operational readiness of the PERI products over the long term, clean the elements after each use.

Some repair work may also be inevitable due to the tough working conditions. The following points should help to keep cleaning and maintenance costs as low as possible.

Do not clean powder-coated or galvanized components with steel brushes or metal scrapers.

Mechanical components, e.g. spindles, must be cleaned of dirt or concrete residue before and after use, and then greased with a suitable lubricant.

Provide suitable support for the components during cleaning so that no unintentional change in their position is possible.

Do not clean components suspended on a crane.

Any repairs to PERI products are to be carried out by qualified PERI personnel only.

Cross-system

General

The contractor must ensure that the Instructions for Assembly and Use supplied by PERI are available at all times and are understood by the site personnel.

These Instructions for Assembly and Use can be used as the basis for creating a risk assessment. The risk assessment is compiled by the contractor. These Instructions for Assembly and Use do not replace the risk assessment!

Always take into consideration and comply with the safety instructions and permissible loads.

For the application and inspection of PERI products, the current safety regulations and guidelines must be observed in the respective countries where they are being used.

Materials and working areas are to be inspected on a regular basis especially before each use and assembly for:

- signs of damage,
- stability and
- function.

Damaged components must be exchanged immediately on site and may no longer be used.

Safety components are to be removed only when they are no longer required.

Components provided by the contractor must conform with the characteristics required in these Instructions for Assembly and Use as well as all valid construction guidelines and standards. Unless otherwise indicated, this applies in particular to:

- Timber components: Strength Class C24 for Solid Wood according to EN 338.
- Scaffold tubes: galvanised steel tubes with minimum dimensions of $\varnothing 48.3 \times 3.2$ mm according to EN 12811-1:2003 4.2.1.2.
- Scaffold tube couplings according to EN 74.

Deviations from the standard configuration are only permitted after a further risk assessment has been carried out by the contractor.

On the basis of this risk assessment, appropriate measures for working and operational safety as well as stability are to be determined.

Corresponding proof of stability can be provided by PERI on request if the risk assessment and resulting measures to be implemented are available.

Before and after exceptional occurrences that may have an adverse effect regarding the safety of the formwork system, the contractor must immediately

- create an additional risk assessment, with appropriate measures for ensuring the stability of the scaffolding system being carried out based on the results,
- and arrange for an extraordinary inspection by a competent person. The aim of this inspection is to identify and rectify any damage in good time in order to guarantee the safe use of the scaffolding system.

Exceptional occurrences can include:

- accidents,
- longer periods of non-use,
- natural events, e.g. heavy rainfall, icing, heavy snowfall, storms or earthquakes.

Assembly, modification and dismantling work

Assembly, modification or dismantling of scaffolds may only be carried out by qualified specialists under the supervision of a competent person. The qualified specialists must have received appropriate training for the work to be carried out with regard to specific risks and dangers.

On the basis of the risk assessment and Instructions for Assembly and Use, the contractor must create installation instructions in order to ensure safe assembly, modification and dismantling of the scaffolding system.

Before initial use, the safe functioning of the scaffold must be checked by a competent person. The result of the inspection must be documented in an inspection record.

The contractor must ensure that the personal protective equipment required for the assembly, modification or dismantling of the system, e.g.

- safety helmet,
 - safety shoes,
 - safety gloves,
 - safety glasses,
- is available and used as intended.

If personal protective equipment against falling (PPE) is required or specified in local regulations, the contractor must determine appropriate attachment points on the basis of the risk assessment.

The personal protective equipment against falling to be used is determined by the contractor.

The contractor must

- provide safe working areas for site personnel which are to be reached through the provision of safe access ways. Areas of risk must be cordoned off and clearly marked.
- ensure the stability during all stages of construction, in particular during assembly, modification and dismantling of the formwork.
- ensure and prove that all loads are safely transferred.

Utilization

Every contractor who uses or allows the scaffolding system or sections of the scaffolding system to be used, has the responsibility for ensuring that the equipment is in good condition.

If the scaffolding system is used successively or at the same time by several contractors, the health and safety coordinator must point out any possible mutual hazards, and all work must be then coordinated.

System-specific

The components are to be inspected for signs of damage by authorised personnel at regular intervals.

Dirt which affects the functionality is to be removed immediately.

Damaged components are to be inspected, sorted out and replaced.

For information regarding the maintenance of the Hydraulic Head Spindle Device VST, see Instructions for Use.



Detailed project-specific static proof as well as planning is required for each time of use.

In addition, project-specific lifting and lowering plans are to be created.

Lifting or lowering operations are only to be performed when a competent person has given the go-ahead and the upper construction has sufficient load-bearing capacity.

All screw connections are to be secured with suitable nuts.

All fitting pin connections are to be secured with cotter pins.

Storage and transportation

Store and transport components ensuring that no unintentional change in their position is possible. Detach lifting accessories and slings from the lowered components only if they are in a stable position and no unintentional change is possible.

Do not throw off the components.

Use PERI load-bearing devices and lifting gear as well as only those load-bearing points provided on the component.

During the moving procedure,

- ensure that components are picked up and set down so that unintentional falling over, falling apart, sliding, falling down or rolling is avoided.
- no persons are allowed to remain under the suspended load.

Pre-assembled modules and towers are guided with ropes when moving them by crane.

The access areas on the jobsite must be free of obstacles and tripping hazards as well as being slip-resistant.

For transportation, the surface must have sufficient load-bearing capacity.

Use original PERI storage and transport systems, e.g. crate pallets, pallets or stacking devices.

Overview of Module VST

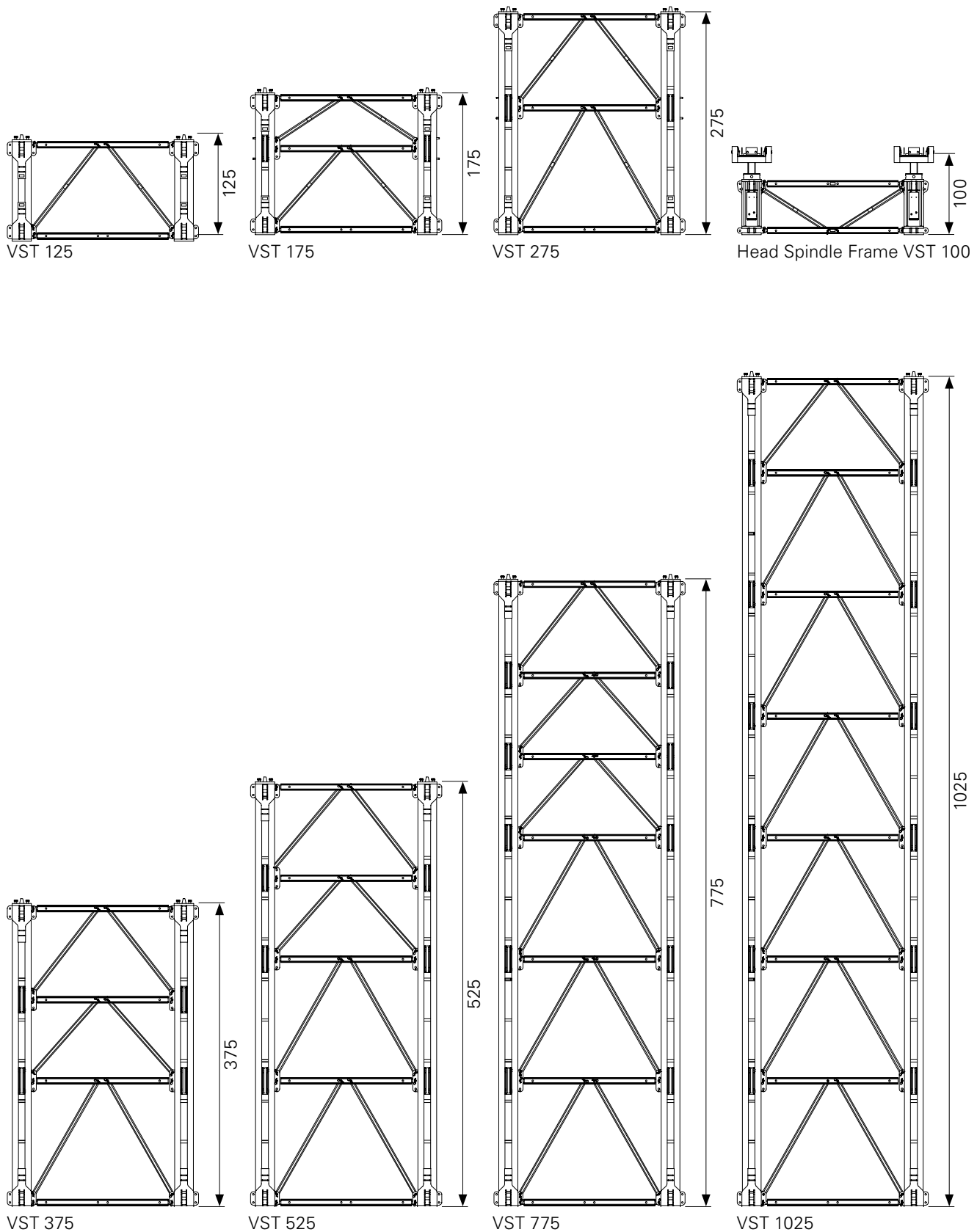

Fig. A1.01

Arrangement of the Bracing Connectors VST



Observe the assembly position of the Prop Base VST and Prop Connector VST.
(see Section B2)

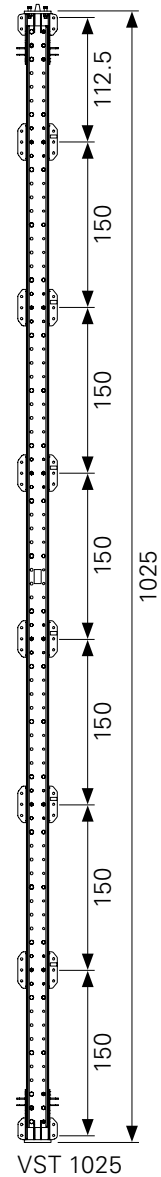
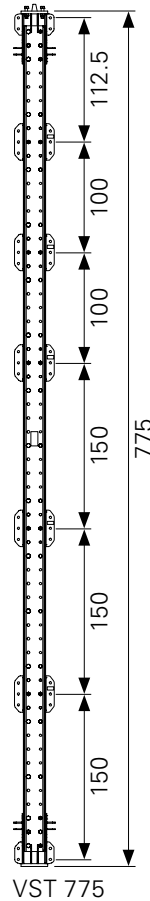
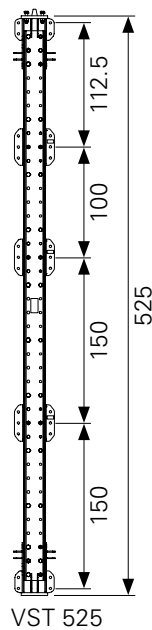
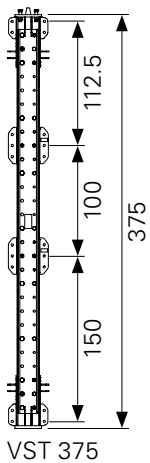
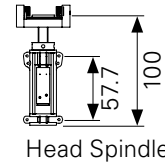
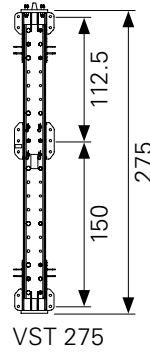
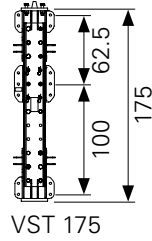
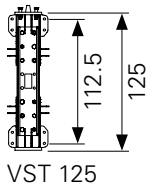

Fig. A1.02

Module VST components

	Name	Item no.
VST Legs consist of		
1	Climbing Rail Profile RCS 98	117585
2	Climbing Rail RCS 148	114166
3	Climbing Rail RCS 248	109469
4	Climbing Rail RCS 348	109470
5	Climbing Rail RCS 498	109471
6	Climbing Rail RCS 748	109472
7	Climbing Rail RCS 998	109610
The VST module consists of 2 VST Legs plus		
8	Bracing Connector VST	117411
9	Fitting Pin Ø 21 x 120	104031
10	Cotter Pin 4/1, galv.	018060
11	Fitting Pin Ø 26 x 120	111567
12	Cotter Pin 5/1, galv.	022230
13	Cross Connector VST	117425
14	Bolt ISO 4014 M20 x 120-8.8, galv.	113994
15	Nut ISO 7042 M20-8, galv.	781053
16	Sleeve VST, galv.	117492
17	Prop Base VST 48	117453
18	Bolt ISO 4014 M30 x 130-10.9	117452
19	Bolt ISO 4014 M24 x 140-10.9	114563
20	Nut ISO 7042 M24-8, galv.	105032
21	Prop Connector VST 48	117454
22	Bolt ISO 4014 M24 x 80-8.8, galv.	105416
23	Horizontal Ledger VST 200	117371
24	Diagonal Strut VST 200/150	117379
25	Diagonal Strut VST 200/100	117382
26	Diagonal Strut VST 200/112.5	117385
27	Diagonal Strut VST 200/62.5	117388

Table A1.01

Additional components

	Name	Item no.
28	Head Spindle VST 100	117465
28.1	Fork Head	
28.2	Spindle Nut	
28.3	Spindle Sleeve	
29	Mounting Shaft VST	117377
30	Heavy-Duty Spindle SLS	
31	Push-Pull Prop RS 1000, galv.	028990
32	Push-Pull Prop RS 1400, galv.	103800
33	Steel Waler Universal SRU U120	
34	Adapter VST-SRU	123823
35	Bolt ISO 4014 M16 x 100-10.9	Special
36	Sleeve Ø 21 x 2, L = 29 mm	Special
37	Cyl. Bolt ISO 4762 M20 x 150-8.8, galv.	118256
38	Connector UP-VST	117707
38.1	Retaining Lug	
39	Bolt Ø 20 x 140, galv.	105400
40	PERI Wedge K, galv.	024250
41	Leg Connector VST 200/37.5	117712
42	Horizontal Connector VST 37.5	117696
43	Hydraulic Unit VST 75	117678
43.1	Hydraulic Hose	
43.2	Hand Pump	
43.3	Manometer	
43.4	Hydraulic Cylinder	
44	Height Adjust VST 12.5	117391
45	Height Adjust VST 25	117433
46.1	Standard UVR 300	100012
46.2	Standard UVR 150	102860
47	Ledger UH 150	400021
48	Steel Waler SRZ U100	
49	Kicker AV	
50	Tie Rod DW 15	
51	Cam Nut DW 15, galv.	030130
52	Wingnut Pivot Plate DW 15, galv.	030370
53	Tie Rod DW 26	
54	Counterplate DW 26	123825
55	Hex. Nut DW 26 SW 46/80, weldable	030970

Table A1.02

Parts list for Module VST 125

Pos.	Name	Quantity
1	Climbing Rail Profile RCS 98	4
9	Fitting Pin \varnothing 21 x 120	8
10	Cotter Pin 4/1, galv.	8
15	Nut ISO 7042 M20-8, galv.	12
17	Prop Base VST	2
18	Bolt ISO 4014 M30 x 130-10.9	12
19	Bolt ISO 4014 M24 x 140-10.9	12
20	Nut ISO 7042 M24-8, galv.	12
21	Prop Connector VST 48	2
23	Horizontal Ledger VST 200	2
26	Diagonal Strut VST 200/112.5	2



Connecting means are pre-assembled in the VST components.

The total weight of a Module VST 125 is 370.20 kg.

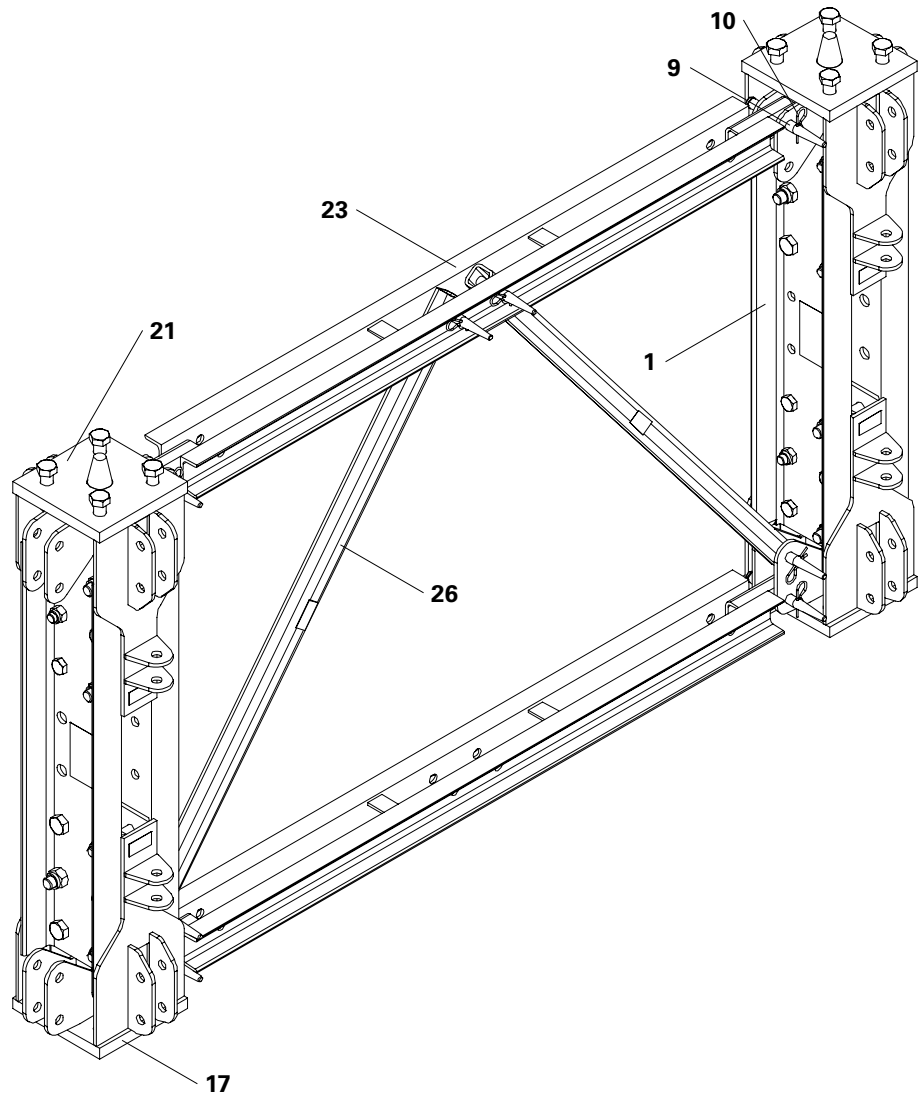

Fig. A2.01

Parts list for Module VST 175

Pos.	Name	Quantity
2	Climbing Rail RCS 148	2
8	Bracing Connector VST	2
9	Fitting Pin Ø 21 x 120	18
10	Cotter Pin 4/1, galv.	18
11	Fitting Pin Ø 26 x 120	4
12	Cotter Pin 5/1, galv.	4
13	Cross Connector VST	2
14	Bolt ISO 4014 M20 x 140-8.8	4
15	Nut ISO 7042 M20-8	16
16	Sleeve VST	2
17	Prop Base VST	2
18	Bolt ISO 4014 M20 x 130-10.9	12
19	Bolt ISO 4014 M24 x 140-10.9	12
20	Nut ISO 7042 M24-8	12
21	Prop Connector VST 48	2
23	Horizontal Ledger VST 200	3
25	Diagonal Strut VST 200/112.5	2
27	Diagonal Strut VST 200/62.5	2



Connecting means are pre-assembled in the VST components.

The total weight of a Module VST 175 is 528.44 kg.

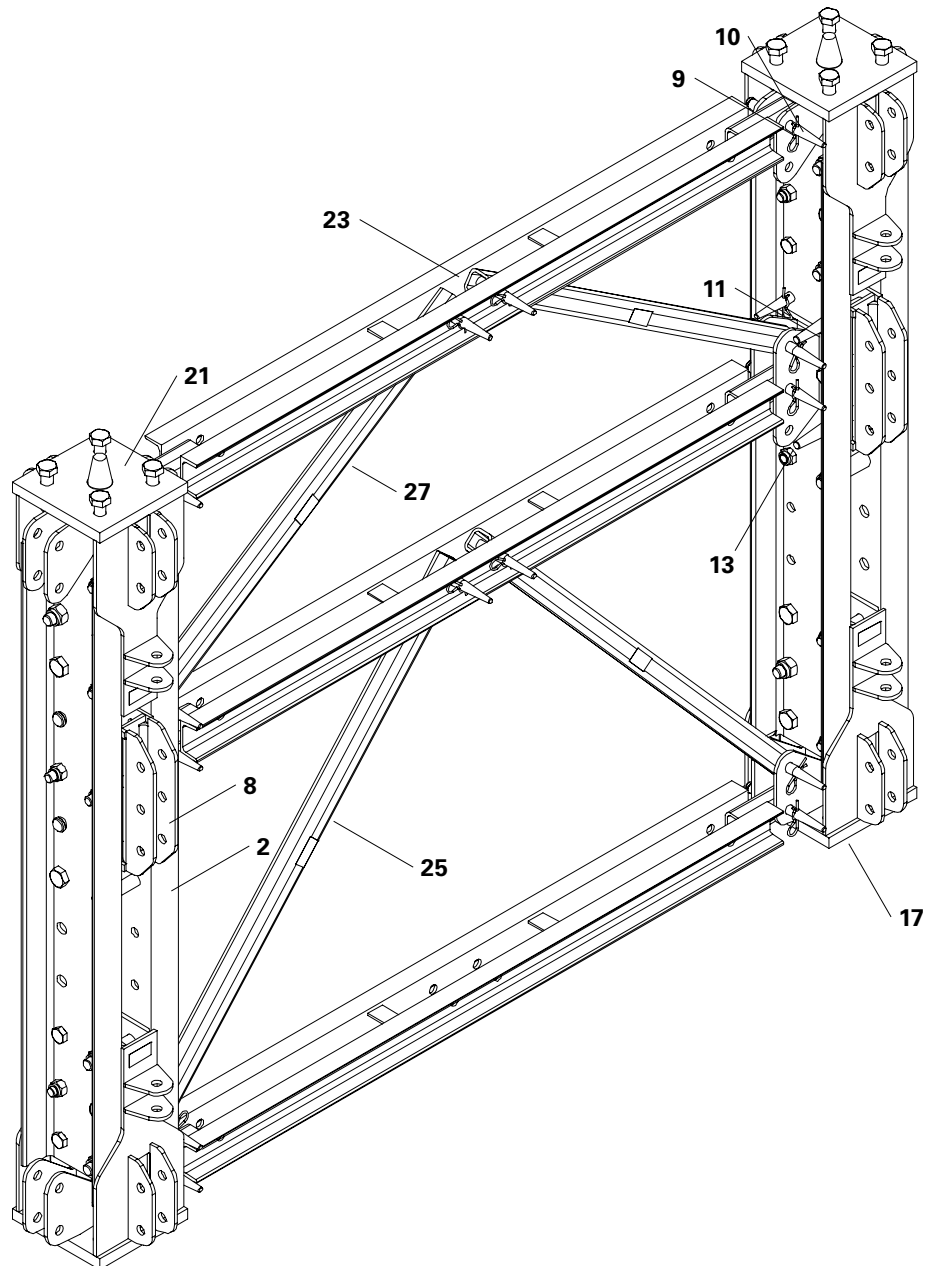

Fig. A3.01

Parts list for Module VST 275

Pos.	Name	Quantity
3	Climbing Rail RCS 248	2
8	Bracing Connector VST	2
9	Fitting Pin \varnothing 21 x 120	18
10	Cotter Pin 4/1, galv.	18
11	Fitting Pin \varnothing 26 x 120	4
12	Cotter Pin 5/1, galv.	4
13	Cross Connector VST	2
14	Bolt ISO 4014 M20 x 140-8.8	4
15	Nut ISO 7042 M20-8	16
16	Sleeve VST	2
17	Prop Base VST	2
18	Bolt ISO 4014 M20 x 130-10.9	12
19	Bolt ISO 4014 M24 x 140-10.9	12
20	Nut ISO 7042 M24-8	12
21	Prop Connector VST 48	2
23	Horizontal Ledger VST 200	3
24	Diagonal Strut VST 200/150	2
26	Diagonal Strut VST 200/112.5	2



Connecting means are pre-assembled in the VST components.

The total weight of a Module VST 275 is 644.02 kg.

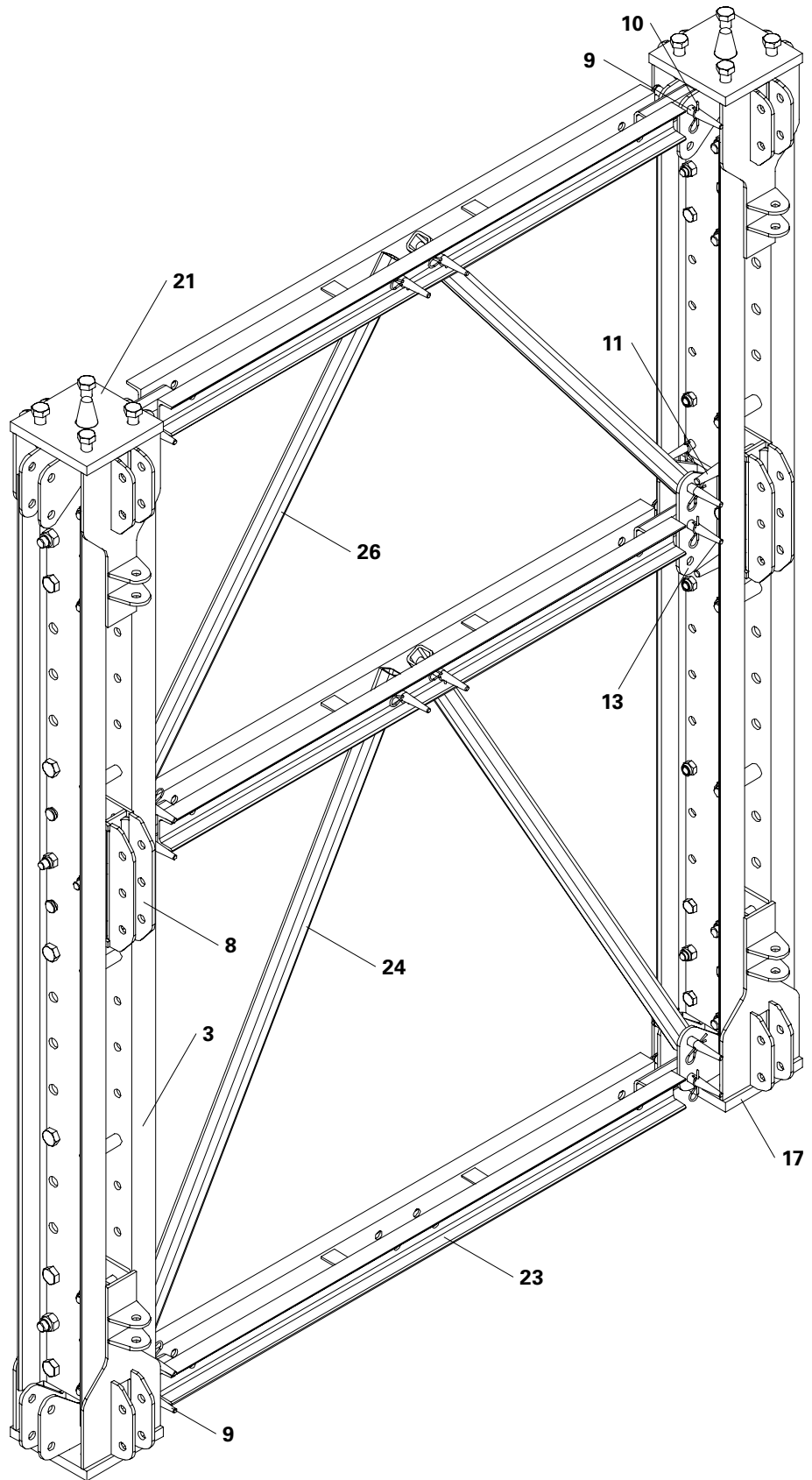

Fig. A4.01

Parts list for Module VST 375

Pos.	Name	Quantity
4	Climbing Rail RCS 348	2
8	Bracing Connector VST	4
9	Fitting Pin \varnothing 21 x 120	28
10	Cotter Pin 4/1, galv.	28
11	Fitting Pin \varnothing 26 x 120	8
12	Cotter Pin 5/1, galv.	8
13	Cross Connector VST	4
14	Bolt ISO 4014 M20 x 120-8.8	8
15	Nut ISO 7042 M20-8	20
16	Sleeve VST	4
17	Prop Base VST	2
18	Bolt ISO 4014 M20 x 130-10.9	12
19	Bolt ISO 4014 M24 x 140-10.9	12
20	Nut ISO 7042 M24-8	12
21	Prop Connector VST 48	2
23	Horizontal Ledger VST 200	4
24	Diagonal Strut VST 200/150	2
25	Diagonal Strut VST 200/100	2
26	Diagonal Strut VST 200/112.5	2



Connecting means are pre-assembled in the VST components.

The total weight of a Module VST 375 is 852.64 kg.

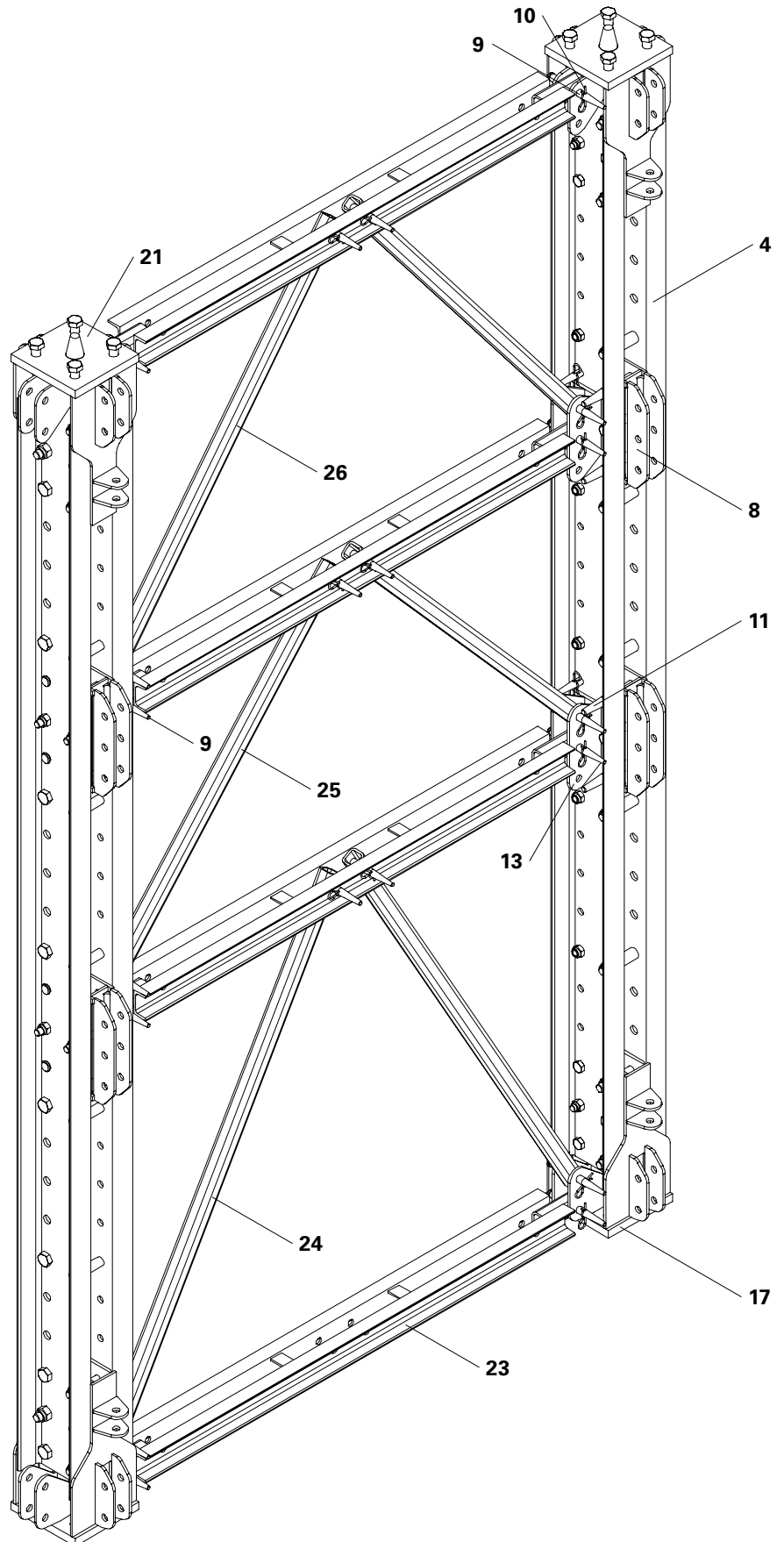

Fig. A5.01

Parts list for Module VST 525

Pos.	Name	Quantity
5	Climbing Rail RCS 498	2
8	Bracing Connector VST	6
9	Fitting Pin \varnothing 21 x 120	38
10	Cotter Pin 4/1, galv.	38
11	Fitting Pin \varnothing 26 x 120	12
12	Cotter Pin 5/1, galv.	12
13	Cross Connector VST	6
14	Bolt ISO 4014 M20 x 140-8.8	12
15	Nut ISO 7042 M20-8	24
16	Sleeve VST	6
17	Prop Base VST	2
18	Bolt ISO 4014 M20 x 130-10.9	12
19	Bolt ISO 4014 M24 x 140-10.9	12
20	Nut ISO 7042 M24-8	12
21	Prop Connector VST 48	2
23	Horizontal Ledger VST 200	5
24	Diagonal Strut VST 200/150	4
25	Diagonal Strut VST 200/100	2
26	Diagonal Strut VST 200/112.5	2



Connecting means are pre-assembled in the VST components.

The total weight of a Module VST 525 is 1123.66 kg.

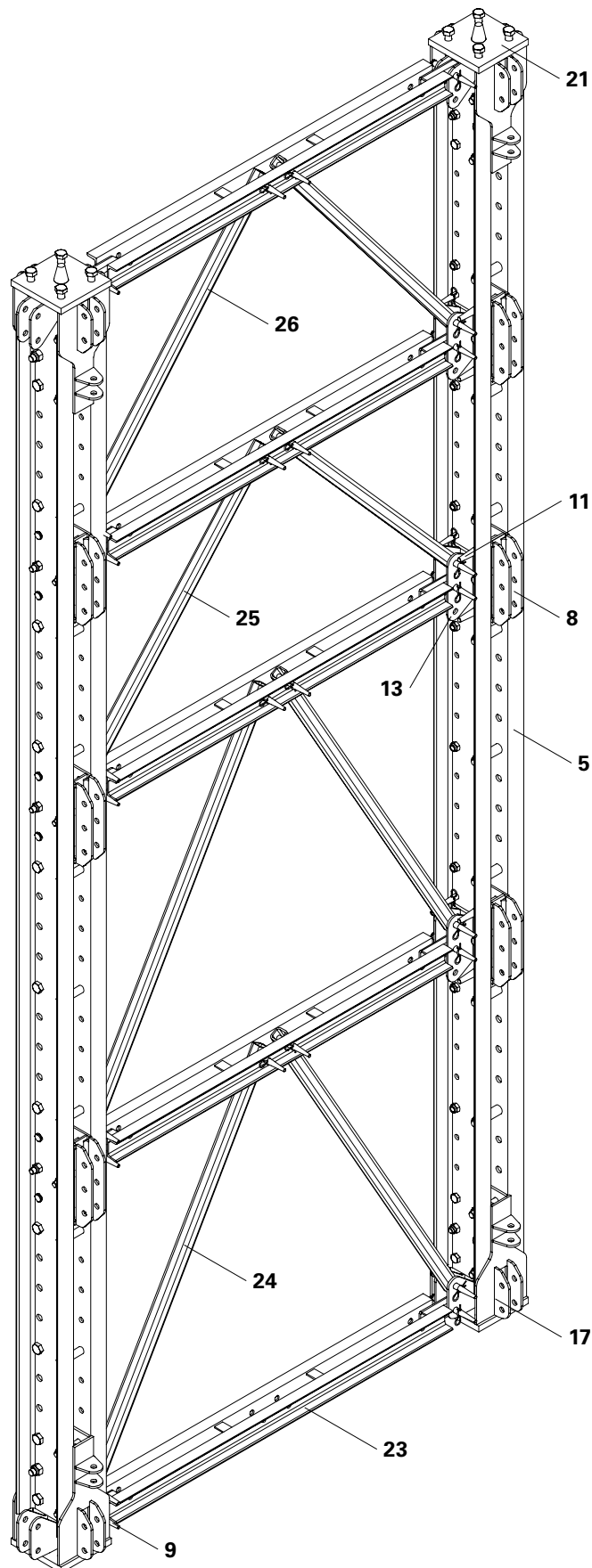

Fig. A6.01

Parts list for Module VST 775

Pos.	Name	Quantity
6	Climbing Rail RCS 748	2
8	Bracing Connector VST	10
9	Fitting Pin Ø 21 x 120	58
10	Cotter Pin 4/1, galv.	58
11	Fitting Pin Ø 26 x 120	20
12	Cotter Pin 5/1, galv.	20
13	Cross Connector VST	10
14	Bolt ISO 4014 M20 x 140-8.8	20
15	Nut ISO 7042 M20-8	32
16	Sleeve VST	10
17	Prop Base VST	2
18	Bolt ISO 4014 M20 x 130-10.9	12
19	Bolt ISO 4014 M24 x 140-10.9	12
20	Nut ISO 7042 M24-8	12
21	Prop Connector VST 48	2
23	Horizontal Ledger VST 200	7
24	Diagonal Strut VST 200/150	6
25	Diagonal Strut VST 200/100	4
26	Diagonal Strut VST 200/112.5	2



Connecting means are pre-assembled in the VST components.

The total weight of a Module VST 775 is 1601.30 kg.

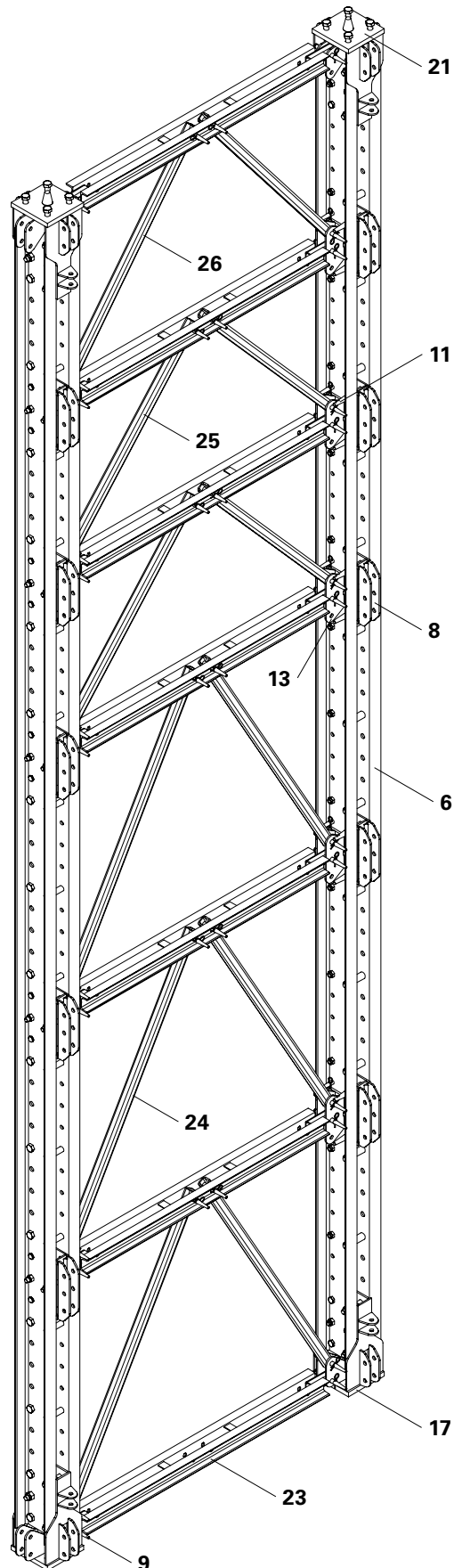

Fig. A7.01

Parts list for Module VST 1025

Pos.	Name	Quantity
7	Climbing Rail RCS 998	2
8	Bracing Connector VST	12
9	Fitting Pin \varnothing 21 x 120	68
10	Cotter Pin 4/1, galv.	68
11	Fitting Pin \varnothing 26 x 120	24
12	Cotter Pin 5/1, galv.	24
13	Cross Connector VST	12
14	Bolt ISO 4014 M20 x 140-8.8	24
15	Nut ISO 7042 M20-8	36
16	Sleeve VST	12
17	Prop Base VST	2
18	Bolt ISO 4014 M20 x 130-10.9	12
19	Bolt ISO 4014 M24 x 140-10.9	12
20	Nut ISO 7042 M24-8	12
21	Prop Connector VST 48	2
23	Horizontal Ledger VST 200	8
24	Diagonal Strut VST 200/150	12
26	Diagonal Strut VST 200/112.5	2



Connecting means are pre-assembled in the VST components.

The total weight of a Module VST 1025 is 1987.12 kg.

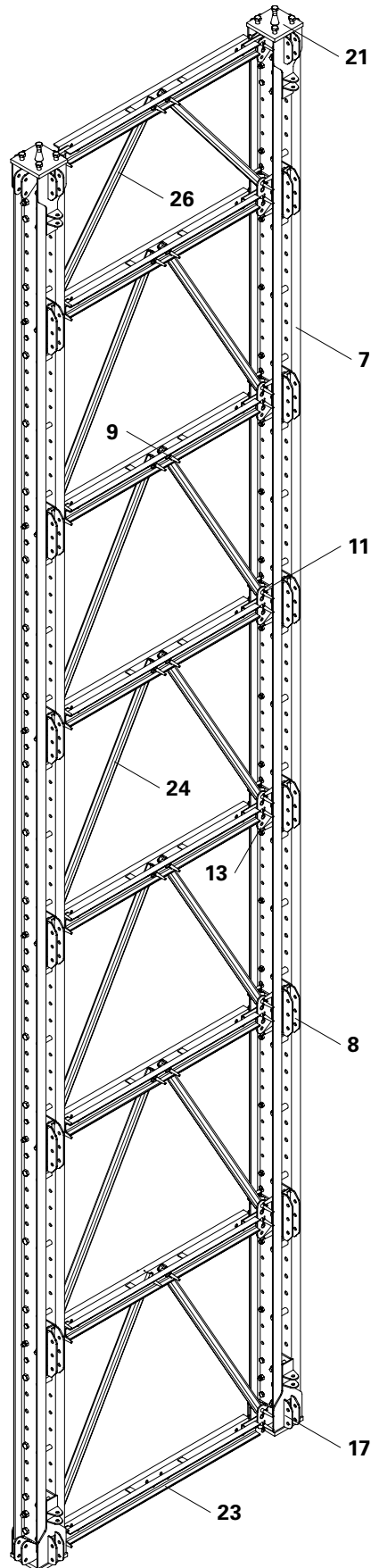

Fig. A8.01

A9 Head Spindle Frame VST

Parts list for the Head Spindle Frame VST

Pos.	Name	Quantity
9	Fitting Pin \varnothing 21 x 120	8
10	Cotter Pin 4/1, galv.	8
23	Horizontal Ledger VST 200	2
27	Diagonal Strut VST 200/62.5	2
28	Head Spindle VST 100	2

The total weight of a Head Spindle Frame VST is 424.62 kg.

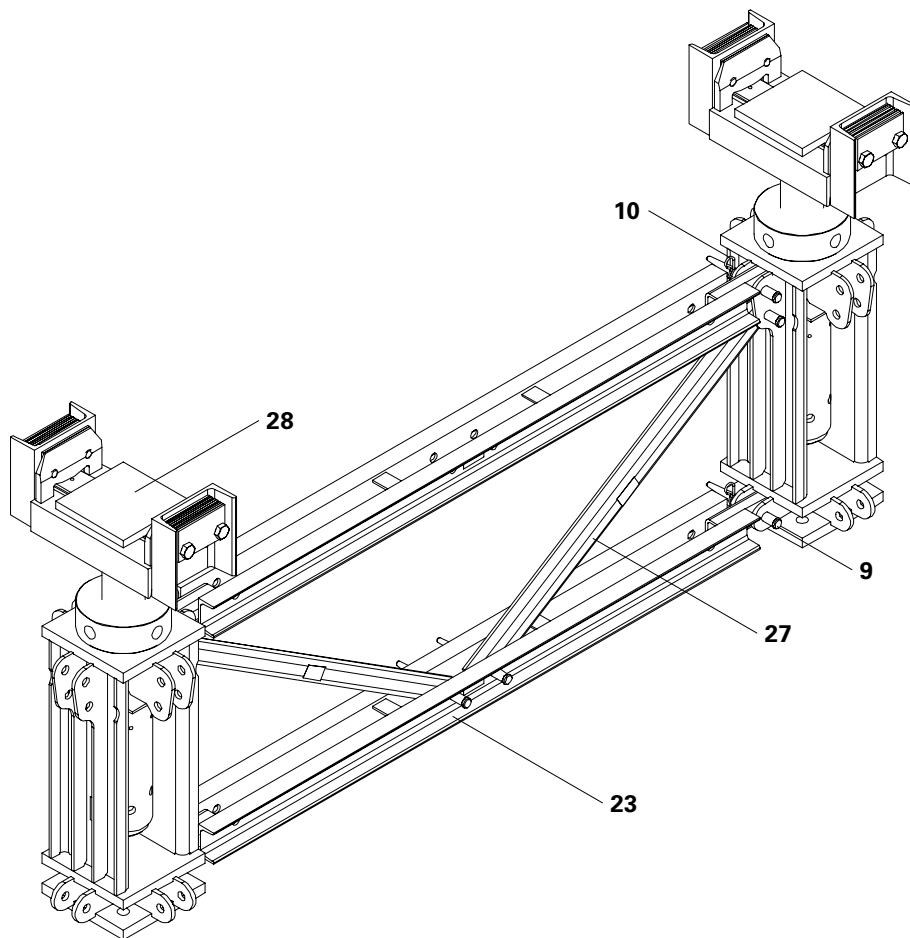

Fig. A9.01

Parts list for a Head Spindle VST 100

Pos.	Name	Quantity
28	Head Spindle VST 100	1
28.1	Fork Head	
28.2	Spindle Nut	
28.3	Spindle Sleeve	
29	Mounting Shaft VST	1
43.4	Hydraulic Cylinder	1



The maximum spindling length must not exceed 1138 mm measured from the base plate of the head spindle to the top edge of the bearing plate.



Holes in the spindle sleeve serve as a visual check. When the thread is visible through these holes, the head spindle is within the permissible range.



If the thread cannot be seen, the permissible state must be established by means of suitable measures, e.g. packing under the main beams with compensating plates or installation of Height Adjusts VST 12.5 or 25, before the tower is loaded.

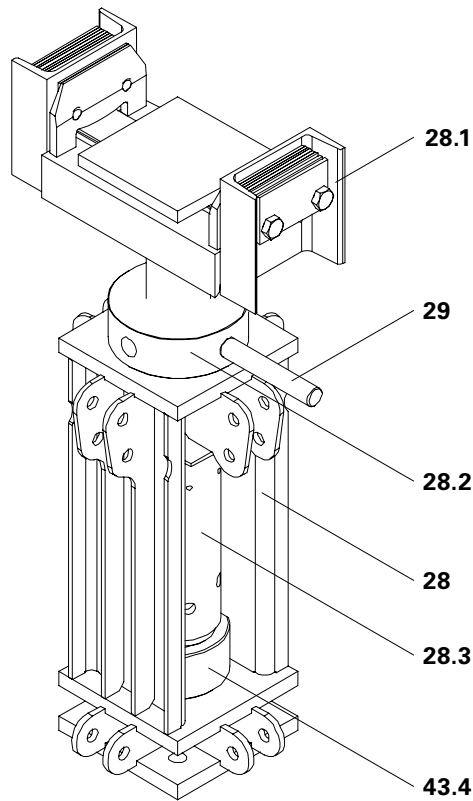

Fig. A10.01

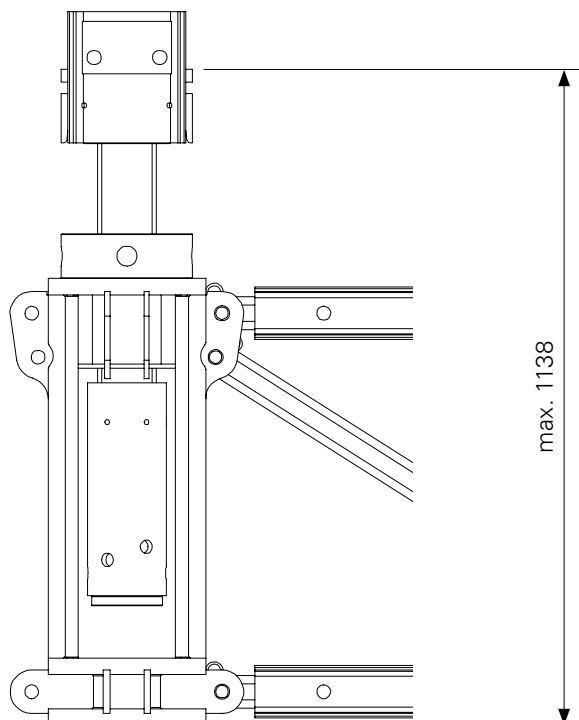

Fig. A10.01a

A11 VST Tower Configuration 1

Tower configuration 2.0 x 2.0 m

Pos. Name

- 9 Fitting Pin Ø 21 x 120
- 10 Cotter Pin 4/1, galv.
- 23 Horizontal Ledger VST 200
- 24 Diagonal Strut VST 200/150
- 25 Diagonal Strut VST 200/100
- 26 Diagonal Strut VST 200/112.5
- 27 Diagonal Strut VST 200/62.5

Total weight for one VST Tower (configuration 1)

Name	Total weight (kg)
Tower 125	912.80
Tower 175	1,324.52
Tower 275	1,579.64
Tower 375	2,103.28
Tower 525	2,764.52
Tower 775	3,945.40
Tower 1025	4,861.48
Head Spindle Frame VST	1,010.48

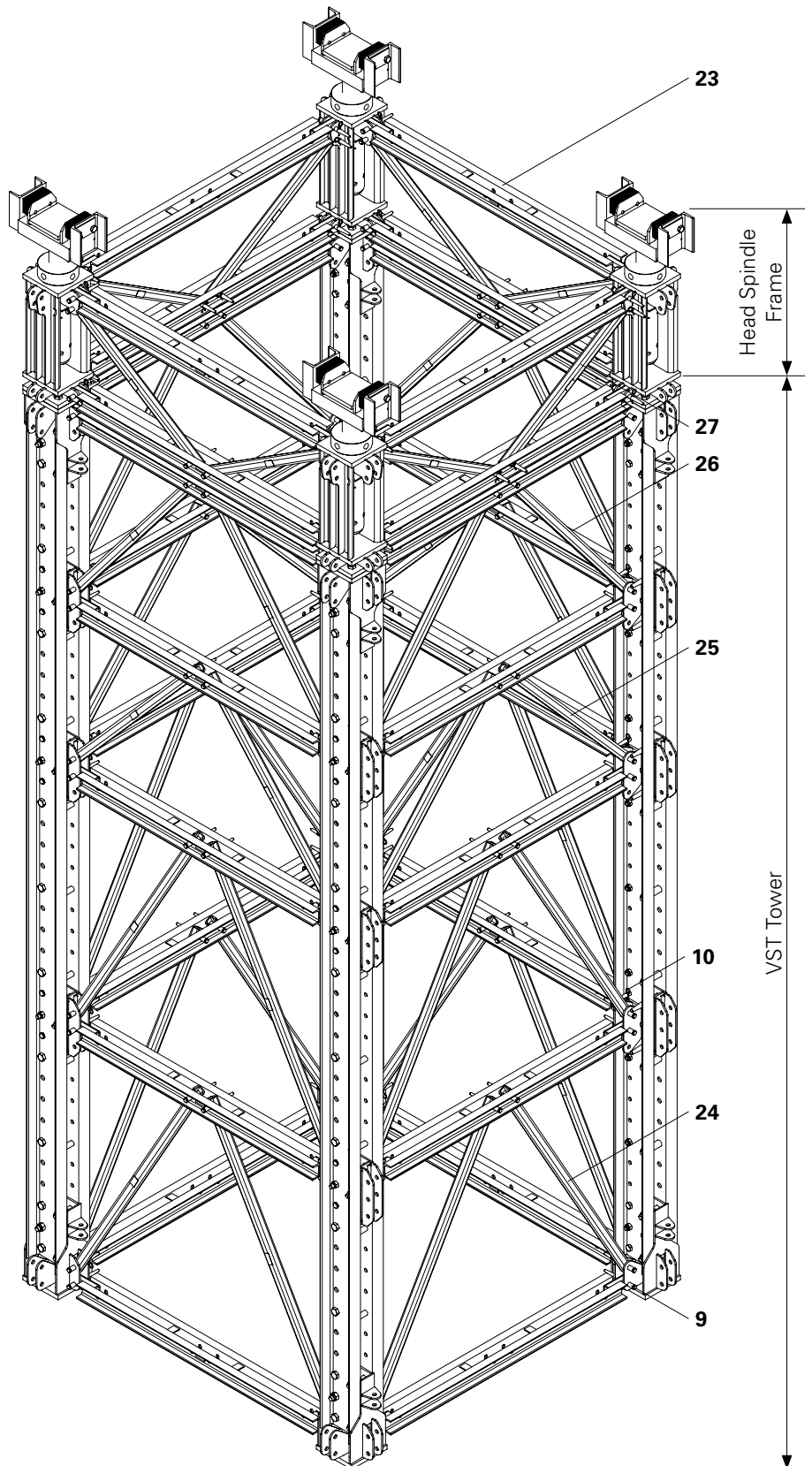

Fig. A11.01

A12 VST Tower Configuration 2

Tower configuration 2.0 x 1.0 – 4.5 m

Pos. Name

- | | |
|-----------|------------------------|
| 9 | Fitting Pin Ø 21 x 120 |
| 10 | Cotter Pin 4/1, galv. |
| 30 | Heavy-Duty Spindle SLS |



Connecting means for Heavy-Duty Spindles SLS must be ordered separately.

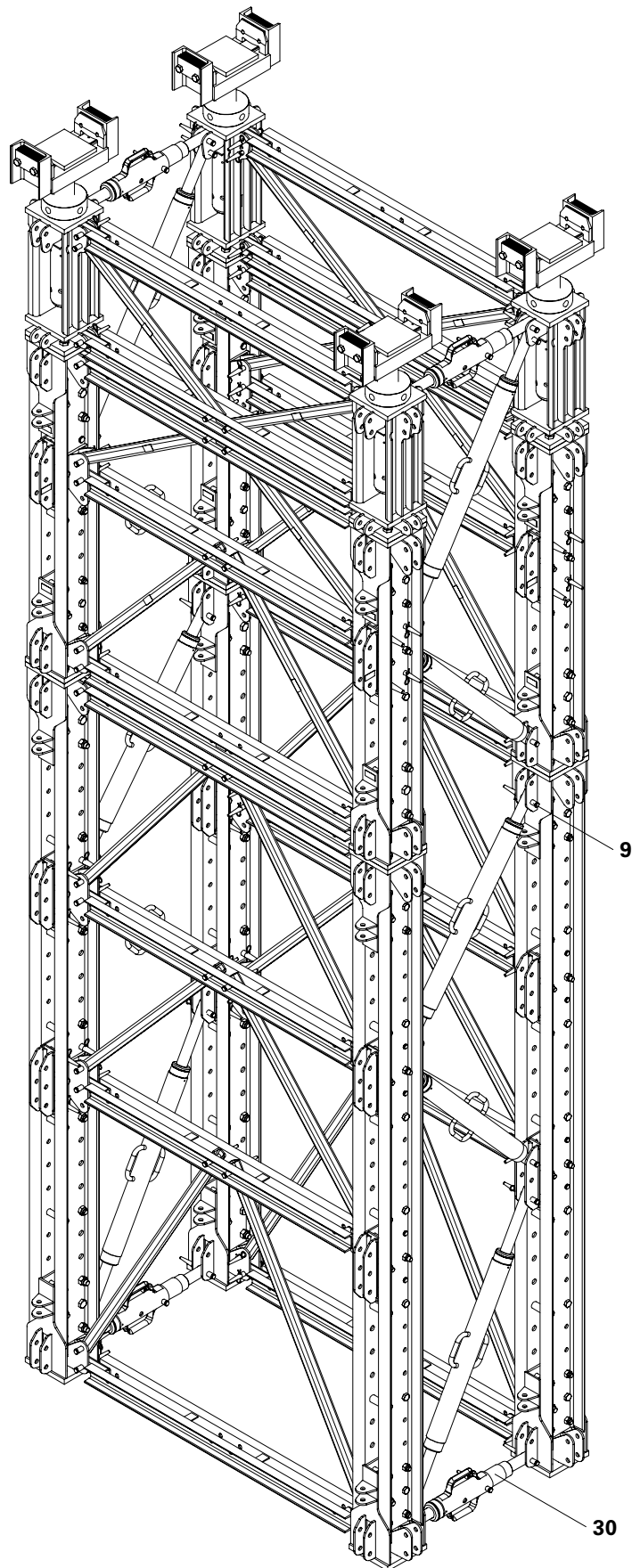

Fig. A12.01

A13 VST Tower Configuration 3

Tower configuration
1.25 – 6.5 x 1.0 – 4.5 m

Pos. Name

- | | |
|----|------------------------------------|
| 9 | Fitting Pin \varnothing 21 x 120 |
| 10 | Cotter Pin 4/1, galv. |
| 30 | Heavy-Duty Spindle SLS |
| 33 | Steel Waler Universal SRU U120 |
| 34 | Adapter VST-SRU |



Connecting means for Heavy-Duty Spindles SLS and Steel Waler Universal SRU U120 must be ordered separately.

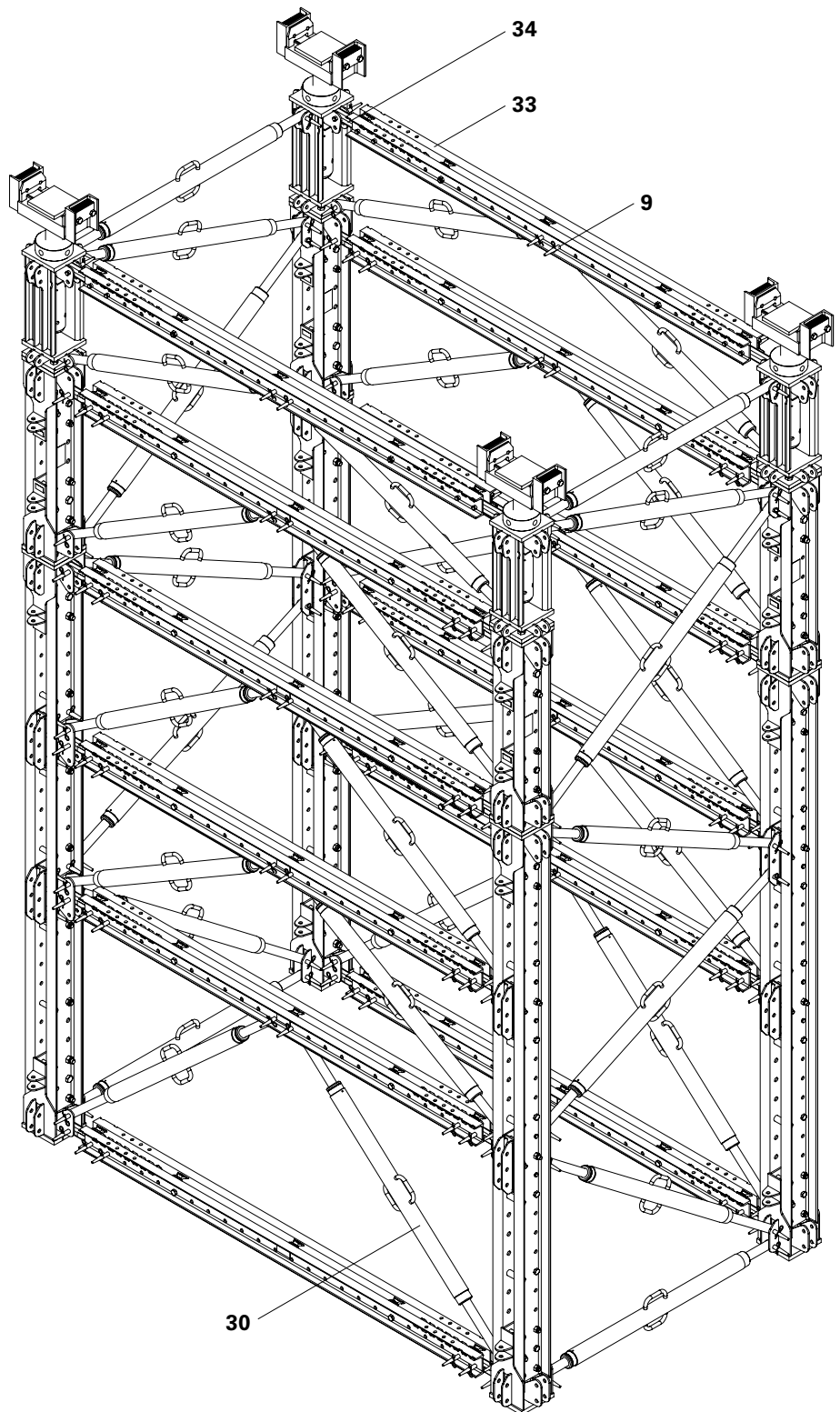

Fig. A13.01

A14 VST Tower Configuration 4

Tower configuration 1.25 – 6.5 x 1.25 – 6.5 m

Pos. Name

9	Fitting Pin Ø 21 x 120
10	Cotter Pin 4/1, galv.
30	Heavy-Duty Spindle SLS
33	Steel Waler Universal SRU U120
34	Adapter VST-SRU



Connecting means for Heavy-Duty Spindles SLS and Steel Waler Universal SRU U120 must be ordered separately.

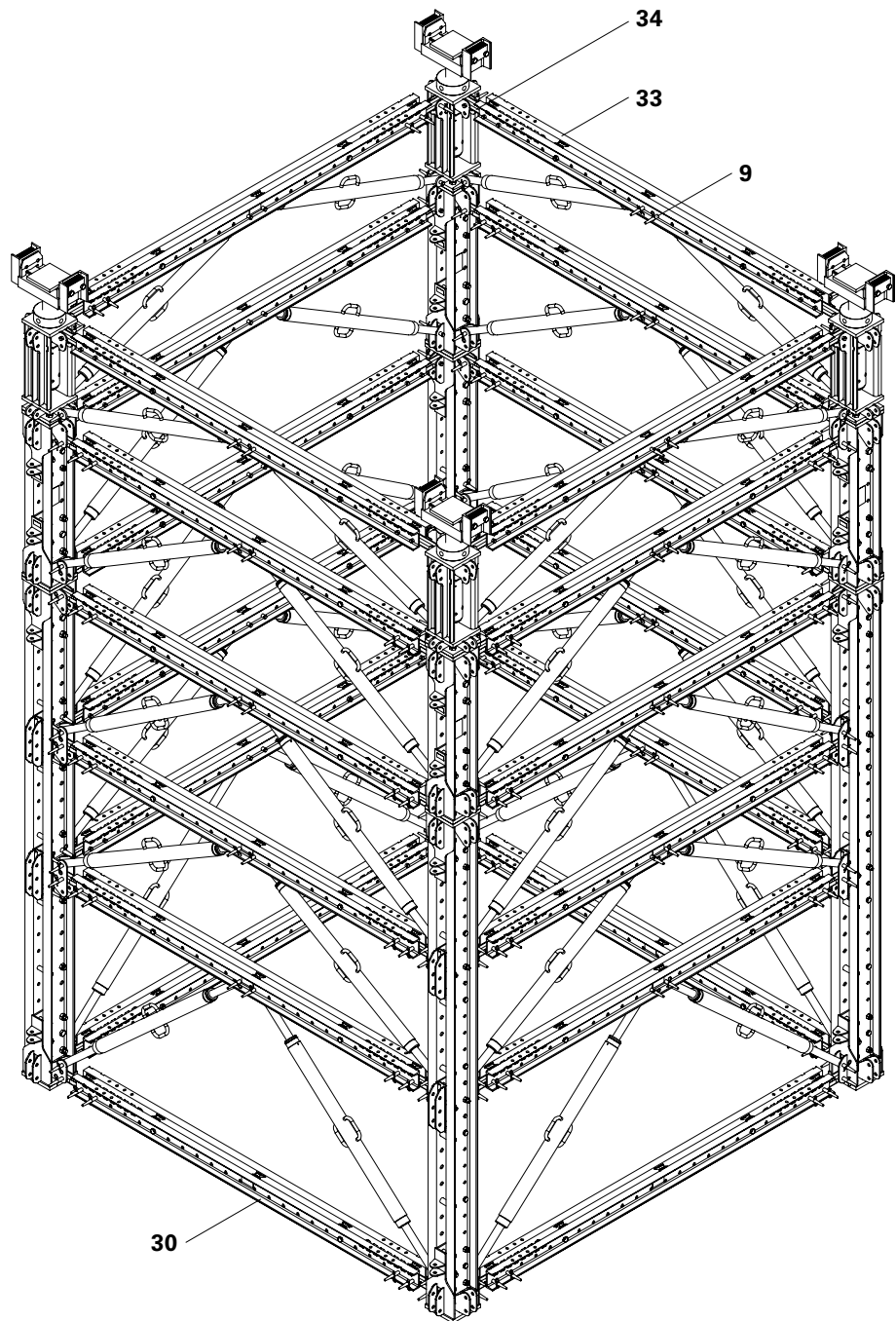

Fig. A14.01

A15 Arrangement of the Height Adjusts



When arranging the Height Adjusts VST 25 and VST 12.5, the following must be observed:

- Maximum one Height Adjust VST 12.5 (44) and one Height Adjust VST 25 (45) may be placed under the head spindle (28).
- Additional Height Adjusts VST 12.5 (44) and Height Adjusts VST 25 (45) must be arranged individually between the modules positioned below.

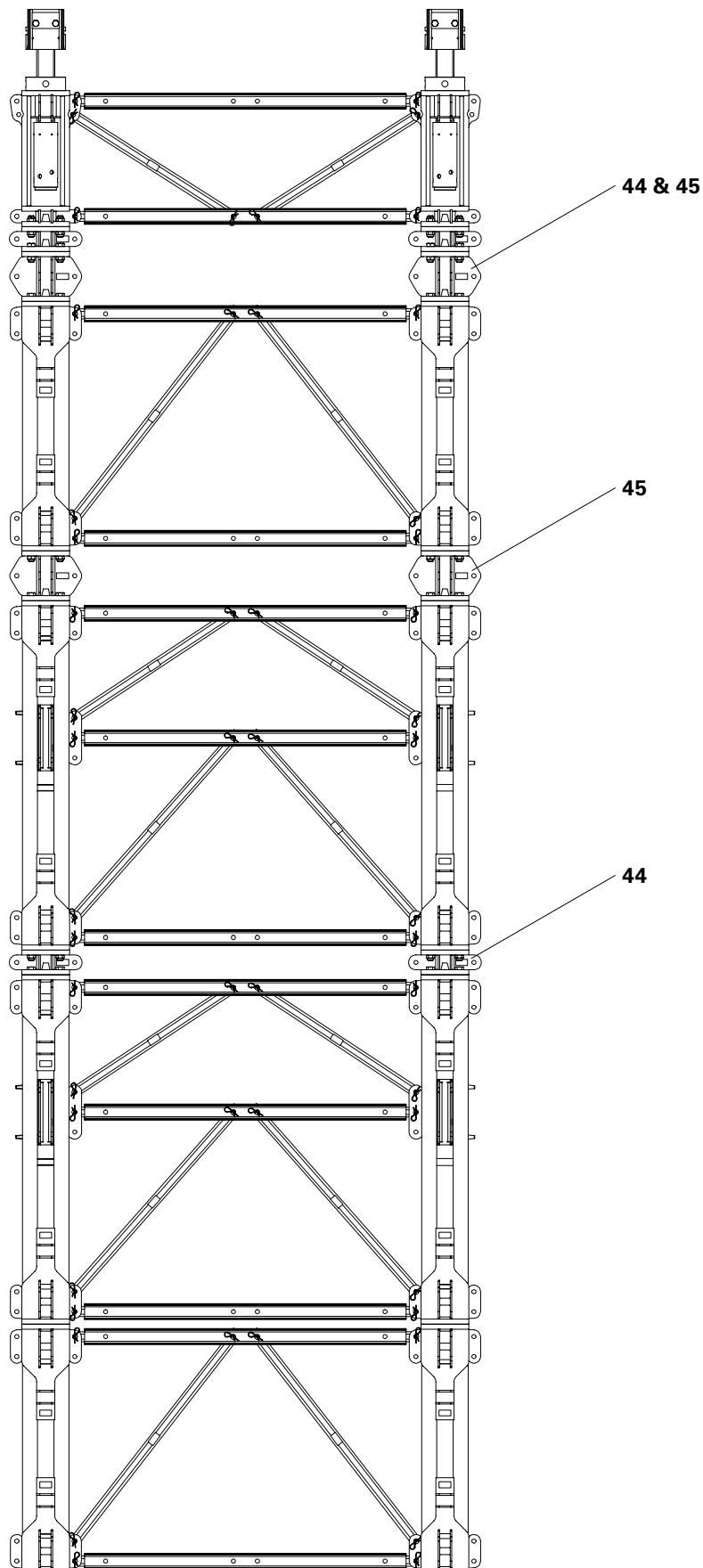

Fig. A15.01

A16 Assembly of two Cross Connectors VST on the RCS / Bracing Connector VST

Components

Pos. Name

2 - 7	Climbing Rail RCS 148 - 998
8	Bracing Connector VST
13	Cross Connector VST
15	Nut ISO 7042 M20-8, galv.
16	Sleeve VST, galv.
37	Cyl. Bolt ISO 4762 M20x150-8.8, galv.

Assembly

1. Insert Sleeve VST, galv. (16) in the Bracing Connector VST (8).
2. Position 2x Cross Connector VST (13) on the Climbing Rail RCS 148 (2)*.
3. Mount Cross Connectors VST (13) to the Climbing Rail RCS 148 (2)* by means of Cyl. Bolt ISO 4762 (37) and Nut ISO 7042 (15).

* Depending on the module size, other climbing rails are used.



For assembly of the Bracing Connector (8), see Section B2.

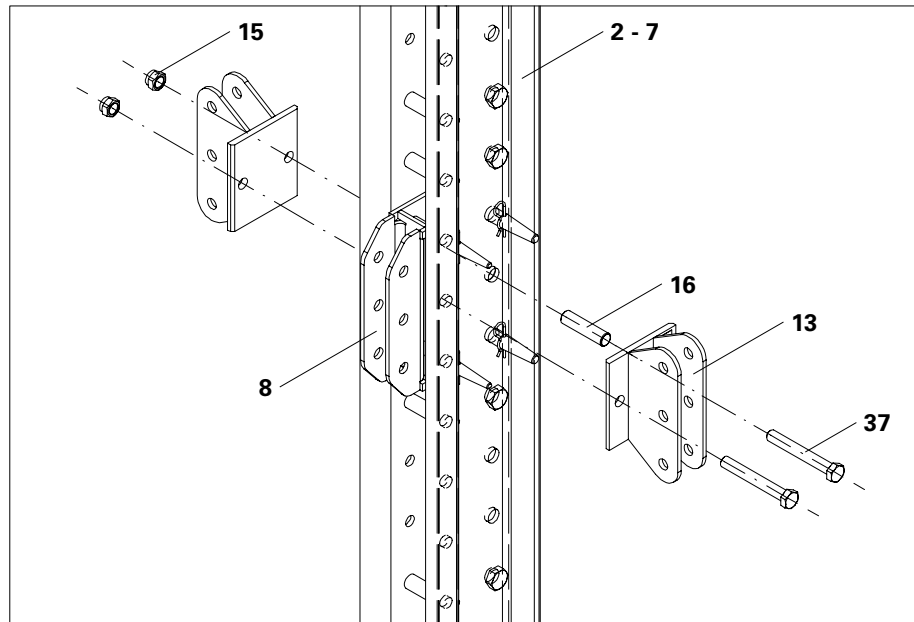

Fig. A16.01

Components

Pos. Name

8	Bracing Connector VST
9	Fitting Pin \varnothing 21 x 120
10	Cotter Pin 4/1, galv.
13	Cross Connector VST
33	Steel Waler Universal SRU U120
34	Adapter VST-SRU

Assembly

1. Mount Adapter VST-SRU (34) on Steel Waler SRU U120 (33) using 2x Fitting Pins \varnothing 21 x 120 (9) and secure with Cotter Pins 4/1, galv.
2. Mount Adapter VST-SRU (34) on the Cross Connector VST (13) in the centre using 1x Fitting Pin \varnothing 21 x 120 (9) and secure with Cotter Pin 4/1, galv.

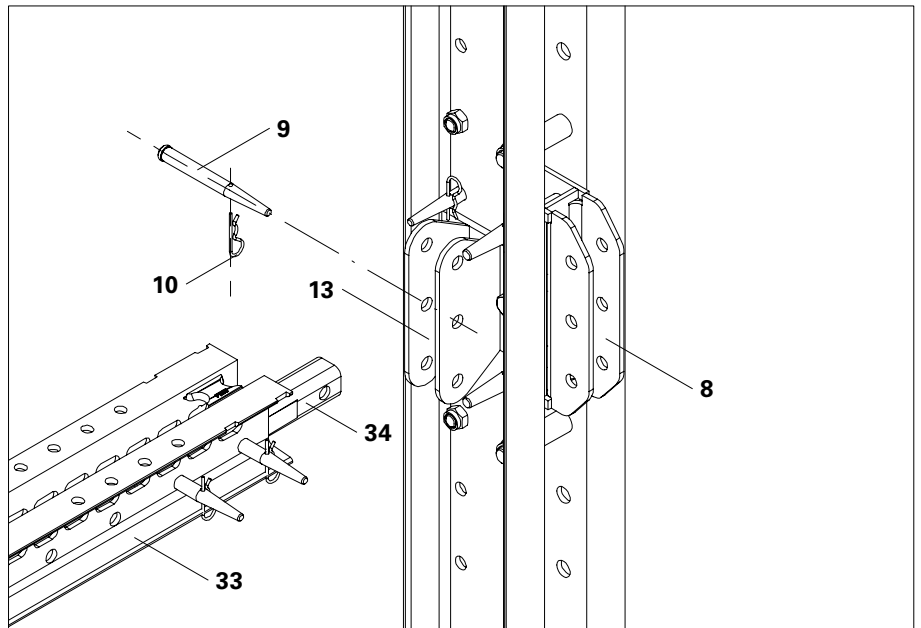

Fig. A17.01

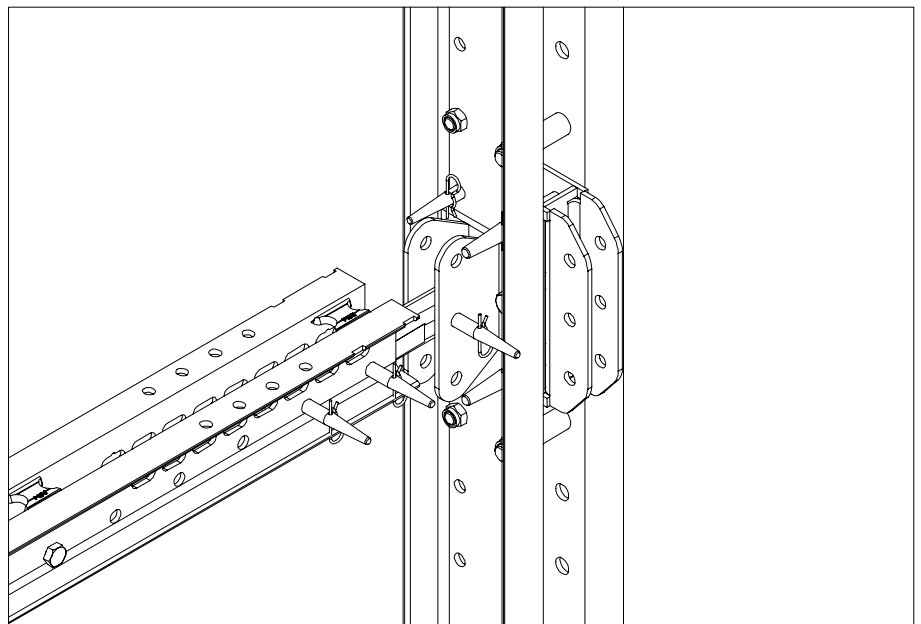

Fig. A17.02



Project-specific planning is required for the working platforms.

Components

Pos. Name

9	Fitting Pin \varnothing 21 x 120
10	Cotter Pin 4/1, galv.
38	Connector UP / VST
39	Bolt \varnothing 20 x 140, galv. PERI UP Rosett Flex components

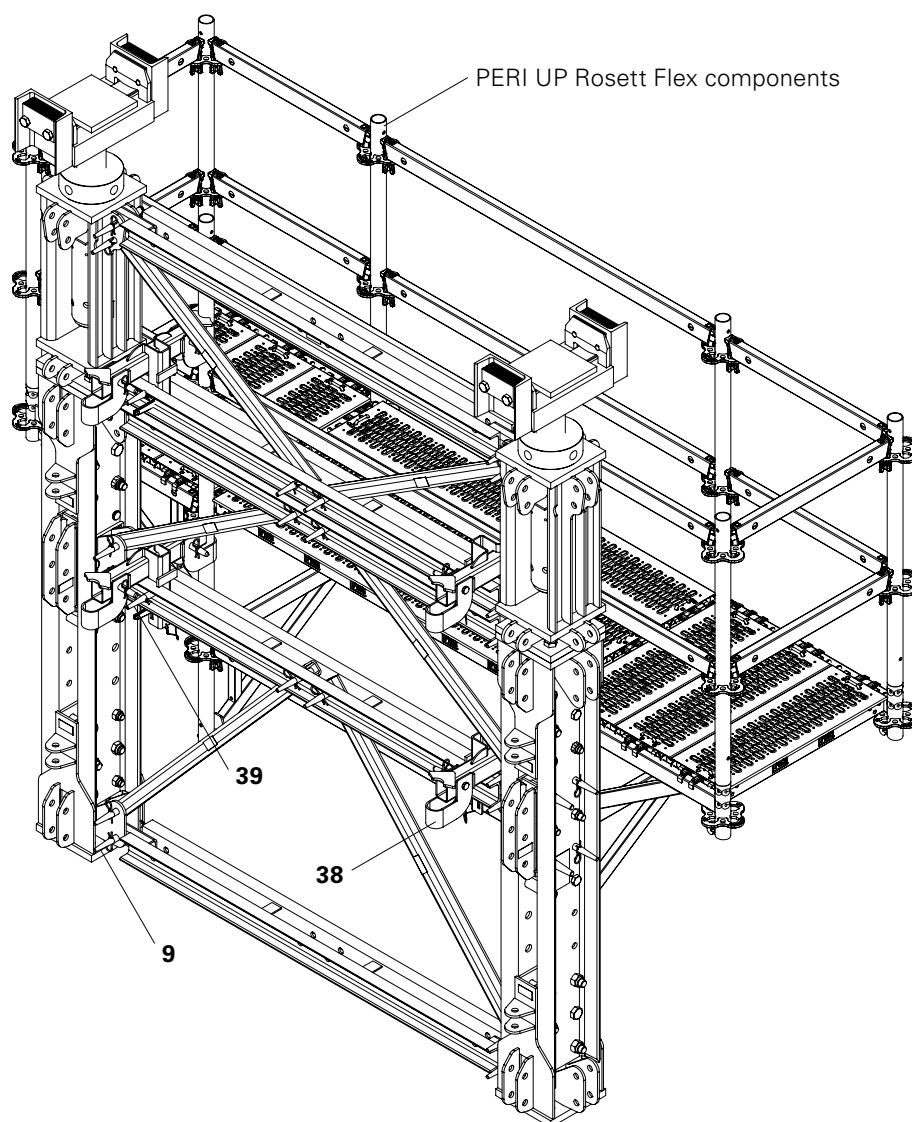

Fig. A18.01

Connector UP-VST

Pos. Name

- | | |
|------|------------------------------------|
| 9 | Fitting Pin \varnothing 21 x 120 |
| 10 | Cotter Pin 4/1, galv. |
| 38 | Connector UP-VST |
| 38.1 | Retaining Lug |
| 39 | Bolt \varnothing 20 x 140, galv. |
| 40 | Wedge K, galv. |

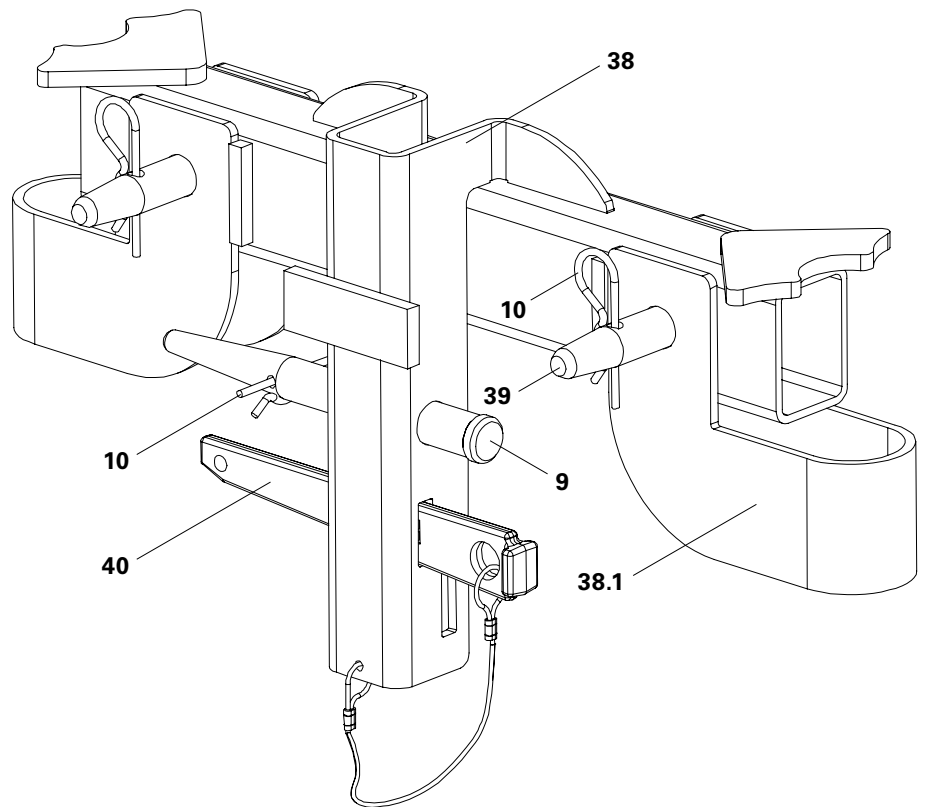

Fig. A18.02

Components

Pos. Name

9	Fitting Pin \varnothing 21 x 120
10	Cotter Pin 4/1, galv.
41	Leg Connector VST 200/37.5
42	Horizontal Connector VST 37.5

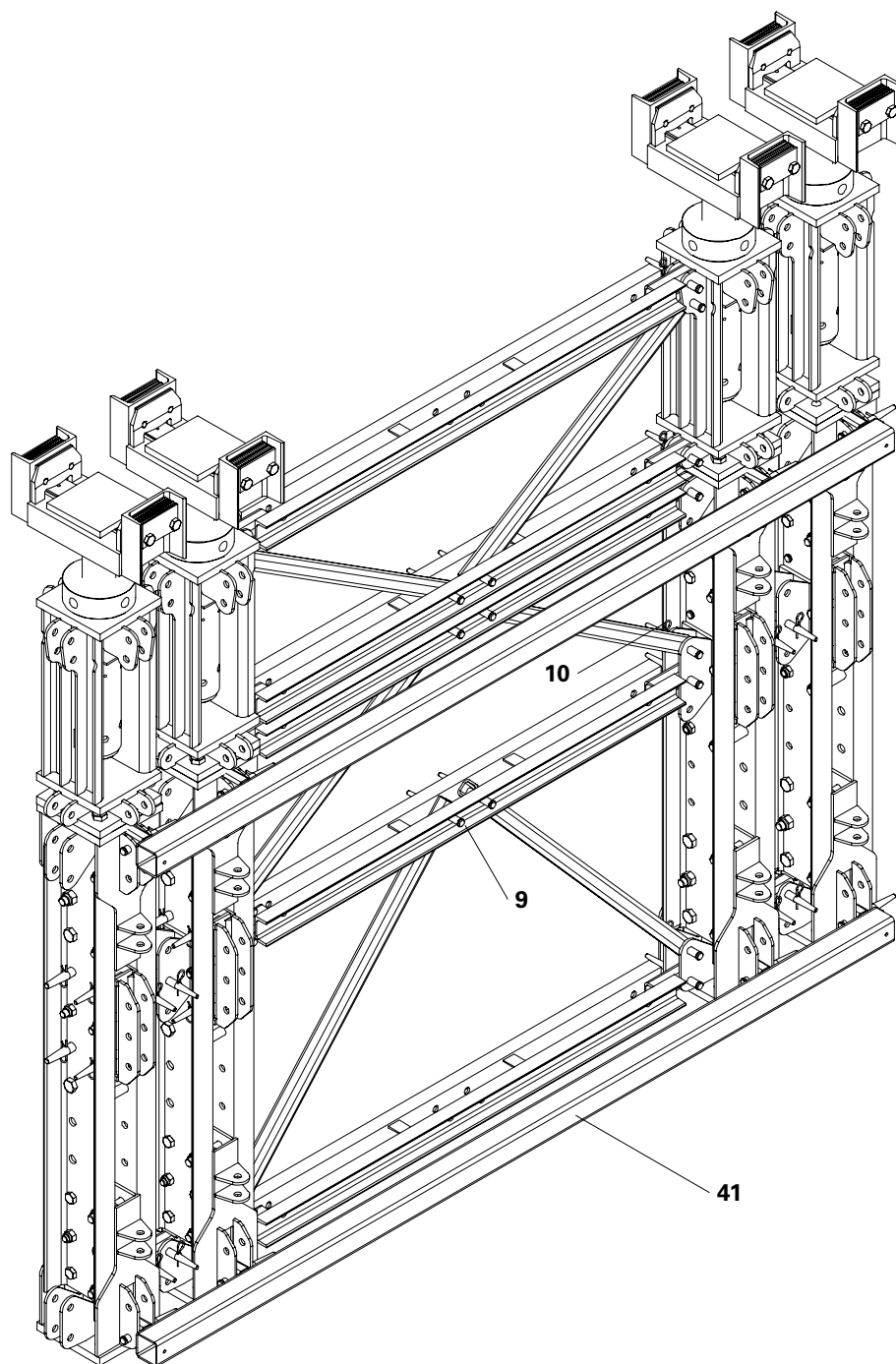

Fig. A19.01

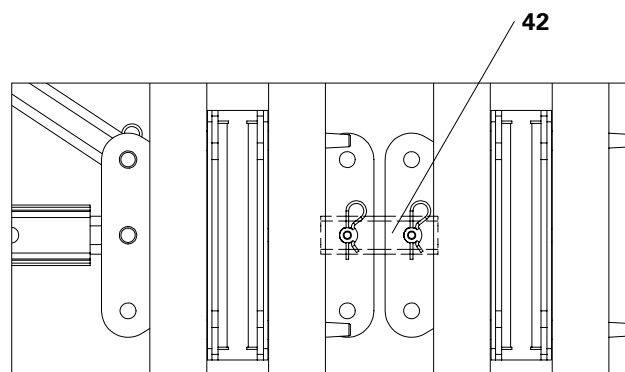

Fig. A19.01a



Follow Instructions for Use for the Hydraulic Head Spindle Device VST.



Fig. A20.02

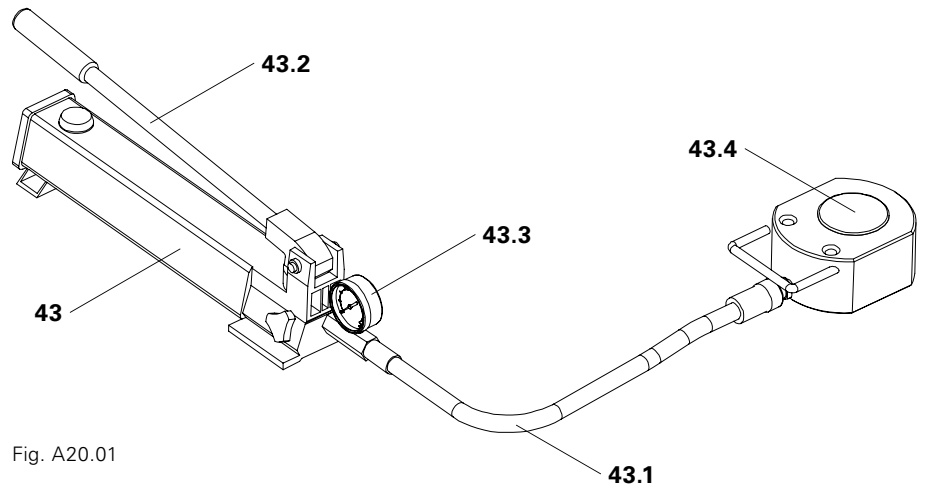

Fig. A20.01

Components

Pos. Name

-
- | | |
|-------------|-----------------------|
| 43 | Hydraulic Unit VST 75 |
| 43.1 | Hydraulic Hose |
| 43.2 | Hand Pump |
| 43.3 | Manometer |
| 43.4 | Hydraulic Cylinder |
-

Operating state: mounting



Assembly platforms must not be used as storage areas.

- Rough pre-adjustment.
- Assembly of the upper construction.
- Fine adjustment of the upper construction with the Hydraulic Head Spindle Device VST.

Operating state: lowering and dismantling



Assembly platforms must not be used as storage areas.

- After the upper construction has reached the required load-bearing capacity, the VST Heavy-Duty Shoring Tower is then lowered according to specifications laid down by the responsible structural engineer.
- Dismantling of additional load-bearing elements according to project-specific planning.



A project-specific lifting and lowering plan, as well as detailed static verification is always required.

Lifting or lowering operations only take place if a competent person has given the go-ahead and the upper construction has sufficient load-bearing capacity.

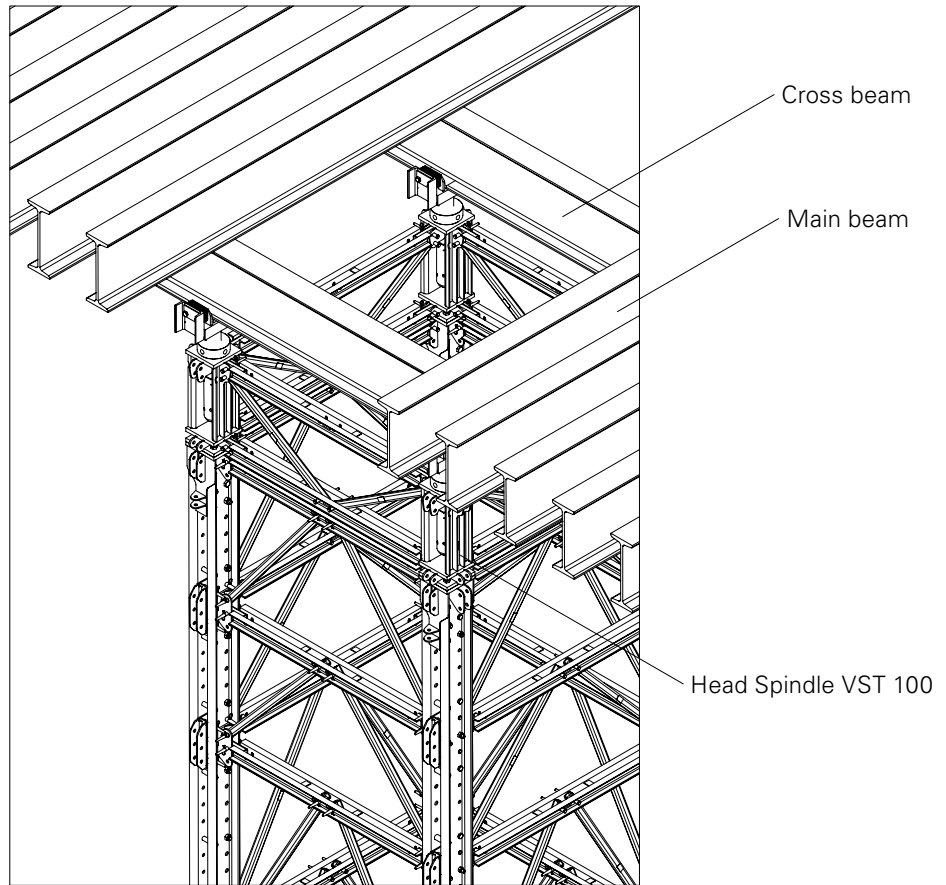

Fig. B1.01

Preparation of the RCS Rail

1. Supporting the RCS Rails with timbers or the like ($h \geq 10$ cm) on a flat surface.
2. Remove the first pair of bolts (M20 and M24) from the climbing rail.
3. Remove the external spacers. (Fig. B2.01a)



- Check the assembly position of the Prop Base VST 48.
- After the bolts have been removed, five rows of holes must then be free up to the next pair of bolts. (Fig. B2.01a)

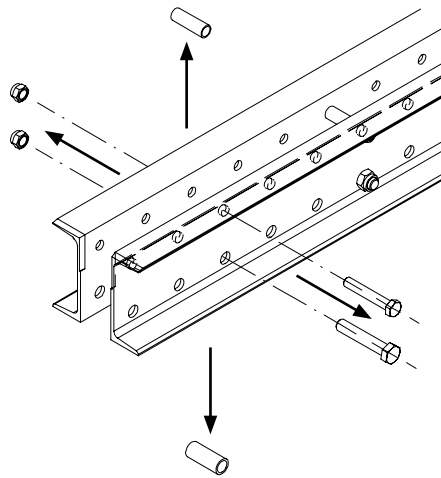

Fig. B2.01a

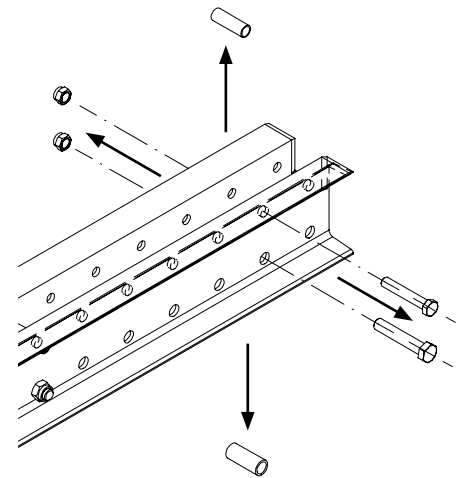

Fig. B2.01b

4. Remove the last pair of bolts (M20 and M24) from the climbing rail.
5. Remove the external spacers. (Fig. B2.01b)



- Check the assembly position of the Prop Connector VST 48.
- After the bolts have been removed, six rows of holes must be free up to the next pair of bolts. (Fig. B2.01b)

Preparation of the Prop Base VST 48

1. Remove all 6 bolt connections from the Prop Base VST 48 (17). (Fig. B2.02)

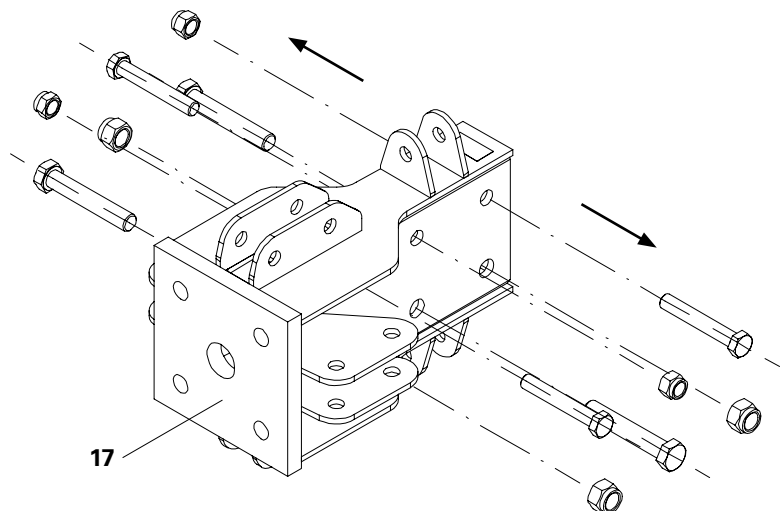

Fig. B2.02

Preparation of the Prop Connector VST 48

1. Remove all 6 bolt connections from the Prop Connector VST 48 (21). (Fig. B2.03)

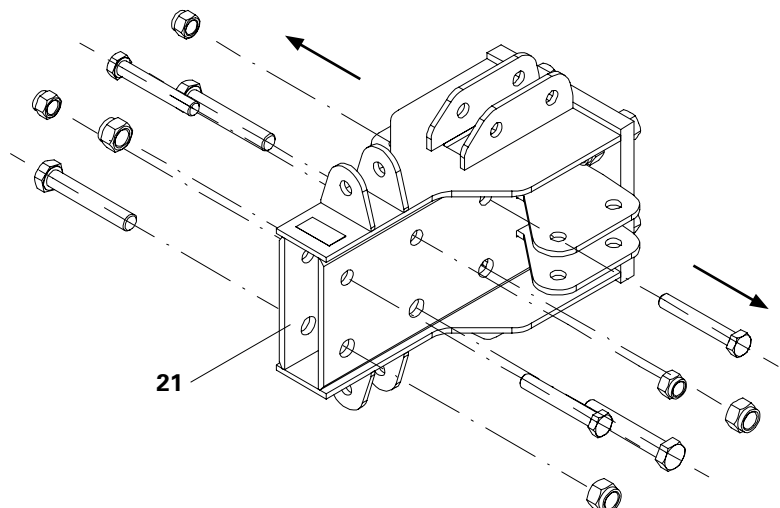

Fig. B2.03

Prop Connector VST 48



Risk of crushing fingers when inserting.



Assembly position must be observed.
(Six rows of holes free)

Bolting the Prop Connector VST 48 to the Climbing Rail RCS

1. Insert Prop Connector VST 48 (21) into the Climbing Rail RCS (3)* on the side with the six free rows of holes.
2. Insert 1 x Bolt ISO 4014 M20 (18) from the left-hand side.
3. Insert 2 x Bolts ISO 4014 M20 (18) from the right-hand side.
4. Attach Nuts ISO 7042 M20 (15) and tighten the connections.
5. Insert 1 x Bolt ISO 4014 M24 (19) from the right-hand side.
6. Insert 2 x Bolts ISO 4014 M24 (19) from the left-hand side.
7. Attach Nuts ISO 7042 M24 (20) and tighten the connections.

* Depending on the module size, other Climbing Rails RCS have to be used.

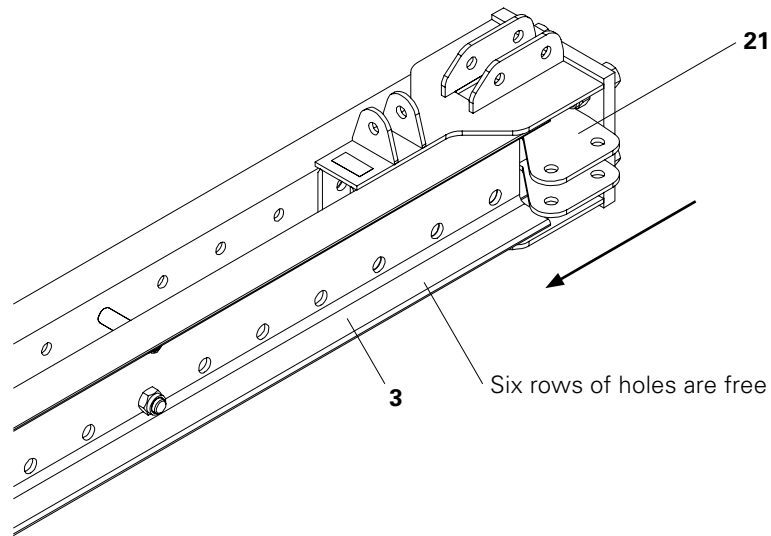

Fig. B2.04a

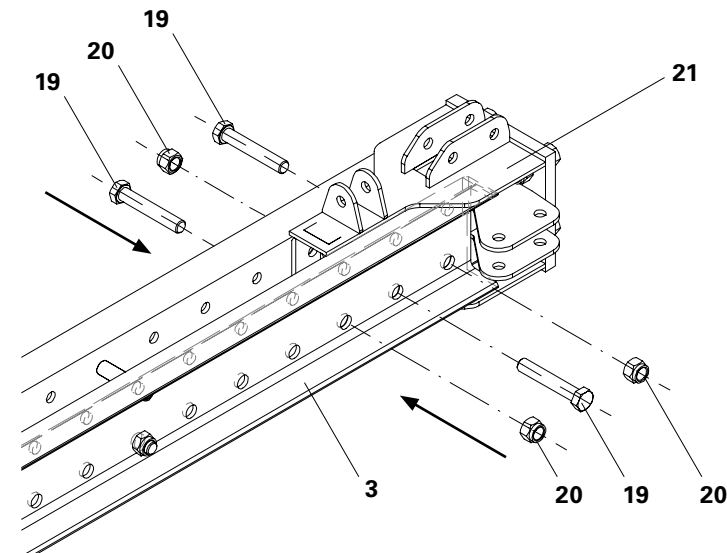

Fig. B2.04b

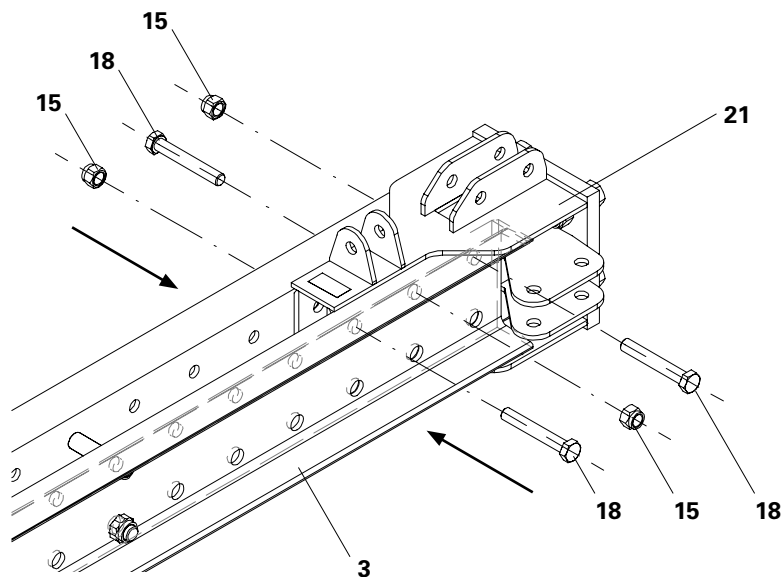

Fig. B2.04c

Prop Base VST 48



Risk of crushing fingers when inserting.



Assembly position must be observed.
(Five rows of holes free)

Bolting the Prop Base VST 48 to the Climbing Rail RCS

1. Insert Prop Base VST 48 (17) into the Climbing Rail RCS 248 (3)* on the side with the five free rows of holes.
2. Insert 1 x Bolt ISO 4014 M20 (18) from the left-hand side.
3. Insert 2 x Bolts ISO 4014 M20 (18) from the right-hand side.
4. Attach Nuts ISO 7042 M20 (15) and tighten the connections. (Fig. B2.05b)
5. Insert 1 x Bolt ISO 4014 M24 (19) from the right-hand side.
6. Insert 2 x Bolts ISO 4014 M24 (19) from the left-hand side.
7. Attach Nuts ISO 7042 M24 (20) and tighten the connections. (Fig. B2.05c)

* Depending on the module size, other Climbing Rails RCS must be used.

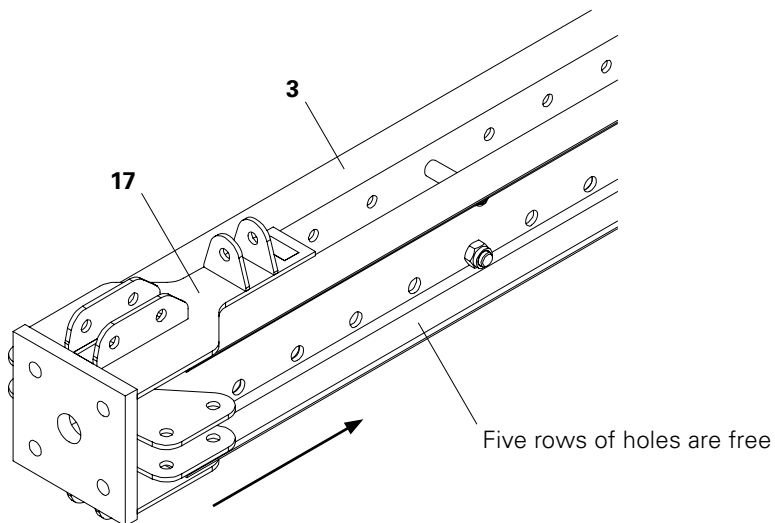

Fig. B2.05a

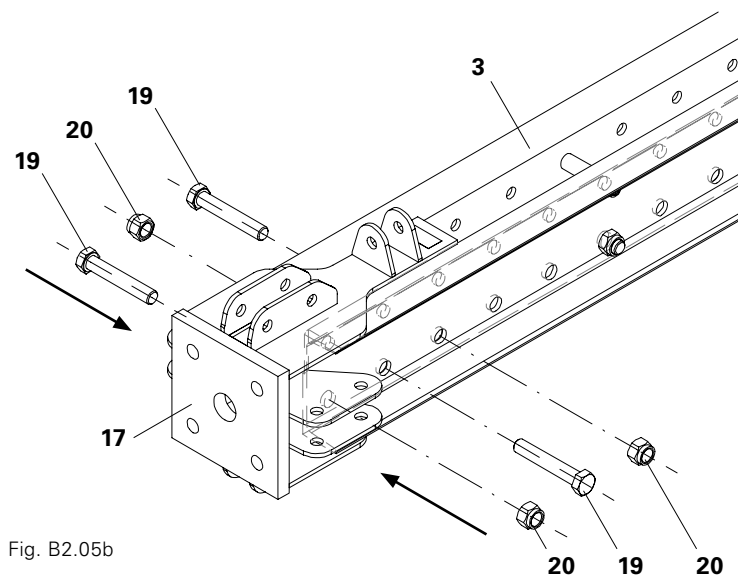

Fig. B2.05b

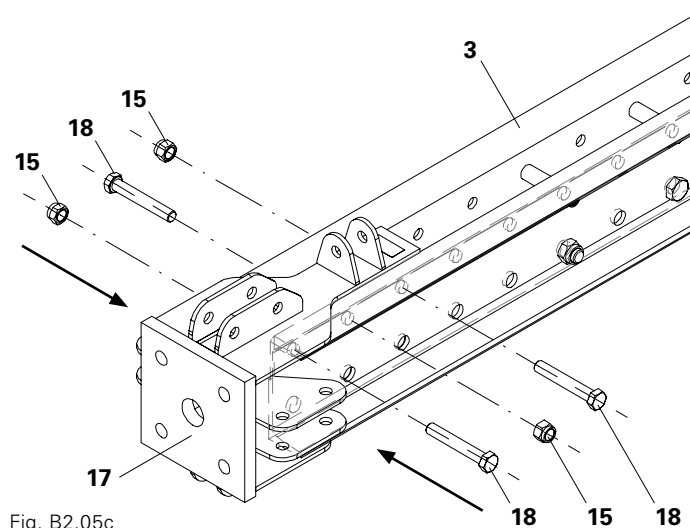

Fig. B2.05c

Bracing Connector VST



Risk of crushing fingers when inserting.



- The Bracing Connector VST (8) must be connected at the height of the Horizontal Ledger VST (23).
- The positions are indicated through the distances in Section A1 Overview.

Mounting the Bracing Connector VST (8) on the Climbing Rail RCS

1. Insert the Bracing Connector VST (8) into the Climbing Rail RCS.
2. Centre the Bracing Connector VST (8) with Sleeve VST (16) (included in the Cross Connector VST).
3. Connect the Bracing Connector VST (8) with 2x Fitting Pins \varnothing 21 mm (9) and 2x Fitting Pins \varnothing 26 mm (11) respectively.
4. Secure Fitting Pins \varnothing 21 mm (9) with Cotter Pins 4/1, galv. and Fitting Pins \varnothing 26 mm (11) with Cotter Pins 5/1, galv.

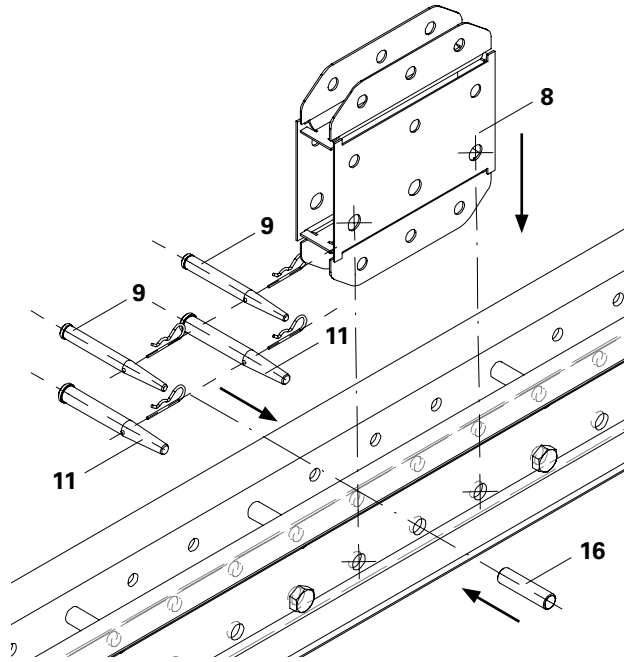

Fig. B2.06a

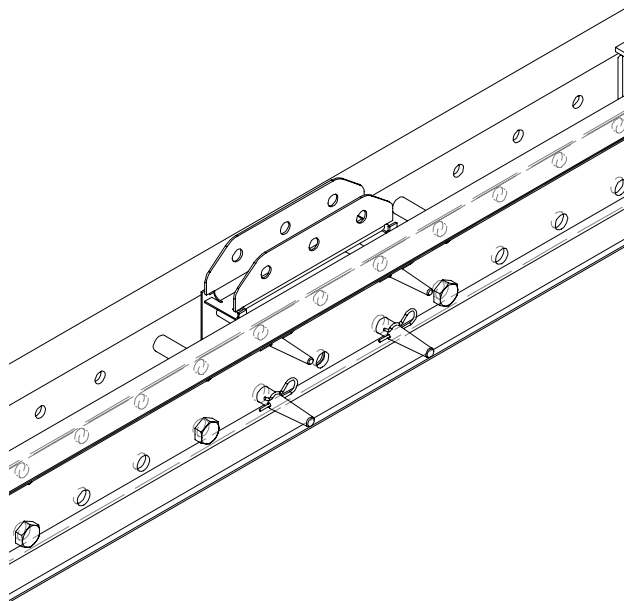

Fig. B2.06b

Cross Connector VST

Mounting of the Cross Connector VST (13) on the Climbing Rail RCS

1. Position the Cross Connector VST (13) on the axis of the Bracing Connector VST (8).
2. Insert 2 x Bolts ISO 4014 M24 (19).
3. Attach Nuts ISO 7042 M24 (20) and tighten the connections.

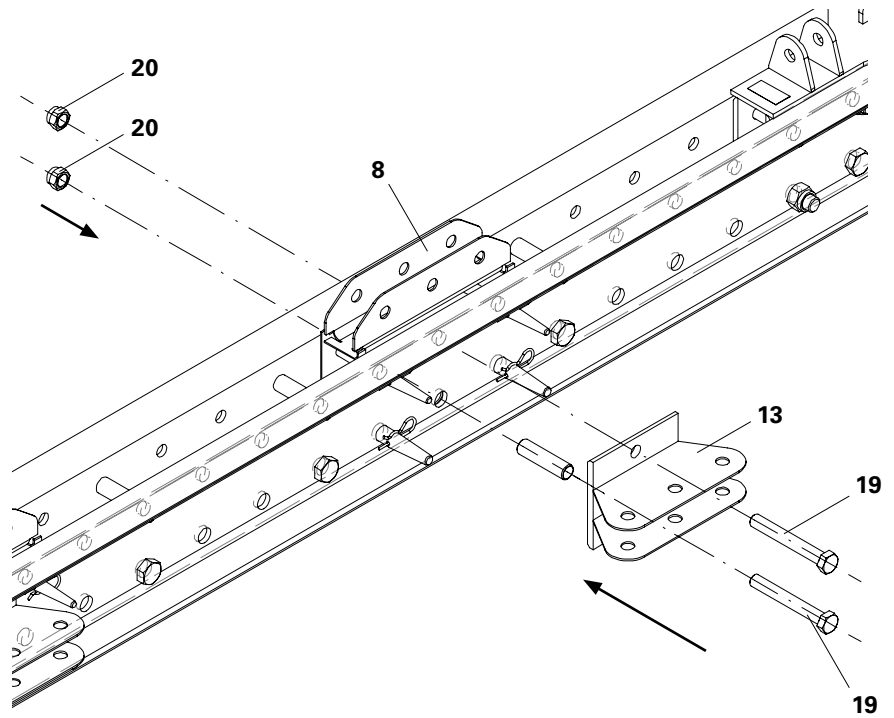

Fig. B2.07a

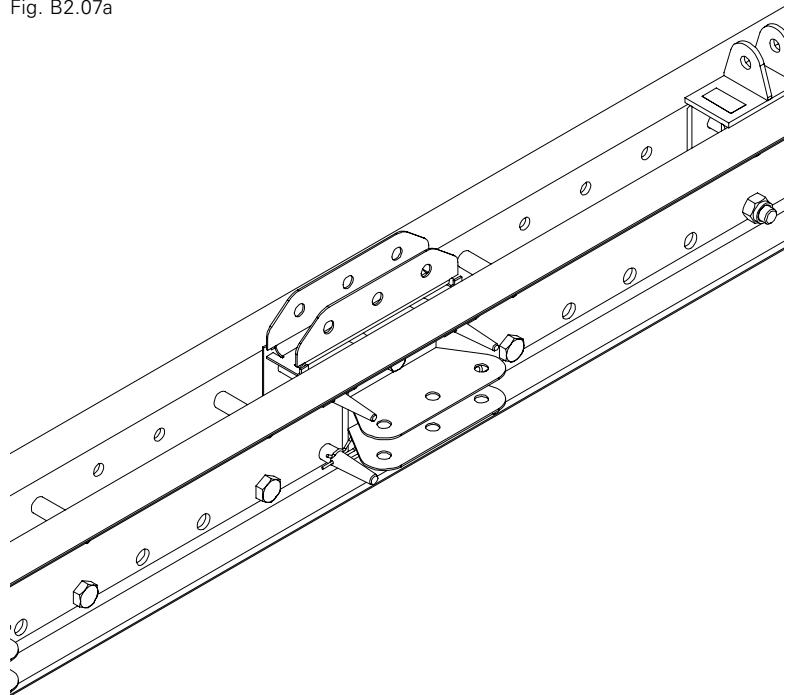

Fig. B2.07b

Horizontal Ledger VST 200



- **Horizontal Ledger VST 200 is always bolted to the Cross Connector VST.**
- **Bracing above the Bracing Connector VST is not permitted.**
- Position VST Legs at a distance of 2.0 m to each other on a flat assembly surface.
- Firstly, the Horizontal Ledgers VST 200 (23) are mounted on the Prop Connector VST (21) and the Prop Base VST (17). This results in the planned spacing for the legs.
- The two outer holes are used for the Prop Connector VST (21) and Prop Base VST (17) respectively.
- The centre holes are used for the Cross Connector VST (13).

Mounting the Horizontal Ledger VST 200 on the VST Legs

1. Insert the Horizontal Ledger VST 200 (23) into the Prop Base VST (17).
2. Connect the Horizontal Ledger VST 200 (23) with 1x Fitting Pin \varnothing 21 mm (9) on both sides respectively.
3. Secure fitting pins with cotter pins 4/1 (10). (Fig. B3.01a)
4. Repeat the procedure for all Horizontal Ledgers VST 200 (23). (Fig. B3.01b)

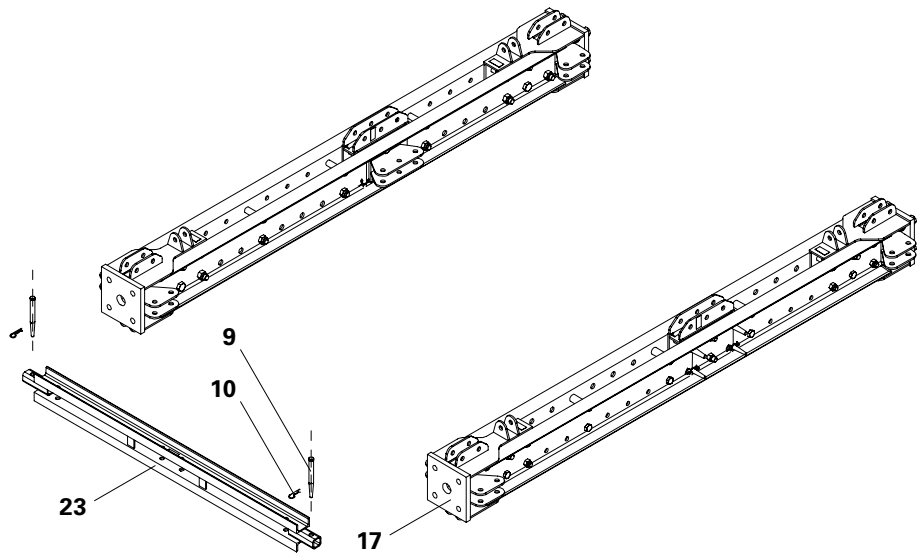

Fig. B3.01a

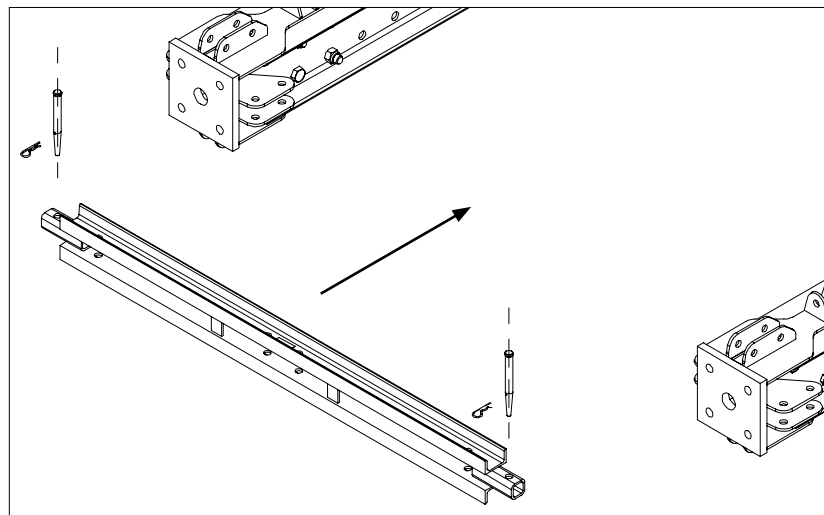

Fig. B3.01b

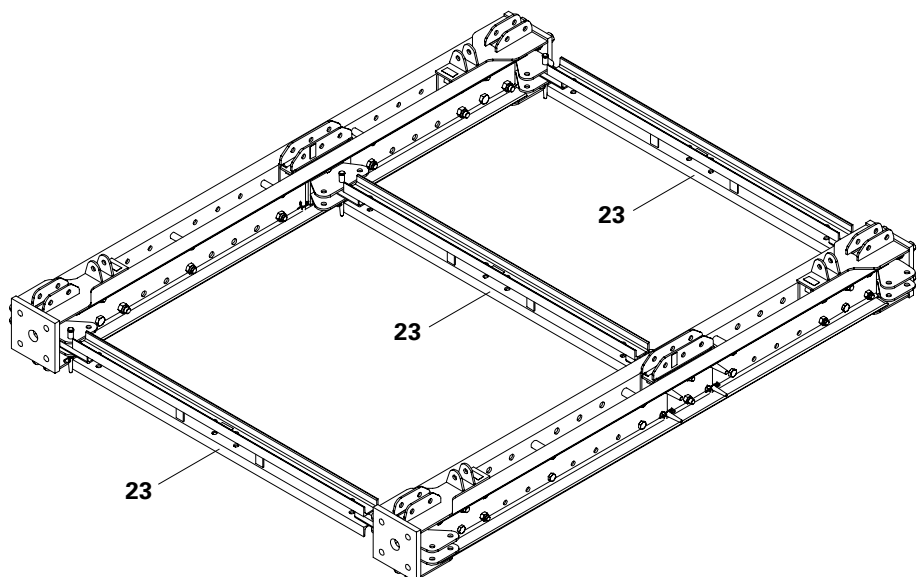

Fig. B3.01c

Diagonal Strut VST



- In order to erect the module at right angles, Diagonal Struts VST must be mounted.
- The appropriate Diagonal Struts VST can be found in Section A1 Overview.
- All diagonals can be installed in the same way.

Mounting the Diagonal Struts VST on the module

1. Connect the Diagonal Strut VST 200/150 (24a)* to the Prop Base VST 48 (17) using 1x Fitting Pin \varnothing 21 mm (9).
2. Swivel the Diagonal Strut VST 200/150 (24a)* as far as possible into the Horizontal Ledger VST 200 (23). (Fig. B3.02a)
3. Connect the second Diagonal Strut VST 200/150 (24b)* to the other Prop Base VST 48 (17) using 1x Fitting Pin \varnothing 21 mm (9).
4. Swivel second Diagonal Strut VST 200/150 (24b)* into the Horizontal Ledger VST 200 (23). (Fig. B3.02b)
5. Secure both Diagonal Struts VST 200/150 (24)* to the Horizontal Ledgers VST 200 (23) using 1x Fitting Pin \varnothing 21 mm (9) respectively. (Fig. B3.02c)
6. Repeat the procedure for all Diagonal Struts VST. (Fig. B3.02d)

* Depending on the module size, other Diagonal Struts VST are to be used.



The module is now fully assembled and can be erected or assembled to form a complete tower.



Horizontal support is connected to the Cross Connector VST not to the Bracing Connector VST. (Fig. B3.02d) (Fig. B3.02e)

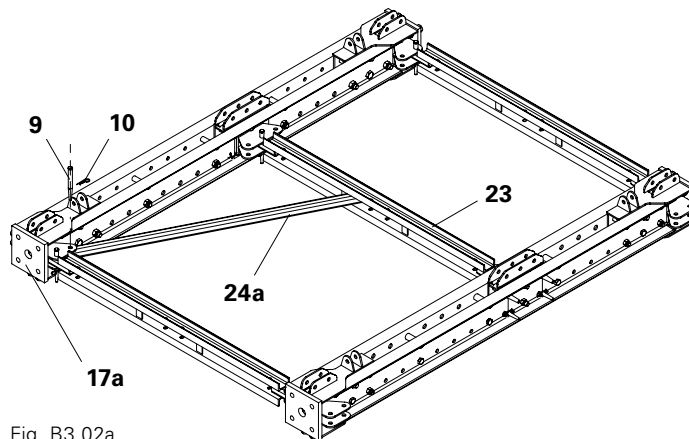

Fig. B3.02a

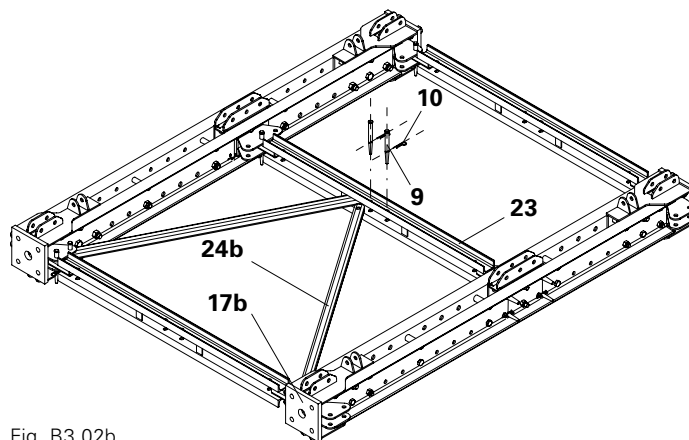

Fig. B3.02b

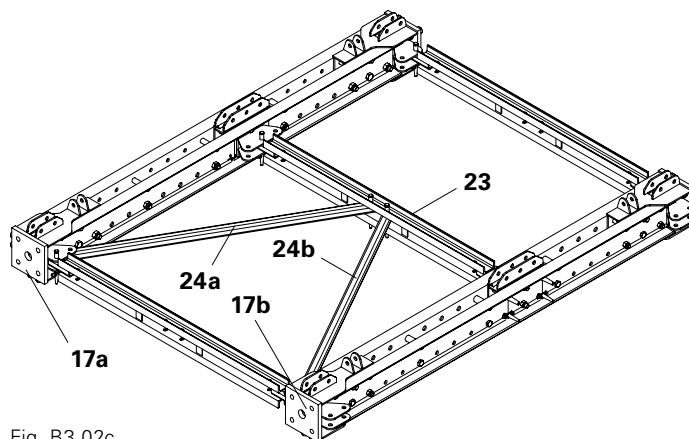

Fig. B3.02c

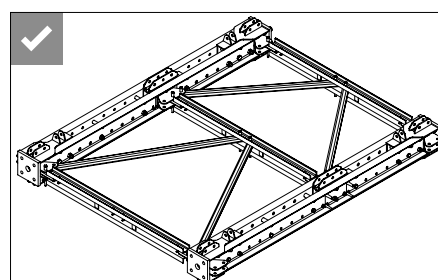

Fig. B3.02d



Abb. B3.02e

Mounting the Head Spindle Frame

Frame assembly

1. Place Head Spindles VST 100 (28) on timbers.
2. Connect the bottom Horizontal Ledger VST 200 (23a) to the first Head Spindle VST 100 (28a) using 1x Fitting Pin \varnothing 21 mm (9) and secure with Cotter Pin 4/1, galv.
3. Connect the bottom Horizontal Ledger VST 200 (23a) to the second Head Spindle VST 100 (28b) using 1x Fitting Pin \varnothing 21 mm (9) and secure with Cotter Pin 4/1, galv. (Fig. B4.01a)
4. Connect the top Horizontal Ledger VST 200 (23b) to the first Head Spindle VST 100 (28a) using 1x Fitting Pin \varnothing 21 mm (9) and secure with Cotter Pin 4/1, galv.
5. Connect the top Horizontal Ledger VST 200 (23b) to the second Head Spindle VST 100 (28b) using 1x Fitting Pin \varnothing 21 mm (9) and secure with Cotter Pin 4/1, galv. (Fig. B4.01b)

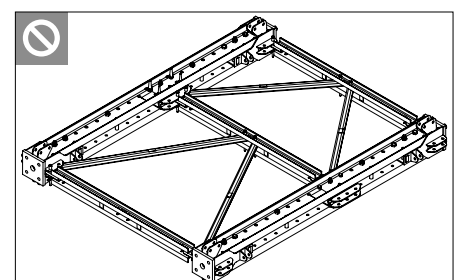
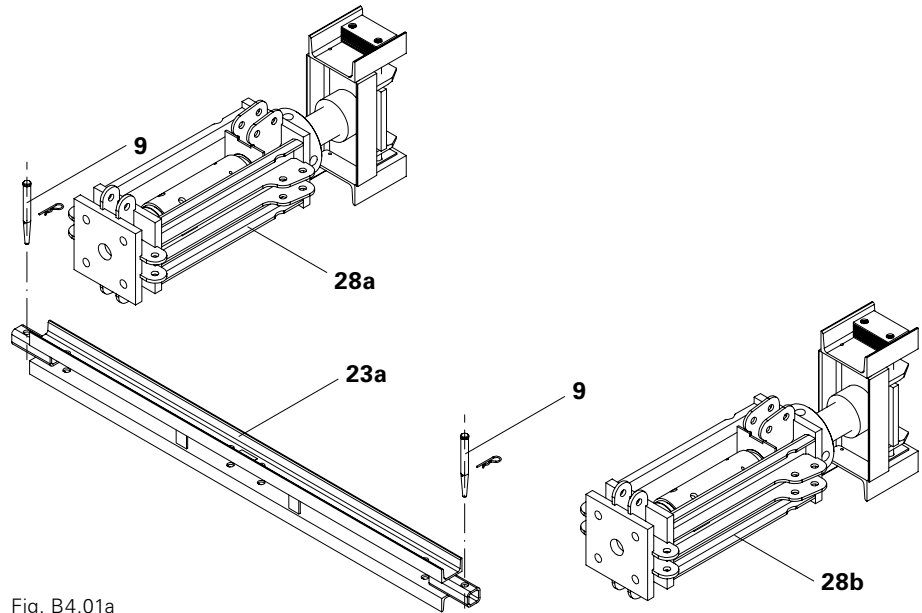

Fig. B4.01a

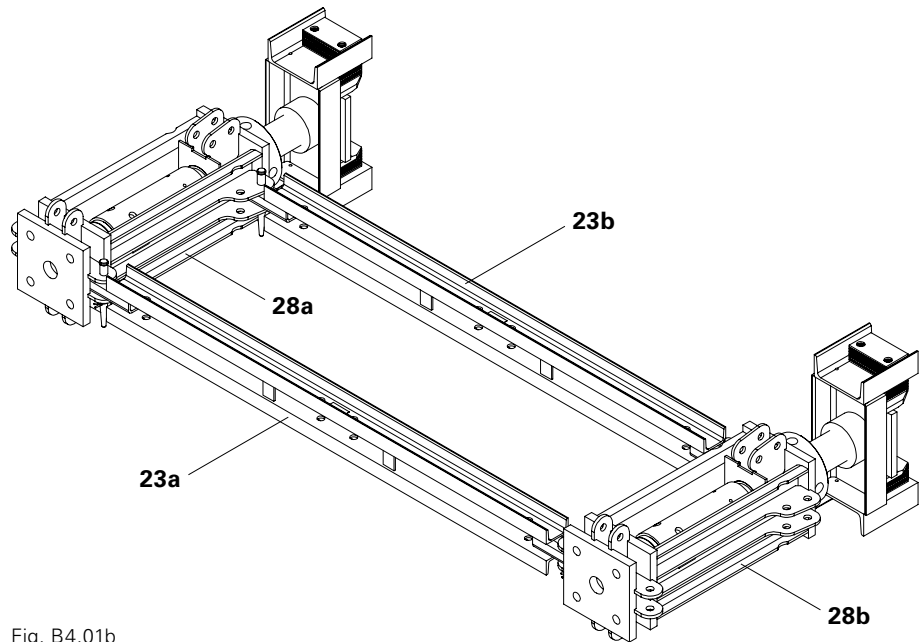

Fig. B4.01b

6. Connect the first Diagonal Strut VST 200/62.5 (27a) to the Head Spindle VST 100 (28a) using 1x Fitting Pin \varnothing 21 mm (9) and secure with Cotter Pin 4/1, galv.
7. Connect the first Diagonal Strut VST 200/62.5 (27a) to the Horizontal Ledger VST (23a) using 1x Fitting Pin \varnothing 21 mm (9) and secure with Cotter Pin 4/1, galv.
8. Connect the second Diagonal Strut VST 200/62.5 (27b) to the Head Spindle VST 100 (28b) using 1x Fitting Pin \varnothing 21 mm (9) and secure with Cotter Pin 4/1, galv.
9. Connect the second Diagonal Strut VST 200/62.5 (27b) to the Horizontal Ledger VST (23a) using 1x Fitting Pin \varnothing 21 mm (9) and secure with Cotter Pin 4/1, galv. (Fig. B4.01c)

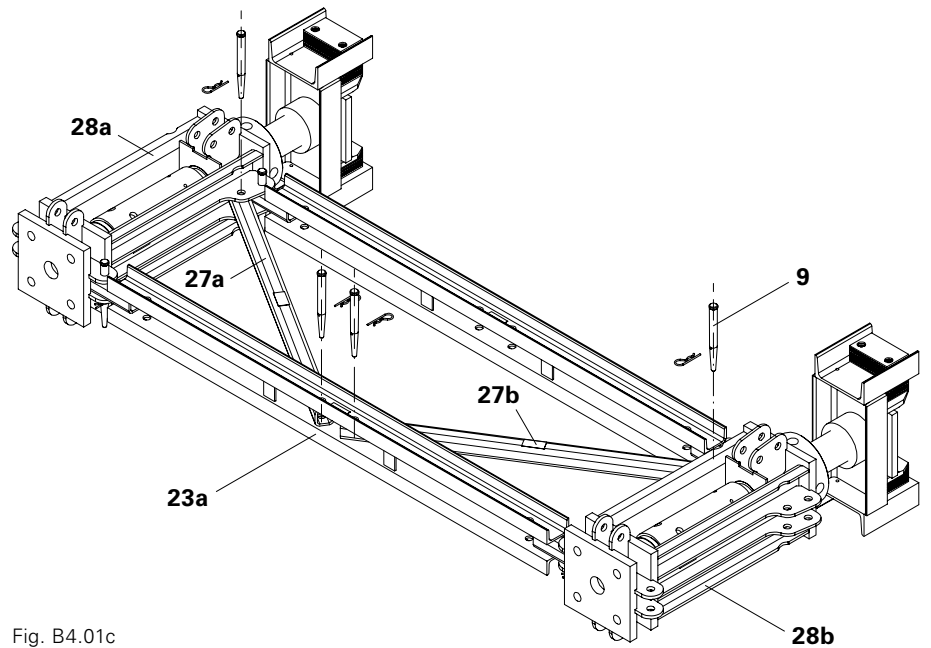

Fig. B4.01c

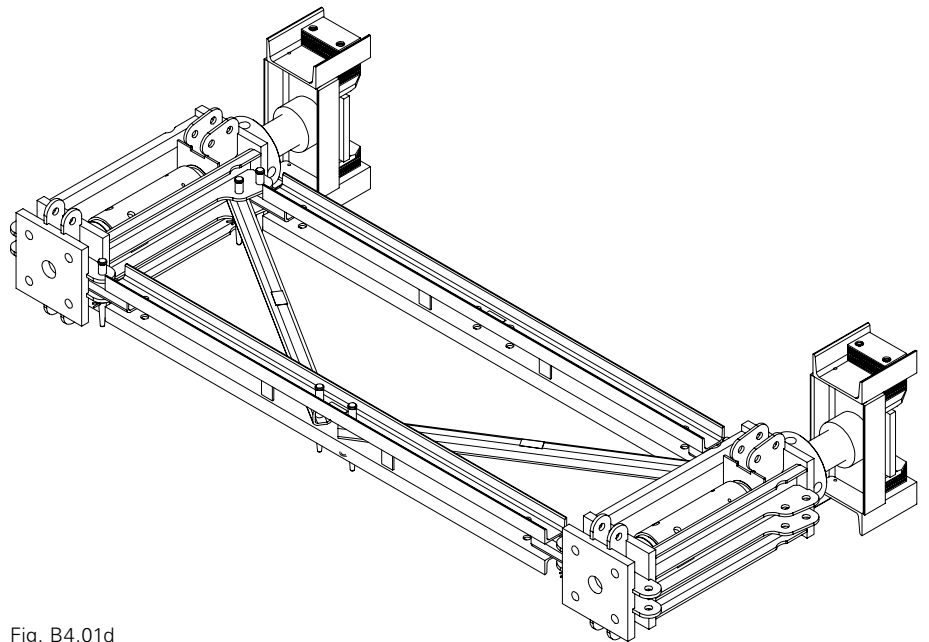

Fig. B4.01d

Adjusting the spacer plates of the Head Spindle VST 100



- The Head Spindle VST 100 (28) is adjustable for cross beam widths from 20 cm to 32 cm.
- For the centric position of the cross beam, the spacer plates are uniformly positioned on the two inner sides of the fork head.
- Follow Instructions for Use for the Hydraulic Head Spindle Device VST.

Adjusting the spacer plates

1. Loosen the four bolts of the fork head (28.1) by turning them counter-clockwise, and then remove.
 2. Remove spacer plates and adjust centering jaws by moving to width x of the cross beam.
 3. Fill the space between the centering jaws and fork head with the same number of spacer plates.
 4. Position remaining spacer plates (same number respectively) on the two outer sides of the fork head. Secure spacer plates using four bolts.
- The cross beam can now be positioned centrally on the Head Spindle VST 100.

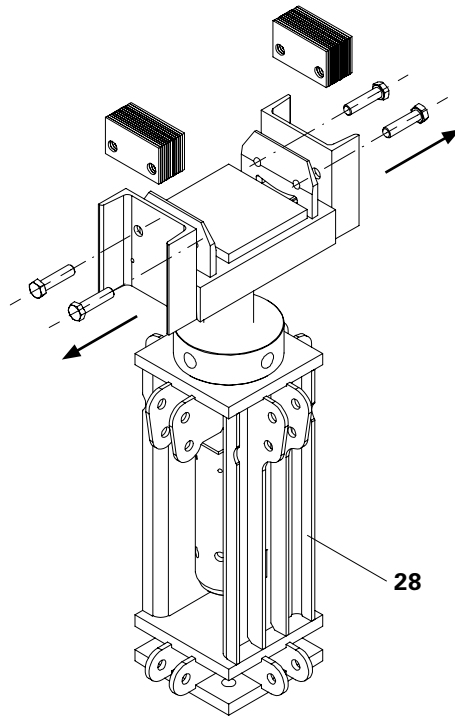

Fig. B4.02a

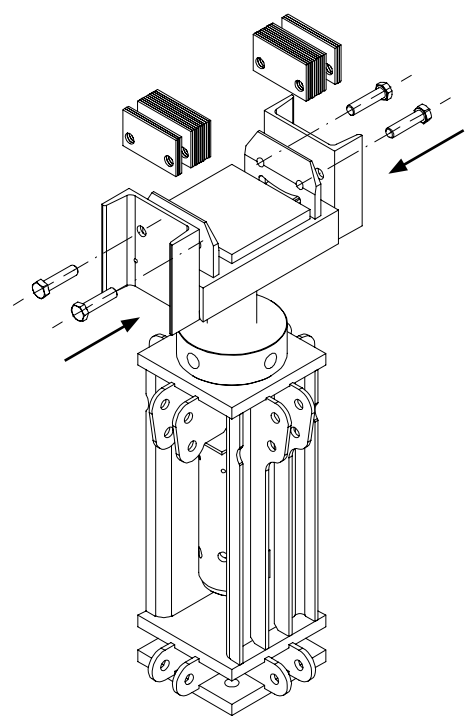

Fig. B4.02b

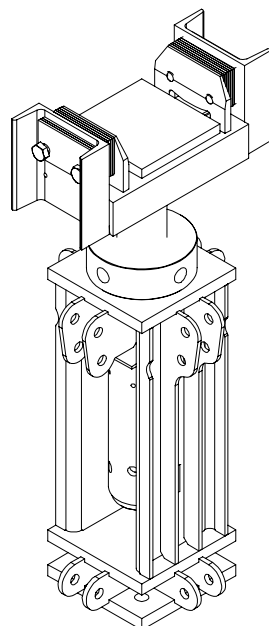

Fig. B4.02c

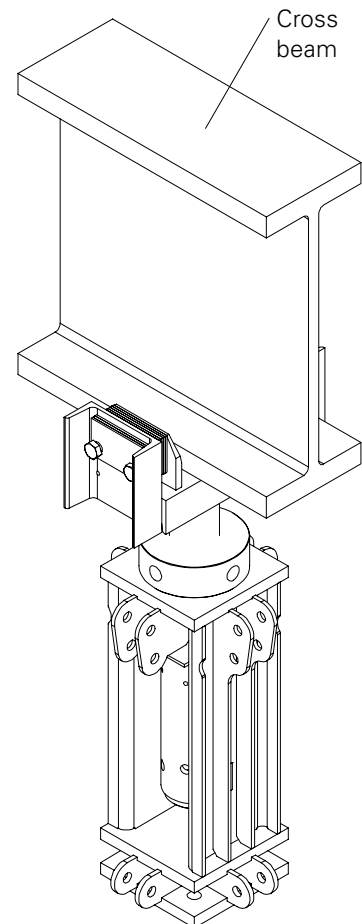

Fig. B4.02d

Tower assembly with VST components



- Persons are not allowed to remain under suspended loads.
- Temporary situations, e.g. with timbers, must be secured.



- For modules with a length of 5 m and more, a third Horizontal Ledger VST 200 (23) must be installed in order to prevent any deflection.
- For load-bearing capacities, see Section F2.

Preparation of the assembly

1. Attach the crane to the spacers.
2. On each side, connect 1x Horizontal Ledger VST 200 (23) to the Prop Bases VST 48 (17) and Prop Connectors VST 48 (21) by means of 1x Fitting Pin \varnothing 21 mm (9) respectively.
(Fig. B5.01)

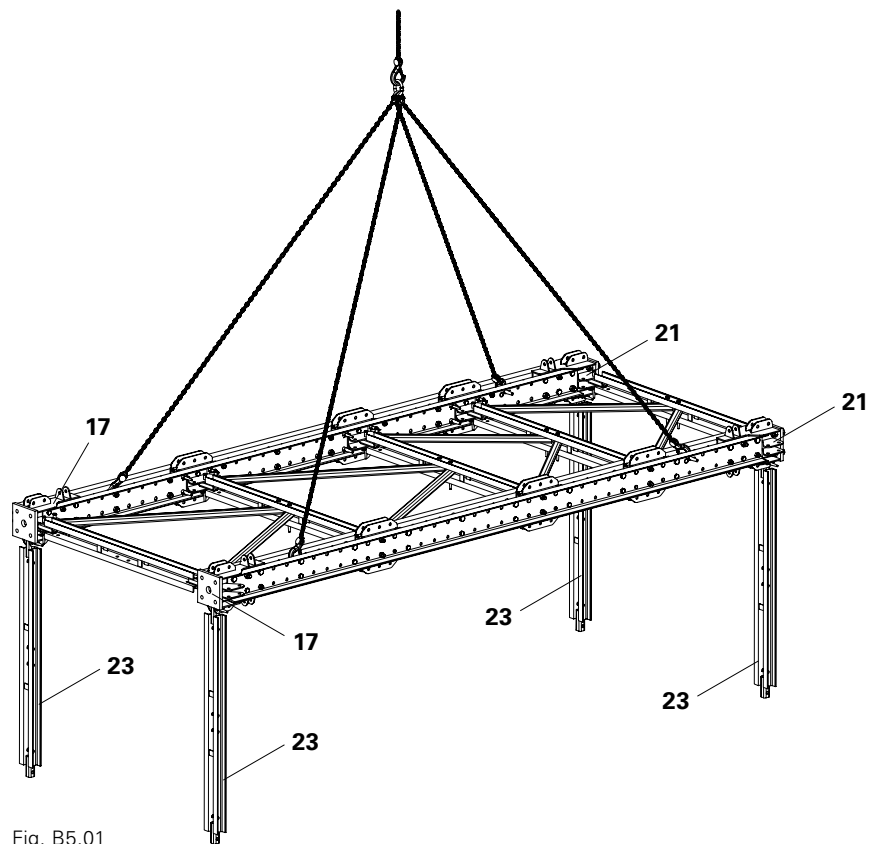
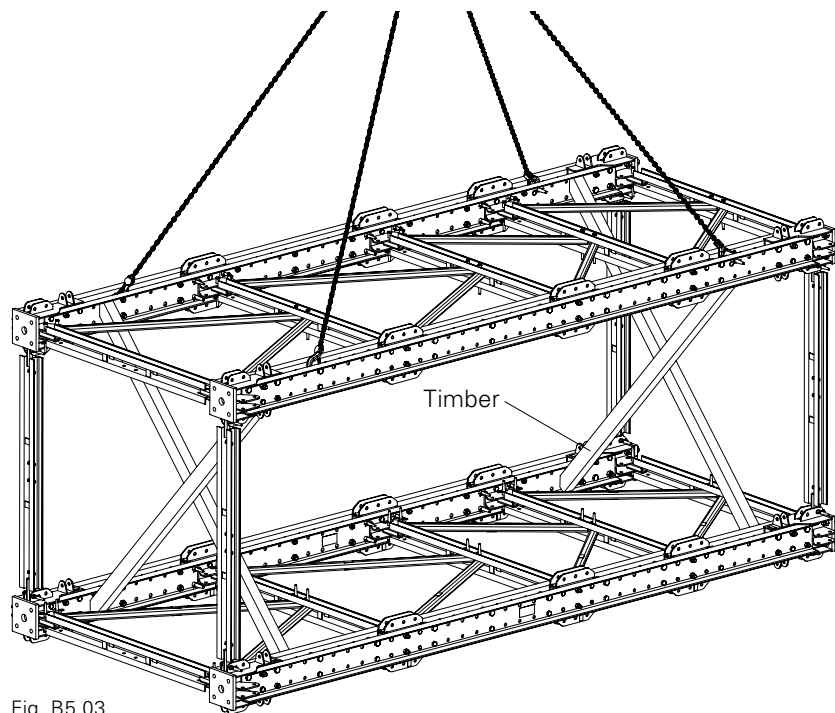
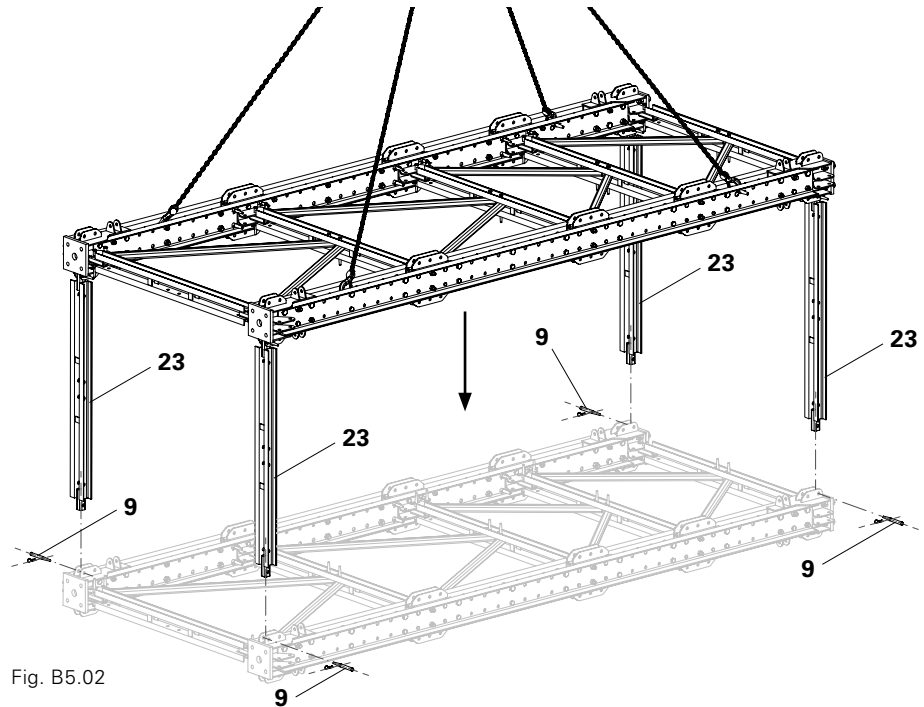

Fig. B5.01

Assembly

1. Move the suspended module with the same alignment over the second module.
2. Lower the module with the crane until the bottom Fitting Pins \varnothing 21 mm (9) can be mounted. (Fig. B5.02)
3. Connect the Horizontal Ledgers VST 200 (23) to the bottom module using 1x Fitting Pin \varnothing 21 mm (9) each. (Fig. B5.03)
4. Secure position, e.g. with timbers.





At least one Diagonal Strut VST (26) must always be installed per side before the crane lifting gear is removed.

Assembly of the Diagonal Strut VST

1. On each side, insert 1x Diagonal Strut VST (26)* into the Horizontal Ledger VST 200 (23).
2. Connect the Diagonal Strut VST (26) to the Bracing Connector VST (8) and Horizontal Ledger VST 200 (23) using 1x Fitting Pin \varnothing 21 mm (9) each. (Fig. B5.04)
3. Remove crane lifting gear from the spacers.

* Depending on the module size, other Diagonal Struts VST are to be used.

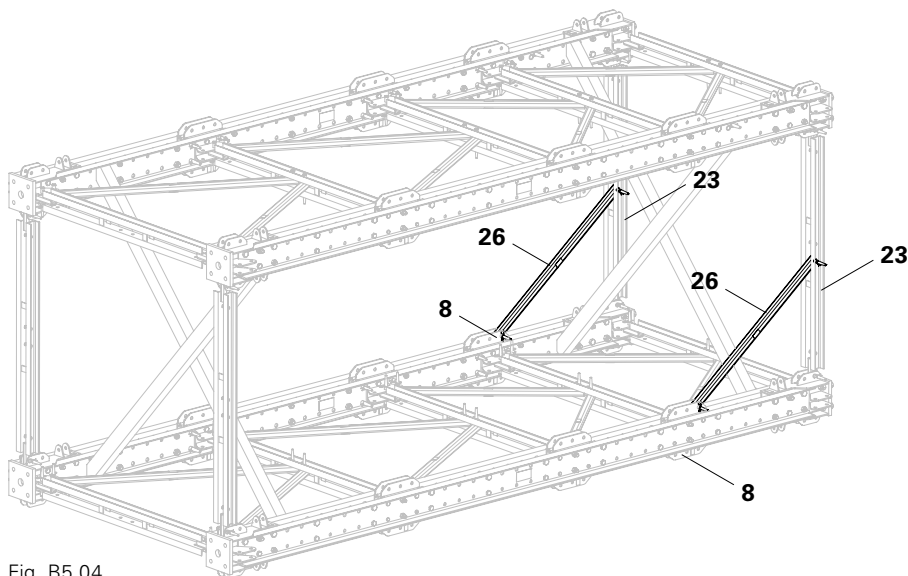

Fig. B5.04

Assembly of the Horizontal Ledgers

1. Connect the second Diagonal Strut VST (26)* to the Bracing Connector VST (8) and Horizontal Ledger VST 200 (23) using 1x Fitting Pin \varnothing 21 mm (9) each.
2. Install the required Horizontal Ledgers VST 200 (23). (Fig. B3.05) (see Section B3)

* Depending on the module size, other Diagonal Struts VST are to be used.

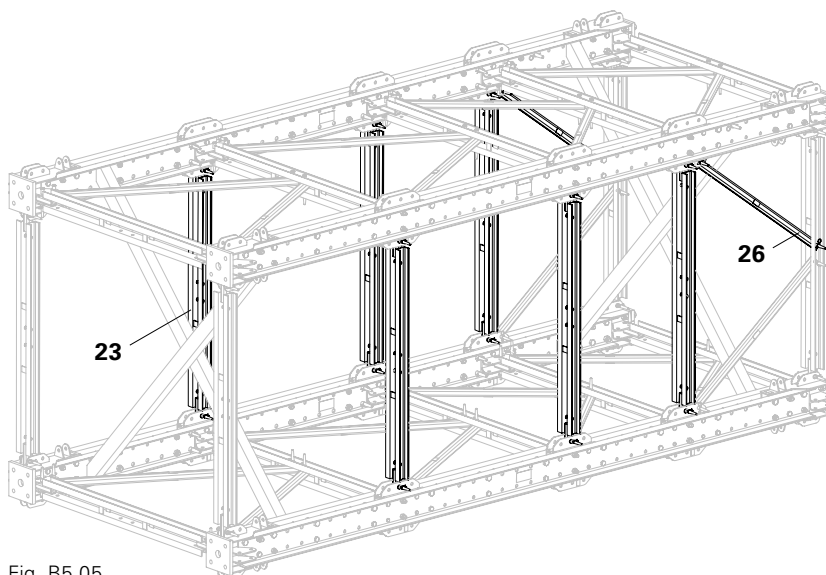

Fig. B5.05

Assembly of the Diagonal Struts

1. Install the required number of Diagonal Struts VST. (Fig. B5.06) (see Section B3)
2. Remove timbers.

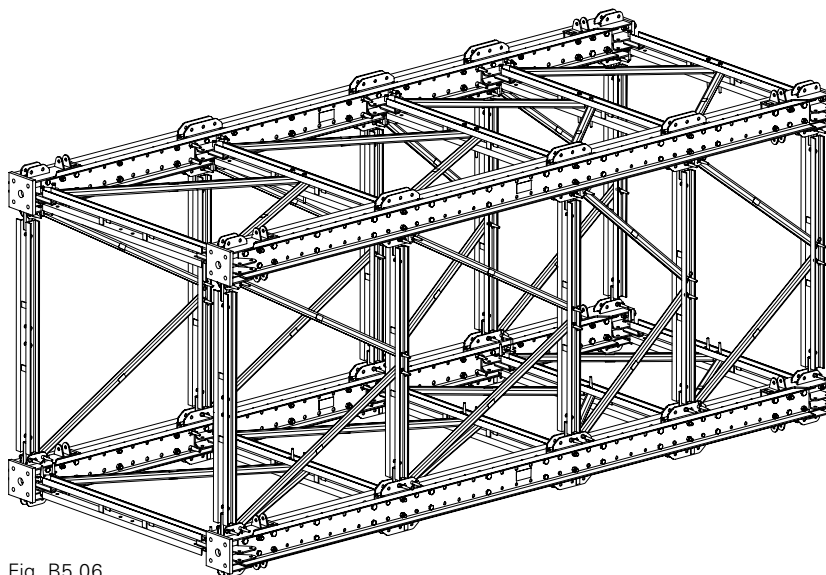

Fig. B5.06

Tower assembly with SLS Spindles



- Persons are not allowed to remain under suspended loads.
- Temporary situations, e.g. with timbers, must be secured.



Adjust the required length on all four spindles according to the spacing of the legs.



- For modules with lengths of 5 m and more, a third Heavy-Duty Spindle SLS (30) must be installed in order to prevent any deflection.
- For load-bearing capacities, see Section F2.

Preparation of the assembly

1. Attach the crane lifting gear to the spacers.
2. Connect 2x Heavy-Duty Spindles SLS (30) each to the Prop Bases VST 48 (17) and Prop Connectors VST 48 (21) by means of 1x Fitting Pin \varnothing 21 mm (9) each. (Fig. B5.07)

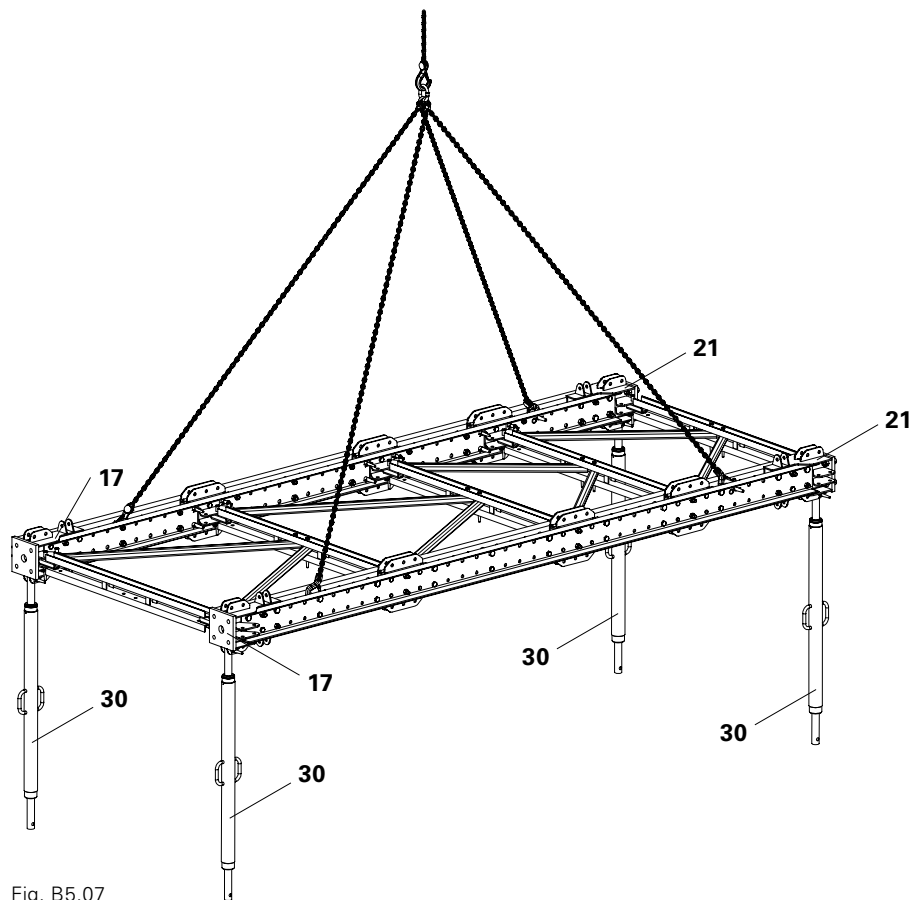
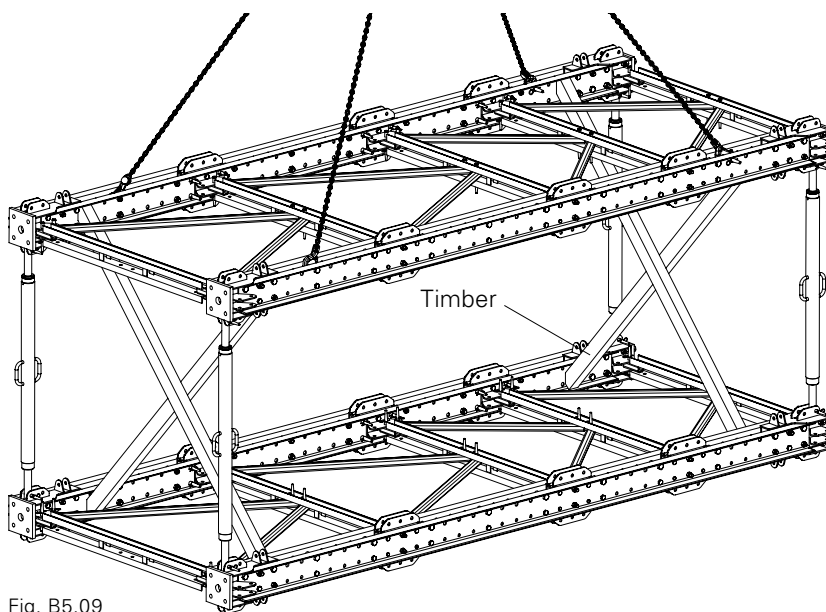
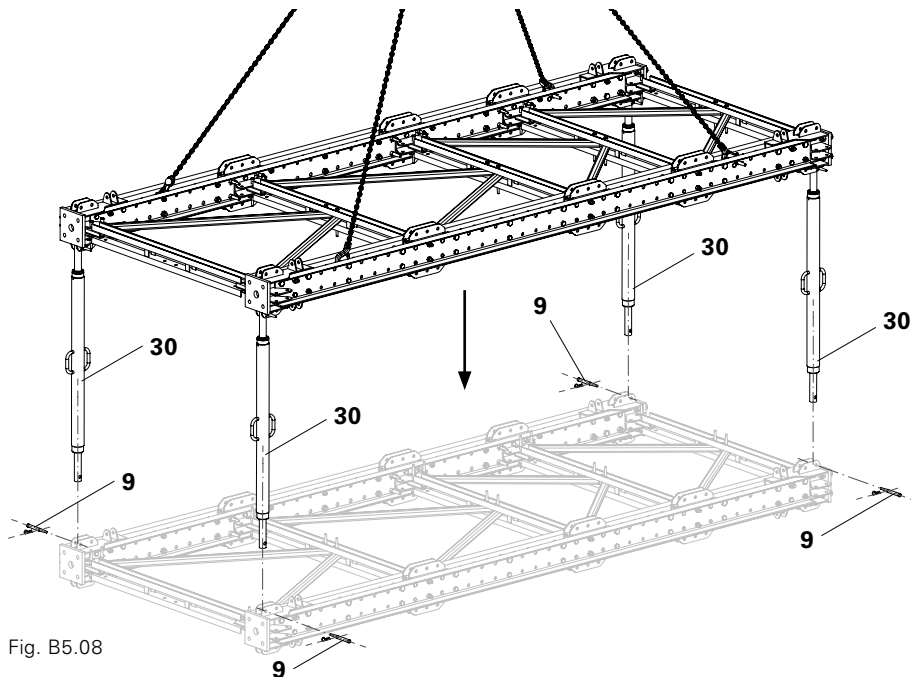

Fig. B5.07

Assembly

1. Move the suspended module with the same alignment over the second module.
2. Lower the module with the crane until the bottom Fitting Pins \varnothing 21 mm (9) can be mounted. (Fig. B5.08)
3. Connect the Heavy-Duty Spindles SLS (30) to the bottom module using 1x Fitting Pin \varnothing 21 mm (9) each.
4. Secure position, e.g. with timbers. (Fig. B5.09)





At least one Heavy-Duty Spindle SLS must always be installed per side as a diagonal before the crane lifting gear is removed.

Assembly of the supporting Heavy-Duty Spindles SLS

1. Insert the appropriate Heavy-Duty Spindle SLS (30) into the connection of the Prop Base VST 48 (17).
2. Connect the Heavy-Duty Spindle SLS (30) to the Bracing Connector VST (8) and Prop Base VST 48 (17) by means of 1x Fitting Pin \varnothing 21 mm (9) each. (Fig. B5.10)
3. Remove crane lifting gear from the spacers.

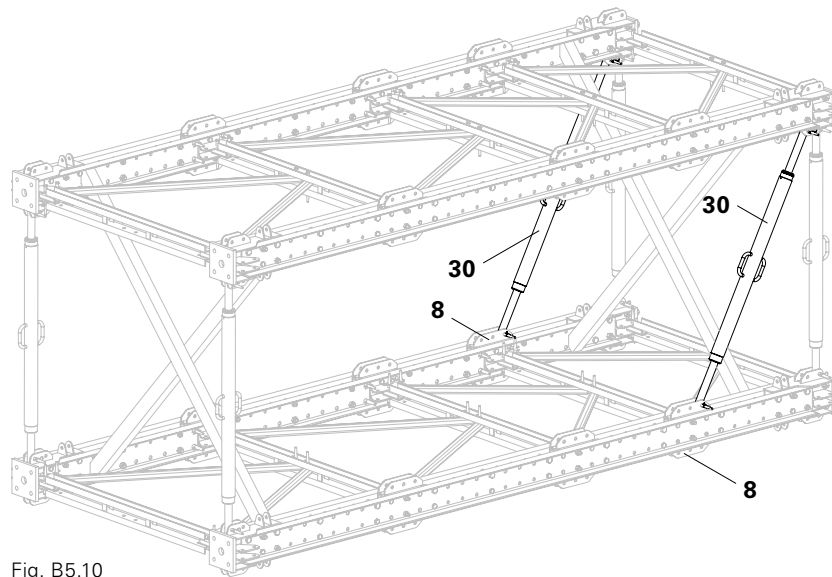

Fig. B5.10

Assembly of the Heavy-Duty Spindles SLS

1. Install the required number of Heavy-Duty Spindles SLS (30) using Fitting Pins \varnothing 21 mm (9). (Fig. B5.11)
2. Remove timbers.

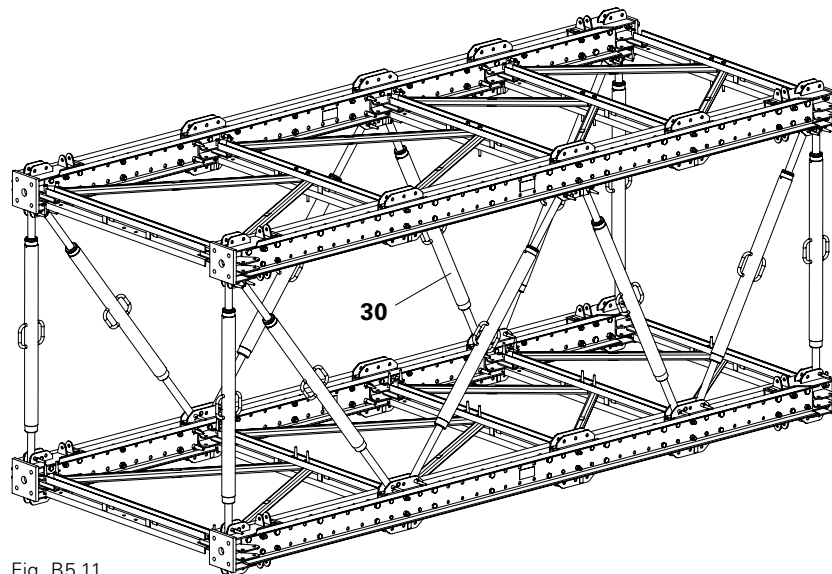

Fig. B5.11



Prior to assembly, stability of the module must be guaranteed.

Mounting the Connector UP-VST

1. Insert 1x Connector UP-VST (38a) from below into the Horizontal Ledger VST 200 (23a) as a horizontal bearing on the left and right.
2. Secure Connectors UP-VST (38) with Fitting Pins \varnothing 21 mm (9) or PERI Wedge K (40). (Fig. B6.01a + B6.01b)
3. Insert 1x Connector UP-VST (38b) laterally into the Horizontal Ledger VST 200 (23b) as a vertical bearing on the left and right.
4. Secure Connectors UP-VST (38) with Fitting Pins \varnothing 21 mm (9) or PERI Wedge K (40). (Fig. B6.01a + B6.01b)

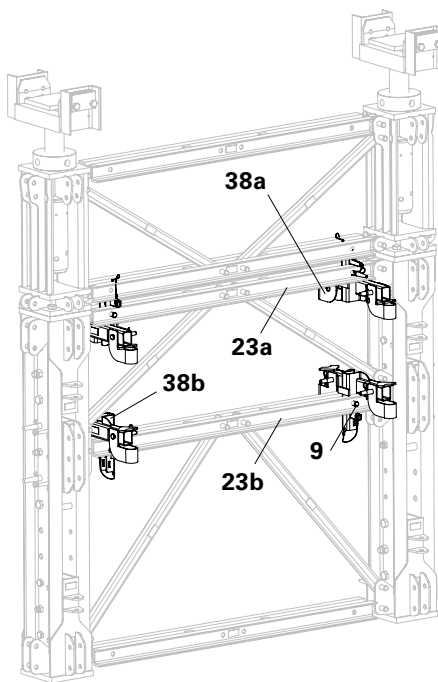

Fig. B6.01a

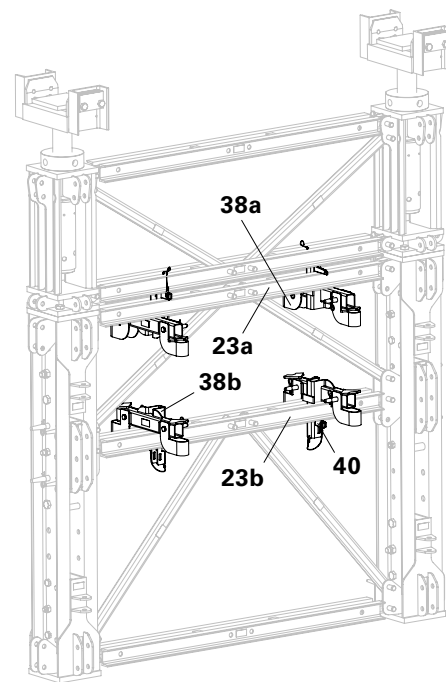

Fig. B6.01b

Installation of the Standard UVR

1. Place Standard UVR 300 (46.1) (for VST 175: Standard UVR 150 (46.2)) with the rosette on the Connector UP-VST (38).
2. Mount retaining lug (38.1) to the bottom Connector UP-VST (38) using Bolts \varnothing 20 x 140 (39) and secure with Cotter Pins 4/1, galv.
3. Mount retaining lug (38.1) to the top Connector UP-VST (38) using Bolts \varnothing 20 x 140 (39) and secure with Cotter Pins 4/1, galv.



Here, the rosette has to rest on the Connector UP-VST (38) in order to safely transfer the forces. (Fig. B6.02a)

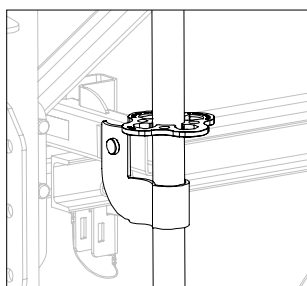

Fig. B6.02a

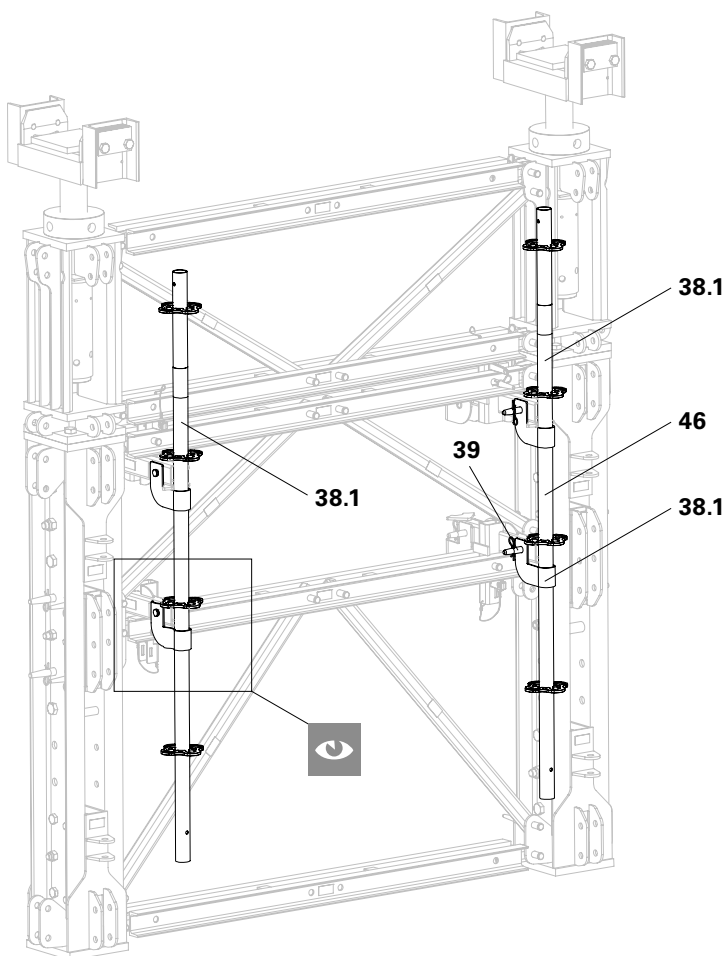

Fig. B6.02

VST Heavy-Duty Shoring Tower

Instructions for Assembly and Use – Standard Configuration

Installation of the Ledger UH 150

1. Install the required Ledgers UH 150 (47) between the Standards UVR (46).

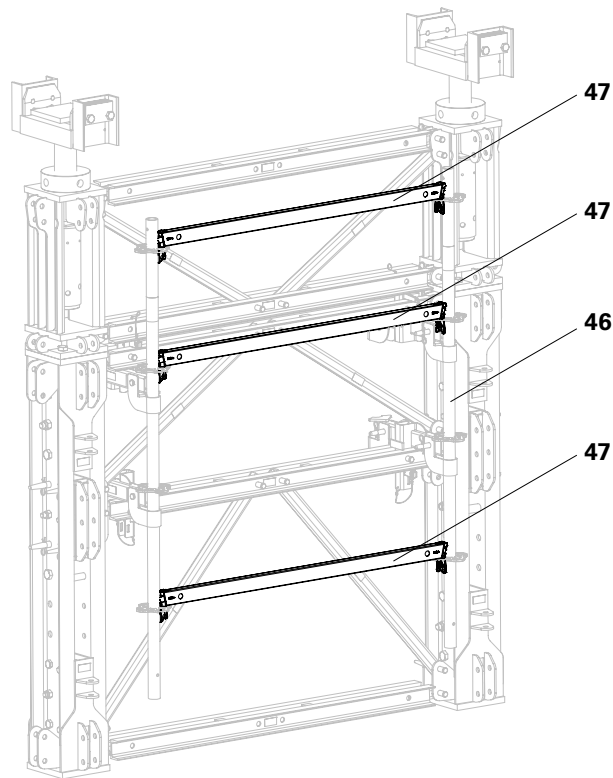

Fig. B6.03



- Project-specific planning is always required for the working platforms.
- Follow the Instructions for Assembly and Use for the PERI UP Rosett 72.

Installing the platform

1. Installation of the required brackets and standard components of the PERI UP system.

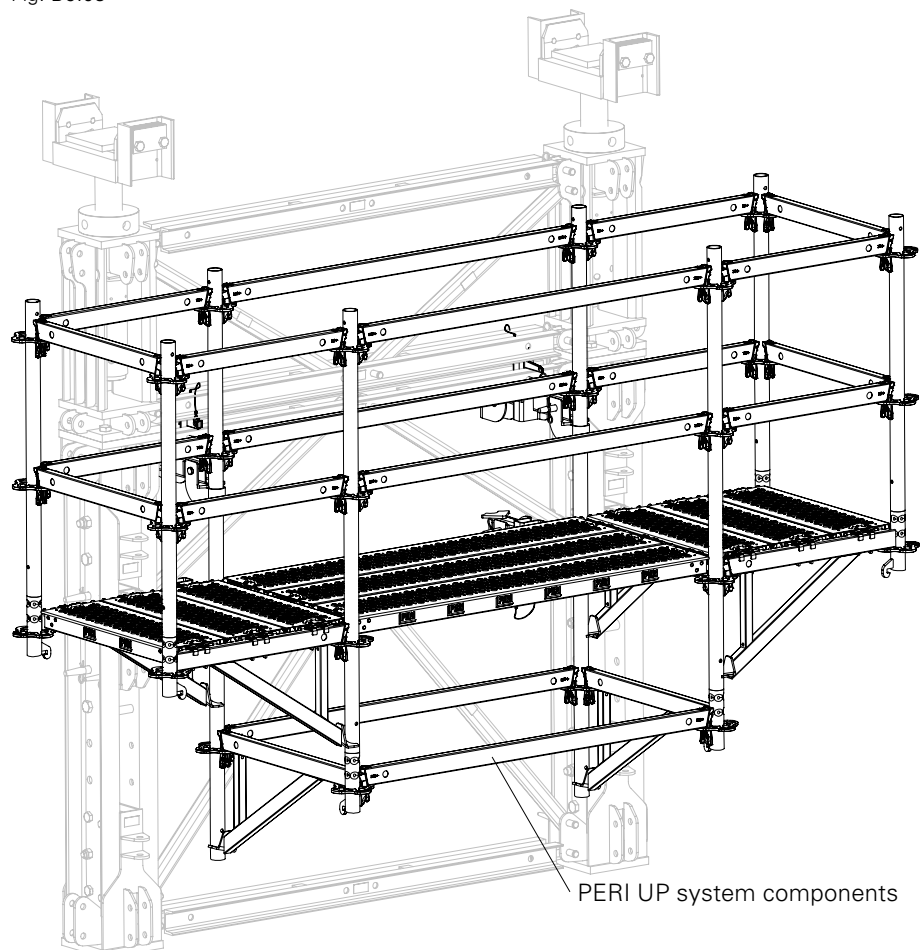

Fig. B6.04



- Observe the information on attaching lifting gear in Section F4.
- Use textile lifting gear with sufficient load-bearing capacity.
- When erecting the tower, ensure that no persons remain in the area of risk.
- Persons are not allowed to remain under suspended loads.
- Only one tower segment may be moved at any one time.



- For the installation, a crane or other lifting device as well as a level assembly surface is required.
- Intermediate states are to be correctly secured by means of temporary supports to prevent any tipping over.
- Provide sufficient space for intermediate storage.
- Additional assembly plans are required.
- For assembly, the use of lifting platforms or mobile scaffolds is recommended.
- In individual cases, the use of personal protective equipment may be necessary.

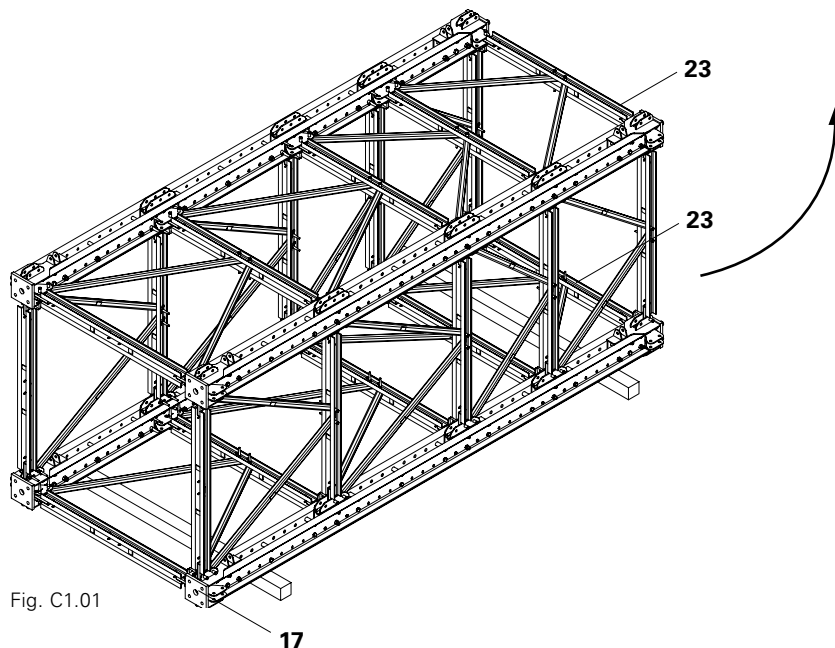

Fig. C1.01

Attaching to the crane

1. Attach lifting gear to the tower (see Section F4).
2. Use the crane to tilt the tower over the Prop Base VST 48 (17).

Erecting the tower

1. Slowly erect the tower until it is vertically positioned.



Use a rope to guide the tower.

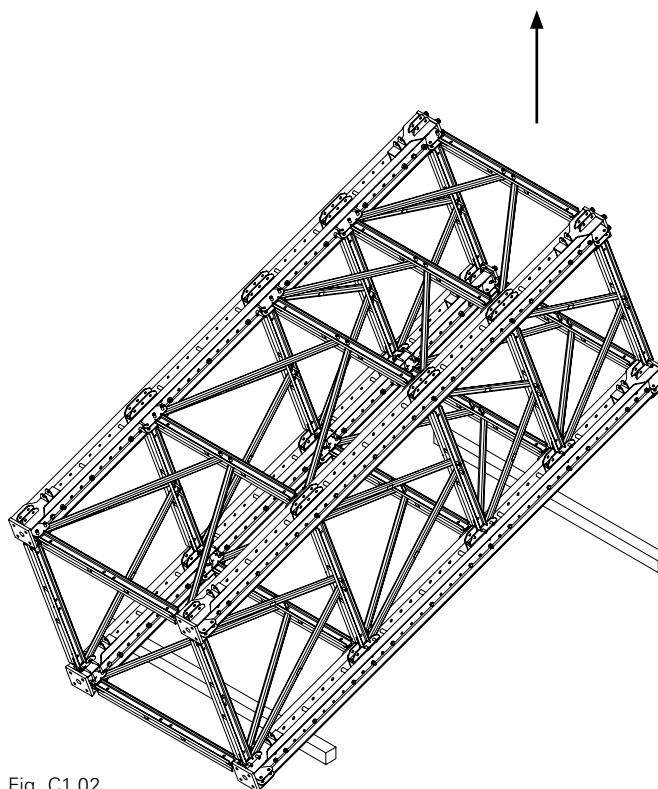

Fig. C1.02

Moving the tower



- Check that the foundation is level and sufficiently load-bearing before lowering the tower.
- Any unevenness must be corrected by using cement grouting which has the same quality as the concrete. (see Section C3)

1. Lift the tower and set down on its designated position. (Fig. C1.02a)
2. Place the construction on the foundation and install anchors. (see Section C3)
3. Release tower from crane lifting gear.

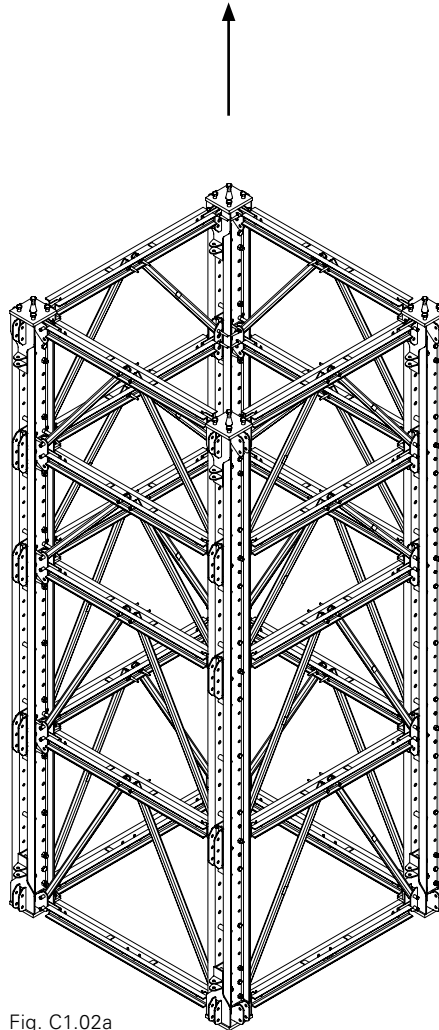

Fig. C1.02a

Positioning on an existing tower



Crushing hazard, keep a safe distance.



The towers centre themselves through the spigots of the Prop Connectors VST 48 (21).

1. Place tower on existing tower. (Fig. C1.02b)
2. Connect the supporting elements on all legs using four bolts each of the individual Prop Connectors VST 48 (21).
3. Release tower from the crane lifting gear.

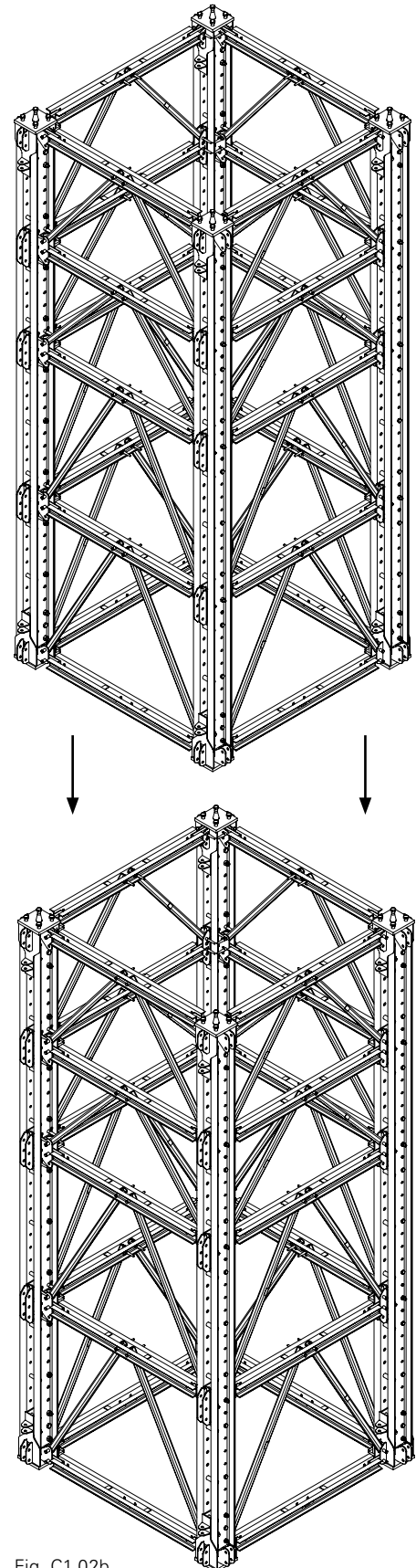

Fig. C1.02b



- Observe the information on attaching lifting gear in Section F3.
- Use textile lifting gear with sufficient load-bearing capacity.
- When erecting the module, ensure that no persons remain in the area of risk.
- Persons are not allowed to remain under suspended loads.
- Only one module may be moved at any one time.

Attaching to the crane

1. Attach lifting gear to the module (see Section F3).
2. Use the crane to tilt the module over the Prop Base VST 48 (17).



Use a rope to guide the tower.

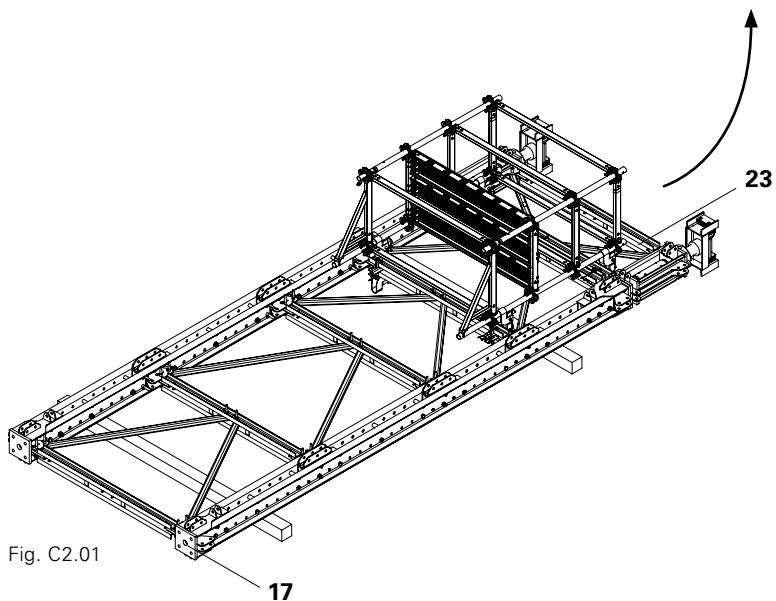

Fig. C2.01

Erecting the tower

1. Slowly erect the module until it is vertically positioned.
2. Lift the module and set it down on its designated position.

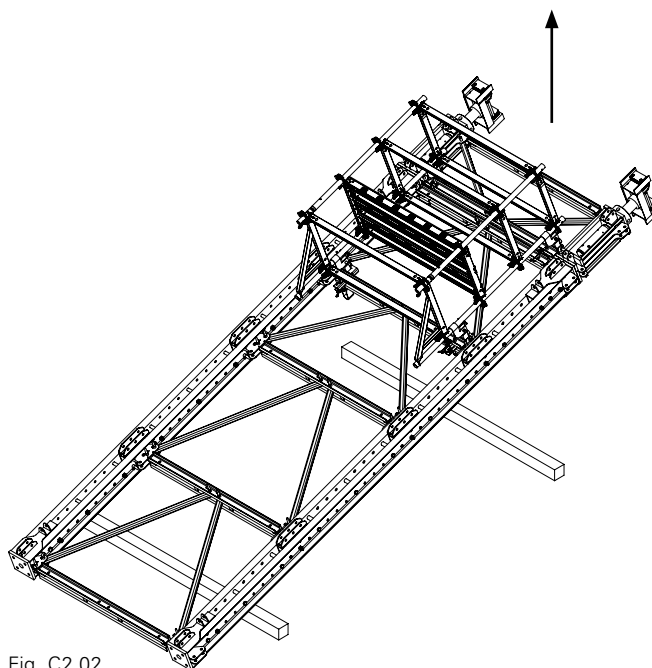

Fig. C2.02

Installation in front of abutment / piers



- Only access a working platform when the module has been anchored and secured.
- Assembly work must be carried out from a safe position.



- Anchor the module to the foundation. (see Section C3)
- In order to keep the module in a horizontal position, the anchor holes on the abutment/pier can be used, e.g. with Steel Waler SRU U120 (48) and Heavy-Duty Spindle SLS (30). (Fig. C2.03)
- Observe the project-specific planning of the access points.

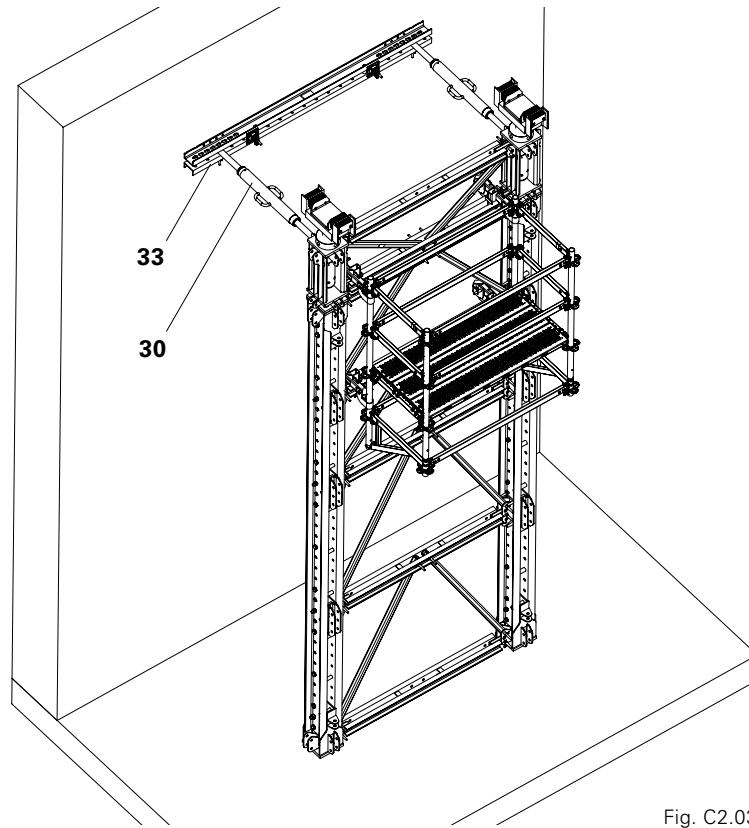

Fig. C2.03

Securing on the foundation



- Anchor the module to the foundation. (see Section C3)
- Secure the module to the foundation using a Heavy-Duty Spindle SLS (30).
- If module anchorage for the foundation is available, one Heavy-Duty Spindle SLS (30a) in the bottom third is sufficient.
- If no module anchorage for the foundation is available, the Heavy-Duty Spindle SLS (30b) must be mounted on the Bracing Connector VST (8) in the top third.

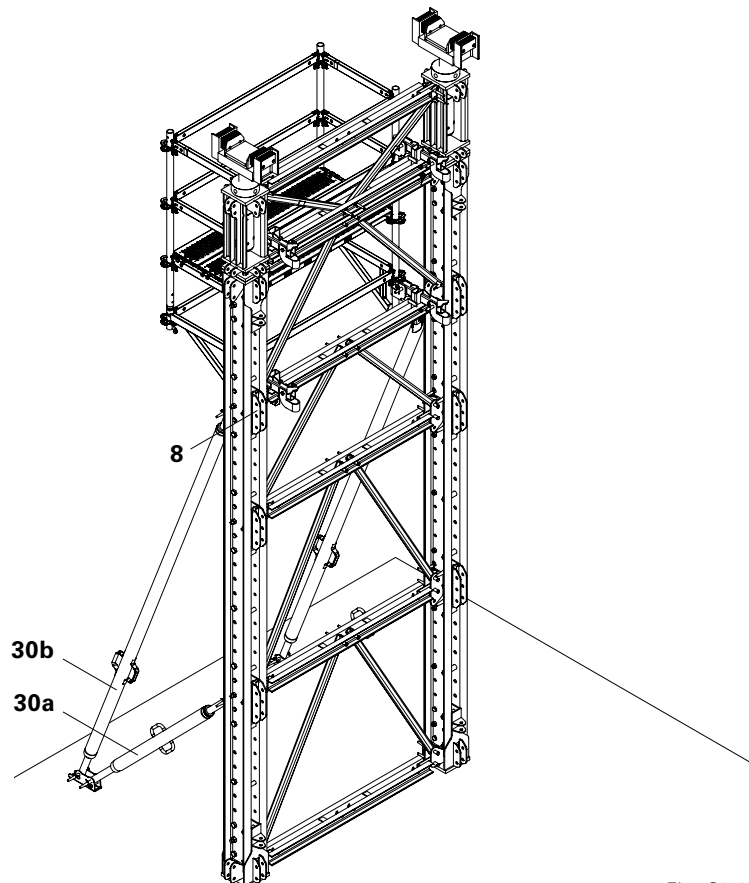

Fig. C2.04



Observe the project-specific planning.

Installation of a second module

1. Lift the second module and set it down on its designated position (see Section F3).
2. If required, anchor the module to the foundation.



Use a rope to guide the tower.

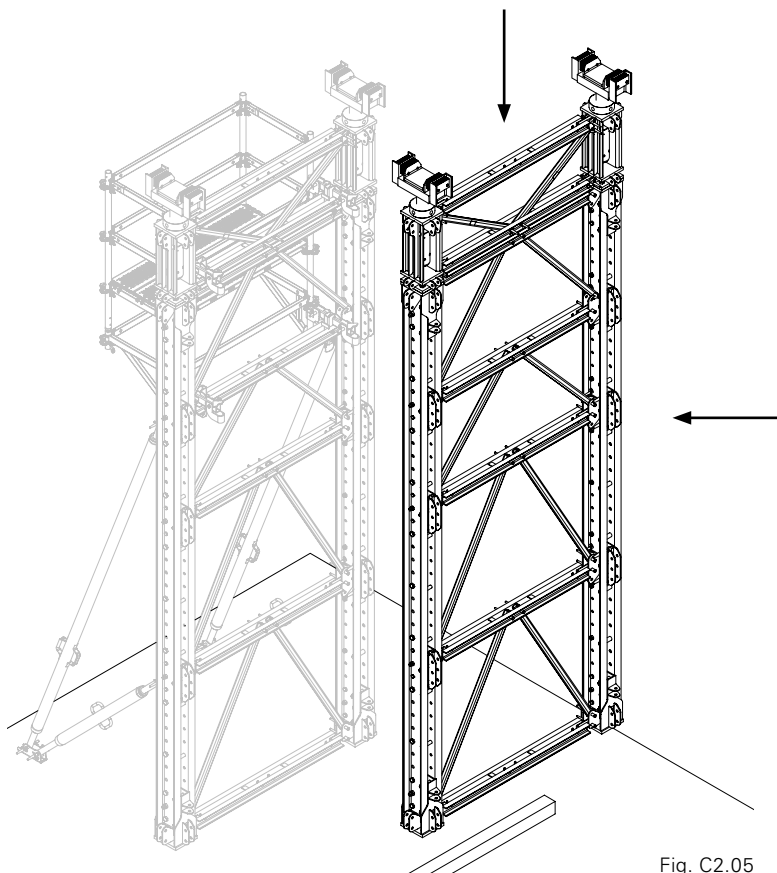

Fig. C2.05



Assembly work must be carried out from a safe position.

Securing of the second module

1. Mount the horizontal Heavy-Duty Spindles SLS (30a) on the Prop Connector VST 48 (21) and adjust the spacing between the modules.
2. Install one Heavy-Duty Spindle SLS (30b) as a diagonal strut for bracing the tower.
3. Detach crane lifting gear.

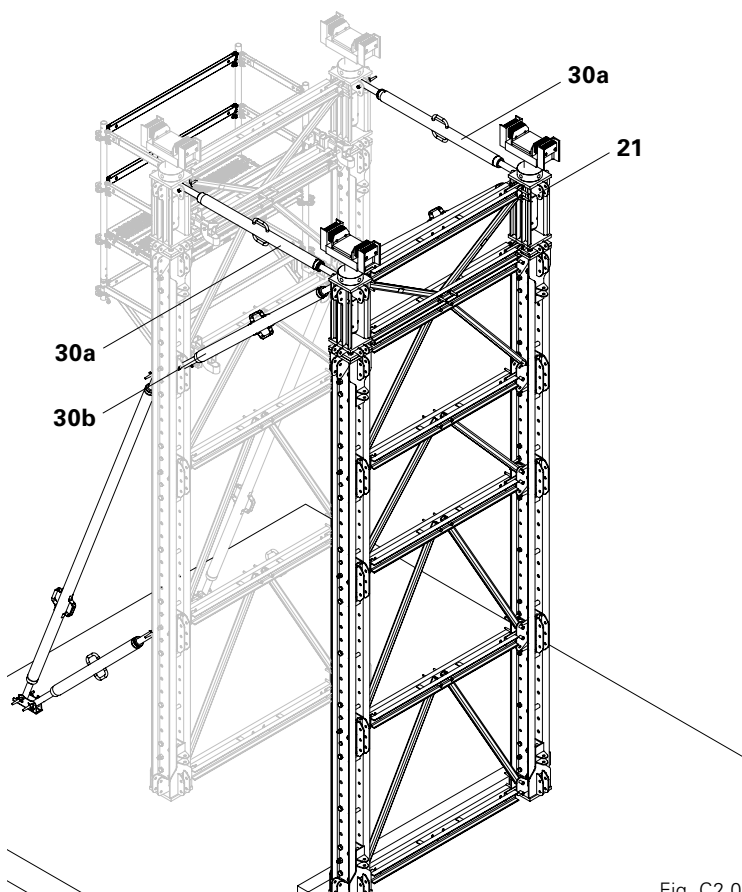

Fig. C2.06



Assembly work must be carried out from a safe position.

Bracing the tower

1. Installation of the statically required Heavy-Duty Spindles SL (30) for bracing the tower.

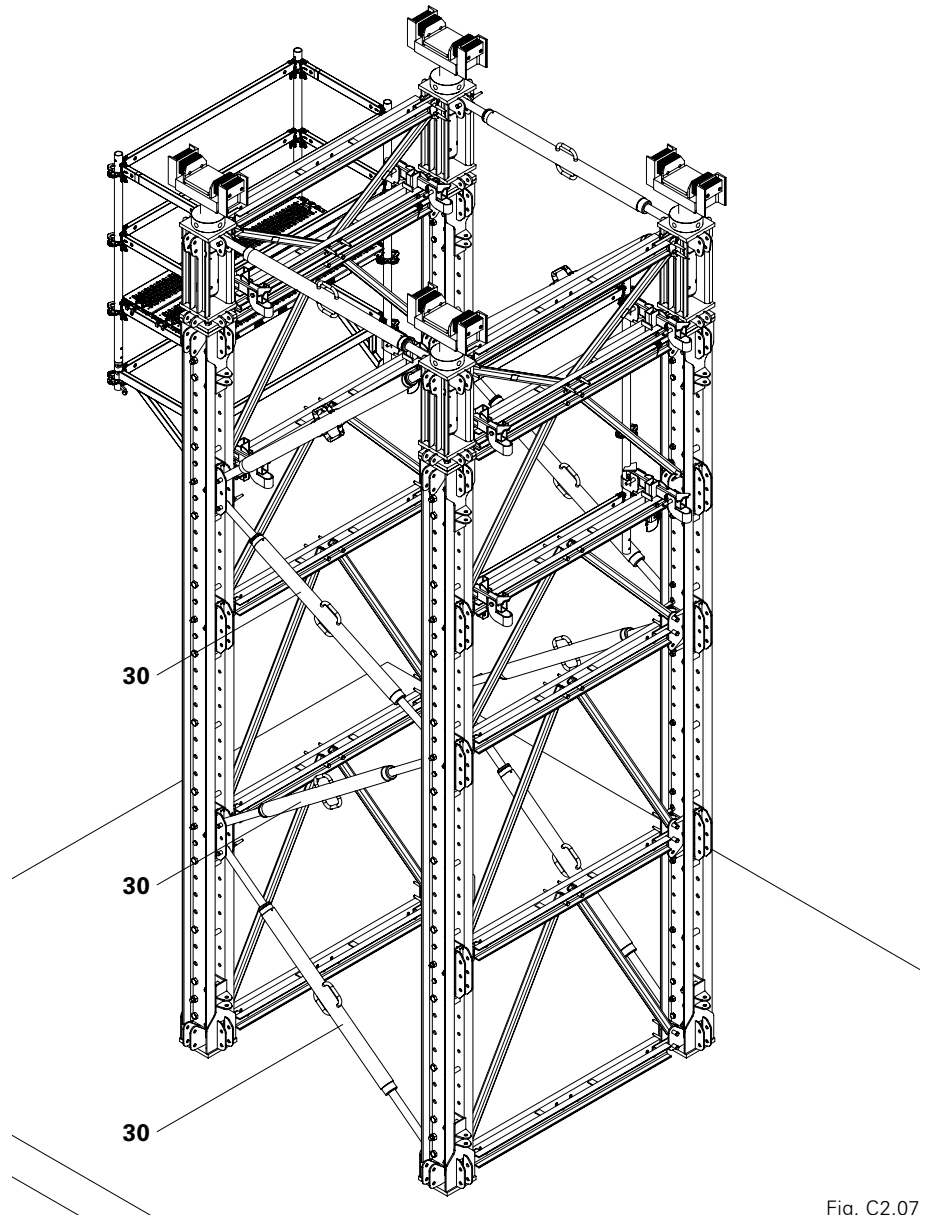

Fig. C2.07



- Components must have sufficient load-bearing capacity.
- Follow the manufacturer's instructions.



- In order to achieve a full-surface contact between the foundation and the Prop Base VST 48 (17), the gap must be completely filled with non-shrinkable cement grouting.
- The quality of the cement grouting must correspond to the quality of the concrete.
- Project-specific verification is required.

Version 1

- Anchoring the module with Tie Rod DW 15 (50) and Cam Nut DW 15 (51).
- The number of anchors must be statically calculated.

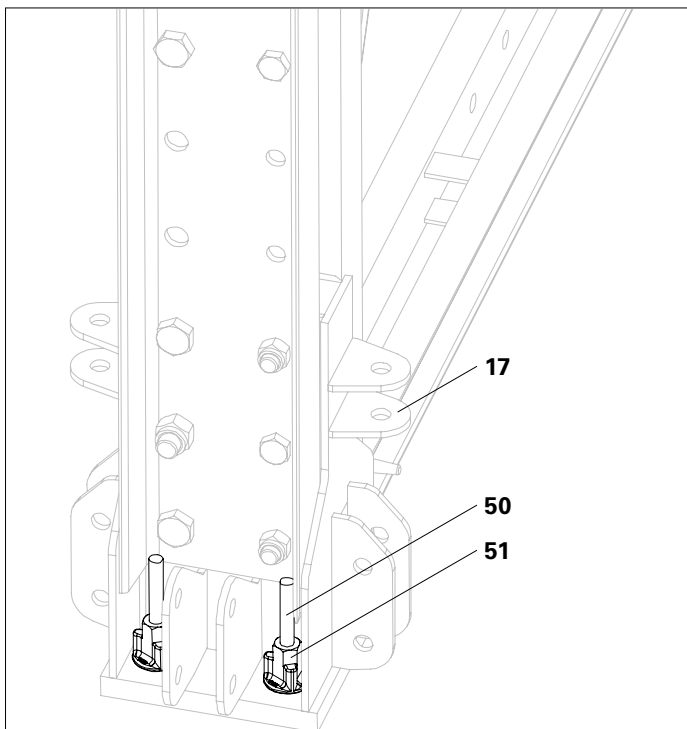

Fig. C3.01

Version 2

- Anchoring the module with Tie Rod DW 26 (53), Counterplate DW 26 (54) and Hex. Nut DW 26 SW 46/80, weldable (55).

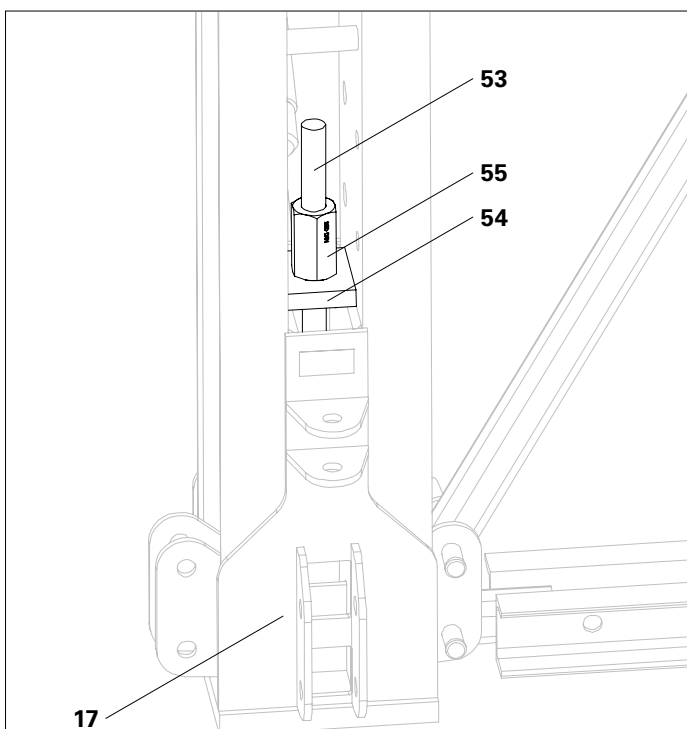

Fig. C3.03



- Follow Instructions for Use for the Hydraulic Head Spindle Device VST.
- Lowering is carried out from a safe working position.
- Project-specific lifting and lowering plans are to be observed.
- Crushing hazard when lowering.
- The maximum spindling length must not exceed 1138 mm measured from the base plate of the head spindle to the top edge of the bearing plate.

Manual adjustment



For all procedures, follow Instructions for Use for the Hydraulic Head Spindle Device VST.



One complete turn of the spindle nut results in a height adjustment of 12 mm.

1. Insert the Mounting Shaft VST (29) into the spindle nut (28.1). (Fig. D1.01)
2. Turn the Mounting Shaft VST (29) in a clockwise direction in order to spindle out the spindle head. (Fig. D1.02)

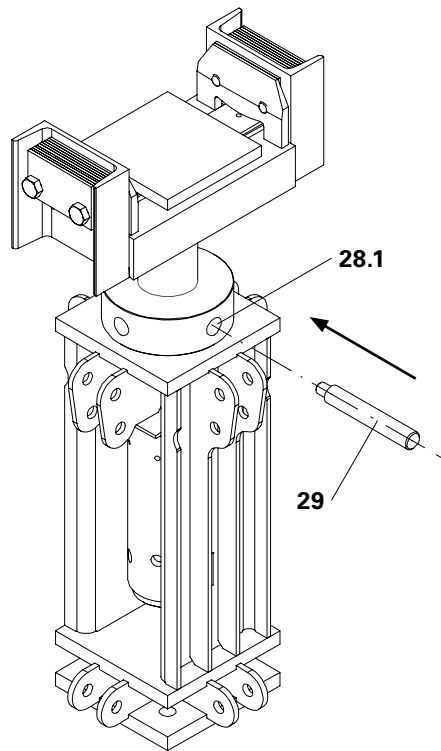

Fig. D1.01

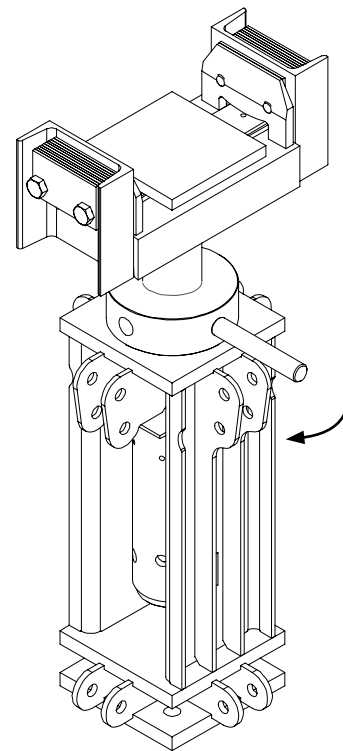

Fig. D1.02

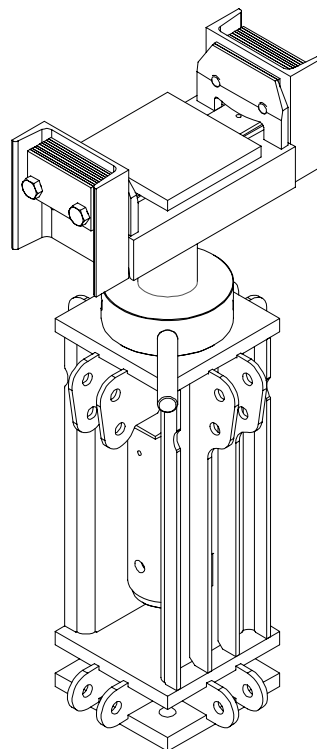

Fig. D1.03

D1 Height adjustment (± 140)

Adjustment with the hydraulic cylinder



With the hydraulic cylinder, lifts of max. 10 mm per step are possible.

Lifting

1. Insert the hydraulic cylinder (43.4) into the Head Spindle VST 100 (28).
2. Insert the Mounting Shaft VST (29) into the spindle sleeve (28.3). (Fig. D1.05)
3. Turn the spindle sleeve (28.3) with Mounting Shaft VST (29) in a clockwise direction until it rests against the hydraulic cylinder (43.4). (Fig. D1.06)
4. Lift the spindle with hydraulic cylinder (43.4).
5. Insert the Mounting Shaft VST (29) into the spindle nut (28.1). (Fig. D1.07)
6. Turn the Mounting Shaft VST (29) in a clockwise direction until the spindle nut (28.1) rests on the head plate.
7. Lower the hydraulic cylinder (43.4). (Fig. D1.08)
8. Repeat the procedure until the required height has been reached.

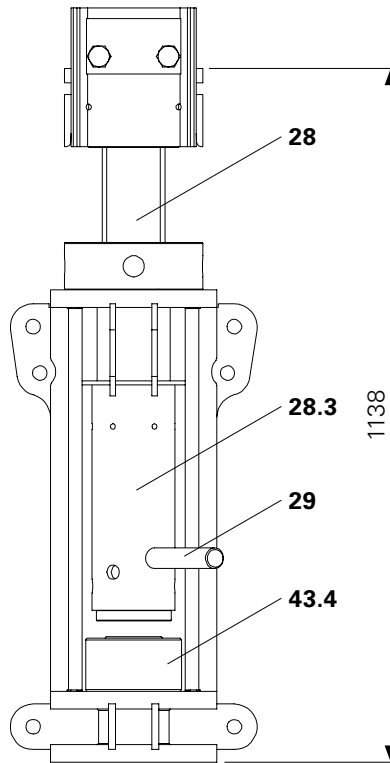

Fig. D1.05

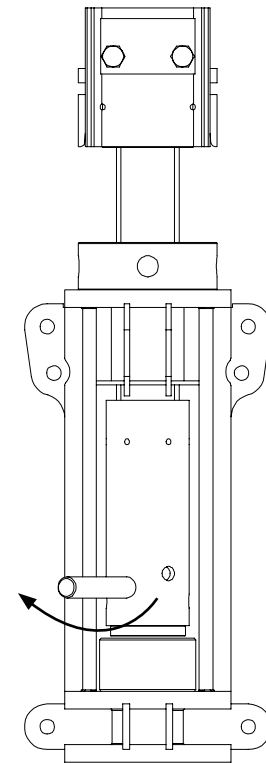

Fig. D1.06



Holes (28.4) in the spindle sleeve (28.3) serve as a visual check. When the thread is visible through these holes, the Head Spindle VST 100 (28) is within the permissible range. If this is not the case, appropriate measures must be taken in order to establish the permissible state.

Suitable measures include, e.g.
– Installation of Height Adjusts VST.

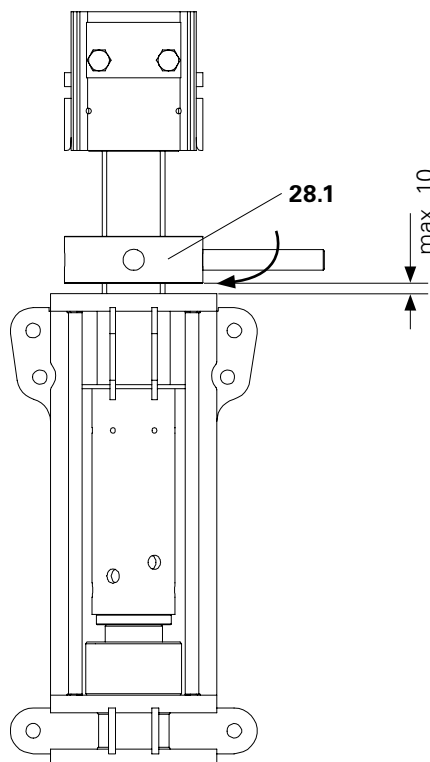

Fig. D1.07

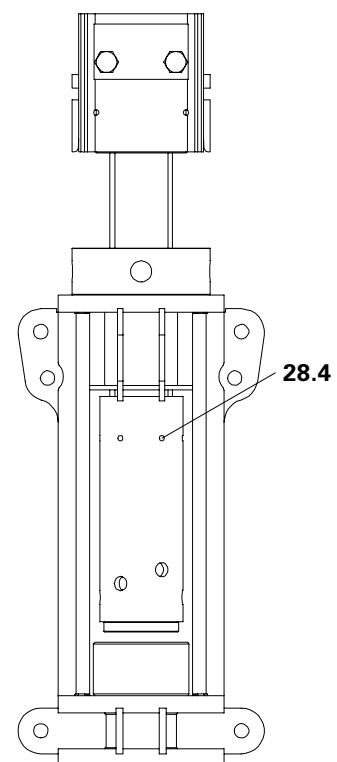

Fig. D1.08



- Follow Instructions for Use for the Hydraulic Head Spindle Device VST.
- Lowering is carried out from a safe working position.
- Project-specific lifting and lowering plans are to be observed.
- Crushing hazard when lowering.

Lowering with the hydraulic cylinder

1. Insert the Mounting Shaft VST (29) into the spindle sleeve (28.3).
2. Lower the spindle sleeve (28.3) with Mounting Shaft VST (29) until a 13 mm spacing is between the spindle sleeve (28.3) and hydraulic cylinder (43.4). (Fig. D2.01)
3. Completely extend the hydraulic cylinder (43.4) until the spindle nut (28.1) can freely move. (Fig. D2.02)
4. Insert the Mounting Shaft VST (29) into the spindle nut (28.2).
5. Turn the spindle nut (28.1) with Mounting Shaft VST (29) until there is a 10 mm spacing to the head plate. (Fig. D2.03)
6. Lower the hydraulic cylinder (43.4).

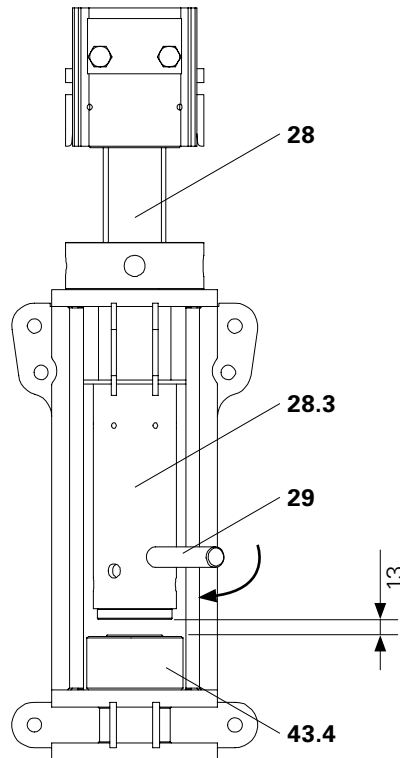

Fig. D2.01

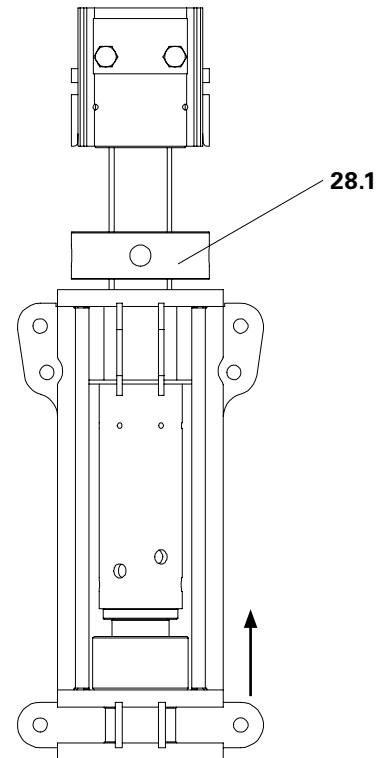

Fig. D2.02



After the procedure, the spindle sleeve (28.3) must be able to move freely. If this is not the case, the spacing between the spindle nut (28.1) and the head plate is too large. In this case, lift the spindle and adjust the spindle nut (28.1) accordingly.

7. Repeat the procedure until the planned lowering range is reached.

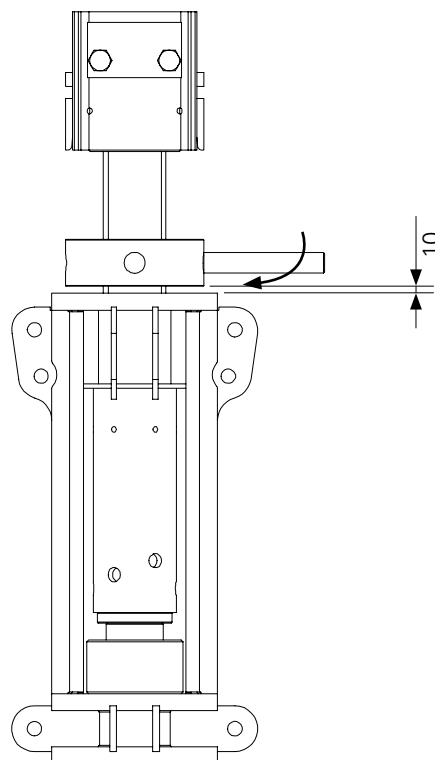

Fig. D2.03

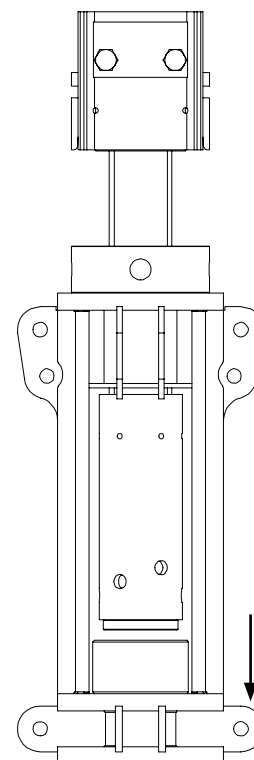

Fig. D2.04

Preparation of the towers



- Observe the information on attaching lifting gear in Section F4.
- A project-specific dismantling plan is required.
- Use lifting gear with sufficient load-bearing capacity.
- When lowering the module, ensure that no persons remain in the area of risk.
- Persons are not allowed to remain under suspended loads.



The procedure is valid for all towers.

Preparing the attached tower

1. Attach the tower segment to the crane lifting gear.
2. Dismantle the connections between the towers from a safe working position.
3. Leave the area of risk.
4. Lift off tower segment.
5. Place the tower segment on the ground for dismantling.
6. Remove crane lifting gear from the tower segment.

Preparing the bottom tower segment

1. Attach tower segment to the crane lifting gear.
2. Release anchoring.
3. Leave the area of risk.
4. Tilt the tower segment and place it on the ground for dismantling.
5. Remove crane lifting gear from the tower segment.



Use a rope to guide the tower.

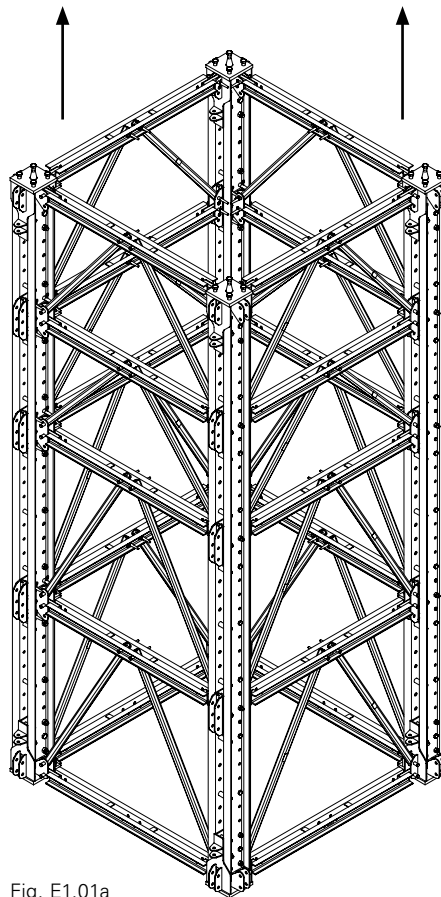

Fig. E1.01a

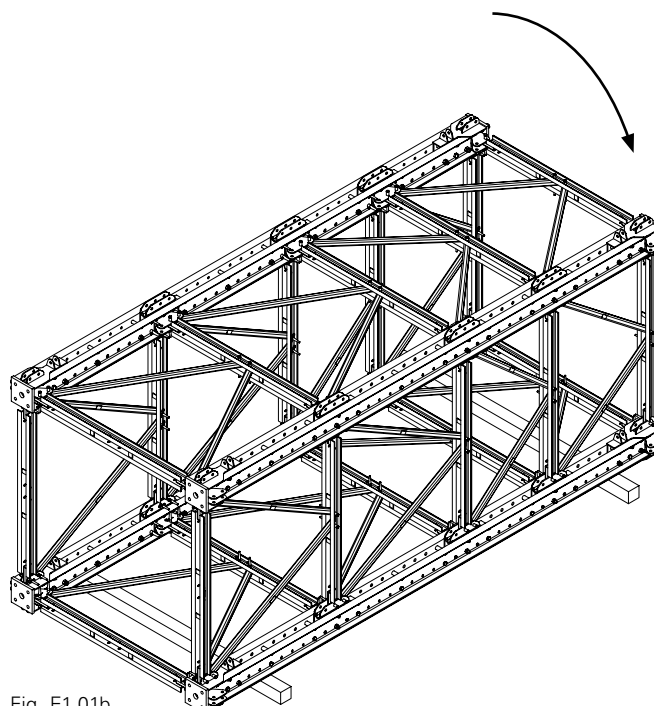

Fig. E1.01b

Module preparation



- Observe the information on attaching lifting gear in Section F3.
- Use lifting gear with sufficient load-bearing capacity.
- When lowering the module, ensure that no persons remain in the area of risk.
- Persons are not allowed to remain under suspended loads.

Preparation

1. Attach the module to the crane lifting gear.
2. Dismantle the connections and anchoring of the module.
3. Leave the area of risk.
4. Lift the module.
5. Place the module on the ground for dismantling.
6. Remove crane lifting gear from the module.

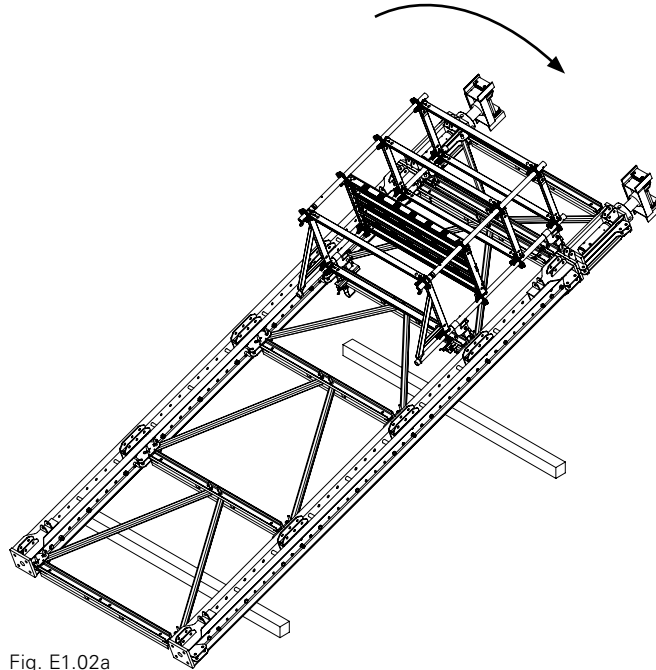

Fig. E1.02a

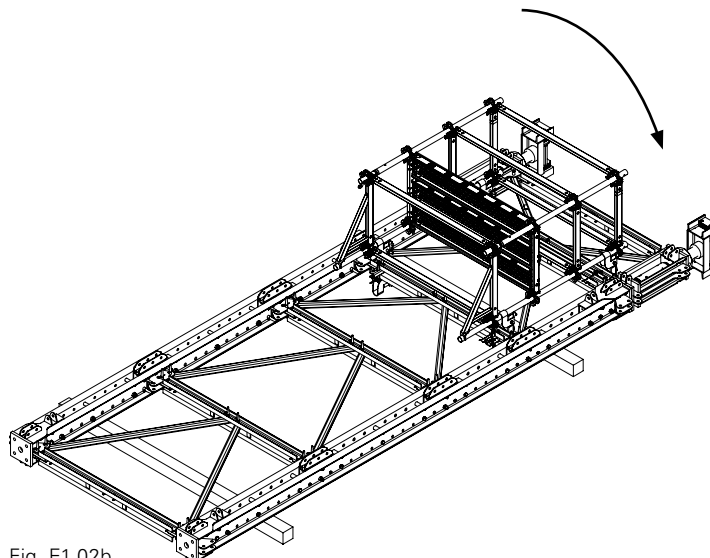

Fig. E1.02b

Dismantling the tower



Temporary situations, e.g. with timbers, must be secured to prevent any tipping over.



Vertical connecting elements (Diagonal Strut VST or Heavy-Duty Spindles SLS) must be secured against tipping over during the dismantling procedure.

Dismantling

1. Remove the diagonal connecting elements.
2. Secure the top module with the crane.
3. Remove the Fitting Pins on the vertical connecting elements at the top.
4. Set the top module down on the ground.
5. Remove crane lifting gear from the module.
6. Remove the vertical connecting elements.

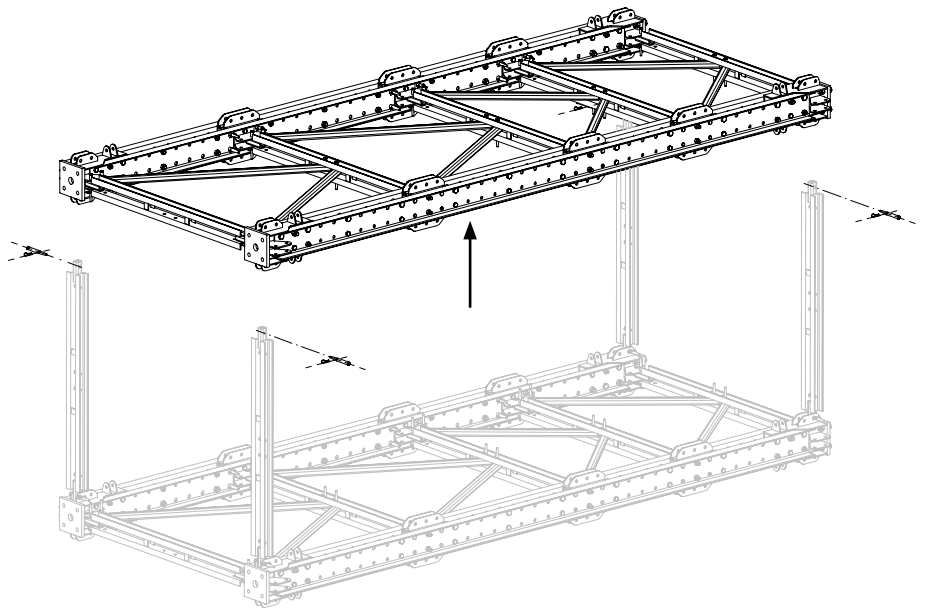

Dismantling the module



For individual components and their positions refer to the programme overview.

1. Dismantle the module.
2. Place the spacers of the RCS Rails in the correct position again. (Fig. E1.04a + E1.04b)
3. Fit the VST components with the connection means again. (Fig. E1.05a + E1.05b)

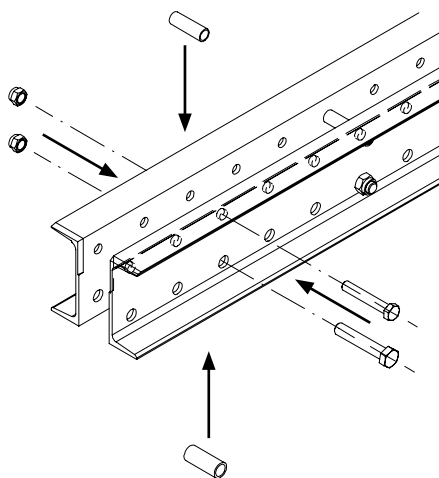

Fig. E1.04a

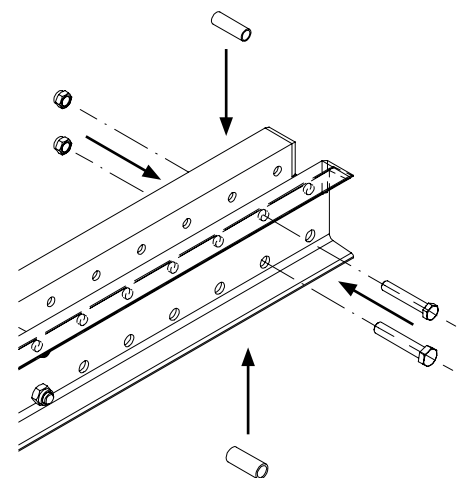

Fig. E1.04b

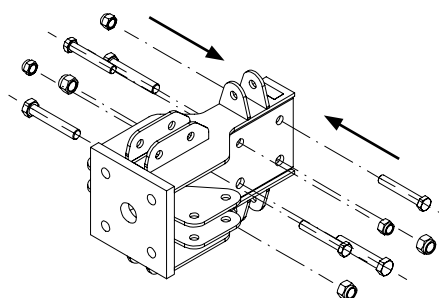

Fig. E1.05a

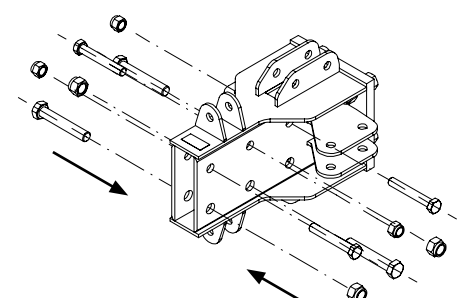

Fig. E1.05b

F1 Pre-dimensioning of the permissible leg load at the head



A detailed static calculation is required for each operation.



The tower height and a horizontal load amounting to 2.5% of the vertical load are taken into account.

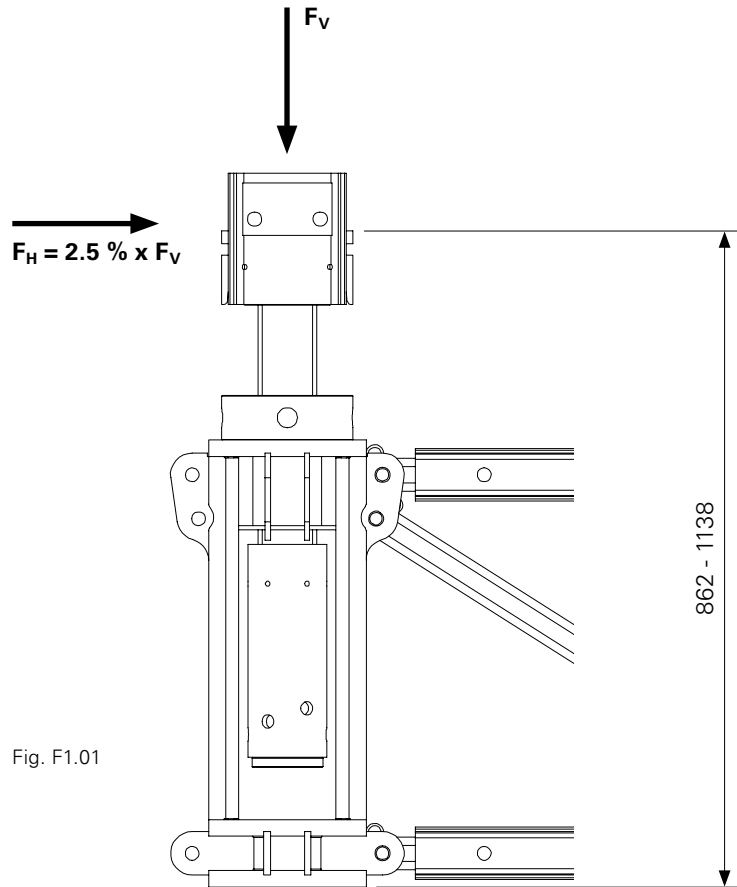

Fig. F1.01



Permissible leg loads for pre-dimensioning for a tower 2 x 2 m in accordance with Configuration 1 (Section A11) whilst taking into account a horizontal load of $F_H = 2.5\% \times F_V$. (Fig. F1.02)

Maximum leg load [kN]

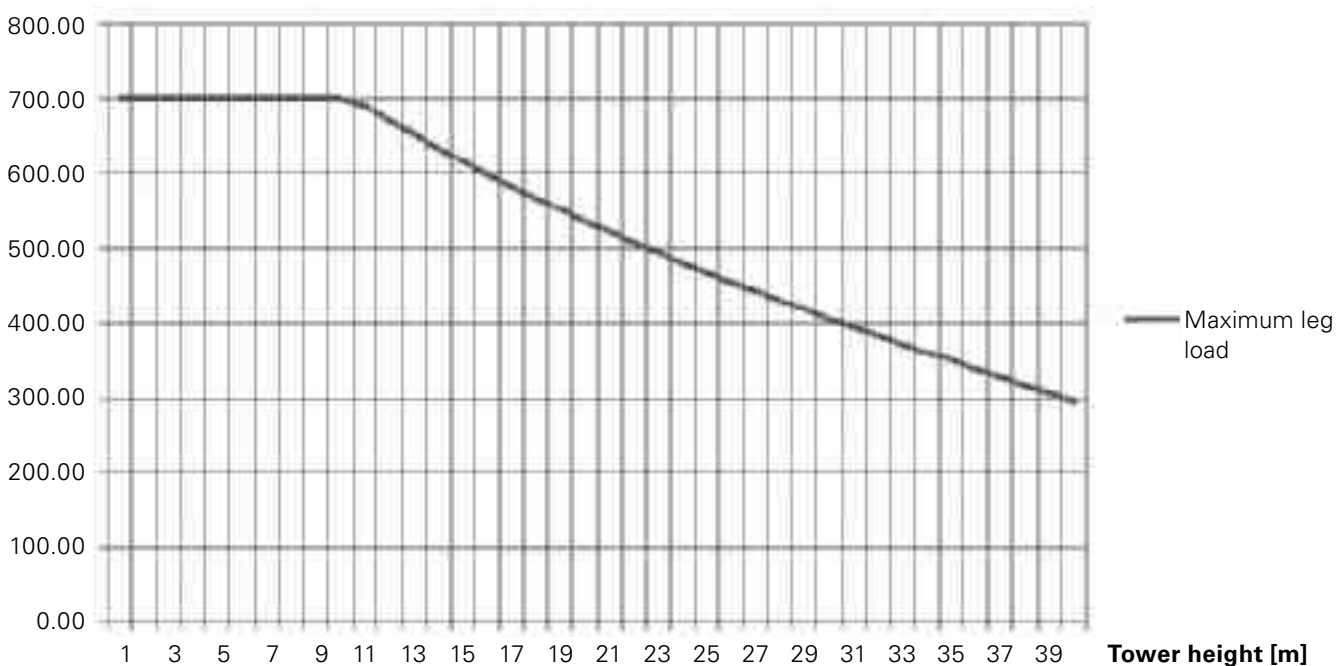

Fig. F1.02

Load-bearing point of spacers:

Spacer M20-82

Load-bearing capacity:
perm. F = 2800 kg

Spacer M24-82

Load-bearing capacity:
perm. F = 5000 kg

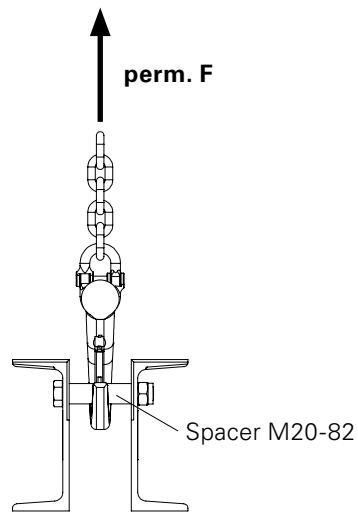

Fig. F2.01

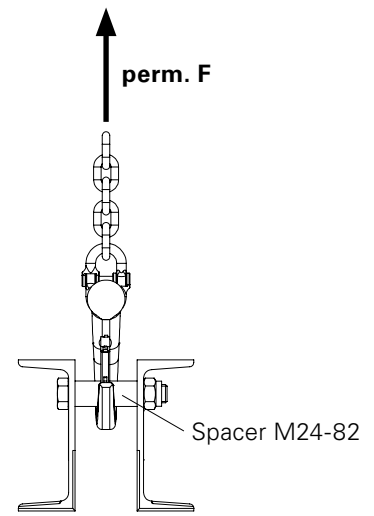

Fig. F2.02



For heavier units, project-specific attachment points and assembly sequences must be determined.



- When erecting, half the weight of the module acts on the crane lifting gear.
- Use textile lifting gear.

Without Head Spindle Frame

The lifting gear is attached to 4 Lifting Pins $\text{Ø } 21 \times 120$ (9) which are mounted on the Prop Connector VST 48 (21). (Fig. F3.03a)

Chain angle of inclination
 $\alpha = \text{max. } 30^\circ$ (Fig. F3.02)

Per load-bearing point
(Fitting Pin $\text{Ø } 21 \times 120$)

perm. F = 640 kg
 (Fig. F3.04)

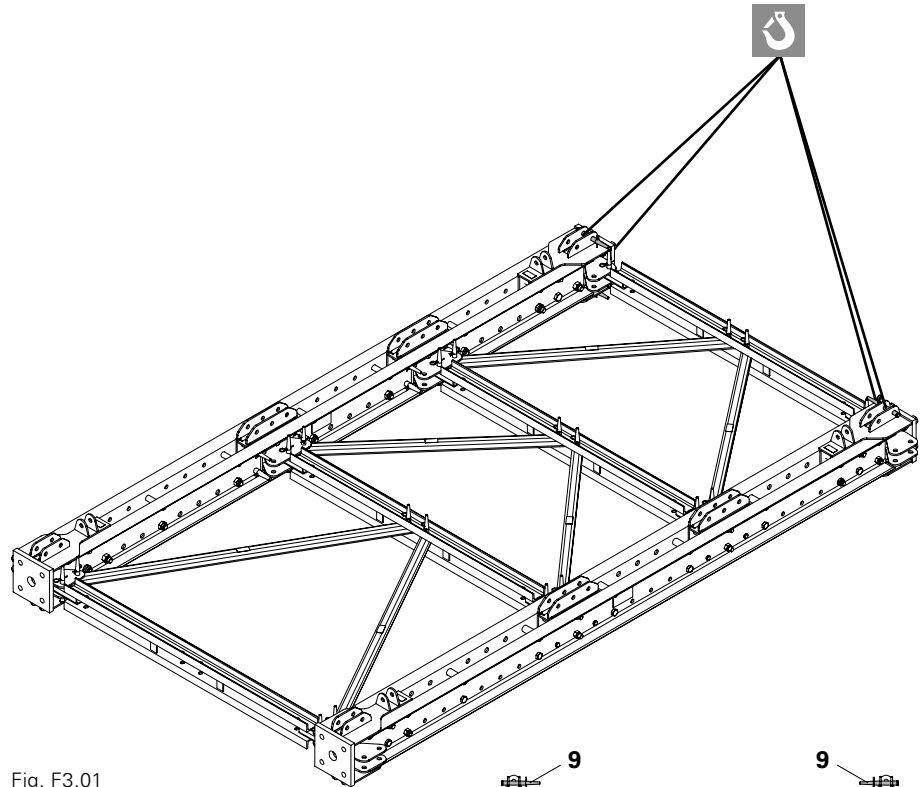

Fig. F3.01

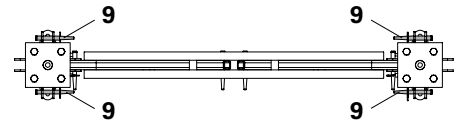

Fig. F3.03

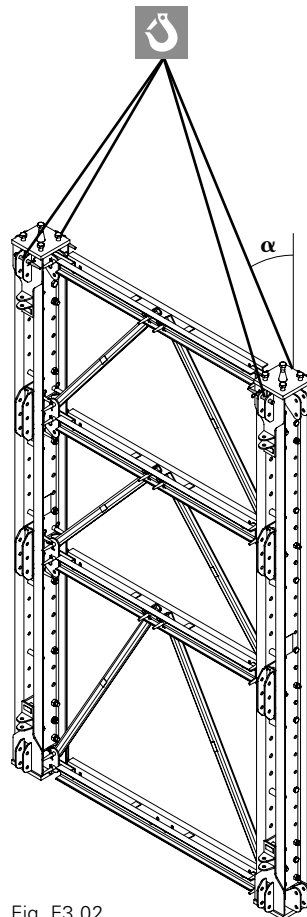

Fig. F3.02

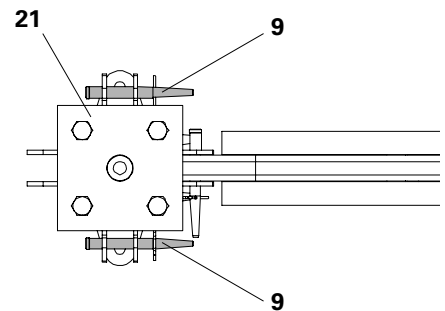

Fig. F3.03a

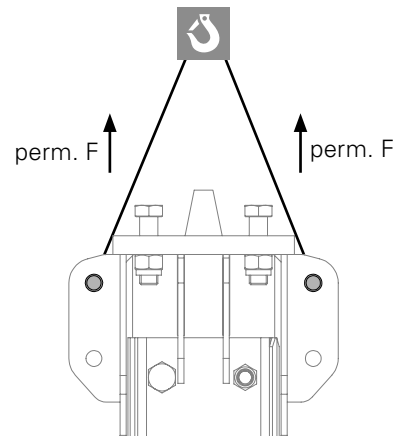

Fig. F3.04

With Head Spindle Frame

The lifting gear is connected underneath the Diagonal Struts VST 200/62.5 (27).
(Fig. F3.05)

Chain angle of inclination

$\alpha = \max. 30^\circ$
(Fig. F3.06)

Per load-bearing point (Diagonal Strut VST)

perm. $F = 6.4 \text{ kN}$
(Fig. F3.07)

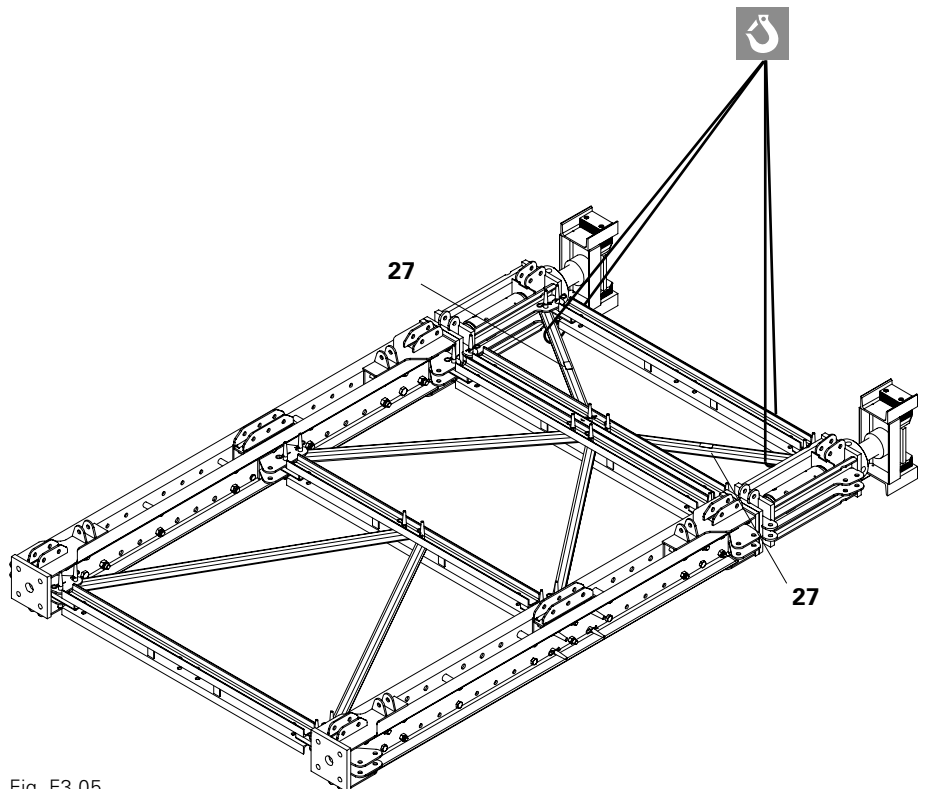

Fig. F3.05

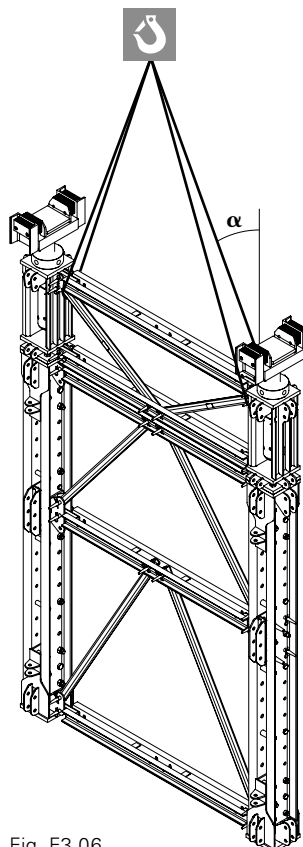

Fig. F3.06

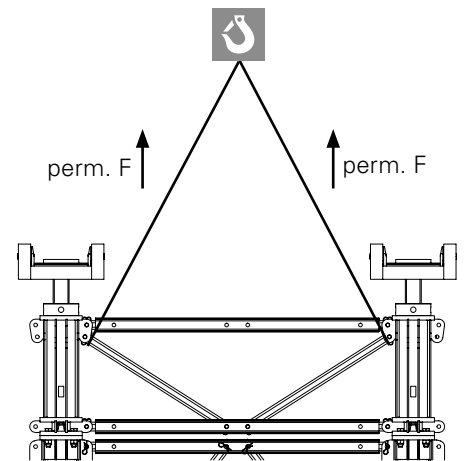

Fig. F3.07



For heavier units, project-specific attachment points and assembly sequences must be determined.



- When erecting, half the weight of the tower acts on the crane lifting gear.
- Use textile lifting gear.

Without Head Spindle Frame



When the tower is erected, the chain is redirected over the head plate. Therefore, the tower is carefully erected and directed in a forward direction.

The lifting gear is attached to 4 Lifting Pins $\varnothing 21 \times 120$ (9) which are mounted on the Prop Connector VST 48 (21). (Fig. F4.03)

Chain angle of inclination

$\alpha = \max. 30^\circ$
(Fig. F4.02)

Per load-bearing point (Fitting Pin $\varnothing 21 \times 120$)

perm. F = 640 kg
(Fig. F4.04)

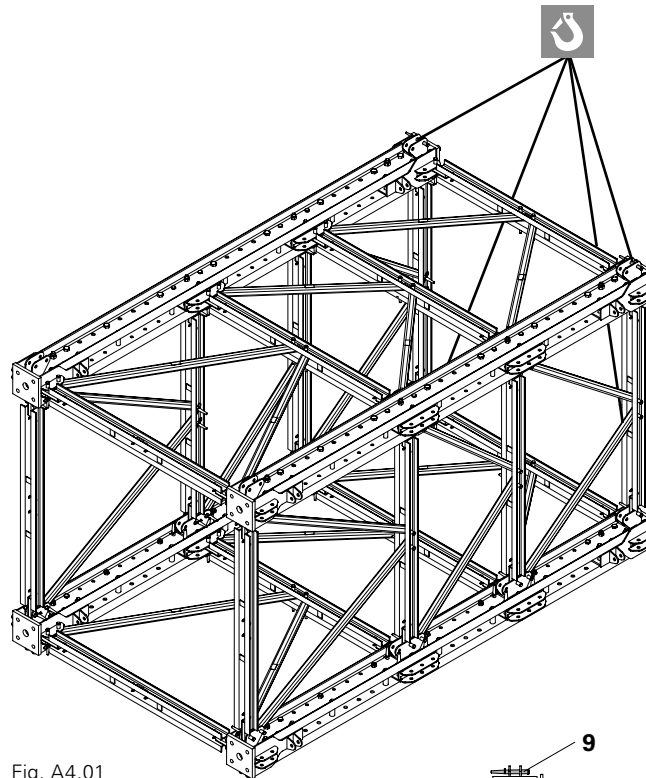

Fig. A4.01

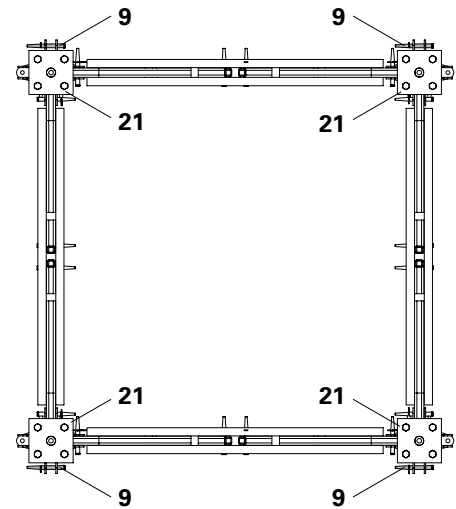

Fig. A4.03

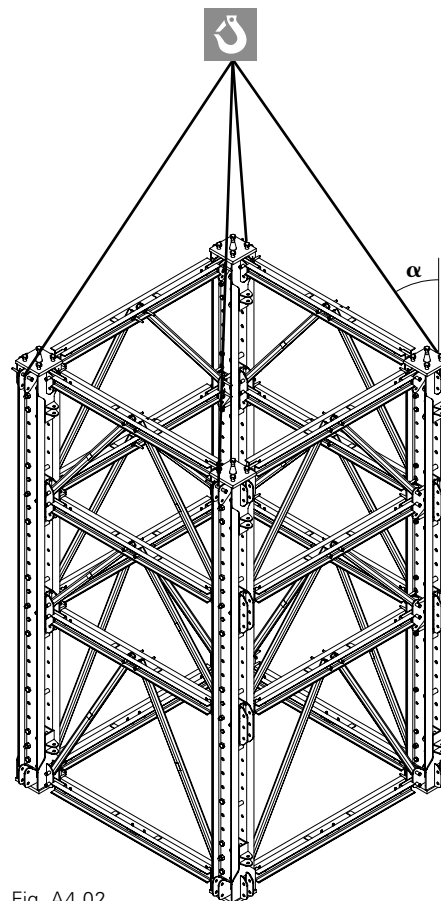

Fig. A4.02

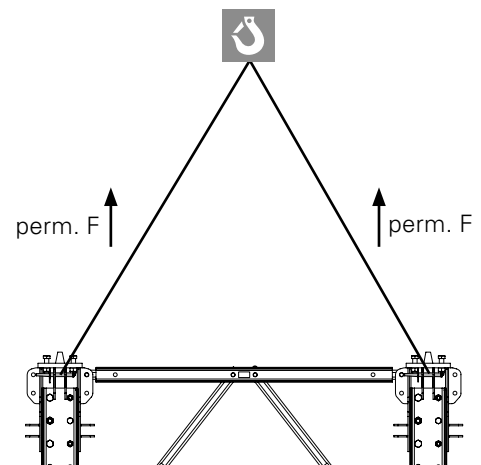

Fig. A4.04

With Head Spindle Frame

The lifting gear is connected underneath the Diagonal Struts VST 200/62.5 (27).
(Fig. F4.05)

Chain angle of inclination

$\alpha = \max. 30^\circ$
(Fig. F4.06)

Per load-bearing point (Diagonal Strut VST)

perm. F = 640 kg
(Fig. F4.07)

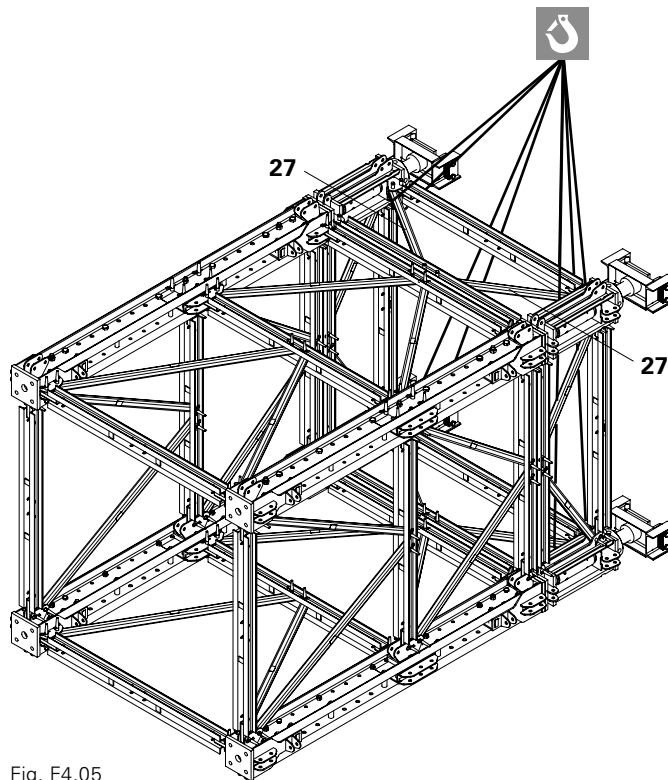

Fig. F4.05

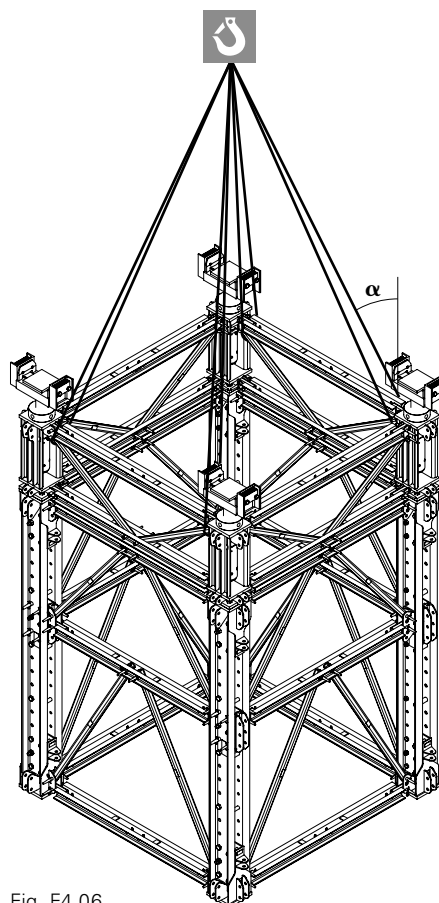

Fig. F4.06

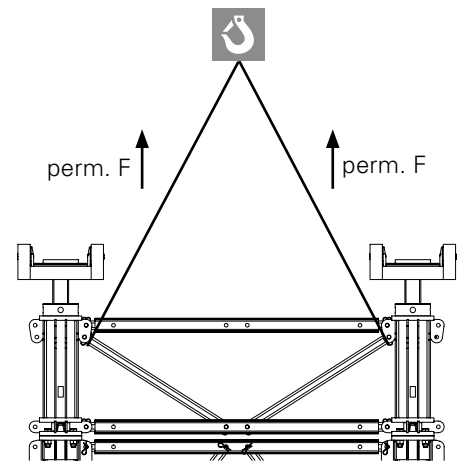

Fig. F4.07

F5 Combination Table 225 – 987.5 cm

Height			Height compensation		Head Spindle	Module						
h _{nom}	min	max	12.5	25	100	125	175	275	375	525	775	1025
					±13.8 cm							
225	211.2	238.8			1	1						
237.5	223.7	251.3	1		1	1						
250	236.2	263.8		1	1	1						
262.5	248.7	276.3	1	1	1	1						
275	261.2	288.8			1		1					
287.5	273.7	301.3	1		1		1					
300	286.2	313.8		1	1		1					
312.5	298.7	326.3	1	1	1		1					
325	311.2	338.8		2	1		1					
337.5	323.7	351.3	1	2	1		1					
350	336.2	363.8			1	2						
362.5	348.7	376.3	1		1	2						
375	361.2	388.8			1			1				
387.5	373.7	401.3	1		1			1				
400	386.2	413.8			1	1	1					
412.5	398.7	426.3	1		1	1	1					
425	411.2	438.8		1	1	1	1					
437.5	423.7	451.3	1	1	1	1	1					
450	436.2	463.8			1		2					
462.5	448.7	476.3	1		1		2					
475	461.2	488.8			1				1			
487.5	473.7	501.3	1		1				1			
500	486.2	513.8		1	1				1			
512.5	498.7	526.3	1	1	1				1			
525	511.2	538.8		1	1	1		1				
537.5	523.7	551.3	1	1	1	1		1				
550	536.2	563.8			1		1	1				
562.5	548.7	576.3	1		1		1	1				
575	561.2	588.8			1	1	2					
587.5	573.7	601.3	1		1	1	2					
600	586.2	613.8			1	1			1			
612.5	598.7	626.3	1		1	1			1			
625	611.2	638.8			1					1		
637.5	623.7	651.3	1		1					1		
650	636.2	663.8		1	1					1		
662.5	648.7	676.3	1	1	1					1		
675	661.2	688.8		1	1		1		1			
687.5	673.7	701.3	1	1	1		1		1			
700	686.2	713.8			1	2	2					
712.5	698.7	726.3	1		1	2	2					
725	711.2	738.8			1	2			1			
737.5	723.7	751.3	1		1	2			1			

F5 Combination Table 225 – 987.5 cm

Height			Height compensation		Head Spindle	Module						
h _{nom}	min	max	12.5	25	100	125	175	275	375	525	775	1025
					±13.8 cm							
750	736.2	763.8			1	1				1		
762.5	748.7	776.3	1		1	1				1		
775	761.2	788.8		1	1	1				1		
787.5	773.7	801.3	1	1	1	1				1		
800	786.2	813.8			1		1			1		
812.5	798.7	826.3	1		1		1			1		
825	811.2	838.8		1	1		1			1		
837.5	823.7	851.3	1	1	1		1			1		
850	836.2	863.8			1				2			
862.5	848.7	876.3	1		1				2			
875	861.2	888.8			1						1	
887.5	873.7	901.3	1		1						1	
900	886.2	913.8		1	1						1	
912.5	898.7	926.3	1	1	1						1	
925	911.2	938.8		1	1			1		1		
937.5	923.7	951.3	1	1	1			1		1		
950	936.2	963.8		1	1	1	1			1		
962.5	948.7	976.3	1	1	1	1	1			1		
975	961.2	988.8			1	1			2			
987.5	973.7	1001.3	1		1	1			2			

Table F5.01

For lowering, a remaining distance for the spindle of approx. 8 cm is to be planned.

F6 Combination Table 1000 – 1987.5 cm

Height			Height compensation		Head Spindle	Module						
h_{nom}	min	max	12.5	25	100	125	175	275	375	525	775	1025
					± 13.8 cm							
1000	986.2	1013.8			1	1					1	
1012.5	998.7	1026.3	1		1	1					1	
1025	1011.2	1038.8		1	1	1					1	
1037.5	1023.7	1051.3	1	1	1	1					1	
1050	1036.2	1063.8			1		1				1	
1062.5	1048.7	1076.3	1		1		1				1	
1075	1061.2	1088.8		1	1		1				1	
1087.5	1073.7	1101.3	1	1	1		1				1	
1100	1086.2	1113.8		1	1		1	1		1		
1112.5	1098.7	1126.3	1	1	1		1	1		1		
1125	1111.2	1138.8			1							1
1137.5	1123.7	1151.3	1		1							1
1150	1136.2	1163.8		1	1							1
1162.5	1148.7	1176.3	1	1	1							1
1175	1161.2	1188.8		1	1					2		
1187.5	1173.7	1201.3	1	1	1					2		
1200	1186.2	1213.8		1	1			2		1		
1212.5	1198.7	1226.3	1	1	1			2		1		
1225	1211.2	1238.8			1				3			
1237.5	1223.7	1251.3	1		1				3			
1250	1236.2	1263.8			1				1		1	
1262.5	1248.7	1276.3	1		1				1		1	
1275	1261.2	1288.8		1	1				1		1	
1287.5	1273.7	1301.3	1	1	1				1		1	
1300	1286.2	1313.8			1		1					1
1312.5	1298.7	1326.3	1		1		1					1
1325	1311.2	1338.8		1	1		1					1
1337.5	1323.7	1351.3	1	1	1		1					1
1350	1336.2	1363.8		2	1		1					1
1362.5	1348.7	1376.3	1	2	1		1					1
1375	1361.2	1388.8			1	1			1		1	
1387.5	1373.7	1401.3	1		1	1			1		1	
1400	1386.2	1413.8			1					1	1	
1412.5	1398.7	1426.3	1		1					1	1	
1425	1411.2	1438.8		1	1					1	1	
1437.5	1423.7	1451.3	1	1	1					1	1	
1450	1436.2	1463.8		1	1		1		1		1	
1462.5	1448.7	1476.3	1	1	1		1		1		1	
1475	1461.2	1488.8			1		2					1
1487.5	1473.7	1501.3	1		1		2					1
1500	1486.2	1513.8			1				1			1
1512.5	1498.7	1526.3	1		1				1			1

F6 Combination Table 1000 – 1987.5 cm

Height			Height compensation		Head Spindle	Module						
h _{nom}	min	max	12.5	25	100	125	175	275	375	525	775	1025
					±13.8 cm							
1525	1511.2	1538.8		1	1				1			1
1537.5	1523.7	1551.3	1	1	1				1			1
1550	1536.2	1563.8		1	1	1		1				1
1562.5	1548.7	1576.3	1	1	1	1		1				1
1575	1561.2	1588.8			1		1			1	1	
1587.5	1573.7	1601.3	1		1		1			1	1	
1600	1586.2	1613.8			1		1	1		2		
1612.5	1598.7	1626.3	1		1		1	1		2		
1625	1611.2	1638.8			1				2		1	
1637.5	1623.7	1651.3	1		1				2		1	
1650	1636.2	1663.8			1						2	
1662.5	1648.7	1676.3	1		1						2	
1675	1661.2	1688.8		1	1						2	
1687.5	1673.7	1701.3	1	1	1						2	
1700	1686.2	1713.8		1	1			1		1	1	
1712.5	1698.7	1726.3	1	1	1			1		1	1	
1725	1711.2	1738.8		1	1	1	1	1				1
1737.5	1723.7	1751.3	1	1	1	1	1	1				1
1750	1736.2	1763.8			1	2			1			1
1762.5	1748.7	1776.3	1		1	2			1			1
1775	1761.2	1788.8			1	1					2	
1787.5	1773.7	1801.3	1		1	1					2	
1800	1786.2	1813.8		1	1	1					2	
1812.5	1798.7	1826.3	1	1	1	1					2	
1825	1811.2	1838.8			1		1				2	
1837.5	1823.7	1851.3	1		1		1				2	
1850	1836.2	1863.8		1	1		1			1		1
1862.5	1848.7	1876.3	1	1	1		1			1		1
1875	1861.2	1888.8			1				2			1
1887.5	1873.7	1901.3	1		1				2			1
1900	1886.2	1913.8			1						1	1
1912.5	1898.7	1926.3	1		1						1	1
1925	1911.2	1938.8		1	1						1	1
1937.5	1923.7	1951.3	1	1	1						1	1
1950	1936.2	1963.8		2	1						1	1
1962.5	1948.7	1976.3	1	2	1						1	1
1975	1961.2	1988.8		1	1	1	1			1		1
1987.5	1973.7	2001.3	1	1	1	1	1			1		1

Table F6.01

For lowering, a remaining distance for the spindle of approx. 8 cm is to be planned.

F7 Combination Table 2000 – 2987.5 cm



Height			Height compensation		Head Spindle	Module						
h_{nom}	min	max	12.5	25	100	125	175	275	375	525	775	1025
					± 13.8 cm							
2000	1986.2	2013.8			1	1			2			1
2012.5	1998.7	2026.3	1		1	1			2			1
2025	2011.2	2038.8			1				1		2	
2037.5	2023.7	2051.3	1		1				1		2	
2050	2036.2	2063.8		1	1	1					1	1
2062.5	2048.7	2076.3	1	1	1	1					1	1
2075	2061.2	2088.8			1		1				1	1
2087.5	2073.7	2101.3	1		1		1				1	1
2100	2086.2	2113.8		1	1		1				1	1
2112.5	2098.7	2126.3	1	1	1		1				1	1
2125	2111.2	2138.8		1	1		1			2	1	
2137.5	2123.7	2151.3	1	1	1		1			2	1	
2150	2136.2	2163.8			1							2
2162.5	2148.7	2176.3	1		1							2
2175	2161.2	2188.8		1	1							2
2187.5	2173.7	2201.3	1	1	1							2
2200	2186.2	2213.8		1	1					2		1
2212.5	2198.7	2226.3	1	1	1					2		1
2225	2211.2	2238.8		1	1			2		1		1
2237.5	2223.7	2251.3	1	1	1			2		1		1
2250	2236.2	2263.8			1				3			1
2262.5	2248.7	2276.3	1		1				3			1
2275	2261.2	2288.8			1				1		1	1
2287.5	2273.7	2301.3	1		1				1		1	1
2300	2286.2	2313.8			1	1				1	2	
2312.5	2298.7	2326.3	1		1	1				1	2	
2325	2311.2	2338.8			1		1					2
2337.5	2323.7	2351.3	1		1		1					2
2350	2336.2	2363.8		1	1		1					2
2362.5	2348.7	2376.3	1	1	1		1					2
2375	2361.2	2388.8		1	1		1	1			1	1
2387.5	2373.7	2401.3	1	1	1		1	1			1	1
2400	2386.2	2413.8			1				2		2	
2412.5	2398.7	2426.3	1		1				2		2	
2425	2411.2	2438.8			1					1	1	1
2437.5	2423.7	2451.3	1		1					1	1	1
2450	2436.2	2463.8		1	1					1	1	1
2462.5	2448.7	2476.3	1	1	1					1	1	1
2475	2461.2	2488.8		1	1		1		1		1	1
2487.5	2473.7	2501.3	1	1	1		1		1		1	1
2500	2486.2	2513.8			1		2					2
2512.5	2498.7	2526.3	1		1		2					2

F7 Combination Table 2000 – 2987.5 cm

Height			Height compensation		Head Spindle	Module						
h _{nom}	min	max	12.5	25	100	125	175	275	375	525	775	1025
					±13.8 cm							
2525	2511.2	2538.8			1				1			2
2537.5	2523.7	2551.3	1		1				1			2
2550	2536.2	2563.8		1	1				1			2
2562.5	2548.7	2576.3	1	1	1				1			2
2575	2561.2	2588.8		1	1	1		1				2
2587.5	2573.7	2601.3	1	1	1	1		1				2
2600	2586.2	2613.8			1		1			1	1	1
2612.5	2598.7	2626.3	1		1		1			1	1	1
2625	2611.2	2638.8			1		1	1		1	2	
2637.5	2623.7	2651.3	1		1		1	1		1	2	
2650	2636.2	2663.8			1				2		1	1
2662.5	2648.7	2676.3	1		1				2		1	1
2675	2661.2	2688.8			1						2	1
2687.5	2673.7	2701.3	1		1						2	1
2700	2686.2	2713.8		1	1						2	1
2712.5	2698.7	2726.3	1	1	1						2	1
2725	2711.2	2738.8		1	1			1		1	1	1
2737.5	2723.7	2751.3	1	1	1			1		1	1	1
2750	2736.2	2763.8		1	1	1	1	1				2
2762.5	2748.7	2776.3	1	1	1	1	1	1				2
2775	2761.2	2788.8			1				3		2	
2787.5	2773.7	2801.3	1		1				3		2	
2800	2786.2	2813.8			1	1					2	1
2812.5	2798.7	2826.3	1		1	1					2	1
2825	2811.2	2838.8		1	1	1					2	1
2837.5	2823.7	2851.3	1	1	1	1					2	1
2850	2836.2	2863.8			1		1			1		2
2862.5	2848.7	2876.3	1		1		1			1		2
2875	2861.2	2888.8		1	1		1			1		2
2887.5	2873.7	2901.3	1	1	1		1			1		2
2900	2886.2	2913.8			1				2			2
2912.5	2898.7	2926.3	1		1				2			2
2925	2911.2	2938.8			1						1	2
2937.5	2923.7	2951.3	1		1						1	2
2950	2936.2	2963.8			1					1	3	
2962.5	2948.7	2976.3	1		1					1	3	
2975	2961.2	2988.8		1	1			1		1		2
2987.5	2973.7	3001.3	1	1	1			1		1		2

Table F7.01

For lowering, a remaining distance for the spindle of approx. 8 cm is to be planned.

F8 Combination Table 3000 – 4000 cm



Height			Height compensation		Head Spindle	Module						
h _{nom}	min	max	12.5	25	100	125	175	275	375	525	775	1025
					±13.8 cm							
3000	2986.2	3013.8		1	1	1	1			1		2
3012.5	2998.7	3026.3	1	1	1	1	1			1		2
3025	3011.2	3038.8			1	1			2			2
3037.5	3023.7	3051.3	1		1	1			2			2
3050	3036.2	3063.8			1				1		2	1
3062.5	3048.7	3076.3	1		1				1		2	1
3075	3061.2	3088.8		1	1	1					1	2
3087.5	3073.7	3101.3	1	1	1	1					1	2
3100	3086.2	3113.8			1		1				1	2
3112.5	3098.7	3126.3	1		1		1				1	2
3125	3111.2	3138.8		1	1		1				1	2
3137.5	3123.7	3151.3	1	1	1		1				1	2
3150	3136.2	3163.8		1	1		1			2	1	1
3162.5	3148.7	3176.3	1	1	1		1			2	1	1
3175	3161.2	3188.8			1							3
3187.5	3173.7	3201.3	1		1							3
3200	3186.2	3213.8		1	1							3
3212.5	3198.7	3226.3	1	1	1							3
3225	3211.2	3238.8		1	1					2		2
3237.5	3223.7	3251.3	1	1	1					2		2
3250	3236.2	3263.8		1	1			2		1		2
3262.5	3248.7	3276.3	1	1	1			2		1		2
3275	3261.2	3288.8			1				3			2
3287.5	3273.7	3301.3	1		1				3			2
3300	3286.2	3313.8			1				1		1	2
3312.5	3298.7	3326.3	1		1				1		1	2
3325	3311.2	3338.8			1				1	1	3	
3337.5	3323.7	3351.3	1		1				1	1	3	
3350	3336.2	3363.8			1		1					3
3362.5	3348.7	3376.3	1		1		1					3
3375	3361.2	3388.8		1	1		1					3
3387.5	3373.7	3401.3	1	1	1		1					3
3400	3386.2	3413.8		1	1		1	1			1	2
3412.5	3398.7	3426.3	1	1	1		1	1			1	2
3425	3411.2	3438.8			1				2		2	1
3437.5	3423.7	3451.3	1		1				2		2	1
3450	3436.2	3463.8			1					1	1	2
3462.5	3448.7	3476.3	1		1					1	1	2
3475	3461.2	3488.8		1	1					1	1	2
3487.5	3473.7	3501.3	1	1	1					1	1	2
3500	3486.2	3513.8			1			2		1	3	
3512.5	3498.7	3526.3	1		1			2		1	3	

F8 Combination Table 3000 – 4000 cm

Height			Height compensation		Head Spindle	Module						
h _{nom}	min	max	12.5	25	100	125	175	275	375	525	775	1025
					±13.8 cm							
3525	3511.2	3538.8			1		2					3
3537.5	3523.7	3551.3	1		1		2					3
3550	3536.2	3563.8			1				1			3
3562.5	3548.7	3576.3	1		1				1			3
3575	3561.2	3588.8		1	1				1			3
3587.5	3573.7	3601.3	1	1	1				1			3
3600	3586.2	3613.8			1				1	3	2	
3612.5	3598.7	3626.3	1		1				1	3	2	
3625	3611.2	3638.8			1		1			1	1	2
3637.5	3623.7	3651.3	1		1		1			1	1	2
3650	3636.2	3663.8			1		1			2	3	
3662.5	3648.7	3676.3	1		1		1			2	3	
3675	3661.2	3688.8			1				2		1	2
3687.5	3673.7	3701.3	1		1				2		1	2
3700	3686.2	3713.8			1						2	2
3712.5	3698.7	3726.3	1		1						2	2
3725	3711.2	3738.8		1	1						2	2
3737.5	3723.7	3751.3	1	1	1						2	2
3750	3736.2	3763.8		1	1			1		1	1	2
3762.5	3748.7	3776.3	1	1	1			1		1	1	2
3775	3761.2	3788.8			1	1	1			2	3	
3787.5	3773.7	3801.3	1		1	1	1			2	3	
3800	3786.2	3813.8			1				3		2	1
3812.5	3798.7	3826.3	1		1				3		2	1
3825	3811.2	3838.8			1				1		3	1
3837.5	3823.7	3851.3	1		1				1		3	1
3850	3836.2	3863.8		1	1	1					2	2
3862.5	3848.7	3876.3	1	1	1	1					2	2
3875	3861.2	3888.8			1		1				2	2
3887.5	3873.7	3901.3	1		1		1				2	2
3900	3886.2	3913.8		1	1		1			1		3
3912.5	3898.7	3926.3	1	1	1		1			1		3
3925	3911.2	3938.8			1				2			3
3937.5	3923.7	3951.3	1		1				2			3
3950	3936.2	3963.8			1							3
3962.5	3948.7	3976.3	1		1							3
3975	3961.2	3988.8			1					1		1
3987.5	3973.7	4001.3	1		1					1		1
4000	3986.2	4013.8			1					3		

Table F8.01

For lowering, a remaining distance for the spindle of approx. 8 cm is to be planned.

Item no.	Weight kg
117465	172.000

Head Spindle VST 100

Head Spindle for VARIOKIT Heavy Duty Shoring Tower. Optional to use with Hydraulic Unit.

Technical Data

Permissible load-bearing capacity 70 t.

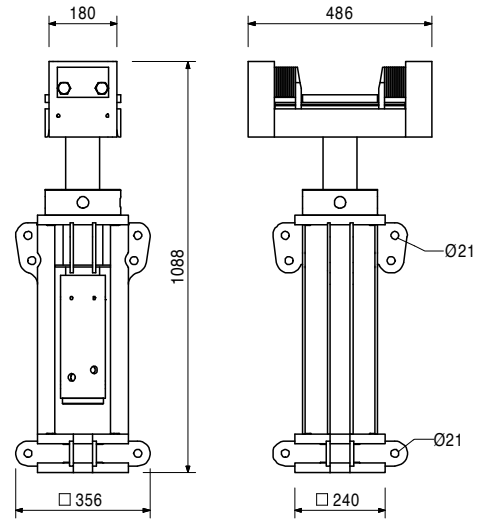
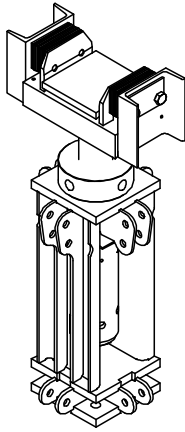

Accessories

117377	1.030
117678	17.400

Assembly Handhold VST Hydraulic Unit VST

117454	48.200
--------	--------

Prop Connector VST 48

For connecting Climbing Rails RCS with Head Spindle VST or Height Adjust VST.

Complete with

- 3 pc. 114563 Bolt ISO 4014 M24 x 140-10.9
- 3 pc. 105032 Nut ISO 7042 M24-8, galv.
- 3 pc. 117452 Bolt ISO 4014 M20 x 130-10.9
- 3 pc. 781053 Nut ISO 7042 M20-8, galv.
- 4 pc. 105416 Bolt ISO 4014 M24 x 80-8.8, galv.

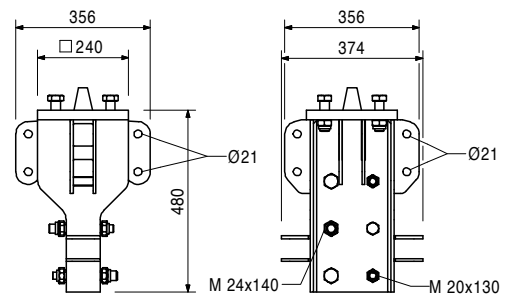
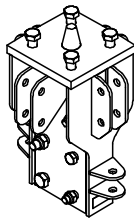

117453	45.500
--------	--------

Prop Base VST 48

Prop Base for VARIOKIT Heavy Duty Shoring Tower with connection for Climbing Rail RCS.

Complete with

- 3 pc. 114563 Bolt ISO 4014 M24 x 140-10.9
- 3 pc. 105032 Nut ISO 7042 M24-8, galv.
- 3 pc. 117452 Bolt ISO 4014 M20 x 130-10.9
- 3 pc. 781053 Nut ISO 7042 M20-8, galv.

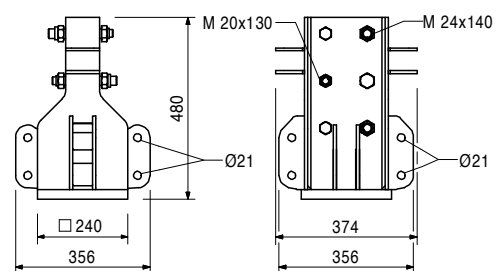
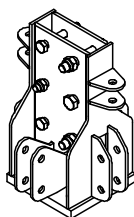

VST Heavy Duty Shoring Tower



Item no.	Weight kg
117391	35.400

Height Adjust VST 25
As 25 cm height compensation.

Complete with
4 pc. 105416 Bolt ISO 4014 M24 x 80-8.8, galv.
4 pc. 105032 Nut ISO 7042 M24-8, galv.

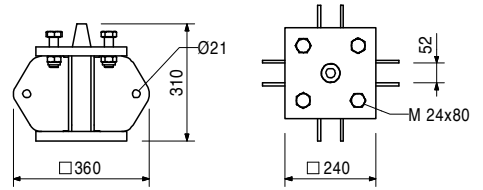
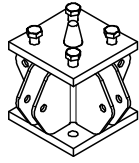

117433	28.900
--------	--------

Height Adjust VST 12.5
As 12.5 cm height compensation.

Complete with
4 pc. 117429 Thread Bolt VST M24, galv.
8 pc. 105032 Nut ISO 7042 M24-8, galv.

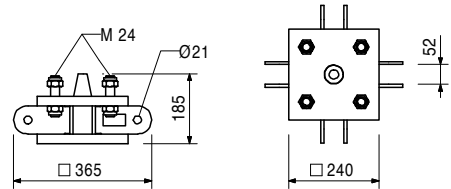
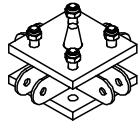

117425	7.090
--------	-------

Cross Connector VST
For connecting Horizontal Ledgers VST and Diagonal Struts VST cross to the direction of the frame.

Complete with
2 pc. 113994 Bolt ISO 4014 M20 x 140-8.8, galv.
2 pc. 781053 Nut ISO 7042 M20-8, galv.
1 pc. 117492 Sleeve VST, galv.

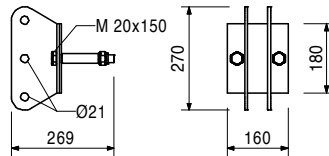
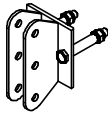

VST Heavy Duty Shoring Tower



Item no.	Weight kg
117411	18.600

Bracing Connector VST

For connecting Horizontal Ledgers VST and Diagonal Struts VST in direction of the frame.

Complete with

- 2 pc. 104031 Fitting Pin \varnothing 21 x 120
- 2 pc. 111567 Fitting Pin \varnothing 26 x 120
- 2 pc. 018060 Cotter Pin 4/1, galv.
- 2 pc. 022230 Cotter Pin 5/1, galv.

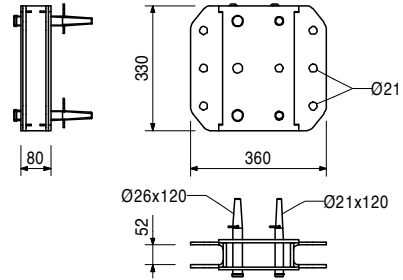
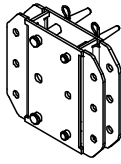

Item no.	Weight kg
117371	31.400

Horizontal Ledger VST 200

As Horizontal Ledger for the legs. Results in a leg distance of 2.00 m.

Complete with

- 2 pc. 104031 Fitting Pin \varnothing 21 x 120
- 2 pc. 018060 Cotter Pin 4/1, galv.

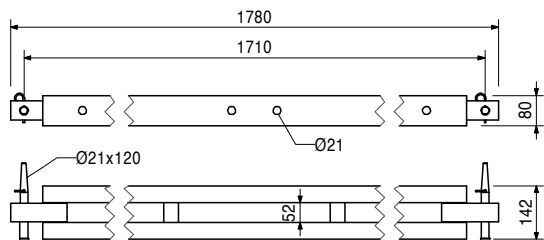
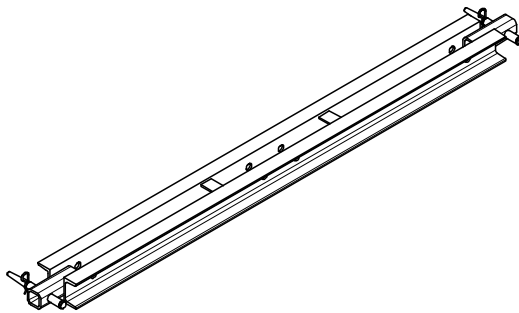

Item no.	Weight kg
117504	21.700

Horizontal Brace VST 200/200

For horizontal bracing of the legs.

Complete with

- 2 pc. 105400 Pin \varnothing 20 x 140, galv.
- 2 pc. 018060 Cotter Pin 4/1, galv.

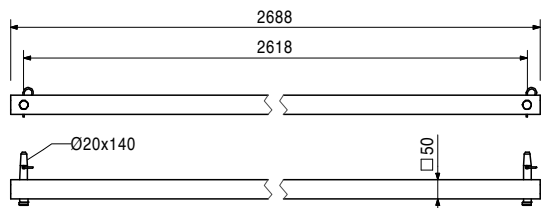
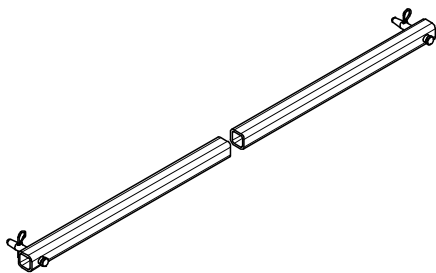

VST Heavy Duty Shoring Tower

Item no. Weight kg

		Diagonal Struts VST
117388	8.910	Diagonal Strut VST 200/62.5
117382	10.900	Diagonal Strut VST 200/100
117385	11.700	Diagonal Strut VST 200/112.5
117379	14.100	Diagonal Strut VST 200/150

L	X
1019	953
1271	1201
1367	1297
1680	1610

Complete with

2 pc. 104031 Fitting Pin Ø 21 x 120
2 pc. 018060 Cotter Pin 4/1, galv.

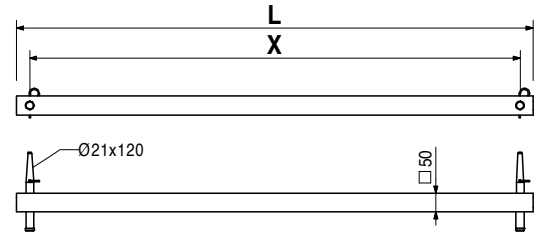
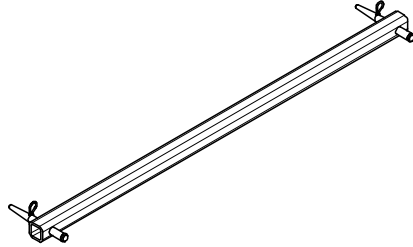

117696 2.130

Horizontal Connector VST

To connect additional legs to the standard frames.
Spacing 375 mm.

Complete with

2 pc. 104031 Fitting Pin Ø 21 x 120
2 pc. 018060 Cotter Pin 4/1, galv.

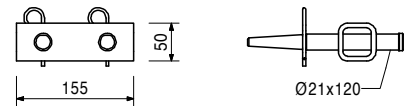
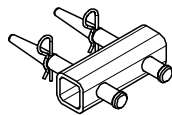

117712 35.700

Leg-Connector VST

To connect additional legs to the standard frames.
Spacing 375 mm.

Complete with

4 pc. 104031 Fitting Pin Ø 21 x 120
4 pc. 018060 Cotter Pin 4/1, galv.

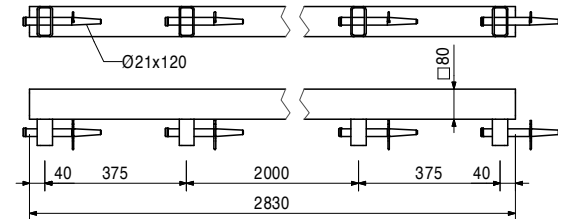
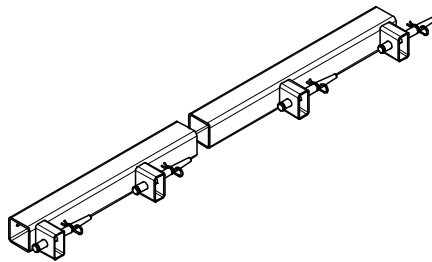

123823 4.160

Adapter VST- SRU

Adapter for connecting SRU-Ledger as Horizontal Ledger to VARIOKIT Heavy Duty Shoring Tower.

Complete with

3 pc. 104031 Fitting Pin Ø 21 x 120
3 pc. 018060 Cotter Pin 4/1, galv.

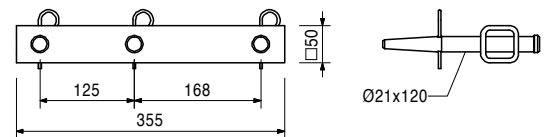
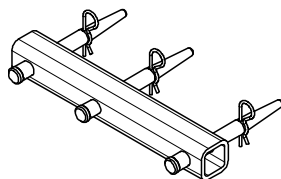

VST Heavy Duty Shoring Tower



Item no.	Weight kg
117707	9.200

Connector UP-VST

Adaptor for mounting PERI UP scaffold parts to the VARIOKIT Heavy Duty Shoring Tower.

Complete with

- 1 pc. 104031 Fitting Pin \varnothing 21 x 120
- 2 pc. 105400 Pin \varnothing 20 x 140, galv.
- 3 pc. 018060 Cotter Pin 4/1, galv.
- 2 pc. 117701 Connection Plate Pcoat
- 1 pc. 024250 Wedge K, galv.

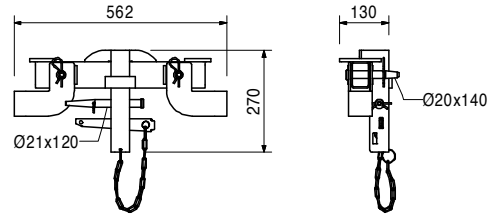
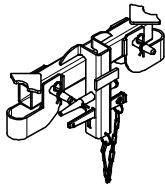

117377	1.030
--------	-------

Assembly Handhold VST

For adjusting Head Spindle VST 100.

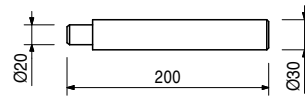
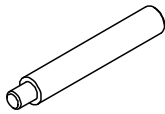

117678	17.400
--------	--------

Hydraulic Unit VST

Flexible hydraulic unit for the use in the Head Spindle VST 100.

Note

Follow Instructions for Use!

Technical Data

Stroke height 16 mm.

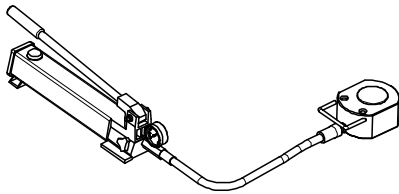

VST Heavy Duty Shoring Tower

Item no. Weight kg

Item no.	Weight kg	Steel Waler Universal SRU
103868	18.100	Steel Waler Universal SRU U120, l = 0.72 m
103871	24.200	Steel Waler Universal SRU U120, l = 0.97 m
103874	30.900	Steel Waler Universal SRU U120, l = 1.22 m
103877	38.100	Steel Waler Universal SRU U120, l = 1.47 m
103886	44.700	Steel Waler Universal SRU U120, l = 1.72 m
103889	52.000	Steel Waler Universal SRU U120, l = 1.97 m
103898	58.600	Steel Waler Universal SRU U120, l = 2.22 m
103892	65.600	Steel Waler Universal SRU U120, l = 2.47 m
103929	72.000	Steel Waler Universal SRU U120, l = 2.72 m
103903	81.000	Steel Waler Universal SRU U120, l = 2.97 m
103906	92.600	Steel Waler Universal SRU U120, l = 3.47 m
103915	106.000	Steel Waler Universal SRU U120, l = 3.97 m
103918	119.000	Steel Waler Universal SRU U120, l = 4.47 m
103922	135.000	Steel Waler Universal SRU U120, l = 4.97 m
103925	146.000	Steel Waler Universal SRU U120, l = 5.47 m
103928	159.000	Steel Waler Universal SRU U120, l = 5.97 m

Universal Steel Waler Profile U120 used as waling for girder wall formwork and for diverse special applications. With adjustable spacers.

L

722
972
1222
1472
1722
1972
2222
2472
2722
2972
3472
3972
4472
4972
5472
5972

Note

Permissible load: see PERI Design Tables.

Technical Data

U120: $W_y = 121.4 \text{ cm}^3$, $I_y = 728 \text{ cm}^4$.

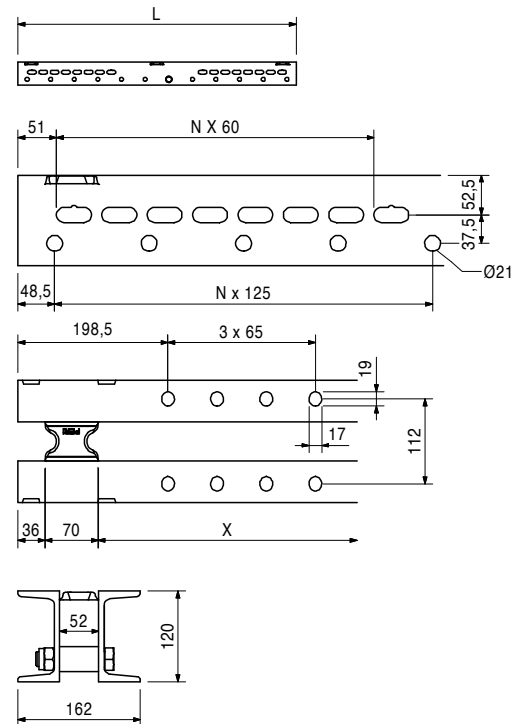
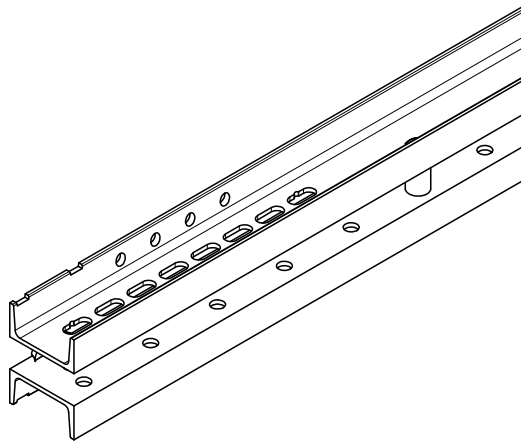

104027 7.610

Extension VARIO 24 U120

For assembly on Steel Waler SRU.

Complete with

- 4 pc. 710252 Bolt ISO 4017 M16 x 50-8.8, galv.
- 4 pc. 104024 Nut ISO 7040 M16-8, galv.
- 4 pc. 710880 Washer DIN 434 18, galv.

Technical Data

U120: $W_y = 121.4 \text{ cm}^3$, $I_y = 728 \text{ cm}^4$.

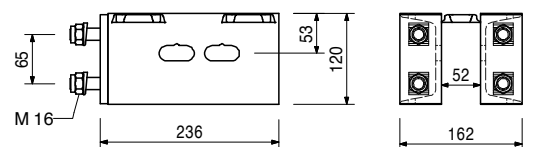
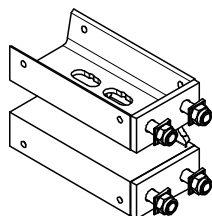

VST Heavy Duty Shoring Tower



Item no.	Weight kg		L
114166	78.200	Climbing Rails RCS	1480
109610	524.000	Climbing Rail RCS 148	9980
109472	393.000	Climbing Rail RCS 748	7480
109471	262.000	Climbing Rail RCS 498	4980
109470	182.000	Climbing Rail RCS 348	3480
109469	130.000	Climbing Rail RCS 248	2480
112102	156.000	Climbing Rail RCS 298	2980
112141	209.000	Climbing Rail RCS 398	3980

Steel profile for all-purpose use of climbing application or civil constructions. With Spacers M20-82 and M24-82.

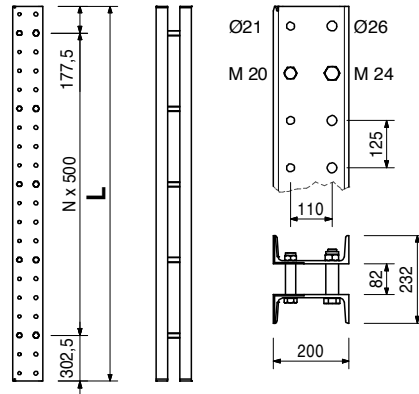

110022 0.491

Spacer M20-82

Spacer for Climbing Rails RCS.

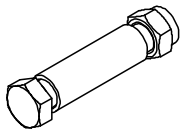

Complete with

1 pc. 104477 Bolt ISO 4014 M20 x 120-8.8, galv.
1 pc. 130341 Nut ISO 7042 M20-8, galv.

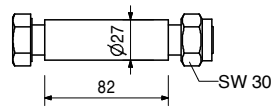

110023 0.910

Spacer M24-82

Spacer for Climbing Rails RCS.

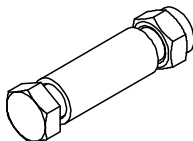

Complete with

1 pc. 109612 Bolt ISO 4014 M24 x 130-8.8, galv.
1 pc. 130342 Nut ISO 7042 M24-8, galv.

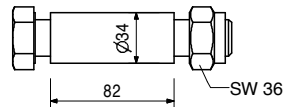

VST Heavy Duty Shoring Tower

Item no. Weight kg

Item no.	Weight kg	Heavy Duty Spindles SLS	A	min. L	max. L
111035	12.100	Heavy Duty Spindle SLS 40/80	344	400	800
101773	14.700	Heavy Duty Spindle SLS 80/140	746	800	1400
101774	18.200	Heavy Duty Spindle SLS 100/180	946	1000	1800
101776	24.700	Heavy Duty Spindle SLS 140/240	1346	1400	2400
101778	32.100	Heavy Duty Spindle SLS 200/300	1944	2000	3000
101779	38.300	Heavy Duty Spindle SLS 260/360	2544	2600	3600
109726	44.600	Heavy Duty Spindle SLS 320/420	3144	3200	4200
109785	50.800	Heavy Duty Spindle SLS 380/480	3744	3800	4800

Used as adjustable spindle for truss beams made of Steel Walers SRU and Climbing Rails RCS.

Note
Permissible load see PERI Design Tables.

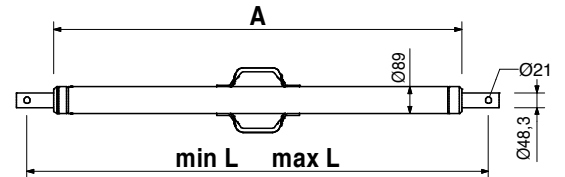
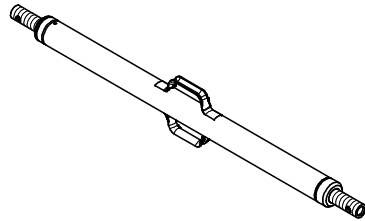

Accessories

104031	0.462	Fitting Pin Ø 21 x 120
018060	0.030	Cotter Pin 4/1, galv.
110477	3.990	Spindle Adapter SLS/RCS

110477	3.990	Spindle Adapter SLS/RCS For connecting the Heavy-Duty Spindle SLS to the Climbing Rail RCS.
--------	-------	---

Complete with
1 pc. 104031 Fitting Pin Ø 21 x 120
1 pc. 018060 Cotter Pin 4/1, galv.

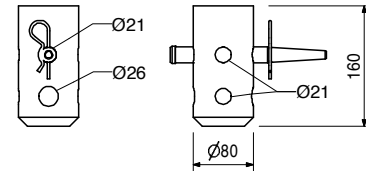
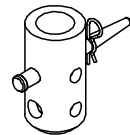

Accessories

104031	0.462	Fitting Pin Ø 21 x 120
018060	0.030	Cotter Pin 4/1, galv.
111567	0.729	Fitting Pin Ø 26 x 120
022230	0.033	Cotter Pin 5/1, galv.

104031	0.462	Fitting Pin Ø 21 x 120 For different connections.
--------	-------	---

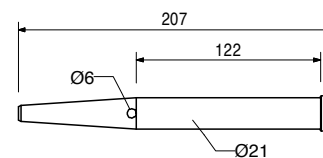
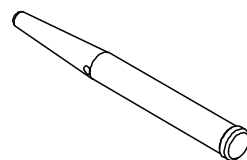

Accessories

018060	0.030	Cotter Pin 4/1, galv.
--------	-------	------------------------------

VST Heavy Duty Shoring Tower

Item no. Weight kg

018060 0.030 **Cotter Pin 4/1, galv.**

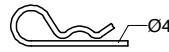

105416 0.360 **Bolts ISO 4014**
 113994 0.421 **Bolt ISO 4014 M24 x 80-8.8, galv.**
Bolt ISO 4014 M20 x 140-8.8, galv.

L

80
140

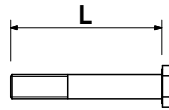
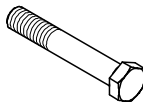

117452 0.360 **Bolts ISO 4014**
Bolt ISO 4014 M20 x 130-10.9
 114563 0.627 **Bolt ISO 4014 M24 x 140-10.9**

L

130
140

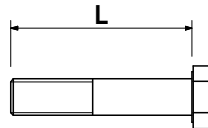
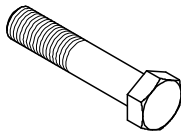

118256 0.020 **Cyl. Bolt ISO 4762 M20 x 150-8.8, galv.**

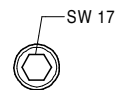
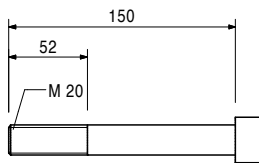
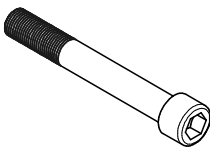

781053 0.065 **Nut ISO 7042 M20-8, galv.**
 Self-locking.

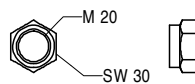

VST Heavy Duty Shoring Tower

Item no.	Weight kg	
----------	-----------	--

105032 0.070 **Nut ISO 7042 M24-8, galv.**
Self-locking.

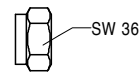

117492 0.109 **Sleeve VST, galv.**

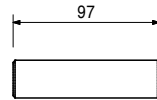
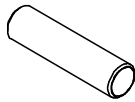

105400 0.330 **Pin Ø 20 x 140, galv.**
For different connections.

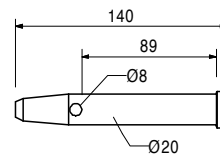
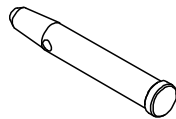

Accessories

018060 0.030 **Cotter Pin 4/1, galv.**

024250 0.331 **Wedge K, galv.**
For Coupling Compression Plate KDP, Wedge Head Piece SRZ/SRU and Waler Connector SB-A, B, C.

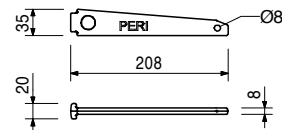

VST Heavy Duty Shoring Tower

Item no. Weight kg

		Standards UVR
102860	7.690	Standard UVR 150
100012	14.700	Standard UVR 300

L

1500
3000

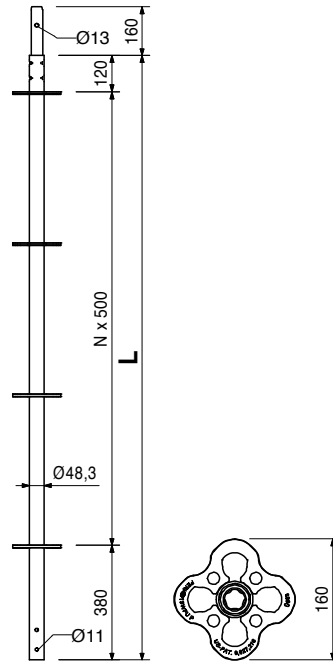
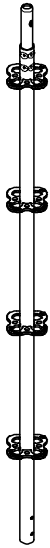

100021 4.690

Ledger UH 150

Note

As of 01.07.2009, only available as rentable item.

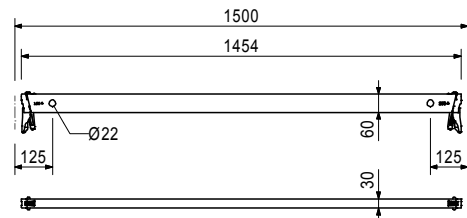
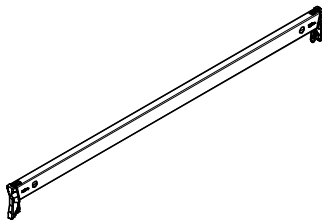

030030 1.440
030050 0.000

Tie Rod DW 15, spec. length
Tie Rod DW 15, spec. length
Cutting Cost Tie Rod DW 15, B 15

Note

Non-weldable! Take official approval into consideration!

Technical Data

Permissible tension force 90 kN.

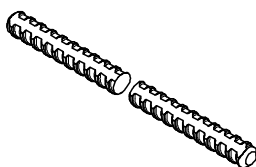

Item no.	Weight kg
030130	0.318

Cam Nut DW 15, galv.
For anchoring with Tie Rod DW 15 and B 15.

Technical Data
Permissible load 90 kN.

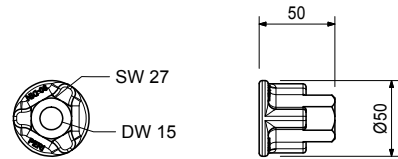
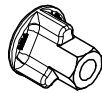

030370	1.660
--------	-------

Wingnut Pivot Plate DW 15, galv.
For anchoring with Tie Rod DW 15 and B 15. With pivoting captive nut. Maximum angle of tilting 8°.

Note
Wrench size SW 27.
Technical Data
Permissible load 90 kN.

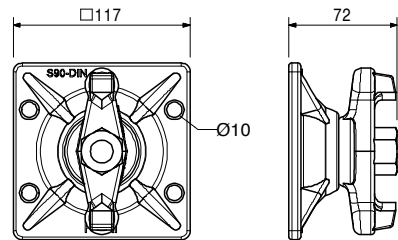
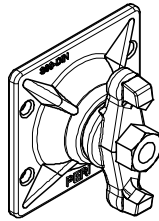

030340	4.480
030500	0.000

Tie Rod DW 26, spec. length
Tie Rod DW 26, spec. length
Cutting Cost Tie Rod DW 26

Note
Non-weldable! Take official approval into consideration!
Technical Data
Permissible tension force 250 kN.

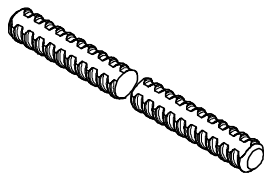

123825	1.130
--------	-------

Counterplate DW 26

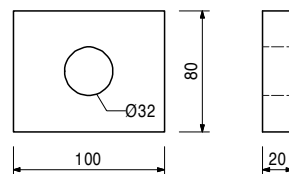
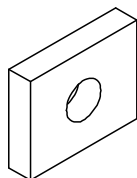

VST Heavy Duty Shoring Tower

Item no.	Weight kg
030970	0.800

Hex. Coupler DW 26 SW 46/80, weldable
For anchoring with Tie Rod DW 26.

Note
Weldable!
Technical Data
Permissible load 250 kN.

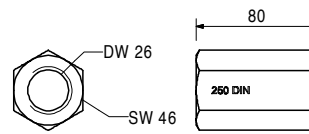
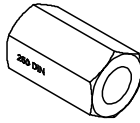

**The optimal System
for every Project and
every Requirement**



Wall Formwork



Column Formwork



Slab Formwork



Climbing Systems



Bridge Formwork



Tunnel Formwork



Shoring Systems



Construction Scaffold



Facade Scaffold



Industrial Scaffold



Access



Protection Scaffold



Safety Systems



System-Independent Accessories



Services



PERI GmbH
Formwork Scaffolding Engineering
 Rudolf-Diesel-Strasse 19
 89264 Weissenhorn
 Germany
 Tel. +49 (0)7309.950-0
 Fax +49 (0)7309.951-0
 info@peri.com
 www.peri.com