

CB 160 Climbing Formwork

Instructions for Assembly and Use – Standard Configuration – Version 1.9

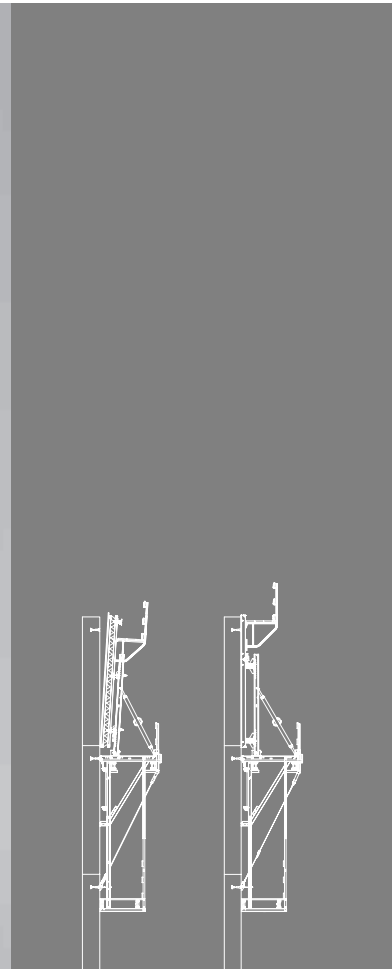
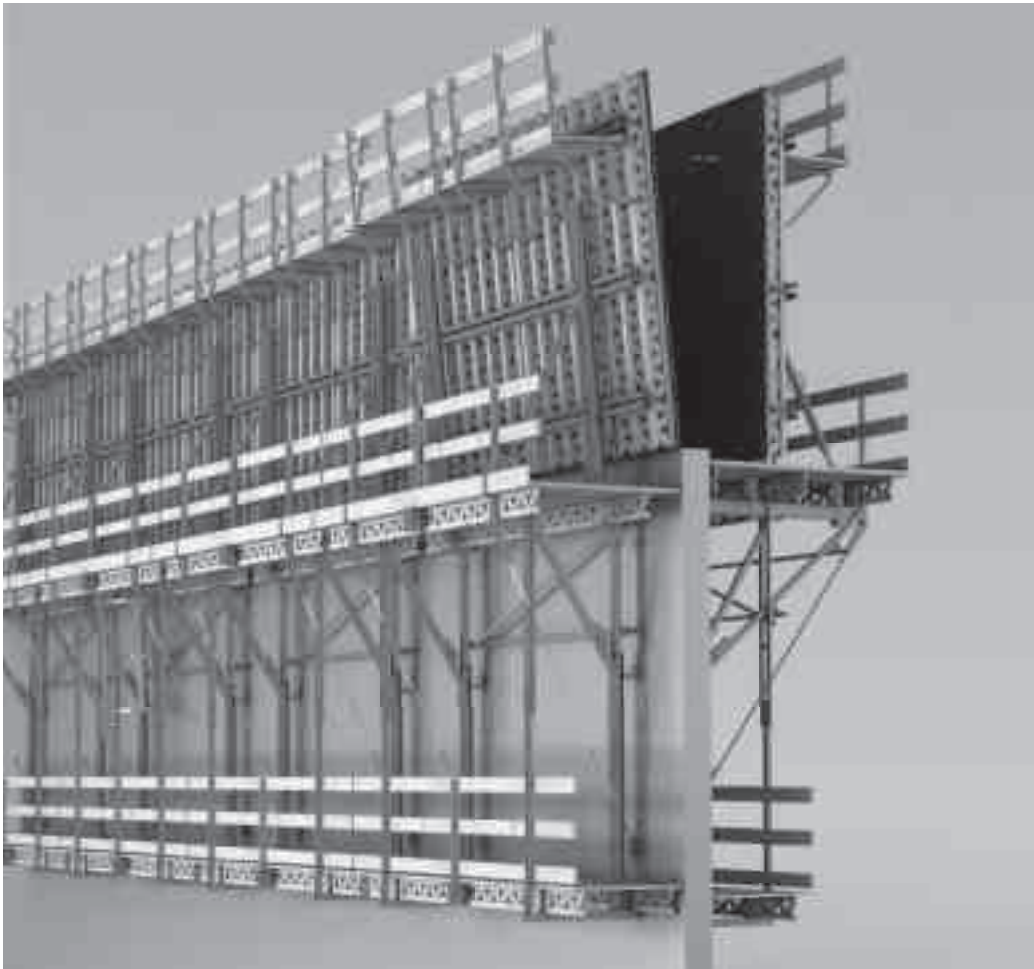

Main components, examples of design variants

Climbing Formwork CB 160 with VARIO GT 24 Girder Wall Formwork

- Concreting height 3.60 m
- Tension Anchor with Tie Rod DW 15 as wind bracing

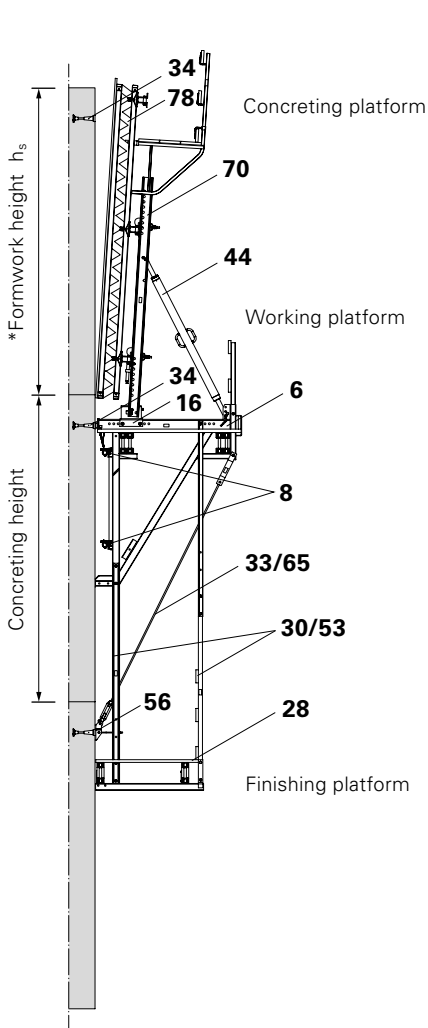

Climbing Formwork CB 160 with TRIO Panel Formwork

- Concreting height 3.60 m
- Tension Belt as wind bracing

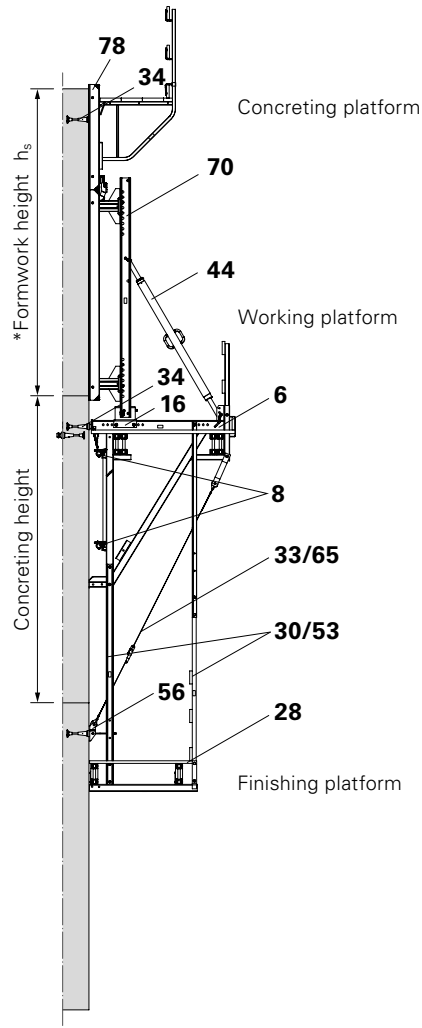

Anchoring to the building structure

Variant 1

- 36 Threaded Anchor Plate DW 15*
- 33 Tie Rod DW 15*, Z-12.4-70 or Tie Rod B15*, Z-12.5-82

$$L_1 = h - 8 \text{ cm}$$

34 Climbing Cone 2 M24/DW 15

- 45 Scaffold Mounting Ring M24, galv.
- 48 Bolt ISO 4014 M24 x 120-10.9

- 35 Spacer Tube DR 22* (optional)

$$L_2 = h - 18.5 \text{ cm (tolerance } 0 \text{ to } +5 \text{ mm)}$$

Anchoring depth h = variable, min. 18.5 cm.

* Not re-usable

When using the PVC Spacer Tube, the Tie Rod (5.5) can be re-used.

Variant 2

- 38 Threaded Anchor Plate DW 20*

37 Screw-On Cone 2 M24/DW 20

- 45 Scaffold Mounting Ring M24, galv.
- 48 Bolt ISO 4014 M24 x 120-10.9

Anchoring depth h = 15.5 cm.

* Not re-usable

- 6 Working platform with Climbing Bracket CB 160
- 16 Adjusting Unit CB 160
- 44 Adjustable Brace CB 164-224
- 70 Strongback CB 270 or CB 380
- 34 Anchoring and Leading Anchor
- 56 Bracing Shoe Wall CB M24

- 33/65 Wind bracing with Tension Belt or Tie Rod
- 28 Finishing platform with Platform Beam CB
- 30/53 Suspension of the finishing platform
- 78 VARIO GT 24 or TRIO Formwork with Concreting Scaffold
- 8 Bracing with Scaffold Tubes

*Formwork height = concreting height + formwork projection (max. 5.40 m)

Overview

Main components, examples of design variants	1
Key	2
Presentational reference	2

Introduction

Target groups	3
Additional technical documentation	3
Intended use	4
Instructions of Use	4
Cleaning and maintenance instructions	5

Safety instructions

Storage and transportation	6
Cross-system	7
System-specific	8

General

Operating states and loads	10
Load models	11
Standard work flow	12

Assembly

A1	Assembly of the CB 160 Platforms	
	Required resources	14
	Climbing Bracket CB 160	15
	Girders	16
	Adjusting Unit CB 160	18
	Guardrail Post CB	18
	Platform decking	19
	Guardrails	20
A2	Other assembly work	
	End Guardrail Posts	22
	Hatch cover	23
	Finishing platform	24
	Finishing tasks	25

Working

B1	Work on the construction site	
	Anchoring	26
	Mounting the Working Platform CB 160 to the first wall section	32
	Mounting the Finishing Platform CB 160	34
	Assembly of wind bracing	37
	Removal of the climbing cones	39
	Dismantling	39
	Ladder assembly	40
B2	Assembly of the formwork panels	
	VARIO GT 24 Panel	42
	Moving of VARIO GT 24 Panels	44
	TRIO/MAXIMO Panel with Adapter	
	TRIO-CB	46
	Exchanging the formwork panels	48
	TRIO/MAXIMO Panel with Formwork	
	Waler 150 CB	50
	Exchanging the formwork panels	54

B3	Operating the formwork	
	Utilisation of Adjusting Unit CB 160	56
	Alignment of the formwork	57
B4	Moving the units	
	Preparation	60
	Moving procedure	61
	Securing the moving unit	63

Planning

C1	Planning and work preparation for the platforms	
	Drawings and plans	64
	Identification markings	64
	Platform decking	65
	Guardrails and ladder safety cage	69
	Connecting the VARIO GT 24 Panel	70
	Connecting a TRIO/MAXIMO Panel by means of a Connector TRIO-CB	72
	Position of the Connector TRIO-CB	72
	Connecting a TRIO/MAXIMO Panel by means of a Formwork Waler 150 CB	74
	Moving the units	75
	Ladder access	76
	Weight of the moving unit	77
	Use on circular structures	78
	Use as working scaffold without formwork	79
	Load assumption	80
	Platform dimensioning	81
	Anchoring verification	82

Components

CB 160 Climbing Formwork	84
--------------------------	----

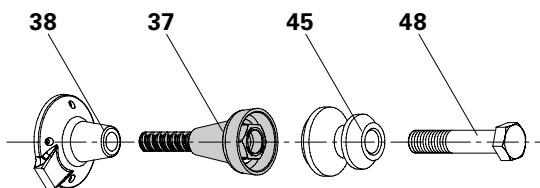
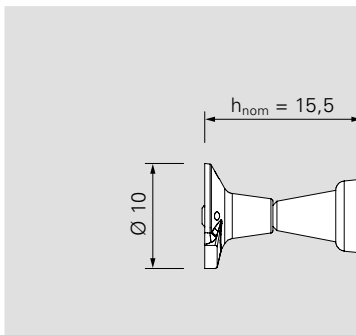
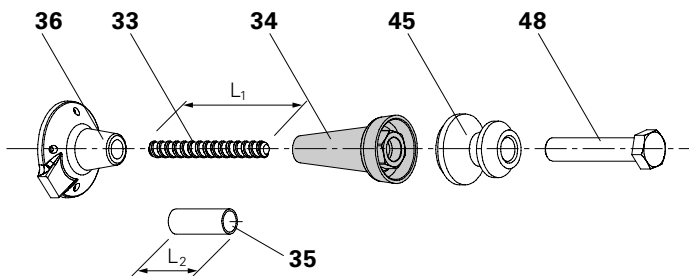
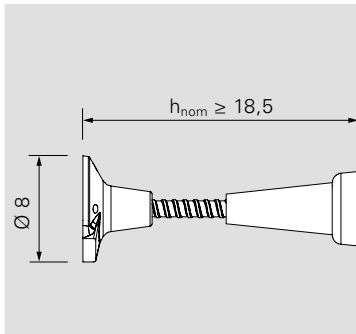

Key

Pictogram | Definition



Safety instructions



Note



Load-bearing point



Visual check



Tip

Dimension specifications

Dimensions are usually given in cm.

Other measurement units, e.g. mm, are shown in the illustrations.

Load details are usually given in kg. Other measurement units, e.g. t, are specified in the illustrations.

Conventions

- Instructions are numbered with:
1., 2., 3.
- The result of an instruction is shown by: →
- Position numbers are clearly provided for the individual components and are given in the drawing, e.g. **1**, in the text in brackets, for example (1).
- Multiple position numbers, i.e. alternative components, are represented with a slash, e.g. **1/2**.

Arrows



Arrow representing an action

Presentational reference

The illustration on the front cover of these instructions is understood to be a system representation only. The assembly steps presented in these Instructions for Assembly and Use are shown in the form of examples with only one component size. They are correspondingly valid for all component sizes contained in the standard configuration.

For a better understanding, detailed illustrations are partly incomplete. The safety installations which have possibly not been featured in these detailed drawings must nevertheless still be available.

Target groups

Contractors

These Instructions for Assembly and Use are designed for contractors who use PERI products either for

- assembling, modifying and dismantling, or use
- them e.g. for concreting or
- who have them used, e.g. for forming operations.

Construction site coordinator

The Safety and Health Coordinator*

- is appointed by the client,
- must identify potential hazards during the planning phase,
- determines measures that provide protection against risks,
- creates a safety and health plan,
- coordinates the protective measures for the contractor and site personnel so that they do not endanger each other,
- monitors compliance with the protective measures.

Competent personnel

Due to the specialist knowledge gained from professional training, work experience and recent professional activity, the competent person has a reliable understanding of safety-related issues and can correctly carry out inspections.

Depending on the complexity of the test to be undertaken, e.g. scope of testing, type of testing or the use of a certain measuring device, a range of specialist knowledge is necessary.

Qualified persons

PERI products may only be assembled, modified or dismantled by personnel who are suitably qualified to do so. For the work to be carried out, the qualified persons must have received instructions** which contain at least the following points:

- Explanation of the plan for the assembly, modification or dismantling of the formwork in an understandable form and language.
- Description of measures in order to safely assemble, modify or dismantle the scaffolding.
- Designation of the preventive measures to avoid the risk of persons and objects falling.

- Designation of the safety precautions in the event of changing weather conditions which could adversely affect the safety of the PERI products concerned as well as the personnel.
- Details regarding the permissible loads.
- Description of any other risks that are associated with the assembly, modification or dismantling procedures.



- **In other countries, ensure that the relevant national guidelines and regulations in the respective current version are complied with!**
- **If no country-specific regulations are available, it is recommended to proceed according to German rules and regulations.**

* Valid in Germany: Regulations for Occupational Health and Safety on Construction Sites 30 (RAB 30).

** Instructions are given by the contractor himself or a competent person selected by him.

Additional technical documentation

- Design Information for the Climbing Formwork CB 160
- Instructions for Assembly and Use
 - VARIO GT 24 Girder Wall Formwork
 - TRIO Panel Formwork
 - MAXIMO Panel Formwork
- Instructions for Use
 - Crane Splice 24
 - Lifting Hook MAXIMO 1.5 t
 - Concrete Cones
 - Lifting Beam 10 t
 - Platform Connection CB 160
- Design Tables 2015 – Formwork and Shoring

Intended use

Product description

PERI products have been designed for exclusive use in the industrial and commercial sectors by qualified personnel only.

Climbing Formwork CB 160 is normally used as shoring in order to support anchored wall formwork in accordance with EN 12812. The formwork is firmly connected to the scaffolding and is moved as a single unit suspended on a crane. The system can also be used as working scaffold only. The working platform for operating the formwork consists of one platform beam and two fixed climbing brackets. These transfer the loads deriving from the dead weight, live loads and prevailing wind loads via the anchorage and bottom pressure point into the structure.

Features

The working platform can be supplemented with:

- Adjusting Unit, Strongback and Adjustable Brace for accommodating the VARIO, TRIO and MAXIMO formwork systems.
- a height-adjustable finishing platform complete with access ladder which is attached to posts.
- end-to-end guardrails on the working and finishing platforms in accordance with EN 12811.
- a tension anchor which prevents tipping inwards.

Technical data

- Width of bracket: 1.60 m.
- Static height: 1.80 m.
- Max. formwork height 5.40 m.
- The formwork can be inclined by turning the spindle.

Instructions for Use

The use in a way not intended, deviating from the standard configuration or the intended use according to the Instructions for Assembly and Use, represents a misapplication with a potential safety risk, e.g. risk of falling.

Only PERI original components may be used. The use of other products and spare parts is not allowed.

Changes to PERI components are not permitted.

Cleaning and maintenance instructions

In order to maintain the value and operational readiness of the formwork materials over the long term, clean the panels after each use.

Some repair work may also be inevitable due to the tough working conditions. The following points should help to keep cleaning and maintenance costs as low as possible.

Spray the formwork on both sides with concrete release agent before each use; this allows easier and faster cleaning of the formwork. Spray the concrete release agent very thinly and evenly!

Spray the rear side of the formwork with water immediately after concreting; this avoids any time-consuming and costly cleaning operations.

When used continuously, spray the panel formlining with concrete release agent immediately after striking; then clean by means of a scraper, brush or rubber lip scraper. Important: do not clean formlining made of plywood with high-pressure equipment; this could result in the formlining being damaged.

Fix box-outs and mounting parts with double-headed nails; as a result, the nails can easily be removed later, and damage to the formlining is largely avoided.

Close all unused anchor holes with plugs; this eliminates any subsequent cleaning or repair work. Anchor holes accidentally blocked with concrete are freed by means of a steel pin from the formlining side.

When placing bundles of reinforcement bars or other heavy objects on horizontally-stored formwork elements, suitable support, e.g. square timbers, is to be used; as a result, impressions and damage to the formlining are largely avoided.

Internal concrete vibrators should be fitted, if possible, with rubber caps; as a result, any damage to the formlining is reduced if the vibrator is accidentally "inserted" between the reinforcement and formlining.

Never clean powder-coated components, e.g. elements and accessories, with a steel brush or hard metal scraper; this ensures that the powder-coating remains intact.

Use spacers for reinforcement with large-sized supports or extensive areas of support; this largely avoids impressions being formed in the formlining when under load.

Mechanical components, e.g. spindles or gear mechanisms, must be cleaned of dirt or concrete residue before and after use, and then greased with a suitable lubricant.

Provide suitable support for the components during cleaning so that no unintentional change in their position is possible.

Do not clean components suspended on a crane.

Storage and transportation

Store and transport components ensuring that no unintentional change in their position is possible. Detach lifting accessories and slings from the lowered components only if they are in a stable position and no unintentional change is possible.

Do not drop the components.

Use PERI lifting accessories and slings as well as only those load-bearing points provided on the component.

During the moving procedure

- ensure that components are picked up and set down so that unintentional falling over, falling apart, sliding, falling down or rolling is avoided.
- no persons are allowed to remain under the suspended load.
- remove or secure any loose components.

Always guide pre-assembled scaffolding bays, scaffolding units or scaffolding sections with ropes when moving them by crane.

The access areas on the jobsite must be free of obstacles and tripping hazards as well as being slip-resistant.

For transportation, the surface used must have sufficient load-bearing capacity.

Use original PERI storage and transport systems, e.g. crate pallets, pallets or stacking devices.

Cross-system

General

The contractor must ensure that the Instructions for Assembly and Use supplied by PERI are available at all times and understood by the site personnel.

These Instructions for Assembly and Use can be used as the basis for creating a risk assessment. The risk assessment is compiled by the contractor. These Instructions for Assembly and Use do not replace the risk assessment!

Always take into consideration and comply with the safety instructions and permissible loads.

For the application and inspection of PERI products, the current safety regulations and guidelines must be observed in the respective countries where they are being used.

Materials and working areas are to be inspected on a regular basis especially before each use and assembly for:

- signs of damage,
- stability and
- function.

Damaged components must be exchanged immediately on site and may no longer be used.

The contractor must ensure that appropriate fire protection measures are in place.

Safety components are to be removed only when they are no longer required.

Components provided by the contractor must conform with the characteristics required in these Instructions for Assembly and Use as well as with all valid construction guidelines and standards. In particular, the following applies if nothing else is specified:

- timber components: Strength Class C24 for Solid Wood according to EN 338.
- scaffold tubes: galvanised steel tubes with minimum dimensions of $\varnothing 48.3 \times 3.2$ mm according to EN 12811-1:2003 4.2.1.2.
- scaffold tube couplings according to EN 74.

Deviations from the standard configuration are only permitted after a further risk assessment has been carried out by the contractor. On the basis of this risk assessment, appropriate measures for working and operational safety as well as stability are to be determined.

Corresponding proof of stability can be provided by PERI on request if the risk assessment and resulting measures to be implemented are made available.

Before and after exceptional occurrences that may have an adverse effect regarding the safety of the PERI product, the contractor must immediately

- create another risk assessment with appropriate measures for ensuring the stability of the formwork system being carried out based on the results,
- and arrange for an extraordinary inspection by a competent person. The aim of this inspection is to identify and rectify any damage in good time in order to guarantee the safe use of the climbing system.

Exceptional occurrences can include:

- accidents, fire, overloading,
- longer periods of non-use,
- natural events, e.g. heavy rainfall, icing, heavy snowfall, storms or earthquakes.

Assembly, modification and dismantling work

Assembly, modification or dismantling of PERI products may only be carried out by qualified persons under the supervision of a competent person. The qualified personnel must have received appropriate training for the work to be carried out with regard to specific risks and dangers.

On the basis of the risk assessment and Instructions for Assembly and Use, the contractor must create installation instructions in order to ensure safe assembly, modification and dismantling of the PERI product.

The contractor must ensure that the personal protective equipment required for the assembly, modification or dismantling of the PERI product, e.g.

- safety helmet,
 - safety shoes,
 - safety gloves,
 - safety glasses,
- is available and used as intended.

If personal protective equipment against falling (PPE) is required or specified in local regulations, the contractor must determine appropriate attachment points on the basis of the risk assessment.

The personal protective equipment against falling to be used is determined by the contractor.

The contractor must

- provide safe working areas for site personnel which are to be reached through the provision of safe access ways. Areas of risk must be cordoned off and clearly marked.
- ensure the stability during all stages of construction, in particular during assembly, modification and dismantling of the formwork.
- ensure and prove that all loads can be safely transferred.

Utilisation

Every contractor who uses the PERI product or allows parts of the product to be used, has the responsibility for ensuring that the equipment is in good condition.

If the PERI product is used successively or at the same time by several contractors, the health and safety coordinator must point out any possible mutual hazards and all work must be then coordinated.

System-specific

Retract components only when the concrete has sufficiently hardened and the person in charge has given the go-ahead for striking to take place.

Anchoring is to take place only if the anchorage has sufficient concrete strength.

Inspection of the anchoring and associated components must be carried out by the contractor.

As a result of the moving procedure, falling edges arise between the platforms. Corresponding areas are to be secured.

Site personnel, construction materials or tools may not be transported with the crane during moving operations. Exceptions to this can be determined through the operational working and assembly instructions.

During operating conditions, working areas at great heights are always to be secured against falling objects through the use of suitable measures.

Enclosure of the platform or mounting of additional surfaces which are exposed to the influences of the wind changes the stability and must therefore be checked. If necessary, additional measures must be implemented.

Hatches and openings on accessible working areas must be kept closed during working operations.

Use a guide rope to ensure that assembly units suspended from the crane are fully under control when being moved.

Assembly work

The contractor must ensure that the user has the appropriate and sufficient number of tools, lifting equipment and slings, suitable and sufficient space for assembly and storage as well as adequate crane capacity at his disposal.

There is always the possibility that unforeseen risks arise during assembly work. Assess the degree of risk in each individual case and, if necessary, take measures to prevent or at least minimize the risk.

If anti-fall protection cannot be used or has to be removed due to operational reasons, safety equipment must be installed in its place in order to prevent or arrest falls from any height.

If the use of fall arrest equipment is deemed to be inappropriate, personal protection equipment (PPE) can be used if suitable fixing points are available.

Maintenance and repairs

Components of the climbing formwork are to be inspected before each use to ensure that they are in perfect condition and function correctly.

Only materials in good working condition may be used.

The platforms are to be inspected for signs of damage at regular intervals by authorised personnel.

Remove loose concrete residue.

Dirt which affects the functionality is to be removed immediately.

Damaged components are to be inspected, removed and replaced.

In case of overload or damage, stop work on and under the platforms, determine the cause, set down and replace damaged components.

If the maximum permissible wind speed has been exceeded, temperatures are outside the scope of application or after any extraordinary event has taken place such as a fire or earthquake, the functionality and load-bearing capacity of all safety components as well as the supporting structure are to be checked.

Access

Safe access to all working areas must be guaranteed at all times.

Preferred options are walkways, stairs, stair towers or site lifts. Ladders are suitable for use as access ways in exceptional cases only.

Ladders must not be connected to each other for more than two levels and should be offset against one another.

Ladders must be secured on the outer side by means of appropriate anti-fall equipment such as ladder safety cages or safety nets.

Leading edges on hatches and openings in accessible areas must be secured.

In the case of danger, it must be ensured that working areas can be vacated via emergency escape routes or rescue equipment.

It must also be ensured that at least one emergency escape route or piece of rescue equipment can still be used if the power supply fails.

Determine and apply all appropriate measures.

In case the access hatches are blocked when retracting the formwork, ensure that site personnel can still use the emergency escape route.

During the entire moving procedure, ensure that site personnel can still use the emergency escape route.

The platforms are to be inspected for signs of damage at regular intervals by authorised personnel. Dirt which affect the functionality is to be removed immediately.

Protection against falling components

Work activities may not be carried out simultaneously on areas positioned on top of each other if the lower working areas are not protected against falling objects.

Avoid positioning working areas and access points in areas of risk.

If this is not possible due to work procedures, suitable protective measures must be available to provide protection against falling objects.

Safety nets (mesh size ≤ 2 cm) and planking are considered to be suitable means and are to be installed very closely (distance ≤ 5 cm) to the building.

Concrete residue and other soiling that could impair or cause the function to fail must be removed. Platforms are to be kept clean at all times.

Secure all pins with cotter pins and all bolts with nuts.

Climbing procedure

Take into consideration the permissible wind speed limit for the climbing procedure.

As a result of the moving procedure, leading edges are formed between the platforms as well as at building openings. If work is carried out in this area, site personnel must be secured against falling (e.g. PPE).

Secure all resulting shearing edges by means of covers. Cordon off areas of risk during the climbing procedure.

In case of a malfunction, lower the platform to the next possible position, personnel are to leave the climbing unit in a safe and secure manner and an authorized person is to be notified immediately.

Operational status (Working)

- Cleaning of formwork, reinforcing of walls, closing and striking of formwork, anchor installation and dismantling, inspection and maintenance.
- Platforms are freely accessible for the work to be carried out.
- Formwork is in the concreting position or retracted on the formwork carriage.
- Max. wind speed ≤ 72 km/h (wind pressure $q \leq 0.25$ kN/m²).
- Loads are evenly distributed. Single-sided loads on cantilevered platform areas are only allowed if an appropriate fixation against lift-off is fitted to the bracket positioned opposite.

Non-operational status (Storm)

- During longer work breaks or storm warnings with wind speeds ≥ 72 km/h.
- Bring the formwork into concreting position.
- Accessing the platforms during storm conditions is forbidden.
- Materials remaining on the platforms must be secured.
- Max. resulting wind speed (wind flow pressure) for storms depends on the utilisation height, wind zone and terrain category in accordance with EC 1.
- For storm warnings with higher wind speeds than assumed, an authorized person is to be informed and all enclosure netting and tarpaulin removed. The climbing unit can be climbed back to the previous concreting section if instructed to do so. Remove materials and equipment from the platforms.

Climbing status

- Move the climbing unit with the crane.
- The formwork is retracted or inclined to the rear.
- Non-intended loads on the platform must be removed.
- During the climbing procedure, site personnel are not allowed to remain on the platform.

Concreting status (Working)

- Concrete the casting segment.
- Concreting platform is freely accessible for the work to be carried out.
- Intermediate platform: only interim access for reaching the concreting platform, no working loads.
- Working platform and finishing platform: only access – no additional loads.
- Formwork in concreting position.
- Max. wind speed ≤ 72 km/h (wind pressure $q \leq 0.25$ kN/m²).



- Loads are evenly distributed. One-sided loading of cantilevered platform areas is not permitted.
- Storm: reduced load on the working platform for materials left behind.



Working: if more platforms are loaded, only one level can be fully loaded; other platform levels directly above and below only 50 %.

Working position

The area-related live loads correspond to EN 12811.

Presentation of the CB 160 as primary formwork compared to Climbing Formwork CB 240.

Concreting position

The area-related live loads correspond to EN 12811.

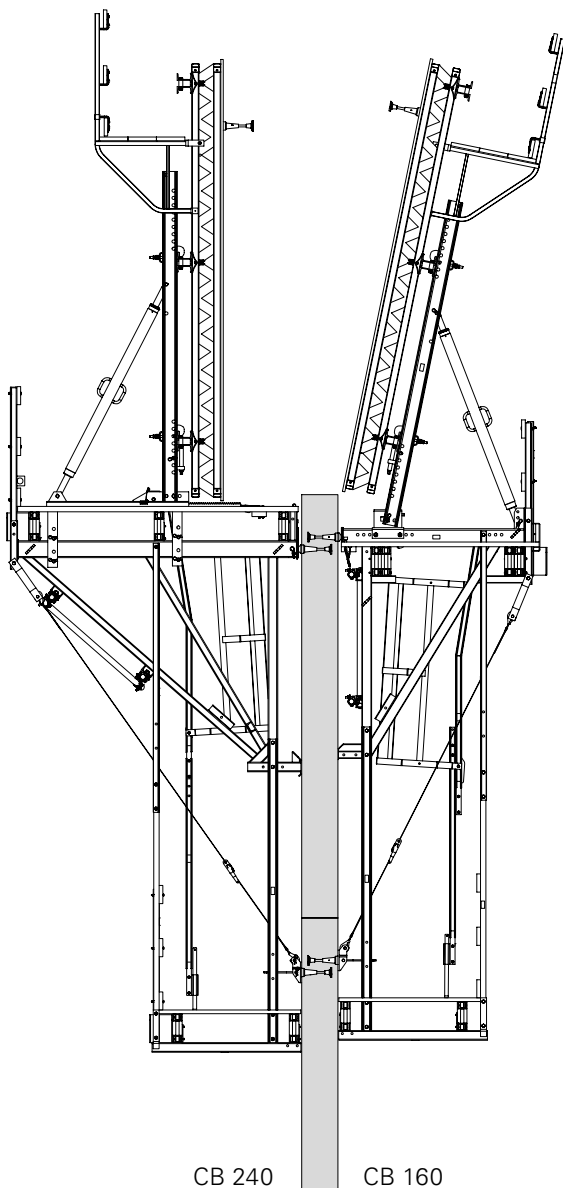

**Concreting Platform
CB 160**
150 kg/m²
Load Class 2

**Working Platform
CB 160**
200 kg/m²
Load Class 3

**Finishing Platform
CB 160**
75 kg/m²
Load Class 1

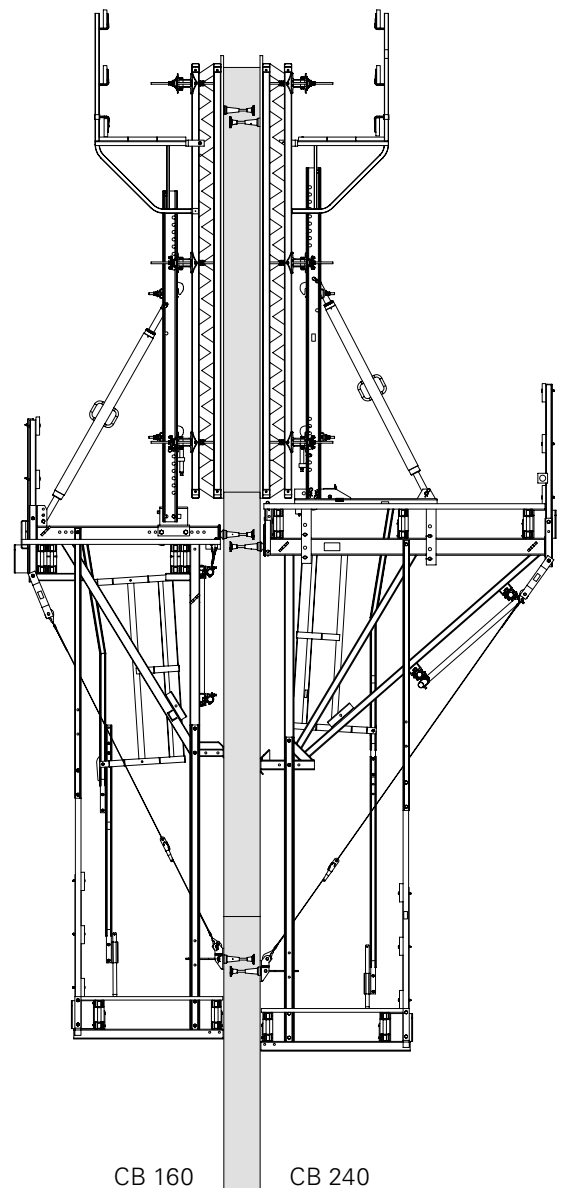

Presentation of Climbing Formwork CB 160 as primary formwork compared to Climbing Formwork CB 240 with Carriage

Preparation

1. Assemble wall formwork.
2. Assemble platforms.
3. Assemble finishing platform.



Moving procedure:

- Do not transport persons!
- Do not transport any loose parts or other loads!

Initial use

1. Position wall formwork for first wall section.
2. Add reinforcement to first wall section.
3. Mount leading anchor and close formwork.
4. Place formwork anchor.
5. Pour first wall section.
6. Release advancing bolts and strike.
7. Mount scaffold mounting rings.
8. Attach climbing platforms.
9. Mount wind bracing if required.
10. Place formwork on climbing platform and secure.
11. Clean formwork and adjust if necessary.
12. Reinforce second wall section.
13. Mount leading anchor and close formwork.
14. Place formwork anchor.
15. Pour second wall section.
16. Release advancing bolts and retract formwork.
17. Mount scaffold mounting rings.

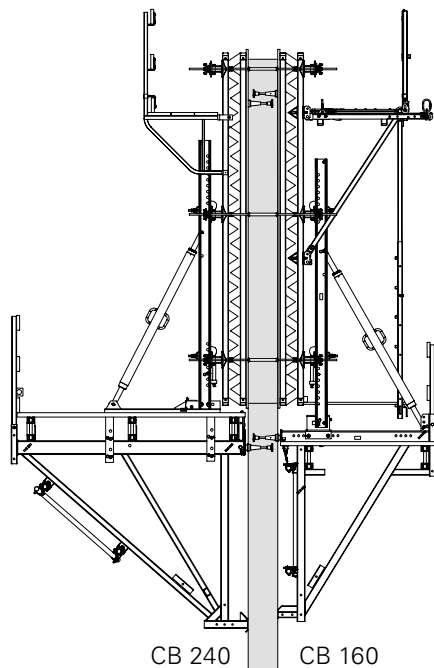
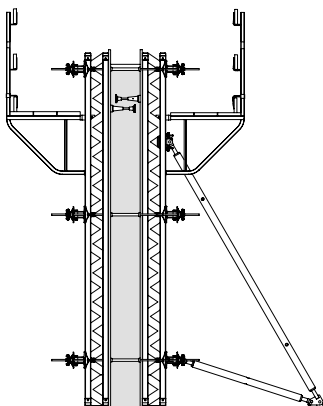

CB 240 CB 160

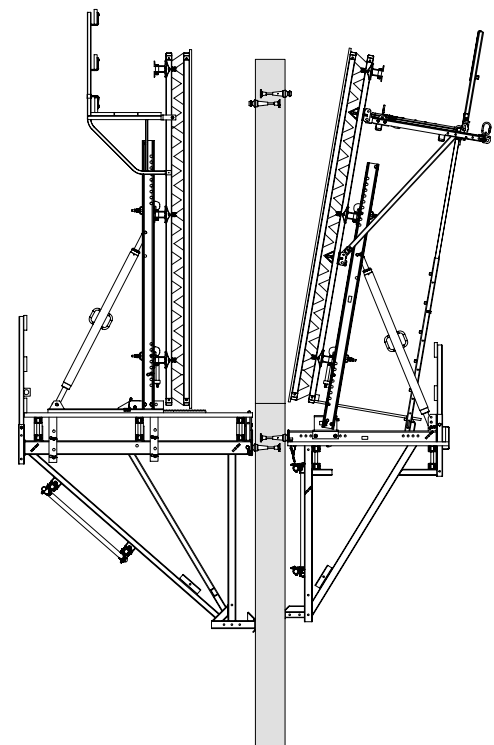

- 18. Attach finishing platform.
- 19. Move climbing scaffold to second wall section.
- 20. Bolt on finishing platform and attach guardrails.
- 21. If necessary, mount ladder.

Standard cycle

- 22. Mount wind bracing if required.
- 23. Clean formwork and adjust.
- 24. Reinforce wall.
- 25. Mount leading anchor and close formwork.
- 26. Place formwork anchor.
- 27. Pour wall section.

- 28. Release advancing bolts and retract formwork.
- 29. Mount scaffold mounting rings.
- 30. Remove climbing cones from previous wall section.
- 31. Move climbing formwork to next wall section.

Continuing with standard cycle

- 32. Dismantle the climbing formwork.

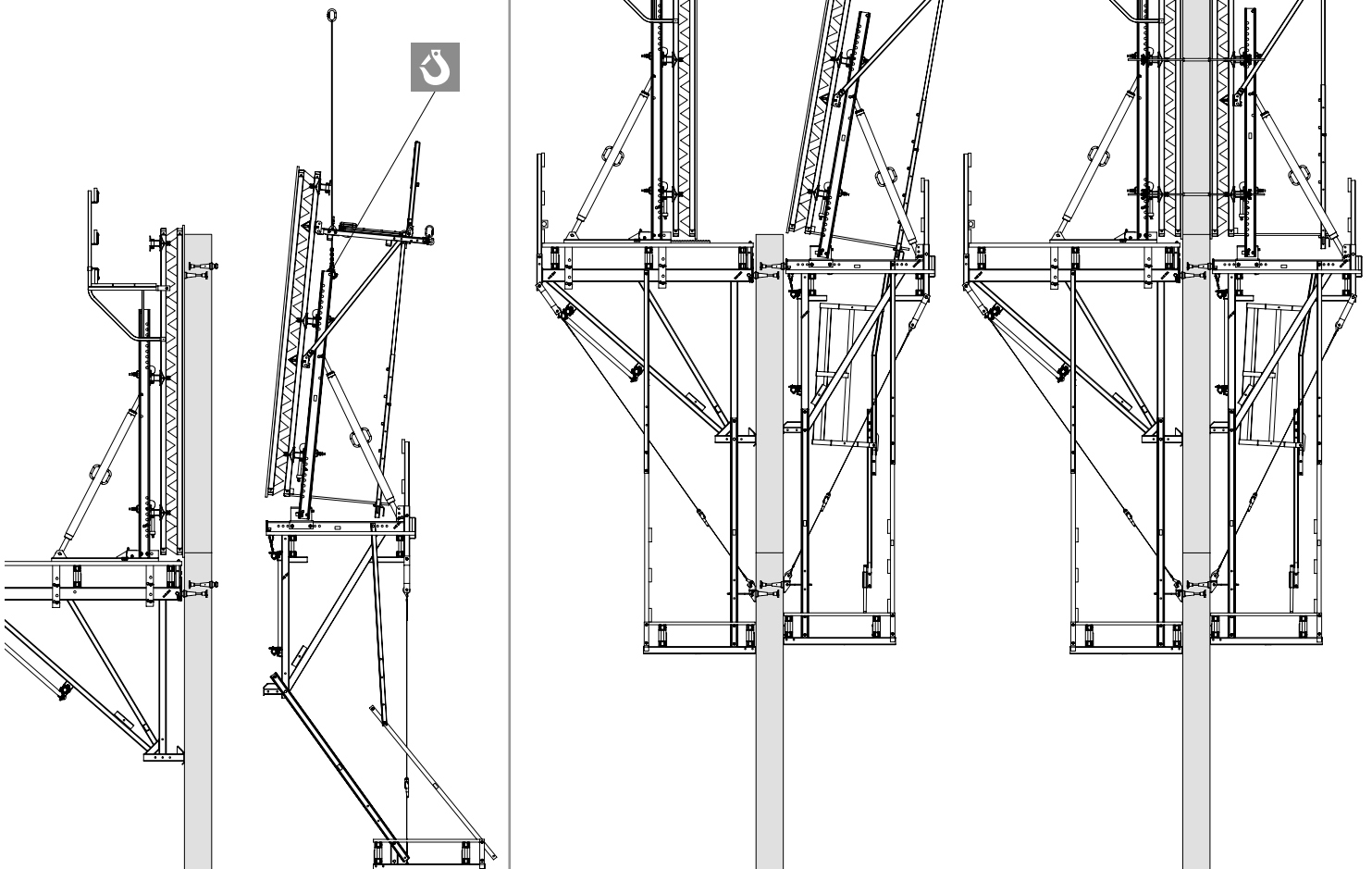

Required resources

Equipment and tools

Hammer, wire pins, plumb line, 4 screw clamps with 300 mm clamping length, circular saw, electric drill, HSS drill \varnothing 6 mm, \varnothing 8 mm, min. L = 180 mm.

072180 Ratchet Wrench 1/2"

102784 Socket SW 24 – 1/2"

Wrench SW 24

029620 Socket SW 19 – 1/2"

Wrench SW 19

072170 Socket SW 13 – 1/2"

072150 Electric Power Wrench (recommended)

072080 Electric Screw Driver

072090 Bit Holder

072120 Magnetic Holder

072140 Bit Points TX 30

031480 Socket Wrench SW 36

027212 Allen Key SW 14

031080 Drill Bit \varnothing 25 mm

Assembly surface

Width: approx. 3.50 m.

Length: maximum platform width + 2.0 m.

Attach stop bars and support.

(Fig. A1.01)

Aids

– Locating Block (1) 12 plywood blocks 21 x 80 x 80 mm.

– Support h = approx. 24 cm, e.g.

GT 24 (2) L = max. bracket spacing + 1.0 m.

– Stop bars 1 plank 40 x 120 mm (3) 1 plank 80 x 80 mm L = max. bracket spacing + 1.0 m.

– Gauge for bracket spacing C 1 plank 40 x 120 mm (4) L = bracket spacing + max. 1.0 m formlining blocks (1) (Fig. A1.02)

– Diagonal bracing for securing bracket 1 plank 40 x 120 mm, L = 2.0 m (5) (Fig. A1.03)

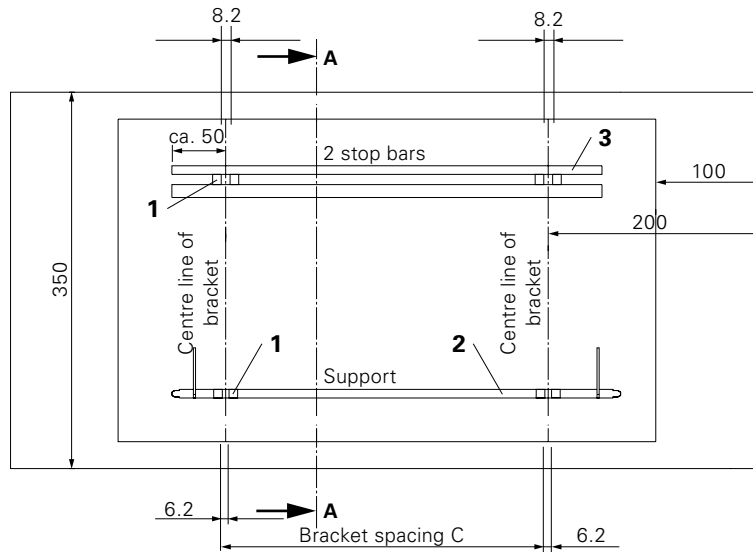

Fig. A1.01

Section A-A

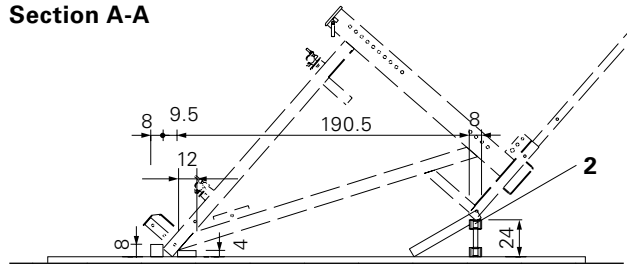

Fig. A1.01a

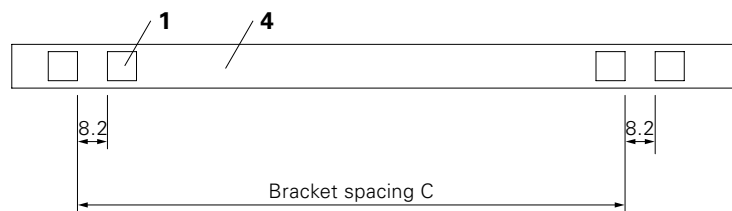

Fig. A1.02

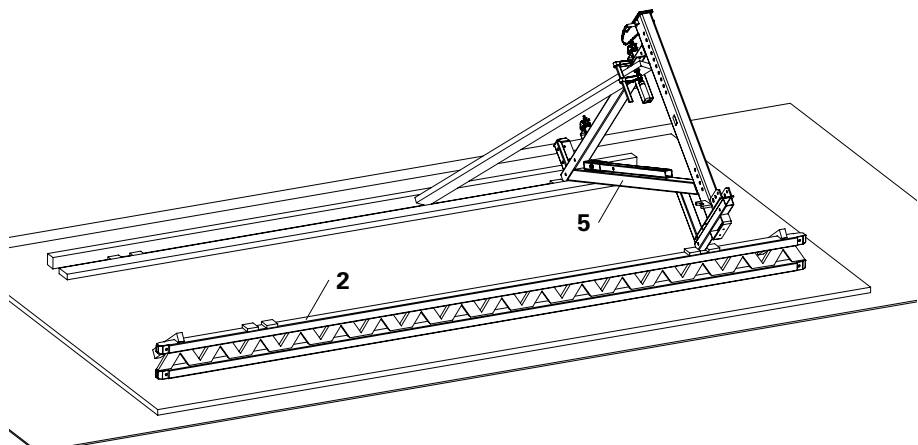

Fig. A1.03



Are the stop bars and support mounted in parallel?

Climbing Bracket CB 160

Assembly

1. Check centre-to-centre spacing regarding the planned measurement, or measure spacing of climbing cones already cast in concrete.
2. Adjust centre-to-centre spacing of brackets to Lattice Girders GT 24 (2). (Fig. A1.04)
3. Fix locating blocks (1). (Fig. A1.05)
(For spacings: see Fig. A1.02)
4. Lift first Climbing Bracket CB 160 (6) vertically into the stops and then align.
5. Fix with diagonal bracing (5). (Fig. A1.06)
6. Lift in second bracket and align bracket spacing using gauge (4).
7. Fix gauge using screw clamps. Check bracket spacing. (Fig. A1.06)
8. Fix two Scaffold Tubes Steel $\varnothing 48.3 \times 3.2$ (8a) to Screw-On Couplings AK 48 (7) in a parallel position to the support.
9. Brace with one diagonally-positioned Scaffold Tube Steel $\varnothing 48.3 \times 3.2$ (8b) and two Swivel Couplings DK 48/48 (9). (Fig. A1.07)



Fig. A1.04



Fig. A1.05

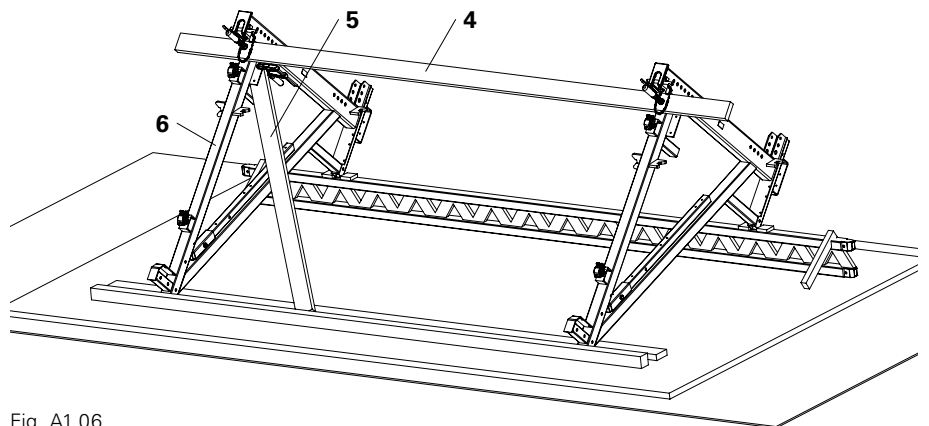

Fig. A1.06

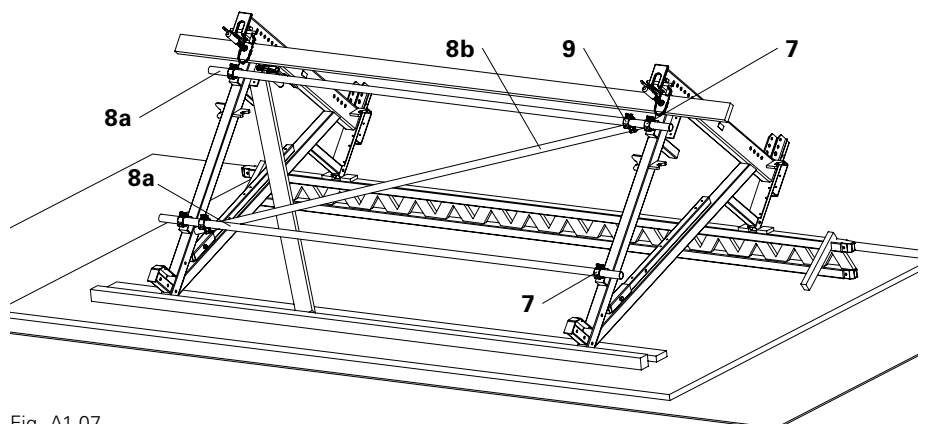

Fig. A1.07



The bracket axes form a right angle to the stops and support.



The scaffold tubes should project at least 100 mm over the couplings.

The brackets are now aligned.

Girders



- When the cantilevers are loaded, lifting forces can be created on the bracket positioned opposite.
- Secure the girders against lifting.

Assembly

1. Fix Lattice Girder GT 24 (2) by means of screw clamps.
 2. Pre-drill Lattice Girder GT 24 (Ø 8) and fix to the mounting plates with 2x F. H. Bolts DIN 603 M8 x 100, MU (20).
- (Fig. A1.08)

Alternatively:

- Hex. Wood Screws DIN 571 8 x 80 (86) or M8 x 180 MU (85) for double girders.
- (Fig. A1.09 + A1.12)



- If no girders have been included in the planning, these can be determined from C1 Platform decking.
- Pre-drill girders when using F. H. Bolts.
- Use F. H. Bolts for longer girder cantilevers.
- Timbers must be fixed accordingly.
- In order to avoid the risk of lifting in the case of large cantilevers, timber blocks must be placed on the opposite side between the bracket cross-beams and girders. Fix to the girders by means of wood screws.

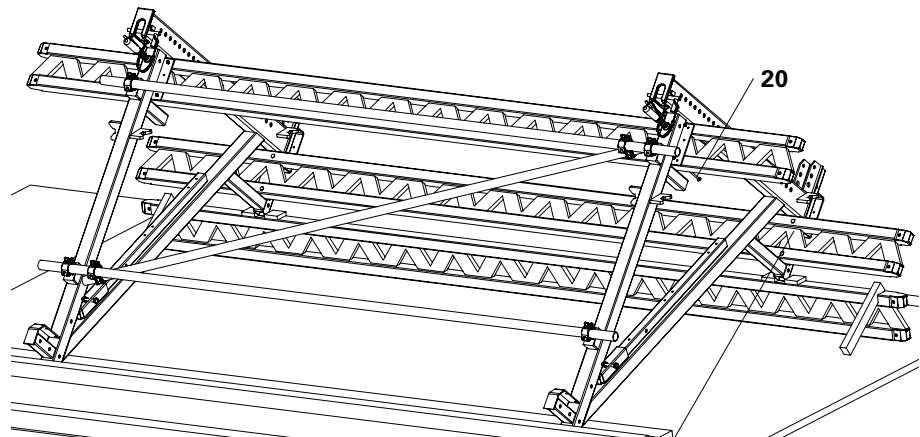

Fig. A1.08

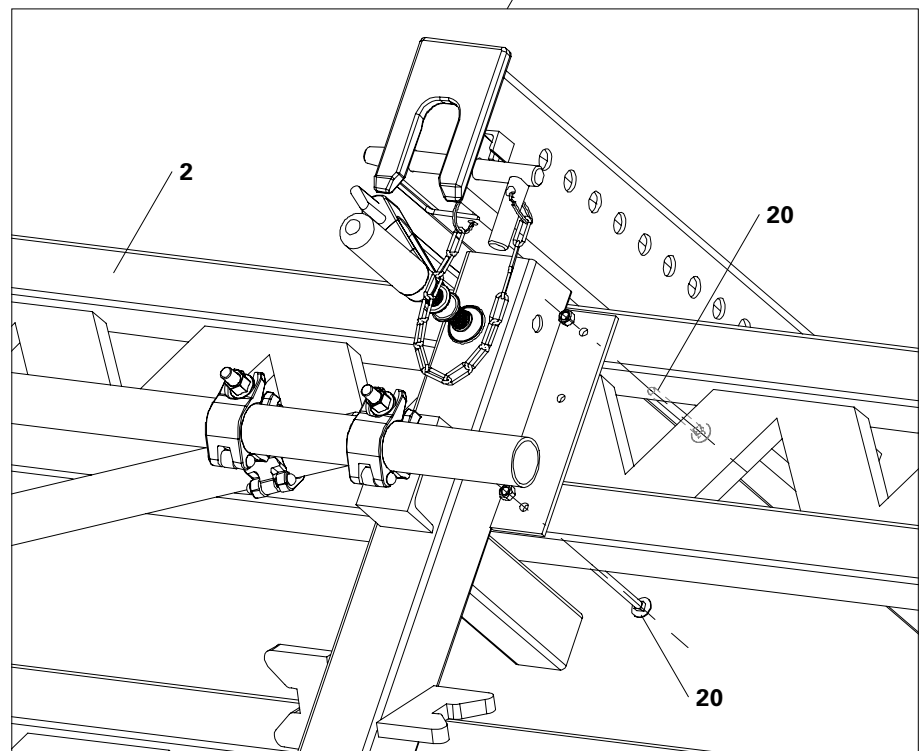

Fig. A1.08a

Single girder position

- F. H. Bolt DIN 603 M8 x 100, MU (20)
- Lattice Girder GT 24 (2) (Fig. A1.09)
- Timber 8 x 16 (13) (Fig. A1.10)

GT 24 Girder

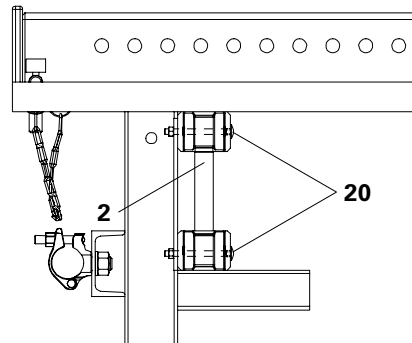

Fig. A1.09

Timber

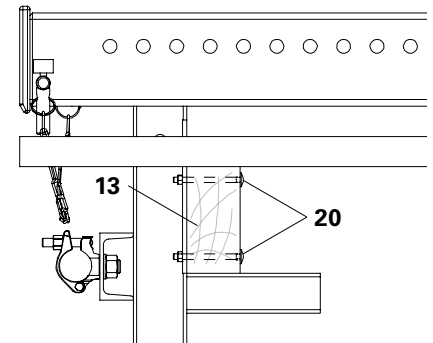

Fig. A1.10

Double girder position

- F. H. Bolt DIN 603 M8 x 180, MU (85)
- 2x Lattice Girder GT 24 (2) (Fig. A1.11)
- 2x Timbers 8 x 16 (13) or 1x 16 x 16 (15) (Fig. A1.12)

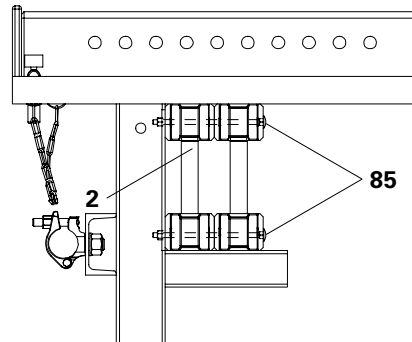

Fig. A1.11

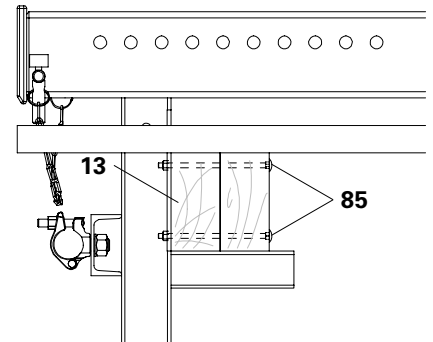

Fig. A1.12

Assembly as working scaffold



Follow Instructions for Use for the Platform Connection CB 160.



For operating the securing bolts from above, a spacing of $x \geq 23$ cm is required.

1. Bolt on two Platform Connections CB 160 (14) per bracket.
2. For supporting the decking, fix Timbers 16 x 16 (15) with F. H. Bolts DIN 603 M8 x 180, MU (85).

Alternatively:

Hex. Wood Screw DIN 571 8 x 80.

(Fig. A1.13)

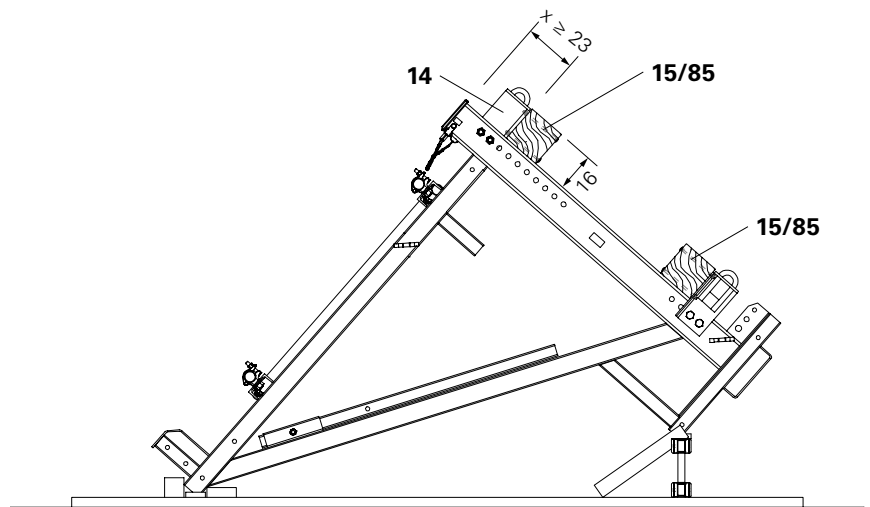

Fig. A1.13

Adjusting Unit CB 160

Assembly

When using TRIO, MAXIMO or VARIO GT 24, mount the Adjusting Unit CB 160 (16) with Bolts ISO 4014 M20 x 150-8.8 (17) and Nuts ISO 7042 M20-8 (18), SW 30.

The Adjusting Bolt (16.1) points to the guardrail side.
(Fig. A1.14)

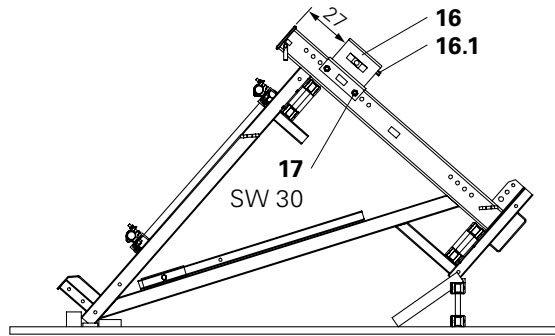

Fig. A1.14



Another position may be pre-defined in the plan!

Guardrail Post CB

Assembly

1. Release Bolts ISO 4014 M16 x 80-8.8 (6.2) and Nuts ISO 7042 M16-8 (6.3) (SW 24) and remove Guardrail Post CB 160 (6.1).
2. Insert Guardrail Post CB 160 (6.1) into the holder.
3. Secure with Bolt ISO 4014 M16 x 80-8.8 (6.2) and Nut ISO 7042 M16-8 (6.3).
4. Proceed in the same way with the second Guardrail Post CB 160.
(Fig. A1.15 or A1.16)

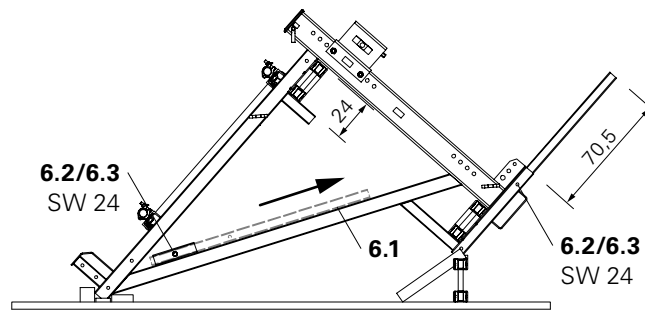

Fig. A1.15



Arrangement of the girder below: top hole in the guardrail post. (Fig. A1.15)

Arrangement of the girder above: bottom hole in the guardrail post. (Fig. A1.16)

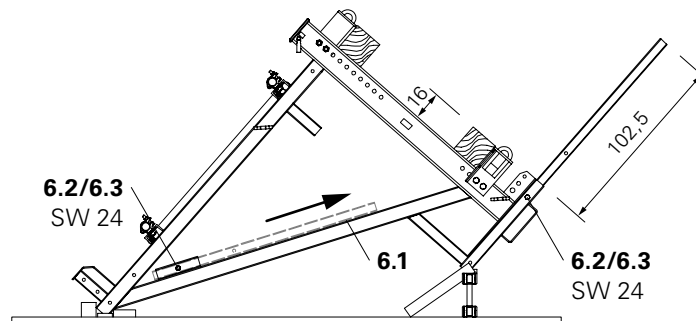

Fig. A1.16

Platform decking

Climbing platform, working platform

Assembly

1. Cut planking to size at right angles.
Length according to decking requirements. (Fig. A1.17 + A1.18)
2. Fix one planking each at the platform ends flush to girders (2 / 15). On the wall side, planking is flush with bracket front edge. Mounting:
TSS- Torx 6 x 80 2x per girder.
Alternatively: wire nails 38 x 100.
3. For accurate positioning, use plumb line.
4. Fix remaining planking.
5. Produce cut out for operating the securing bolt (6.4).
(Fig. A1.17a)



- If no platform decking has been included in the planning, it can be determined from C1 Platform decking.
- For girders positioned above, dimension x of the planking is to be used. The platform decking can be pre-assembled with girders placed in position and then fixed.
- For operating the securing bolts (6.4) from above, a spacing of $x \geq 23$ cm is required.
- Decking made of other materials must be sized to the same dimensions and then fixed.
- The installation of the hinged hatches is described in A2 Assembly of hinged hatch covers.
- Gaps in the decking ≤ 2 cm.

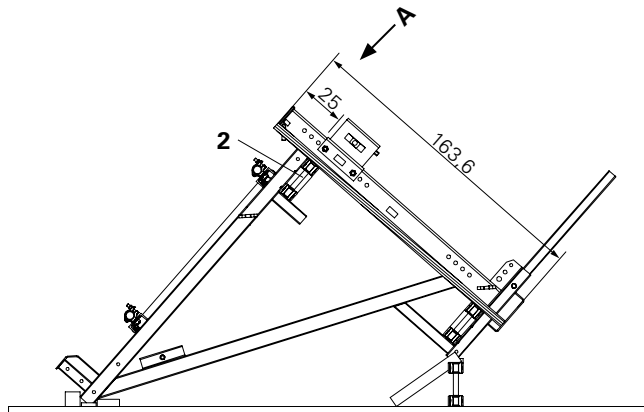

Fig. A1.17

View A

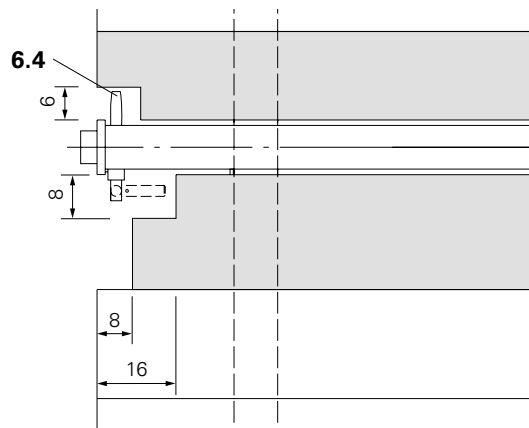

Fig. A1.17a

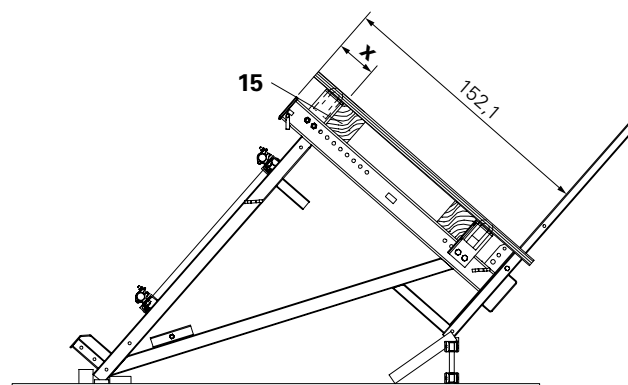

Fig. A1.18

Guardrails

Guardrail Post CB

1. Cut handrail boards (19) at right angles to match platform width.
2. Attach handrail boards (19) to Guardrail Post CB 160 (6.1) with screw clamps. Height: depends on decking configuration. (Fig. A1.19a + A1.19b)
3. Fix handrail boards (19) using 2x F. H. Bolt DIN 603 M8 x 100 (20). Pre-drill boards!
4. Depending on the decking configuration, fix Toe Board (21) to Guardrail Post CB 160 (Fig. A1.19b) using F. H. Bolt DIN 603 M8 x 100 MU (20) or mount on support bracket (6.5) using TSS-Torx 6 x 40 (22). (Fig. A1.19a)

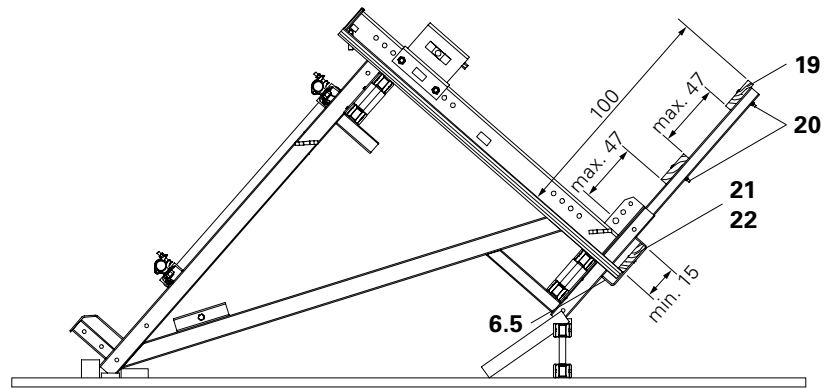

Fig. A1.19a



- If no guardrails have been included in the planning, they can be determined from C1 Handrails and guardrails.
- With larger cantilevers of the guardrail boards, the ends are to be connected with a vertically-positioned plank.



Handrail boards flush with the planking.

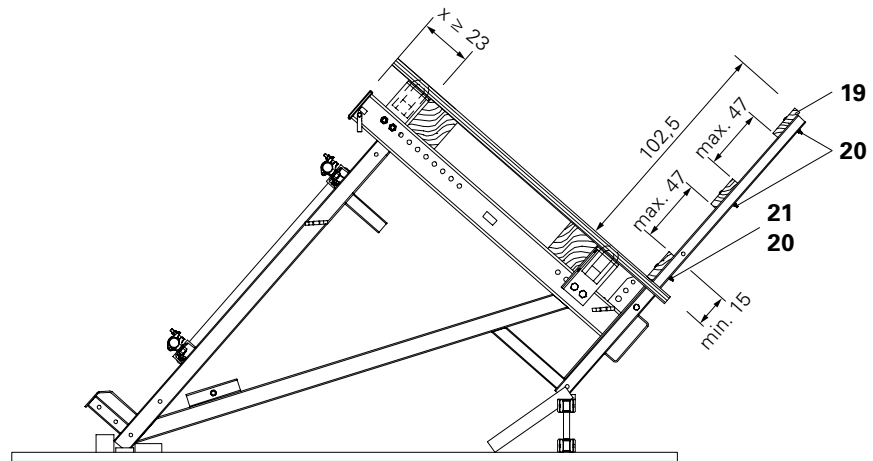

Fig. A1.19b

End Handrail Post CB

For longer cantilevers or larger bracket spacings, it is necessary to additionally support the handrail boards with the Intermediate Handrail Post CB.

1. Mark the outside edge of the End Handrail Post CB (23) on the handrail boards (19) and toe board (21).
2. Align Guardrail Post CB and fix to girder (2/15) with screw clamp.
3. Fix to girder using 6x Hex. Wood Screws DIN 571 6 x 80 (10).
4. Secure the pre-drilled handrail boards with packing using F. H. Bolts DIN 603 M8 x 125 MU (24).
(Fig. A1.20a + A1.20b)



If no span is specified in the planning, this can be determined from Section C1 Handrails and guardrails.

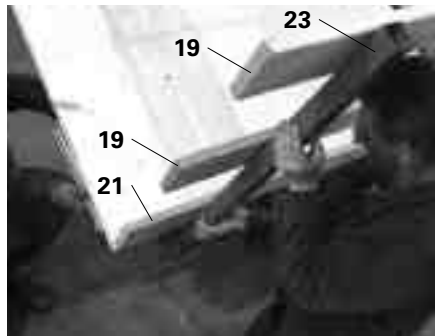

Fig. A1.20a

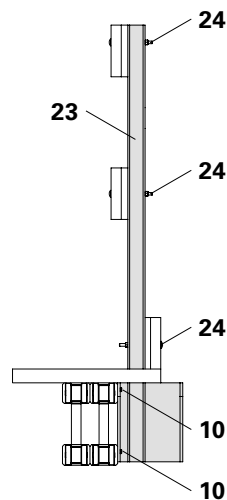

Fig. A1.20b

End Guardrail Post

Required materials:

- 2x Side Guardrail Post CB
- 2x handrail boards 4 x 12 cm
- 1x toe board 4 x 12 cm

Assembly

1. Fix Side Guardrail Posts CB (25) to the girders using 5x Hex. Wood Screws DIN 571 6 x 80 (10) each.
2. Fix handrail boards and toe board with F. H. Bolts DIN 603 M6 x 100 MU (12). (Fig. A2.01 + A2.01a)

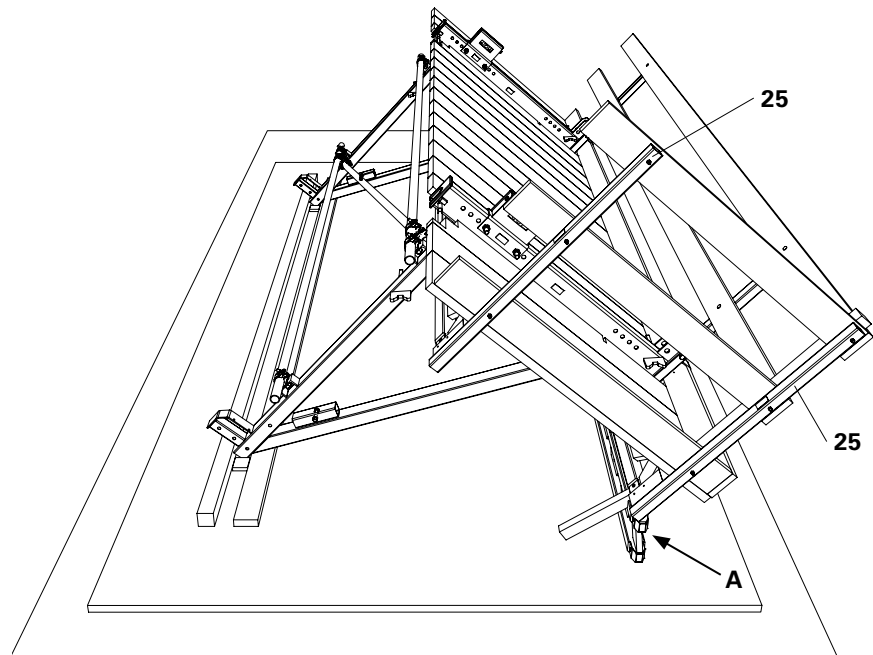

Fig. A2.01

View A

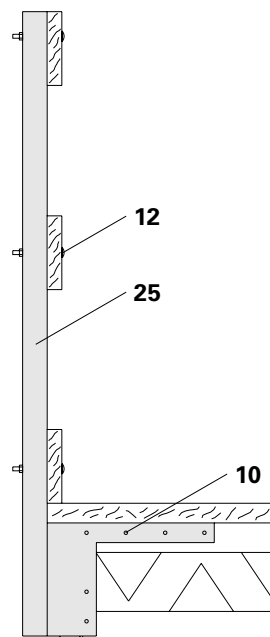

Fig. A2.01a

Hatch cover

Pre-assembly

- For installation, a 72 x 57 cm cut-out is made in the planking between the brackets.
- Remaining planking width ≥ 10 cm.
- The cut-out is arranged according to the configuration; formwork scaffolding: $a = 43.5$ cm, working scaffold: $a = 35$ cm.
- Support the cut planks with timbers (26), $L = 120$ cm, min. 120×40 mm, and secure with TSS-TORX 6 x 80 (29).
- Screw timbers (26) 2x each to the laterally-positioned end-to-end planking. F. H. Bolts DIN 603 M8 x 100 MU (20) with Washer ISO 7094 100 HV A8. (Fig. A2.02 + Fig. A2.03)



We recommend that the hatch, as featured, be installed close to the bracket in order that personnel can hold the spindle when climbing. (Fig. A2.04)

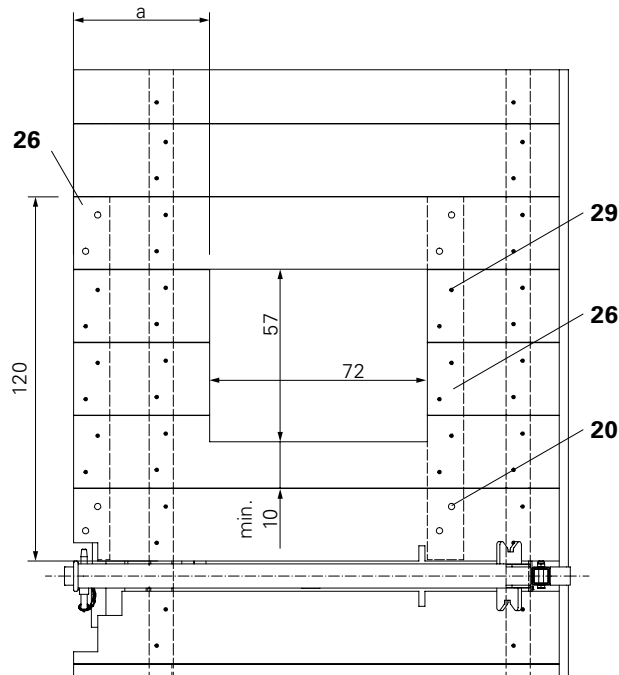

Fig. A2.02

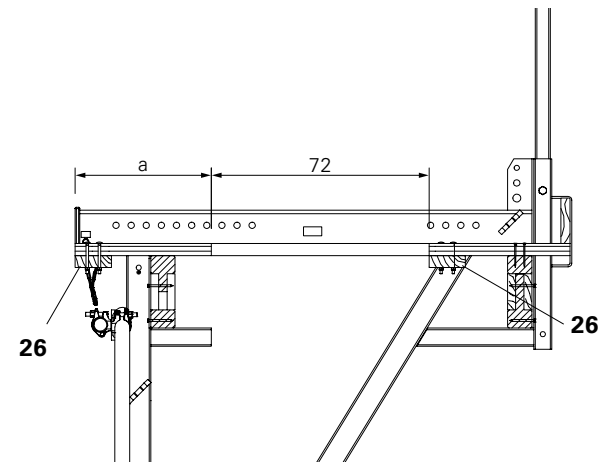

Fig. A2.03

Assembly

- Place foldable hatch 55 x 60 (27) in the cut-out. The cover (27.1) opens towards the wall side. (Fig. A2.04a)
- Attach hatch frame to the planking using approx. 20x TSS-TORX 6 x 40 (22). (Fig. A2.04)

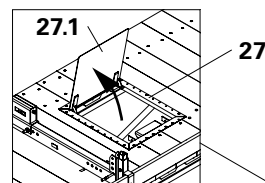

Fig. A2.04a

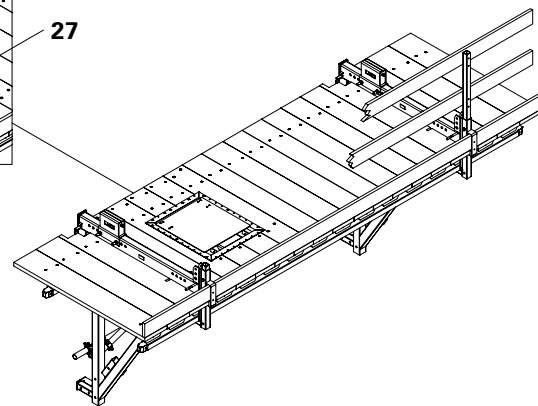

Fig. A2.04

Finishing platform

Platform Beam CB

1. Position Platform Beam CB (28) parallel in the bracket spacing on the assembly floor.
2. Place Lattice Girder GT 24 (2) and secure, see A1. (Fig. A2.05)



- If no girders have been included in the planning, they can be selected in Section C1 Platform decking.
- When using Lattice Girder GT 24, it is to be strengthened on both sides at the level of the platform beams with 2x wooden multi-layered boards; secure with F. H. Bolts DIN 603 according to A1.

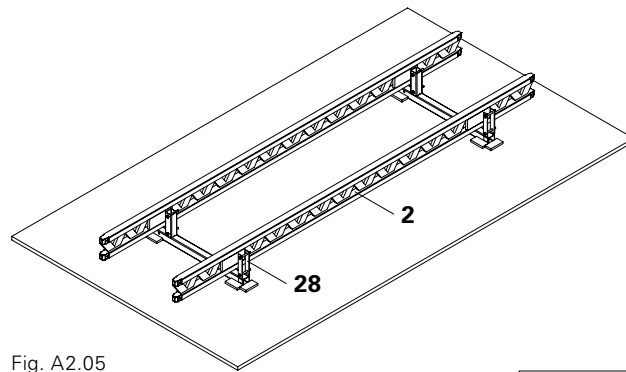

Fig. A2.05

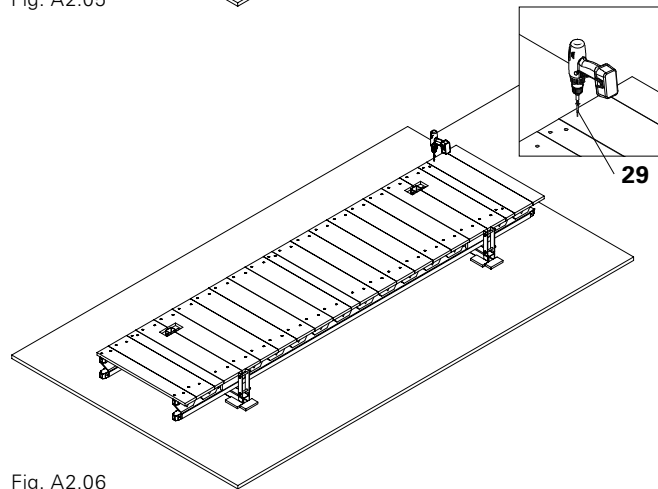

Fig. A2.06

Platform decking

1. Cut planking at right angles, $L = 1.170 \text{ m}$.
2. Fix one planking each at the platform ends flush to girders, see A1. Projecting length: 14 mm over girder on the wall side. (Fig. A2.06a) Mounting: TSS-Torx 6 x 80 (29), 2x per girder. Alternatively: wire nails 38 x 100.
3. For accurate positioning, use plumb line.
4. Fix remaining planking. (Fig. A2.06)



If no platform decking has been included in the planning, the planking can be selected in Section C1 Platform decking.

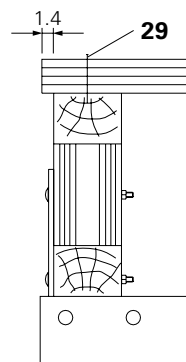

Fig. A2.06a

Assembly in the area of the Platform Beam CB

- The planking is divided along the middle of the Platform Beam CB (28).
- The planking (31) to the side of the Platform Post CB 225 (30) is complete!
- The planking is only tacked on. It must be removed again when the finishing platform is mounted.
- A cut-out is made in the area around the Platform Post CB 225. Provide for a circumferential 10 mm slit.
- The planking width in the compensation area is ≥ 100 mm. (Fig. A2.07)



Additional support (32) (planking) is screwed on under the planking.

Finishing tasks

- Mark the platform according to planning instructions e.g. with colour spray.



We recommend attaching a platform description, see C1 Drawings and plans.

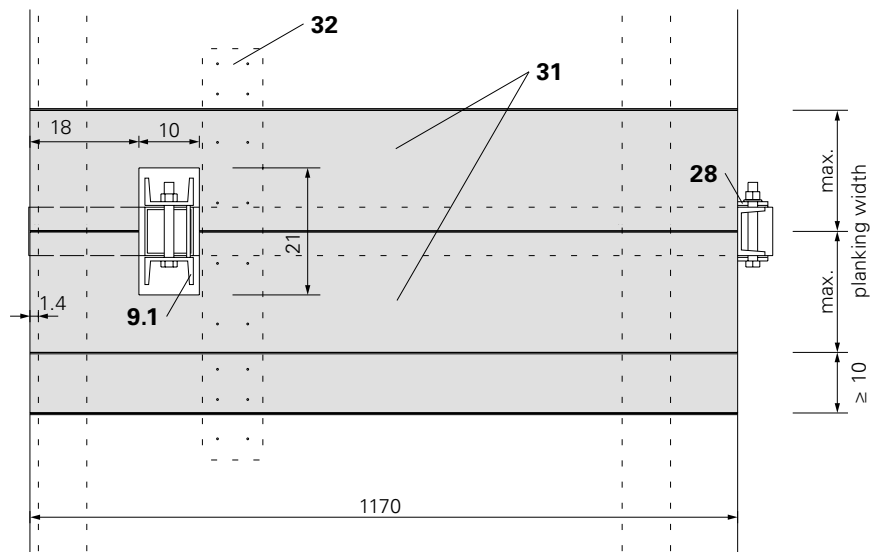

Fig. A2.07

Anchoring



- Each CB Bracket must be individually anchored, and the anchoring may only be loosened or dismantled on the side of the load transfer. The positioning of two cones against each other is not allowed. (Fig. B1.01)
- If $h_1 + h_2 < d$, the anchor positions must be horizontally or vertically offset. (Fig. B1.02 + B1.03)
- The correct installation of the climbing anchor is to be checked before concreting takes place. We recommend the compiling of an acceptance report.
- The climbing anchors must not be used until the load-bearing capacity of the anchorage is sufficient.
- The threaded areas on the Screw-On Cone-2 and Climbing Cone-2 as well as the Threaded Plates DW 15 and DW 20 must always be completely screwed in.
- The required anchoring depth h must not be achieved through a reduction of the screw-in depth.
- The tie rods must be chamfered at both ends.
- Damaged anchoring components must not be used.

Examples of damage:

- welding splashes on the tie rods
- bent tie rods
- rough-running threads
- deformed cone cups
- rough or scratched cone surfaces
- missing dowel pin in the climbing cone

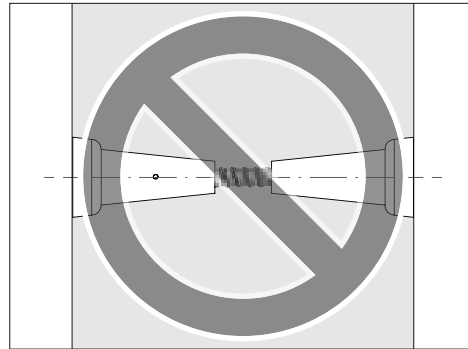

Fig. B1.01

Top view
horizontal offset

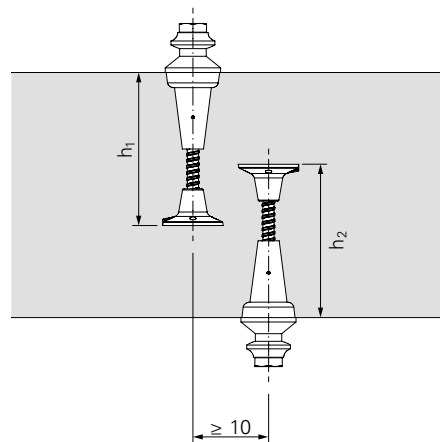

Fig. B1.02

Section
vertical offset

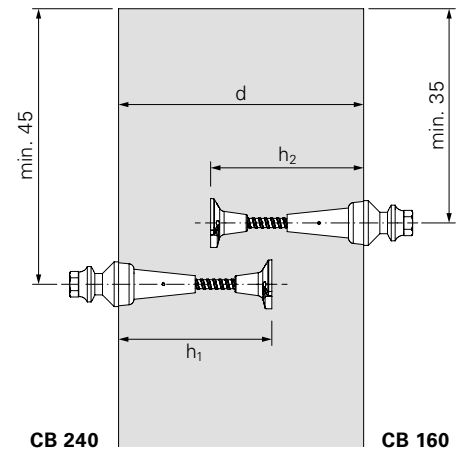

Fig. B1.03

Preparations for use



- With different concreting heights, anchor spacings with < 50 deviations can be compensated by means of the height adjusting unit. With larger deviations, more drilled holes are to be provided.
- During the first installation, compare the anchor spacing with the bracket spacing of the pre-assembled platform.
- Dimension and install the leading anchor according to planning requirements.
- Dimensions in mm.

Tie Rod DW 15

$$L_1 = h - 80$$

Spacer Tube DR 22

$$L_2 = h - 185$$

Variant 1

Climbing Cone-2 M24/DW 15

Anchoring depth h according to static requirements.

1. Check tie rod length.
2. Screw Tie Rod DW 15 (33) into the Climbing Cone-2 M24/DW 15 (34).
3. If necessary, pull Spacer Tube Rough DR 22 (35) over the Tie Rod DW 15 (33).
4. Completely screw in and tighten Threaded Anchor Plate DW 15 (36) on Tie Rod DW 15 (33). (Fig. B1.04a)

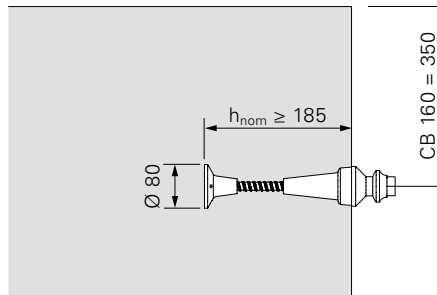

Fig. B1.04a

Variant 2

Screw-On Cone-2 M24/DW 20

Anchoring depth $h = 155$.

1. Fully insert Screw-On Cone-2 M24/DW 20 (37) into the Threaded Anchor Plate DW 20 (38). (Fig. B1.04b)

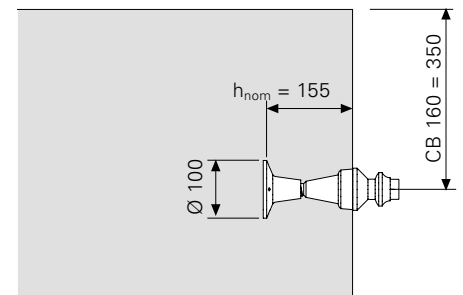
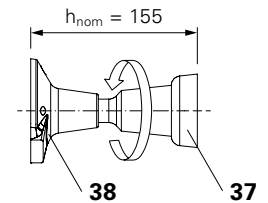
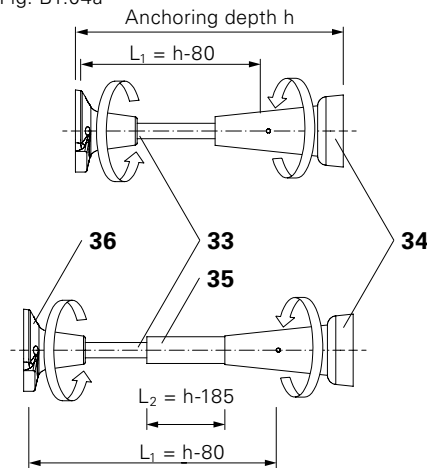

Fig. B1.04b



In order to facilitate the dismantling procedure, the climbing cones can be sealed with a silicone joint before installation at the screwing point of the tie rod. If sealing with silicone is not possible, the climbing cone can also be loosened by a quarter of a turn immediately after striking and then re-tightened. (Fig. B1.05)

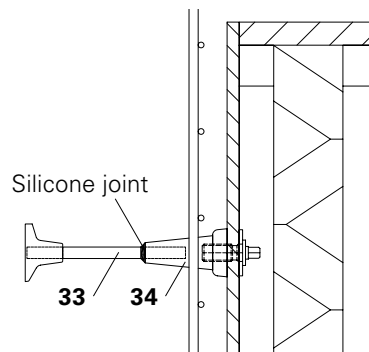

Fig. B1.05

Assembly of the leading anchor with Anchor Positioning Stud M24, e.g. for TRIO panel formwork.

Initial use and standard use

1. Fix Anchor Positioning Stud M24 (39) to the marked position using 4x wire nails 31 x 80 (40). (Fig. B1.06)
2. Tightly screw on and tighten pre-assembled leading anchor on Anchor Positioning Stud M24. (Fig. B1.07 + B1.08)



Fig. B1.06



- A more stable mounting is achieved through the installation of the Anchor Positioning Plate, see "Assembly of Advancing Bolt M24".
- In this case, the distances from the holes to be drilled to the steel struts of the formwork must be large enough.
- To secure in position, firmly connect the Threaded Anchor Plate (36/38) to the reinforcement.



Fig. B1.07



Check assembly

- height
 - anchor spacings
 - anchoring depth h
 - alignment according to specifications
- Leading anchor and reinforcement measures can be checked at the same time.

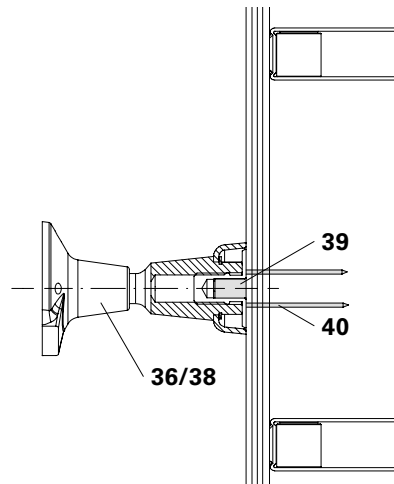

Fig. B1.08

Assembly of the leading anchor with Advancing Bolt M24, e.g. for VARIO GT 24 Girder Wall Formwork.

Initial use

1. Check the required space for the Anchor Positioning Plate M24 (41). A lateral clearance of 3 cm or 4 cm is required. (Fig. B1.10)
2. Determine the set position and drill \varnothing 25 mm hole from the front of the formwork. (Fig. B1.09)
3. Mount Anchor Positioning Plate M24 (41) on the rear of the formlining using 4x Wood Screws DIN 571 6 x 20, SW 10 (43). (Fig. B1.10)



Fig. B1.09

Standard use

1. Insert the Advancing Bolt M24 (42) from the rear side of the formlining through the drilled hole.
2. On the front side of the formlining, tightly screw on the leading anchor. (Fig. B1.11 + B1.12)



Fig. B1.10

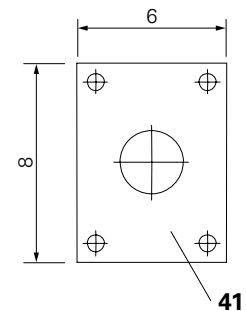

- If there is a formwork girder positioned at the rear of the anchoring, “Assembly with Anchor Positioning Stud M24” can be applied.
- Firmly connect the Threaded Anchor Plate (36/38) to the reinforcement to ensure a secure position.



Check assembly

- height
 - anchor spacings
 - anchoring depth h
 - alignment according to specifications
- Leading anchor and reinforcement measures can be checked at the same time.



Fig. B1.11

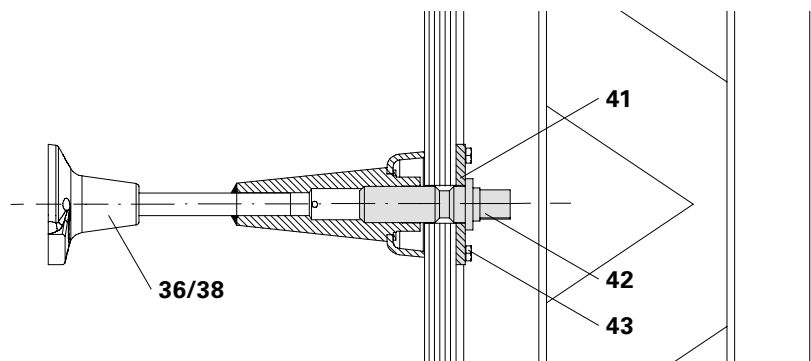

Fig. B1.12

When striking with the Anchor Positioning Stud M24 make sure to:

- Straighten out any bent wire nails.
- When retracting the formwork, the wire nails (40) must be pulled through the formlining. (Fig. B1.13)

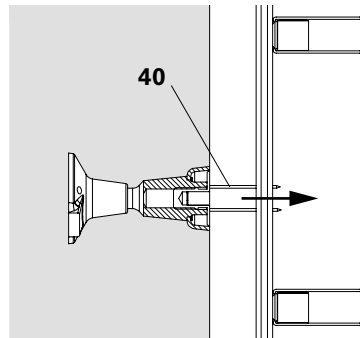

Fig. B1.13

When striking with the Advancing Screw M24 make sure to:

- Loosen and remove all Advancing Bolts M24 (42) from the rear side of the formlining. (Fig. B1.14)

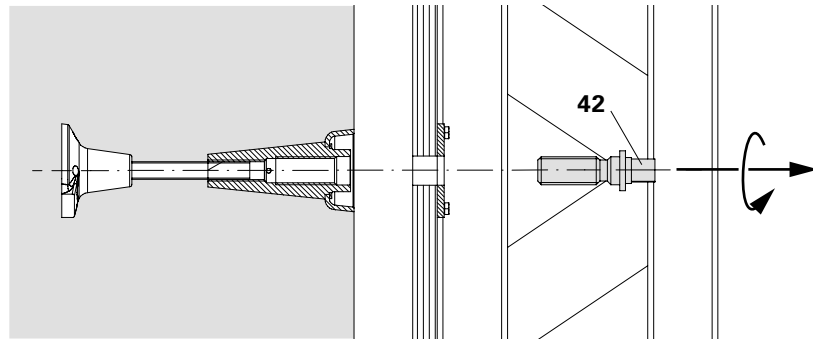

Fig. B1.14

Striking

1. Release connections to the adjoining elements (Coupling VKZ, Alignment Coupler BFD).
2. Loosen Adjusting Unit CB 160 (16).
3. Tilt formwork using Adjustable Brace CB 164-225 (44). (Fig. B1.15) In doing so, the nails from the Anchor Positioning Studs M24 (40) and box outs are pulled out of the formlining or at least loosened.

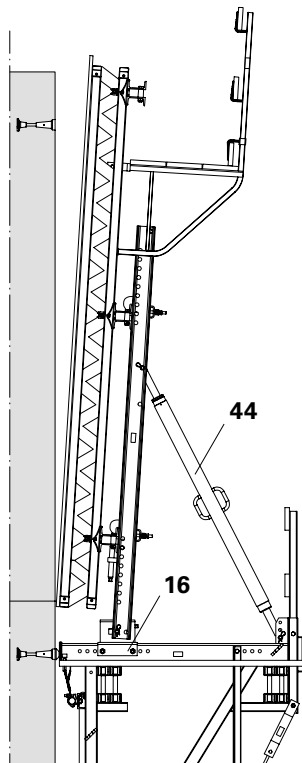

Fig. B1.15



Check if the climbing cones fit correctly and are clean.

Assembly of the Scaffold Mounting Ring M24

1. Remove the Anchor Positioning Stud M24 (39) from the cone by means of an Allen Key SW 14. (Fig. B1.16)
2. Place the Scaffold Mounting Ring M24 (45) on the cone cup of the Screw-On or Climbing Cone (34/37) and secure using Bolt ISO 4014 M24 x 120-10.9 (46). (Fig. B1.17)
3. Firmly tighten bolt by hand using Socket Wrench SW 36. (Fig. B1.18)

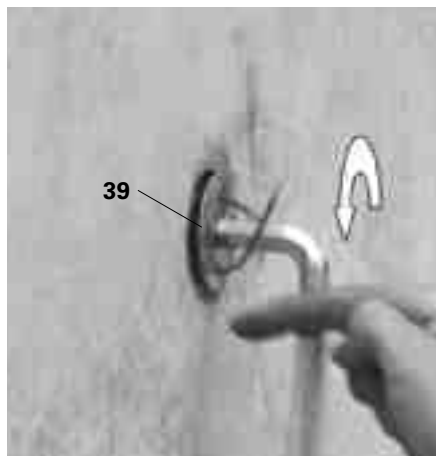

Fig. B1.16



Fig. B1.17



Fig. B1.18

Mounting the Working Platform CB 160 to the first wall section



- Follow Instructions for Use for the Platform Connection CB 160!
- Use 4-sling lifting gear with sufficiently long chains and securing devices!
- Crane sling angle max. 30°!
- Do not exceed the permissible load capacity!

Assembly

1. Secure two Platform Connections CB 160 (14) each to the Climbing Brackets CB 160.
2. Attach lifting gear hook to the bails of the Platform Connections CB 160 (47). (Fig. B1.19)
3. Remove securing bolts (6.4). (Fig. B1.20)

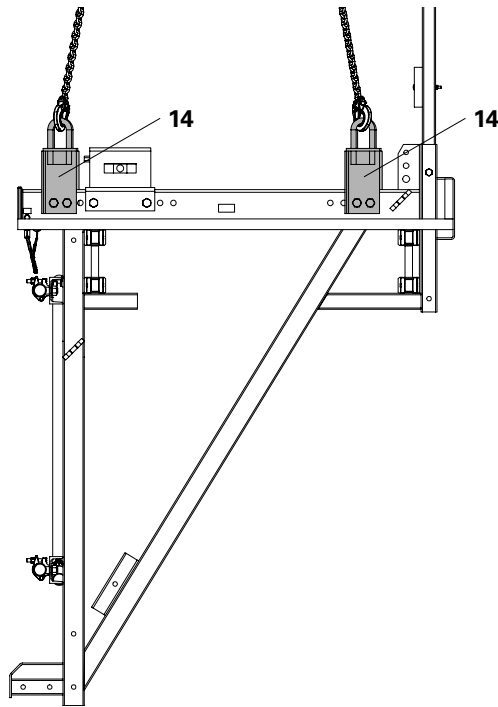

Fig. B1.19



Before moving

- Is the locking device on the lifting hook closed?
- Is the lifting angle correct?
- Have loose objects been removed?
- Have the securing bolts (6.4) been completely pulled out? (Fig. B1.21)

The platform is now ready to be moved.

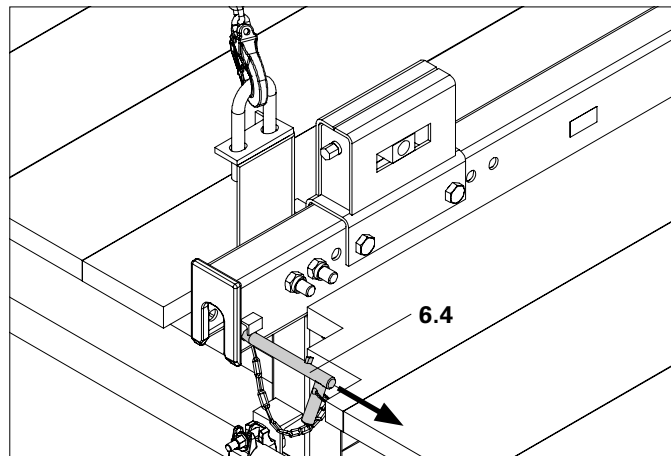

Fig. B1.20

Assembly

4. Raise platform and pivot over the Scaffold Mounting Rings. (Fig. B1.21)
5. Bring platform into position and simultaneously lower without tilting.

Troubleshooting

- If no connection is made with the Scaffold Mounting Rings (45) or if the Climbing Brackets CB 160 (6) jam, lift the platform and lower it again.
- If the bracket spacing does not match that of the Scaffold Mounting Rings, check the distance of the leading anchors on the formwork.
- If the mounting procedure is not possible, the bracket spacing must be corrected by re-assembling the platform.

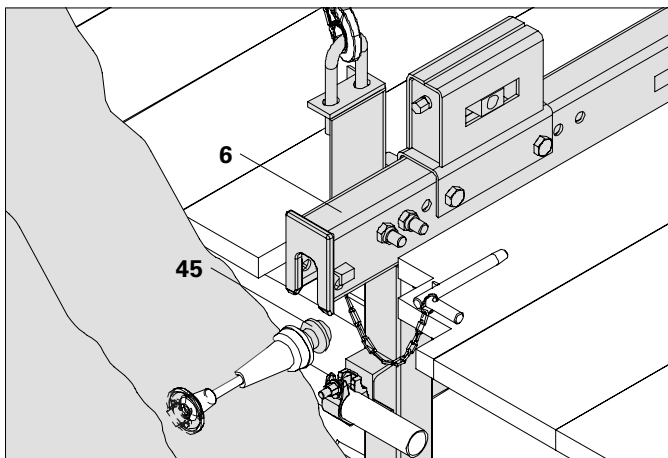

Fig. B1.21



Are the Climbing Brackets CB 160 (6) attached to both Scaffold Mounting Rings M24 (45)?

Securing the platform



If the securing bolts cannot be inserted, repeat the procedure!

Assembly

1. Access the platform.
2. Insert securing bolts (6.4) into the opening under the Scaffold Mounting Ring (45) and secure by turning to a vertical position. (Fig. B1.22)
3. Remove crane hook. Mounting of the formwork, see B2 / B3.

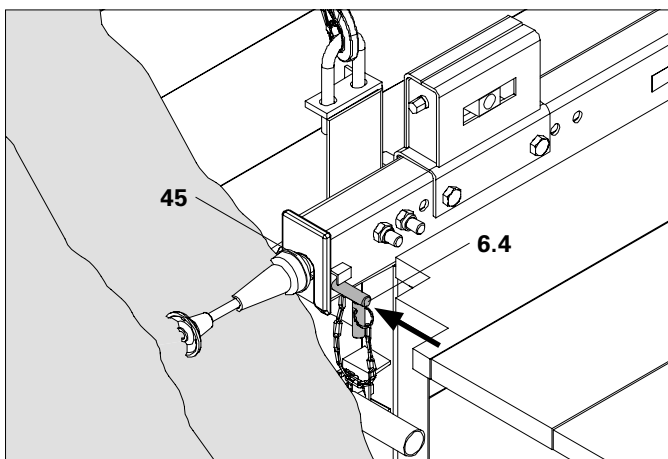

Fig. B1.22

Mounting the Finishing Platform CB 160

Preparation

1. Remove tacked on planking parts from both sides of the platform beam.
2. Attach 4-sling lifting gear to the four Bolts ISO 4014 M16 x 130-8.8 (48) and move finishing platform to the assembly area. (Fig. B1.23)

Connecting to the brackets

Connections are carried out using Bolts ISO 4014 M16 x 130-8.8 (48) and Nuts ISO 7042 M16-8 (49) (supplied with components). Initially, only loosely tighten bolts for the articulated connections.

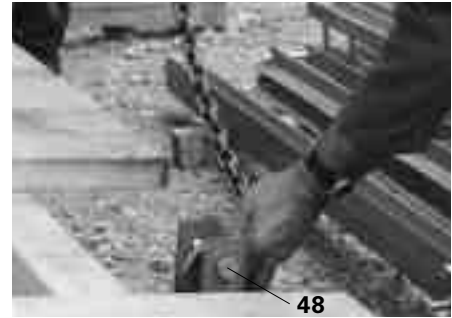

Fig. B1.23

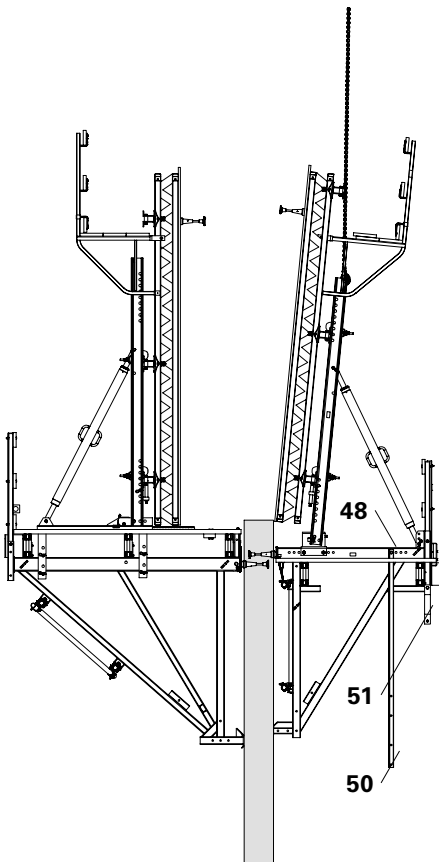

Fig. B1.24

1. Connect Guardrail Post CB 200 (50) to the Climbing Bracket CB 160 (6) and tighten Bolts ISO 4014 M16 x 130-8.8 (48). Bolt on Belt Connector CB (51), see B1 Wind bracing.
2. Attach platform unit to strongback and lift out of the anchoring. Do not exceed the crane capacity, see B4. (Fig. B1.24)
3. Pivot platform unit over the finishing platform.

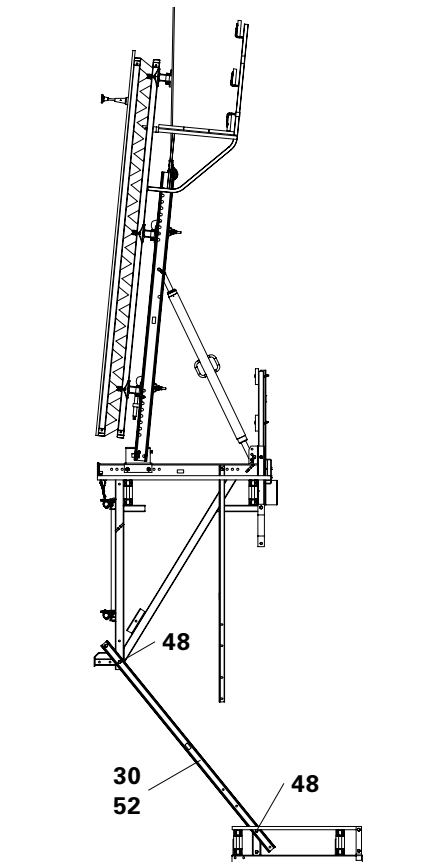

Fig. B1.25

4. If necessary, firmly bolt the Platform Post CB 225 (30) to the Post Extension CB 180 (52), and attach to the bracket and finishing platform forming an articulated connection using Bolts ISO 4014 M16 x 130-8.8 (48). (Fig. B1.25) Depending on the concreting height, use top or bottom hole. (Fig. B1.26)

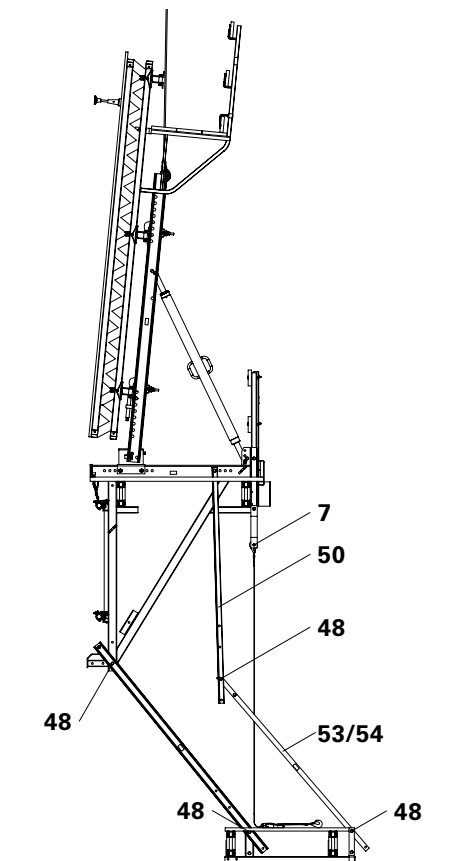

Fig. B1.26

5. Fix the Guardrail Post CB 190 (53) or Guardrail Post 370 (54) to Guardrail Post CB 200 (50) forming an articulated connection using Bolts ISO 4014 M16 x 130-8.8 (48). Depending on the concreting height, use top or bottom hole. (Fig. B1.26a - d) Attach Tension Belt L = 5.70 m, 2.5 t (55). (See Section B1)
6. Fix the toe board at the lower end. (Fig. B1.26)

Fixing points for the Platform Posts CB 225 and Guardrail Posts CB 190 and CB 370.

Initially, only loosely tighten Bolts ISO 4014 M16 x 130-8.8 (48) for an articulated connection.

Concreting height 1.50 – 3.10 m

Distance of the working platform to the finishing platform 3.65 m.

Required free space: ≥ 0.42 m.

Mark out Platform Post CB 225 (30) and Guardrail Post CB 190 (53) at the top.

(Fig. B1.26a)

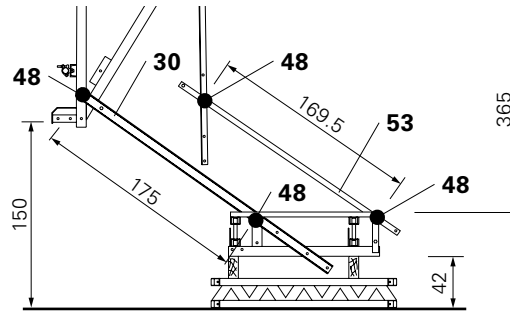

Fig. B1.26a

Concreting height 2.00 – 3.60 m

Distance of working platform to the finishing platform 4.15 m.

Mark out Platform Post CB 225 (30) and Guardrail Post CB 190 (53) at the bottom.

(Fig. B1.26b)

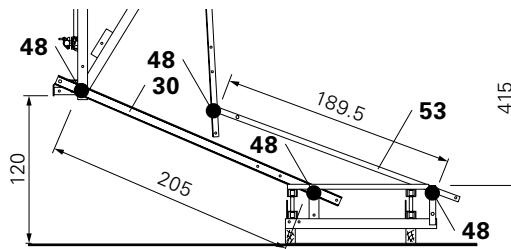

Fig. B1.26b

Concreting height 3.30 – 4.90 m

Distance of the working platform to the finishing platform 5.45 m.

Firmly bolt the Platform Post CB 225 (30) to the Post Extension CB 180 (52) using Bolts ISO 4014 M16 x 130-8.8 (48). Mark out Guardrail Post CB 370 (54) at the top.

(Fig. B1.26c)

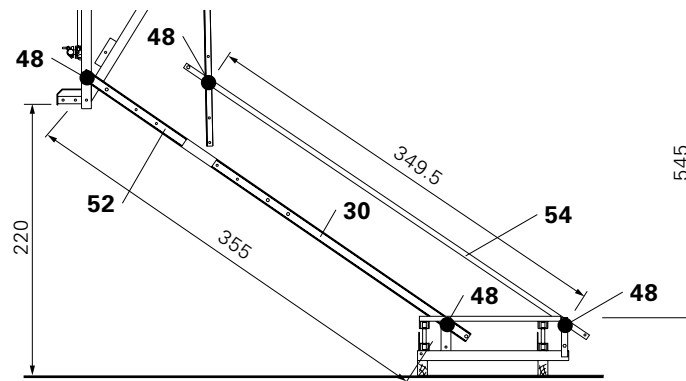

Fig. B1.26c

Concreting height 3.80 – 5.40 m

Distance of the working platform to the finishing platform 5.95 m.

Firmly bolt the Platform Post CB 225 (30) to the Post Extension CB 180 (52) using Bolts ISO 4014 M16 x 130-8.8 (48). Mark out Guardrail Post CB 370 (54) at the bottom.

(Fig. B1.26d)

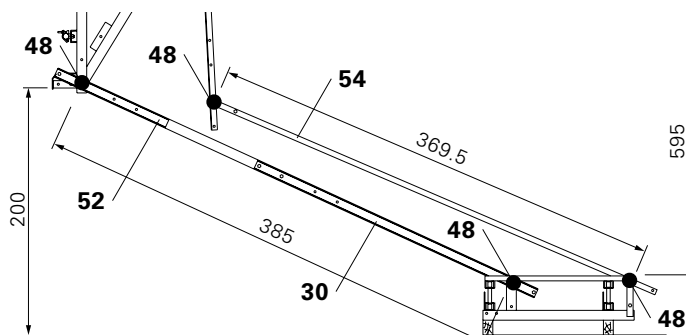

Fig. B1.26d

CB 160 Climbing Formwork

Instructions for Assembly and Use – Standard Configuration

Finishing tasks

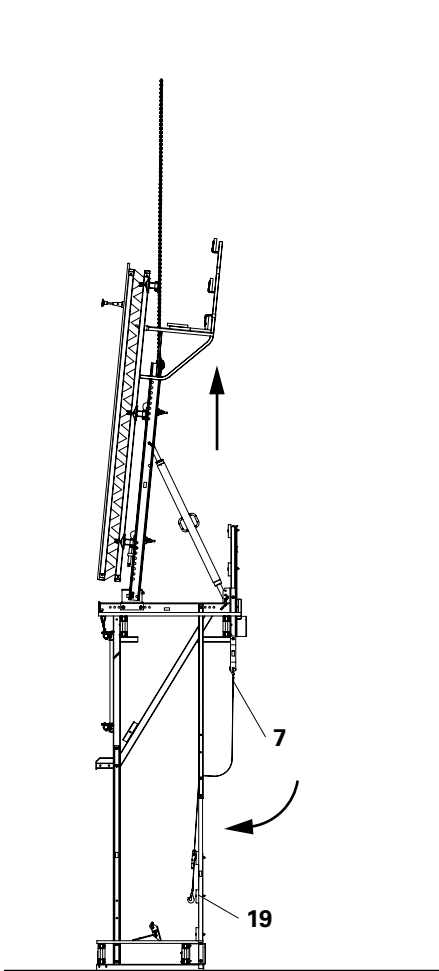

Fig. B1.27

7. Slowly lift the platform unit. The finishing platform pivots under the working platform.
8. Guardrails: for the edge platforms, mount handrail boards (19) using F. H. Bolts DIN 603 M8 x 70 MU, see C1 Guardrails. (Fig. B1.27)
Alternatively: safety rails can also be mounted after installing the platform unit if suitable safety measures are in place.

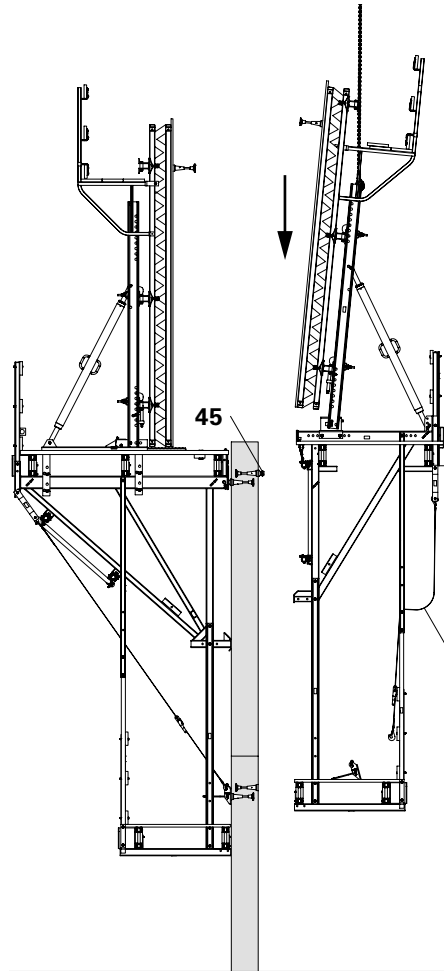

Fig. B1.28

9. Lower the platform unit from the structure and attach it to the Scaffolding Mounting Ring (45) for the next climbing cycle. (See Section B4)
10. Close the planking on the finishing platform. (Fig. B1.28)
11. Mount missing Bolts ISO 4014 M16 x 130-8.8 (48) and Nuts ISO 7042 M16-8 (49). Tighten bolts.

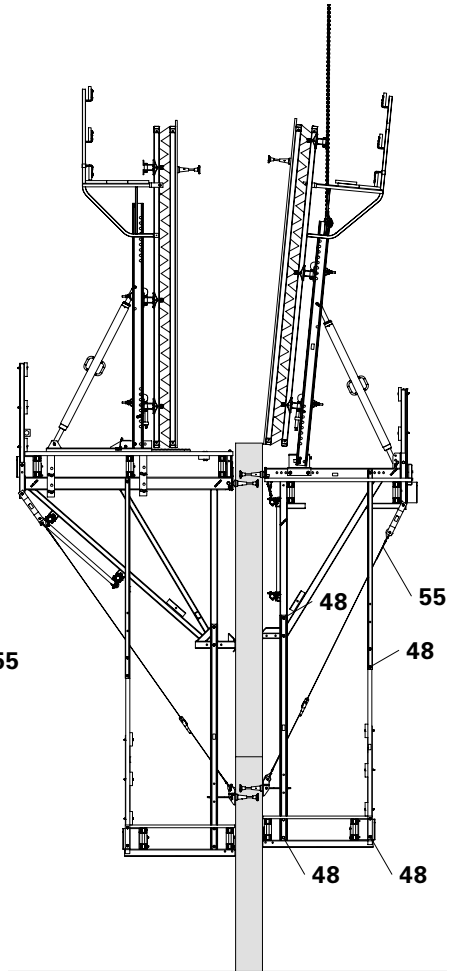

Fig. B1.29

12. Mount Tension Belt L = 5.70 m, 2.5 t (55), see B1 Wind bracing. (Fig. B1.29)



For a controlled moving procedure of the units, always use a guide rope.

Assembly of wind bracing

With Tension Belt 25 kN

Permissible tension anchor force $Z_z = 25 \text{ kN}$.

1. Attach Tension Belt Connector CB (51) using Bolt M16 x 100, SW 24 to the vertical tube of the Climbing Bracket CB 160 (6.6).
2. Mount Tension Belt L = 5.70 m, 2.5 t (55) to the bolts using the end of the belt without a turnbuckle. (Fig. B1.30)
3. Loosen Scaffold Mounting Ring and Bolt M24 x 120 (45) on the previous concreting segment using socket wrench SW 36, and remove. (Fig. B1.31)
4. Fix Bracing Shoe Wall CB M24 (56) to the cone using Bolt ISO 4014 M24 x 70-10.9 (58) SW 36 after the bolts have been removed from the tension plate (56.1). Re-insert tension plate through the platform post and re-bolt in the Bracing Shoe Wall CB M24 (56). (Fig. B1.32)
5. Unroll Tension Belt L = 5.70 m, 2.5 t (55) from the ratchet.
6. Attach Tension Belt L = 5.70 m, 2.5 t (55) below in the Bracing Shoe Wall CB M24 (56), and tighten. (Fig. B1.33)

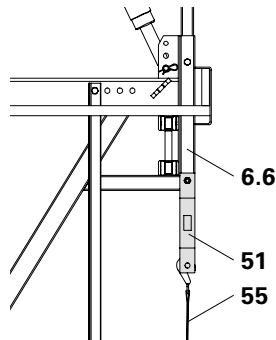

Fig. B1.30

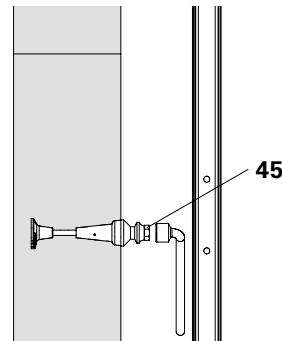

Fig. B1.31

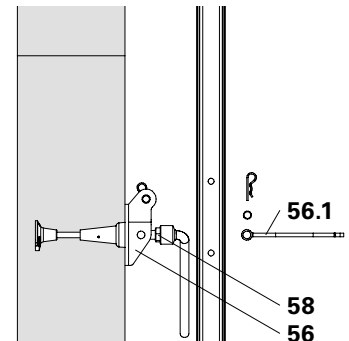

Fig. B1.32



- If lateral stabilisation of the finishing platform is not required, then the Belt Connector Wall M24 (57) can also be used instead of the Bracing Shoe. (Fig. B1.33a)
- For the use and care of the Tension Belts, see EN 12195-2, Appendix B.

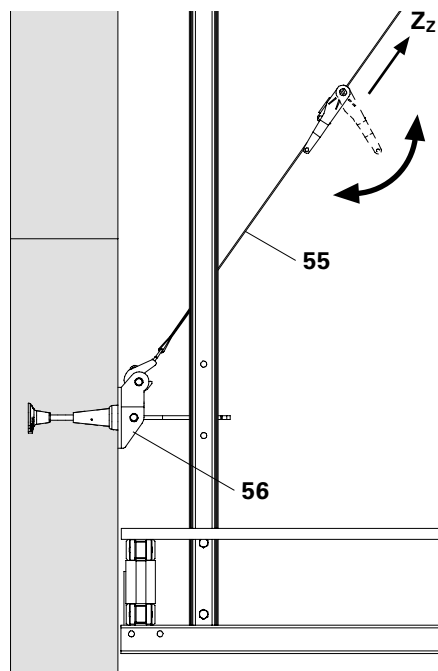

Fig. B1.33

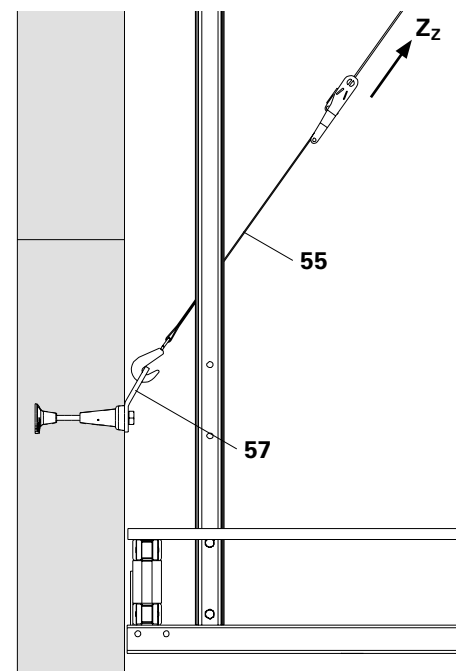

Fig. B1.33a

With Tie Rod DW 15

Permissible tension anchor force
 $Z_z = 41 \text{ kN}$.

1. Attach Tension Anchor Connector CB (59) using Bolt M16 x 100, SW 24 to the vertical tube of the Climbing Bracket CB 160 (6.6). (Fig. B1.34a)
2. Screw Tie Rod DW 15 (33) into the nut of the Tension Anchor Connector CB (59). (Fig. B1.34b)
3. Loosen Scaffold Mounting Ring and Bolt M24 x 120 (45) on the previous concreting segment using socket wrench SW 36, and remove. (Fig. B1.31)
4. Fix Bracing Shoe Wall CB M24 (56) to the cone using Bolt ISO 4014 M24 x 70-10.9 (58) SW 36 after the bolts have been removed from the tension lug (56.1) of the Bracing Shoe. Re-insert tension lug through the platform post and re-bolt in the Bracing Shoe Wall CB M24 (56). (Fig. B1.32)
5. Screw Turnbuckle CB M20/DW 15 (60) onto the Tie Rod DW 15 (33). (Fig. B1.34c) Roughly adjust length by turning the tie rod. Fine adjustment by turning the turnbuckle.
6. Insert Eyelet Bolt $\varnothing 25$ (60.1) into the Bracing Shoe Wall CB M24 (56) and secure with designated bolt and cotter pin. (Fig. B1.34d)
7. Turn turnbuckle, e.g. with shortened tie rod, thus tensioning the wind bracing. (Fig. B1.34f)

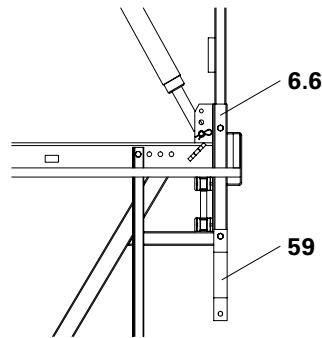

Fig. B1.34a

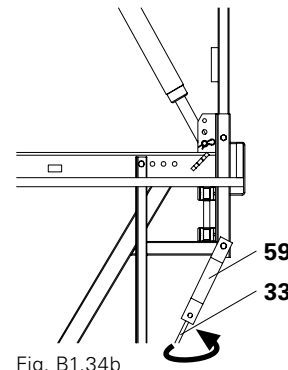

Fig. B1.34b

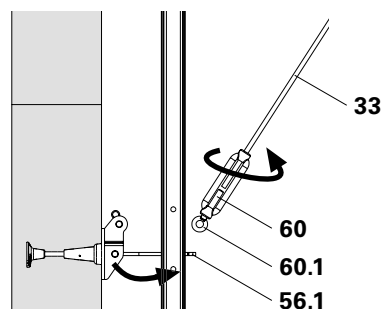

Fig. B1.34c

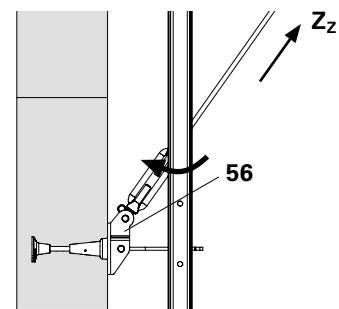

Fig. B1.34d

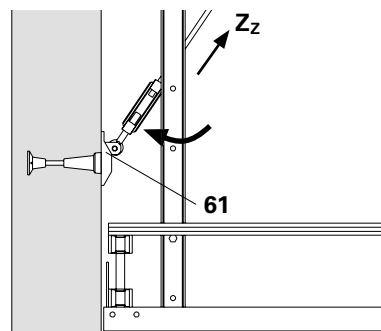

Fig. B1.34e



Fig. B1.34f



If lateral stabilisation of the finishing platform is not required, then the Wall Tension Anchor (61) can also be used. Loosen turnbuckle, turn on tie rod and insert into the Tension Anchor Connector. (Fig. B1.34e)

Formula for calculating the length of Tie Rod DW 15.

With Bracing Shoe Wall CB M24

$$L = \sqrt{(H - 22,5)^2 + 232,6^2} - 51$$

H = concreting height in cm = vertical spacing of the climbing anchors
 L = tie rod length in cm

With Wall Tension Anchor

$$L = \sqrt{(H - 16,4)^2 + 233,6^2} - 51$$

Removal of the climbing cones

Assembly

1. Remove Scaffold Mounting Ring M24 or wind bracing.
2. Release cone with socket wrench SW 36. (Fig. B1.35a)
3. Unscrew cone by hand. (Fig. B1.35b)



For architectural concrete or required gas/water impermeability of the wall, the cone hole can be closed with PERI Sealing Cones KK.

See Instructions for Use for Concrete Cones or contact your PERI sales engineer.

(Fig. B1.35c)



Fig. B1.35a



Fig. B1.35b



Fig. B1.35c



Dismantling

Dismantling

1. Dismantle formwork.
2. Attach 4-sling lifting gear to Platform Mountings CB (14).
3. Remove securing bolts (6.4).
4. Lift working platform out of the anchoring and disassemble finishing platform. (Fig. B1.36)
5. Set down working platform on the assembly area and dismantle.
6. Remove anchors from building ensuring that personnel are always in a safe working position.

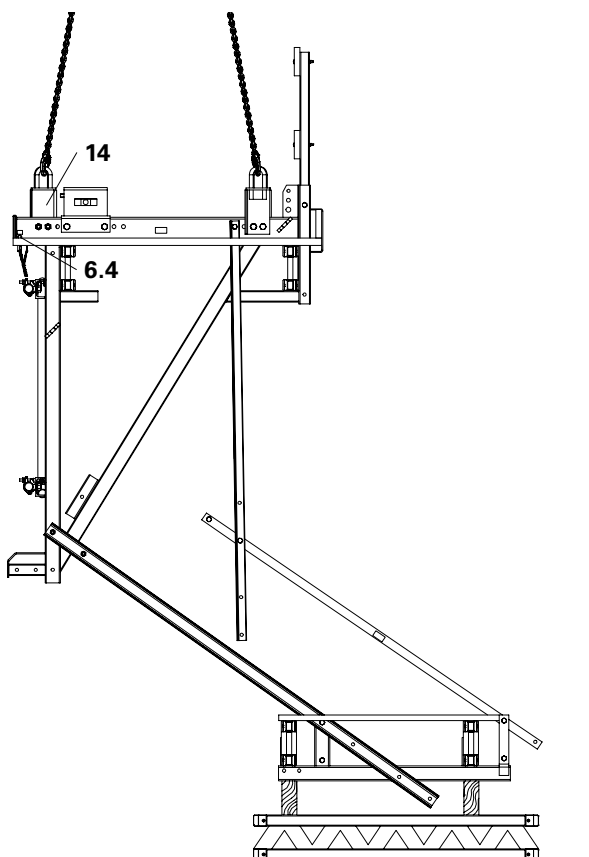

Fig. B1.36

Ladder assembly

Overview

Mounting of ladder is dependent on the position of the finishing platform. There are four concreting heights. (Fig. B1.37a – B1.37d)
For assembly of (hinged) hatch cover see A2.



If the safety cage is not used on the ladder, then the guardrails on the finishing platform are to be mounted up to the top or a safety net is to be installed!

Concreting height 1.50 – 3.10 m

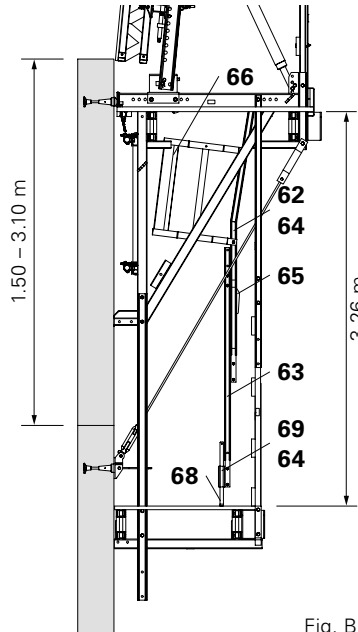

Fig. B1.37a

Concreting height 2.00 – 3.60 m

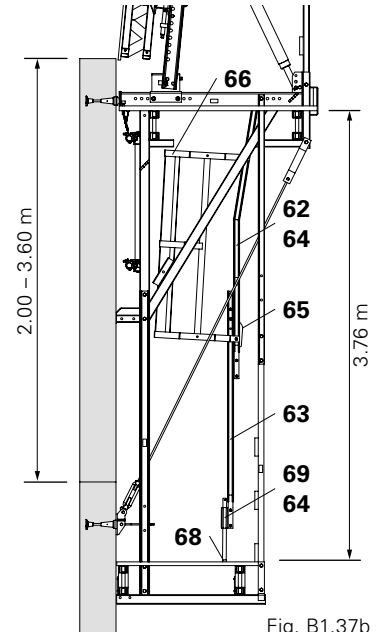

Fig. B1.37b

Concreting height 3.30 – 4.90 m

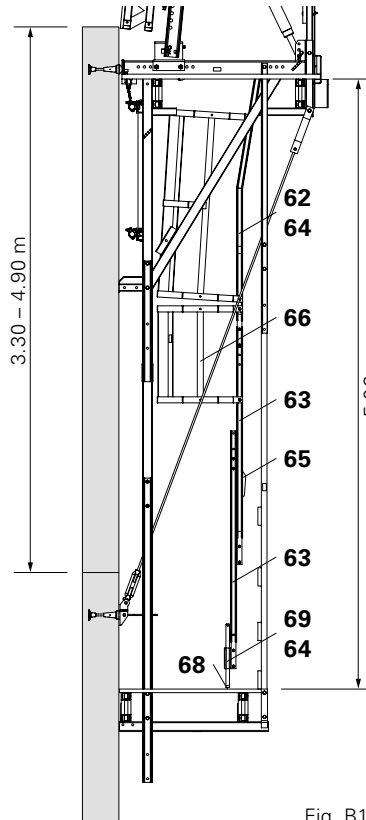

Fig. B1.37c

Concreting height 3.80 – 5.40 m

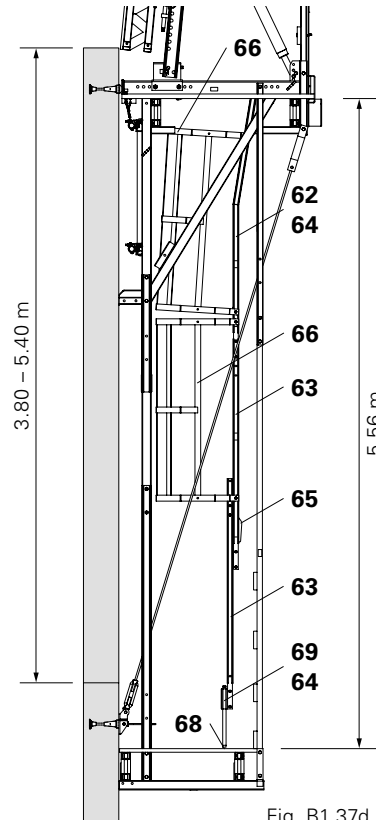

Fig. B1.37d

Pre-assembly of ladder

1. Ladder use: Ladder 220/6 (62) at the top, Ladder 180/6 (63) at the bottom.
2. Connect ladders using Bolts ISO 4017 M12 x 40-8.8 (64), SW 19. (Fig. B1.50)
3. Secure Ladder Base (30) (69) using Bolts ISO 4017 M12 x 40-8.8 (64), SW 19. (Fig. B1.38)

If the bottom ladder is of a hook-on type, fix Ladder Hook (65) using Bolts ISO 4017 M12 x 25-8.8 (67), SW 19. (Fig. B1.39)



When mounting the bottom ladder, the rungs must be at the same level. (Fig. B1.40)

Attaching the ladder to the hatch

1. Lift ladder using the crane. Lower ladder through hatch opening.
2. Fix ladder to the hatch from the top using 2x Bolts ISO 4017 M12 x 40-8.8 (64), SW 19. (Fig. B1.41)

Mounting the ladder base

1. For horizontal mounting of the ladder, tightly screw the drawn-out bracket of the Ladder Base 30 to the planking using 3 TSS-Torx 6 x 40 (68).

Mounting the ladder safety cage

1. Bring and hold Ladder Safety Cage (66) in position using a rope.
2. Slightly loosen Bolts ISO 4017 M12 x 25-8.8 (67), SW 19 (4x) on the clamping plate (66.1), position clamping plate on the ladder longitudinal members, turn and tighten bolts. (Fig. B1.42)

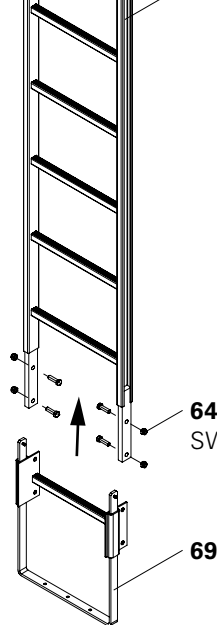
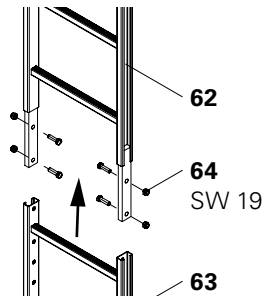

Fig. B1.38

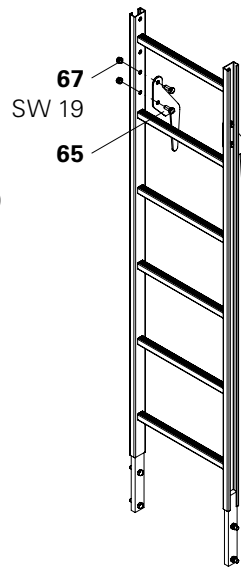

Fig. B1.39

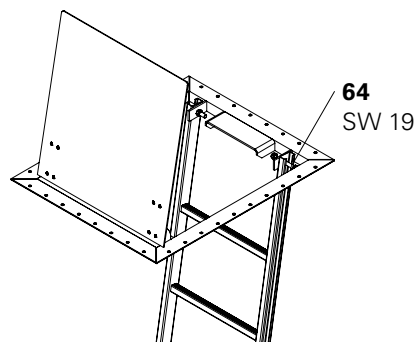

Fig. B1.41

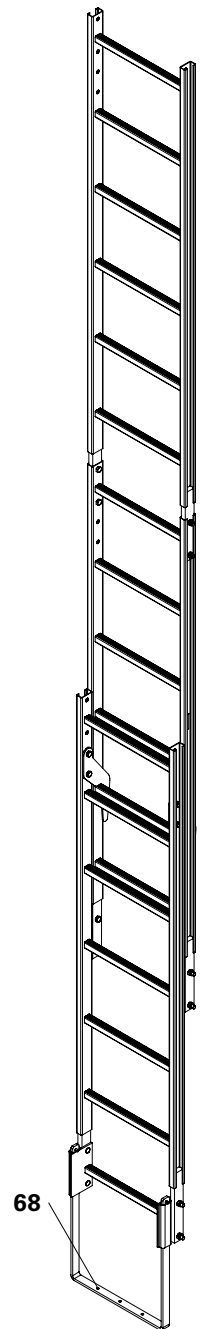

Fig. B1.40

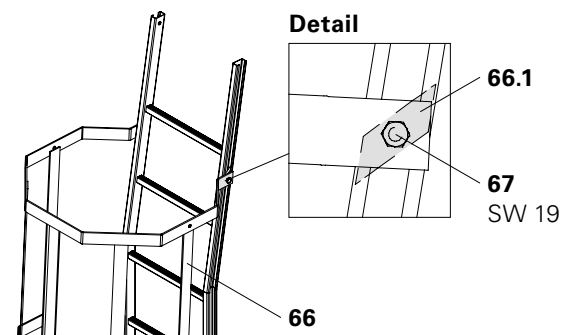

Fig. B1.42

VARIO GT 24 Panel

Assembly of Strongback CB on the VARIO GT 24 Panel

1. Lay Strongback CB 270 or CB 380 (70) on the steel waler of the VARIO GT 24 Panel according to the bracket spacing. Bottom projecting length: see plans or C1. (Fig. B2.01)
2. Mount Waler Fixation U100 – U120 (71) and secure in position by tightening the Quick Jack Nut. (Fig. B2.02)
3. Fix Height Adjusting Unit CB, SCS (72) with Bolts $\text{\O} 25 \times 180$ (73) and Cotter Pin 4/1 to the Strongback CB (70). (Fig. B2.03)
4. Turn Spindle (72.1) of the Height Adjusting Unit against the formwork waler.



Fig. B2.01

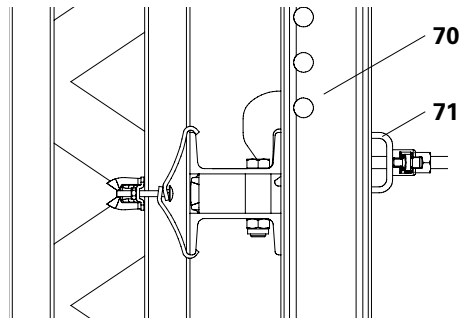

Fig. B2.02



The Waler Fixation U100 – U120 can be attached to the SRZ Steel Waler U100 and U120.

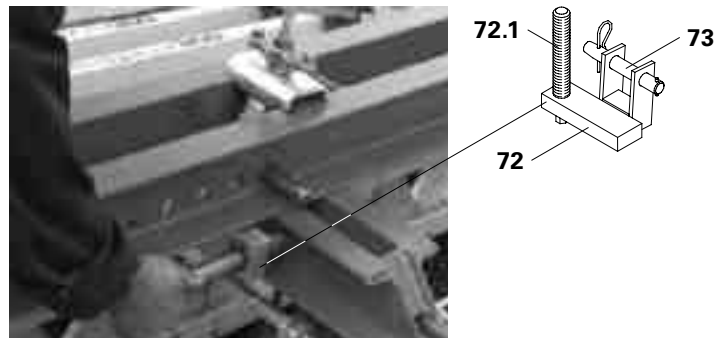

Fig. B2.03



In order to prevent the Strongbacks from being pulled out of position at any time, a piece of timber (4.10) is clamped between the top ends of the Strongbacks, see C1 Moving.

(Fig. B2.04)



Alternatively, use Lifting Beam RCS 10 t (Item no. 112986) for moving.

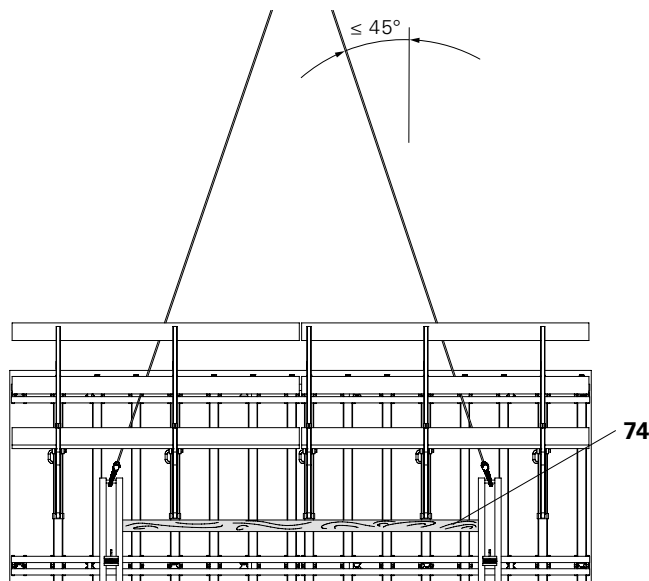

Fig. B2.04

Assembly of VARIO GT 24 Formwork Panel on the Bracket CB 160

1. Completely move back the sliding block (16.2) of the Adjusting Unit CB 160 (16), SW 19, see B3. (Fig. B2.05a)
2. Open or cut out decking of the concreting platform (31) in the area of the strongback. Secure loose decking components.
3. Attach formwork (78) together with concreting platform to the Strongback CB 160 (70), and position on the platform. (Fig. B2.05b)
4. Fix Strongback to the Adjusting Unit CB 160 (16) by means of Bolts $\varnothing 25 \times 180$ (73) and Cotter Pins 4/1. Standard case: use those holes in the Strongback facing the wall. (Fig. B2.05c)
5. Fix Adjustable Brace CB 164-224 (44) to the bracket using Bolts $\varnothing 25 \times 180$ (73) and Cotter Pins 4/1. Spindle out to approximate length and attach to Strongback. (Fig. B2.05c)
6. Detach lifting gear. Close decking on concreting platform.
7. Turn sliding block (16.2) of the Adjusting Unit with formwork to the wall, SW 19. (Fig. B2.05d)
8. Align formwork, see B3.



For a controlled moving procedure of the units, always use a guide rope.

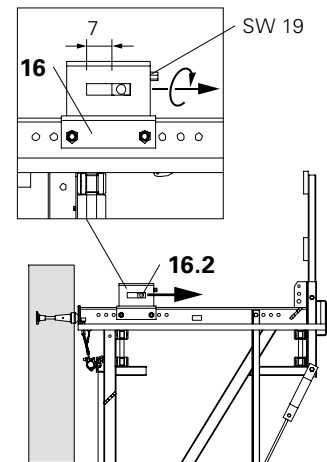

Fig. B2.05a

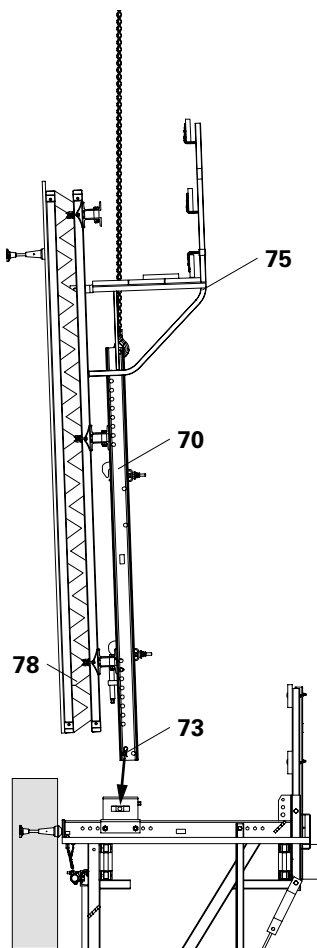

Fig. B2.05b

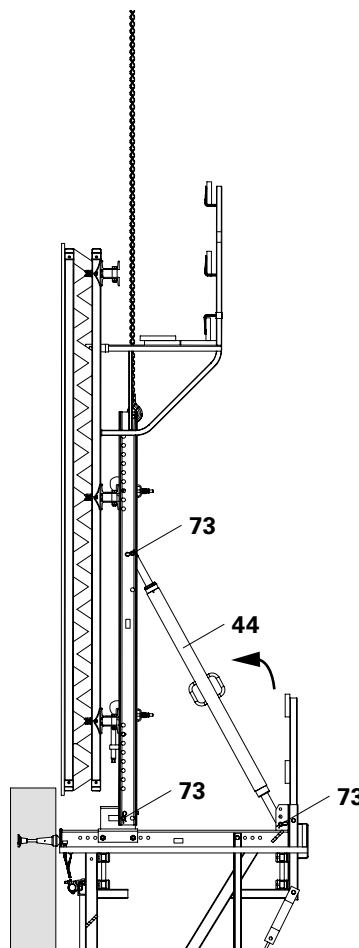

Fig. B2.05c

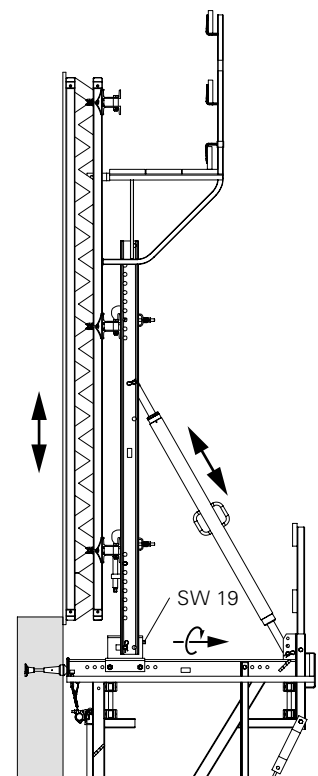

Fig. B2.05d

Moving of VARIO GT 24 Panels



Follow the Instructions of Use for the Crane Splice 24!

Dismantling

1. Move back the sliding block (16.2) in the Adjusting Unit, SW 19, and laterally brace the Strongbacks.
2. Attach formwork (78) to the Crane Splice 24 (76) and tension lifting gear.
3. Remove all Water Fixations U100 – U120 (71).
4. Raise formwork and remove (e.g. storage area). (Fig. B2.06)



When laying the formwork down, the handrail boards (19) of the Scaffold Bracket GB 80 (77) must be removed (by the contractor) in order to avoid any damage caused by the lifting gear.

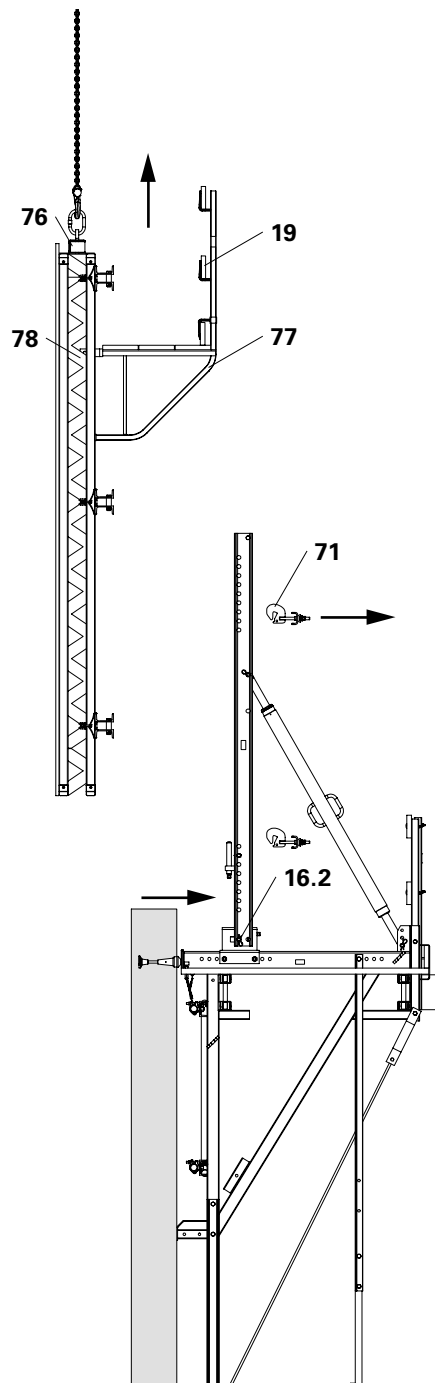
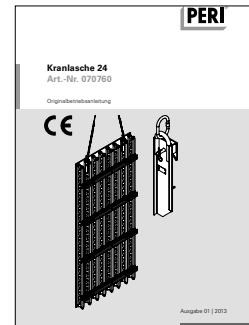

Fig. B2.06



Preparation for initial assembly

1. Completely move back the sliding block (16.2) of the Adjusting Unit CB, SW 19, see B3.
2. Fix Strongback CB (70) to the Adjusting Unit CB by means of Bolts $\varnothing 25 \times 180$ (73) and Cotter Pins 4/1.
3. Attach Adjustable Brace (44) to Strongback CB (70) using Bolts $\varnothing 25 \times 180$ and Cotter Pins 4/1 and laterally brace the Strongbacks. $\varnothing 25 \times 180$ and Cotter Pins 4/1 and laterally brace the Strongbacks.

Assembly

4. Check that the Height Adjusting Unit CB, SCS (72) is in the correct position and adjust if necessary.
5. Lower formwork (78) with the bottom waler (78.1) onto the Height Adjusting Unit CB, SCS. Lifting gear remains tensioned.
6. Mount Waler Fixation U100 – U120 (71) on the walers. (Fig. B2.07)
7. Detach lifting gear.
8. Turn sliding block (16.2) in the Adjusting Unit CB to the wall, SW 19.
9. Align formwork, see B3. (Fig. B2.08)



Attention must be paid to ensure that the Strongback does not collide with the Scaffold Bracket GB 80 (77) or decking (31). If necessary, re-position Scaffold Bracket GB 80 and form recess in the decking.

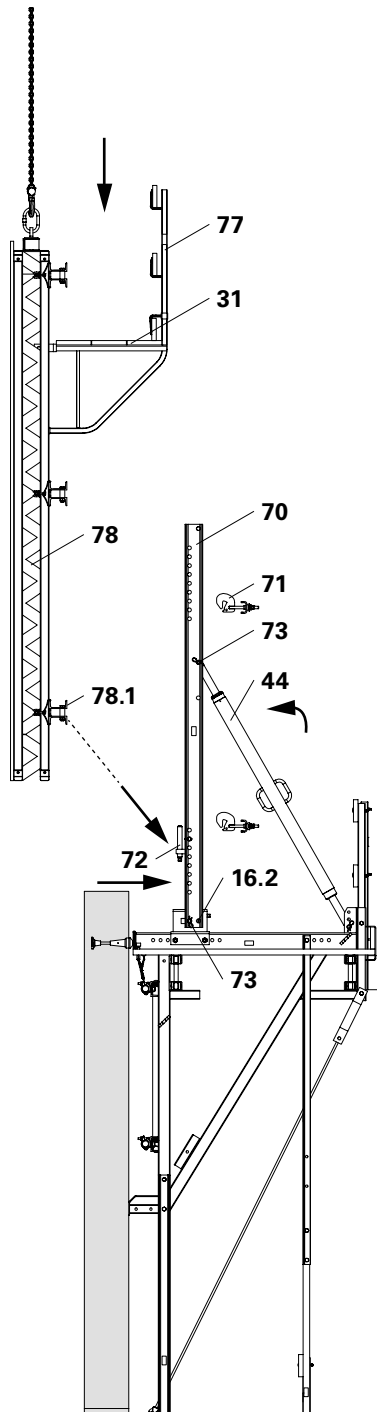

Fig. B2.07

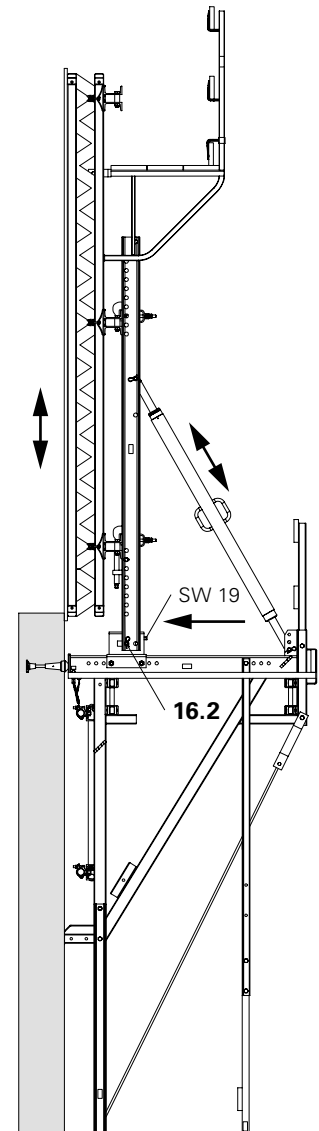

Fig. B2.08

TRIO/MAXIMO Panel with Adapter TRIO-CB

Mounting of Strongback CB on TRIO Panel

1. Assemble TRIO Panels on the assembly area to form formwork units.
2. Fix Connectors TRIO-CB (79) to panel struts using hook clamps $\varnothing 25$ (79.1), see plans for arrangement. Centre distance = bracket spacing.
By changing the mounting position of the spindle (79.2), the Connector TRIO-CB can be used cantilevering on the left or right.
(Fig. B2.09 + B2.10)
3. Place Strongback CB (70) on the connectors. Bottom projecting length: see plans or C1.
4. Attach Strongback CB (70) to bottom connector using Bolts $\varnothing 25 \times 180$ (73) and Cotter Pins 4/1.
5. Adjust height on bottom connector using the spindle (79.2).
6. Adjust height of top connector.
7. Fix Strongback CB (70) to the top Connector TRIO-CB. (Fig. B2.15)

Connector TRIO-CB left cantilevering

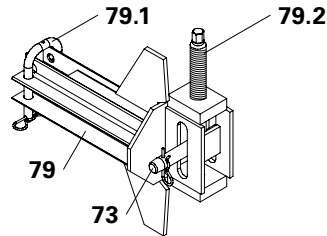

Fig. B2.09

right cantilevering

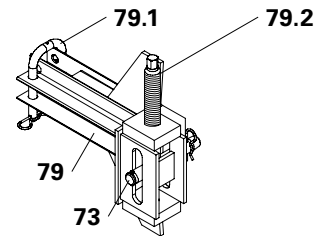

Fig. B2.10

Use on horizontal struts

left cantilevering

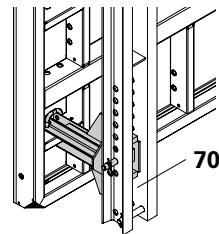

Fig. B2.11

right cantilevering

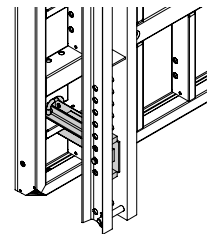

Fig. B2.12

Use on vertical struts

left cantilevering

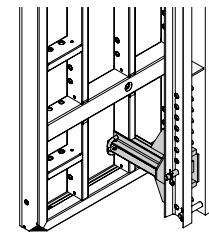

Fig. B2.13

right cantilevering

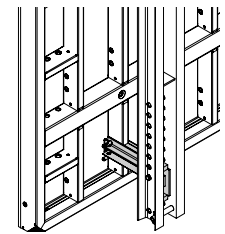

Fig. B2.14



Fig. B2.15



In order to prevent the Strongbacks being pulled out of position at any time, timber (74) is clamped between the top ends of the Strongbacks, see also C1 Moving.

(Fig. B2.16)



Alternatively, use Lifting Beam RCS 10 t (Item no. 112986) for moving.

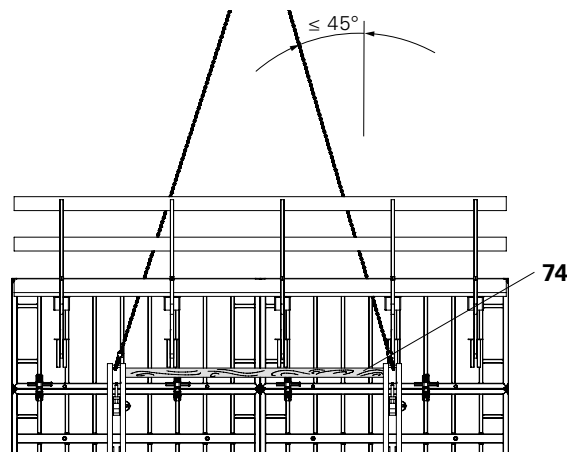

Fig. B2.16

Mounting of a formwork panel on the Bracket CB 160

1. Completely move back the sliding block (16.2) of the Adjusting Unit CB (16), SW 19. (Fig. B2.17a)
2. Open concreting platform decking (31) above the Strongback. Secure loose decking components.
3. Attach formwork (78) together with concreting platform to the Strongback CB (70), and position on the platform. (Fig. B2.17b)
4. Fix Strongback to the Adjusting Unit CB (16) by means of Bolts \varnothing 25x180 (73) and Cotter Pins 4/1. Standard case: use those holes in the Strongback facing the wall. (Fig. B2.17b)

5. Fix Adjustable Brace CB 164-224 (44) to the bracket using Bolts \varnothing 25 x1 80 (73) and Cotter Pins 4/1. Spindle out to approx. length and attach to Strongback CB (70). (Fig. B2.17c)
6. Detach lifting gear. Close decking (31) on the concreting platform.
7. Turn sliding block (16.2) of the Adjusting Unit CB with formwork to the wall, SW 19. (Fig. B2.17d)
8. Align formwork, see B3. (Fig. B2.17d)



For a controlled moving procedure of the units, always use a guide rope.

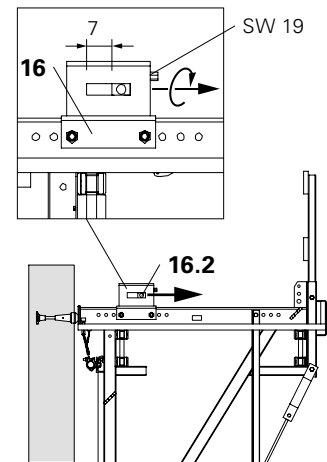

Fig. B2.17a

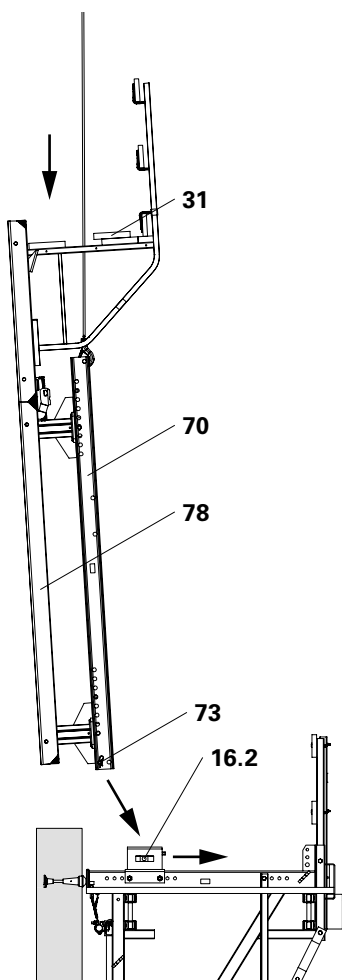

Fig. B2.17b

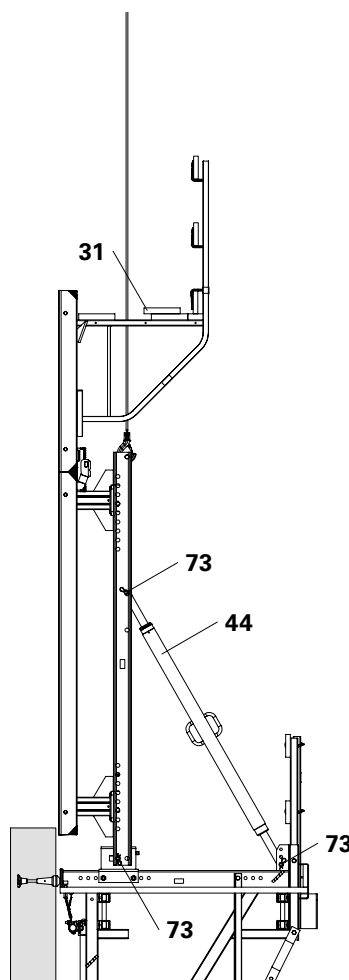

Fig. B2.17c

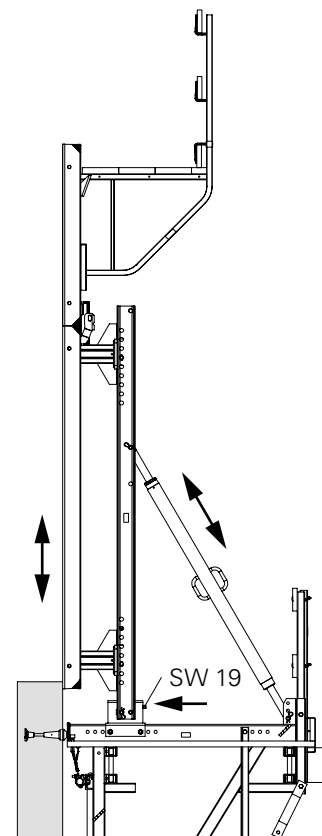

Fig. B2.17d

CB 160 Climbing Formwork

Instructions for Assembly and Use – Standard Configuration

Exchanging the formwork panels



**Follow Instructions for Use:
Lifting Hook MAXIMO 1.5 t!**

Dismantling

1. Move back the sliding block (16.2) in the Adjusting Unit CB, SW 19. Laterally brace the Strongbacks.
2. Fix Lifting Hook MAXIMO 1.5 t (80) to the formwork unit (78) and then attach lifting gear.
3. Tension crane lifting gear.
4. Release bail \varnothing 25 (79.1) of the Connectors TRIO-CB (79).
5. Raise formwork and remove (e.g. storage area). (Fig. B2.18)



When laying the formwork down, the handrail boards (19) of the Scaffold Bracket TRG (81) must be removed (by the contractor) in order to avoid any damage caused by the crane lifting gear.

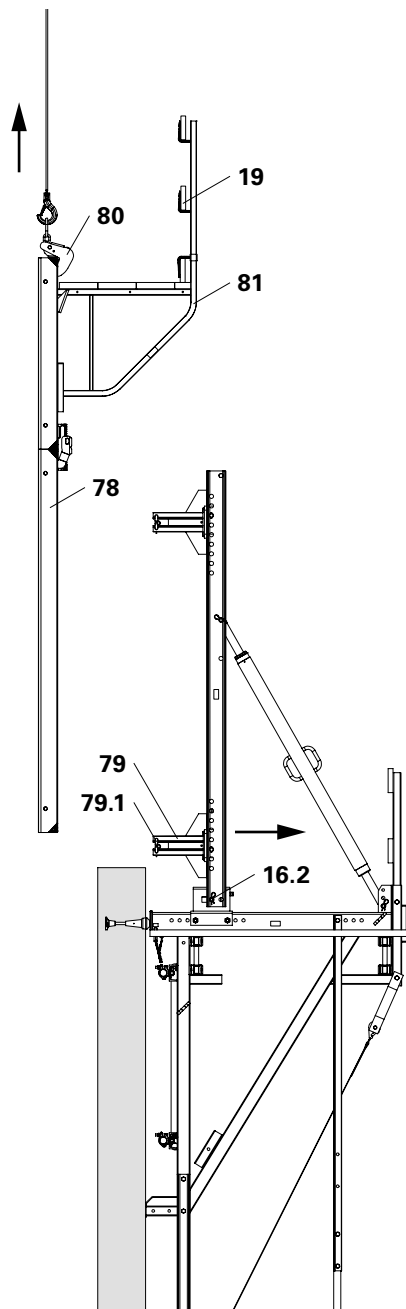
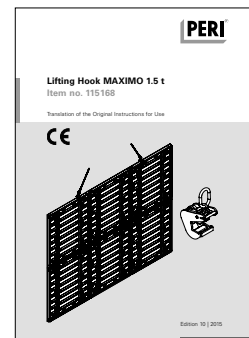

Fig. B2.18



Preparation for initial assembly

1. Completely move back the sliding block (16.2) of the Adjusting Unit CB, SW 19, see B3.
2. Fix Connectors TRIO-CB (79) to the Strongback CB (70) using Bolts \varnothing 25x180 (73) and Cotter Pins 4/1.
3. Fix Strongback CB to the Adjusting Unit CB by means of Bolts \varnothing 25x180 (73) and Cotter Pins 4/1. \varnothing 25x180 (73) and Cotter Pins 4/1.
4. Fix Adjustable Brace CB 164-224 (44) to the bracket and Strongback CB using Bolts \varnothing 25x180 (73) and Cotter Pins 4/1.
5. Brace Strongbacks laterally. (Fig. B2.19)

Assembly

6. Insert formwork (78) with Lifting Hook MAXIMO 1.5 t (80) into the Connectors TRIO-CB (79) and secure using bail \varnothing 25 (79.1).
7. Remove crane lifting gear and lifting hook.
8. Turn sliding block (16.2) in the Adjusting Unit to the wall, SW 19.
9. Align formwork, see B3. (Fig. B2.20)



Attention must be paid to ensure that the Strongback CB does not collide with the TRIO Scaffold TRG (81) or decking (31). If necessary, re-position Scaffold Bracket and form recess in the decking.



Check the clearance of the top height adjustment, ≥ 5 mm.

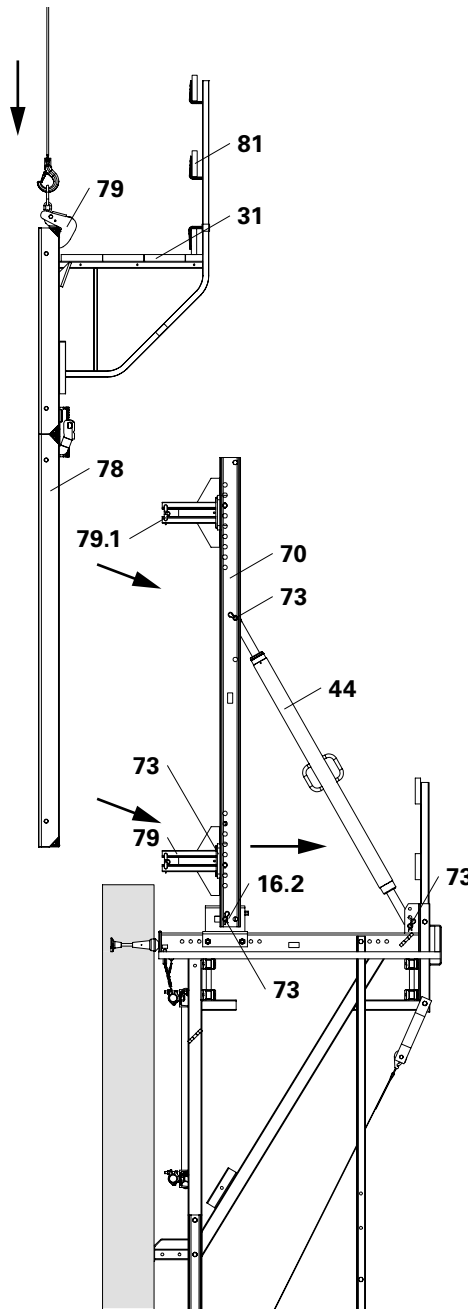

Fig. B2.19

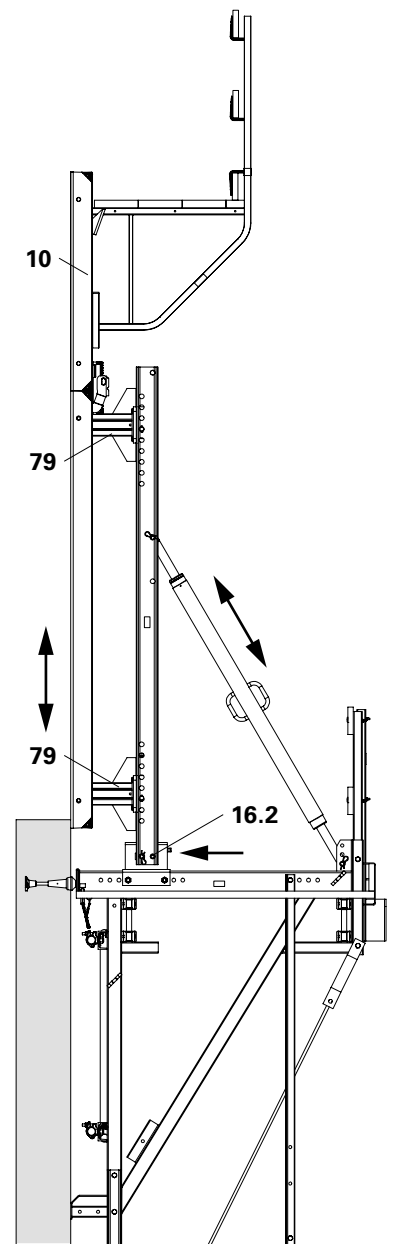

Fig. B2.20

TRIO/MAXIMO Panel with Formwork Waler 150 CB



For static reasons, the U-Profile of the Formwork Waler 150 CB must be pointing upwards when using Push-Pull Prop Connector CB (Fig. B2.25a)



The Formwork Waler 150 CB (83) is attached to the Clamp Adapter MX / TR – SRU (84) as standard by means of the Tie Rod DW 15 (84.4) and Wingnut Counterplate DW 15 (84.3). (Fig. C1.16a) If the Wingnut Counterplate DW 15 (84.3) collides with the Strongback, the Clamp Adapter MX / TR – SRU (84) can be secured using Fitting Pins Ø 21 x 120 (84.2) and Cotter Pins 4/1.

Formwork Waler 150 CB

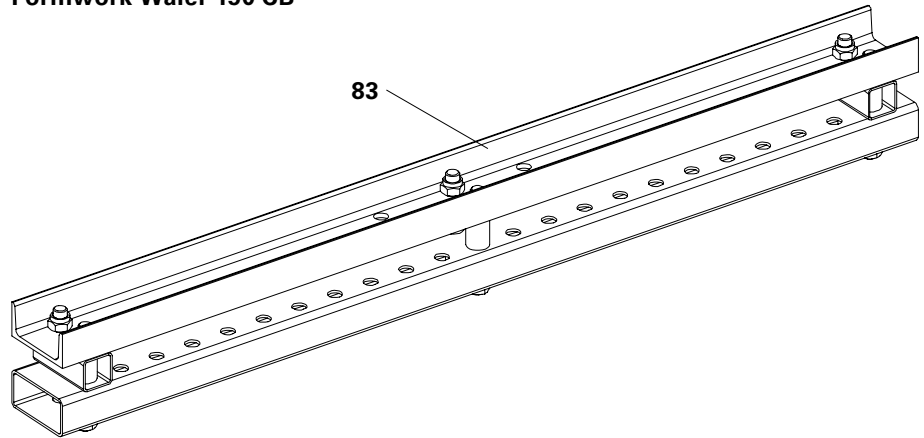

Clamp Adapter MX / TR – SRU

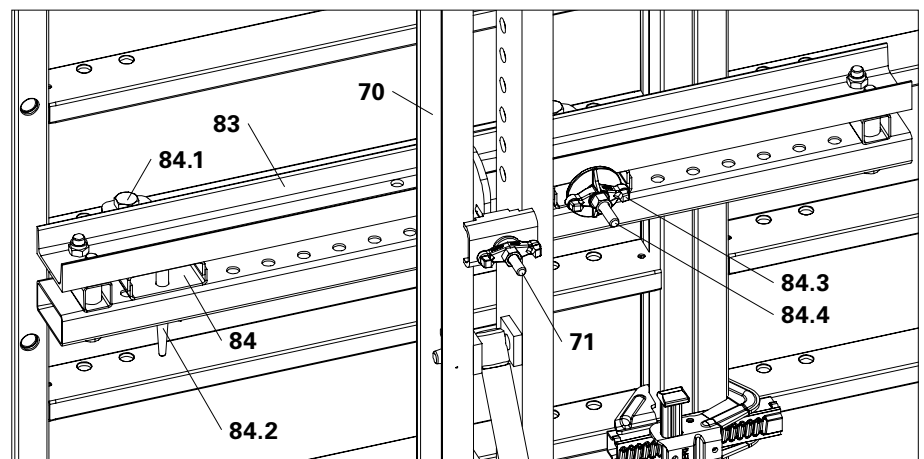
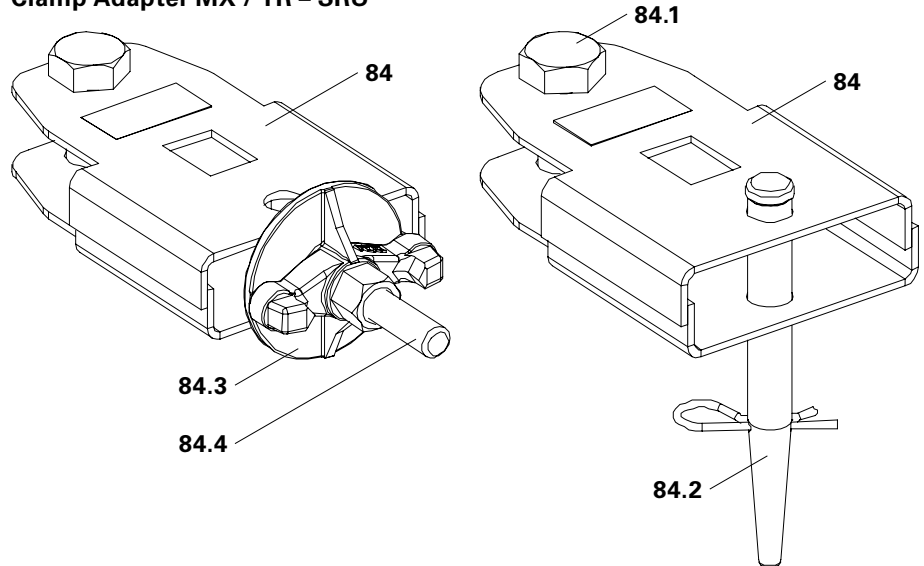

Fig. B2.21

Assembly of Formwork Waler 150 CB on the TRIO/MAXIMO Panel

1. Assemble TRIO/MAXIMO Panels on the assembly area to form formwork units.
2. Fix 2x Clamp Adapter MX / TR – SRU (84) to the formwork using Bolts ISO 4014 M24 x 80-8.8 (84.1) and Nuts ISO 4032 M24-8.
3. Place the Formwork Waler 150 CB (83) with U-profile pointing upwards on the Clamp Adapter MX / TR-SRU when using Push-Pull Prop Connector CB (84).
4. Brace the Formwork Waler 150 CB (83) on the formwork using the Tie Rod DW 15 (84.4) and Wingnut Counterplate DW 15 (84.3). Alternatively: mount Formwork Waler 150 CB on the Clamp Adapter MX / TR – SRU using Fitting Pins $\varnothing 21 \times 120$ (84.2) and secure with Cotter Pins 4/1.
5. Position the Strongback (70) on the Formwork Waler 150 CB (83) according to the bracket spacing, and secure. Bottom projecting length: see plans or C1. (Fig. B2.01)
6. Mount Waler Fixation U100 – U120 (71) and secure in position by tightening the Quick Jack Nut.
7. Fix Height Adjusting Unit CB, SCS (72) with Bolts $\varnothing 25 \times 180$ (73) and Cotter Pins 4/1 to the Strongback CB (70). (Fig. B2.03)
8. Turn the spindle (72.1) of the Height Adjusting Unit against the Formwork Waler. (Fig. B2.26)



Does the U-profile of the Formwork Waler 150 CB point upwards?
(Fig. B2.25a + B2.25b)

Does the Formwork Waler 150 CB rest against the vertical profiles of the formwork?

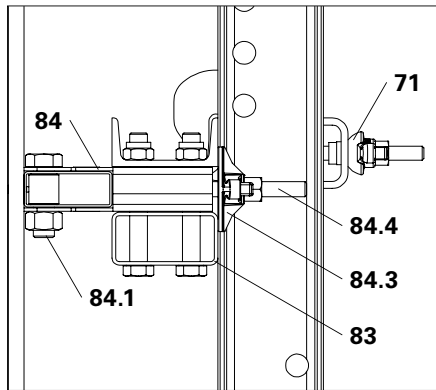

Fig. B2.22a

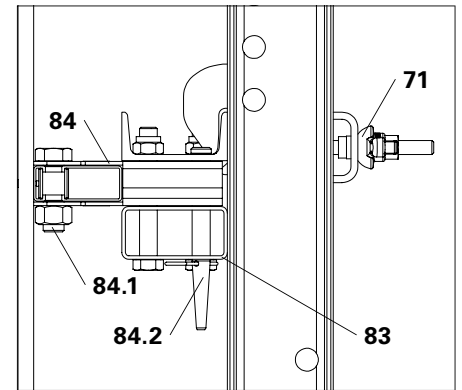

Fig. B2.22b

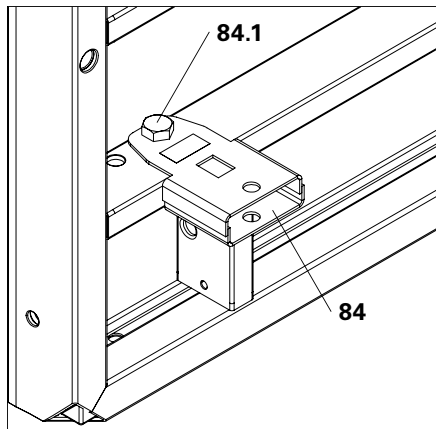

Fig. B2.23

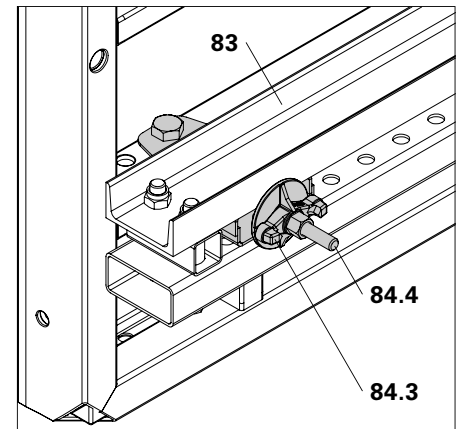

Fig. B2.24

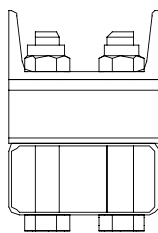

Fig. B2.25a

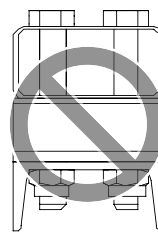

Fig. B2.25b



The spacing between the bottom edge of the Formwork Waler 150 CB (83) and the bottom edge of the Strongback (70) is 40.9 cm.

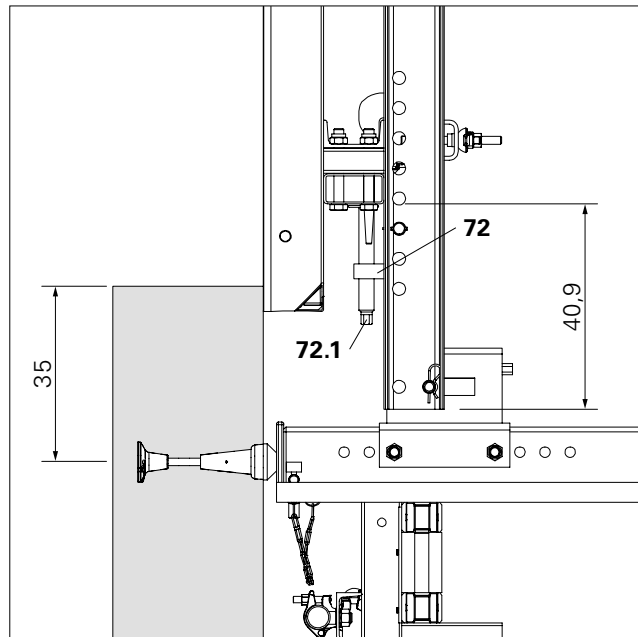

Fig. B2.26



In order to prevent the Strongbacks being pulled out of position at any time, timber (74) is clamped between the top ends of the Strongbacks, see also C1 Moving.

(Fig. B2.27)

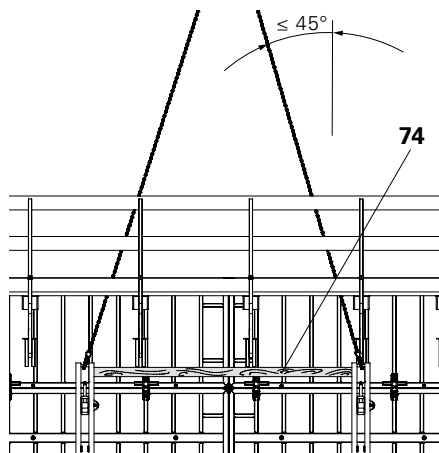

Fig. B2.27



Alternatively, use Lifting Beam RCS 10 t (Item no. 112986) for moving.

Mounting of a formwork panel on Bracket CB 160

1. Completely move back the sliding block (16.2) of the Adjusting Unit CB (16), SW 19. (Fig. B2.28a)
2. Open concreting platform decking (31) above the Strongback. Secure loose decking components.
3. Attach formwork (78) together with concreting platform to the Strongback CB (70), and position on the platform. (Fig. B2.28b)
4. Fix Strongback to the Adjusting Unit CB (16) by means of Bolts $\varnothing 25 \times 180$ (73) and Cotter Pins 4/1. Standard case: use those holes in the Strongback which face away from the wall. (Fig. B2. 28b)
5. Fix Adjustable Brace CB 164-224 (44) to the bracket using Bolts $\varnothing 25 \times 180$ (73) and Cotter Pins 4/1. Spindle out to approx. length and attach to Strongback CB (70). (Fig. B2.28c)
6. Detach crane lifting gear. Close decking (31) on the concreting platform.
7. Turn sliding block (16.2) of the Adjusting Unit CB with formwork to the wall, SW 19.
8. Align formwork, see B3. (Fig. B2.28d)



For a controlled moving procedure of the units, always use a guide rope.

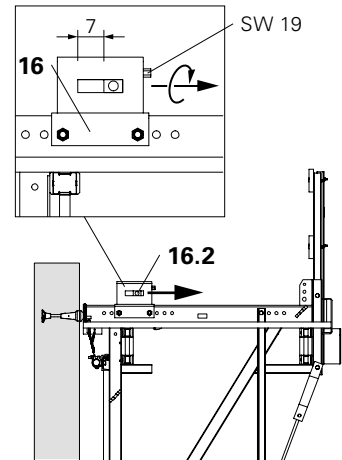

Fig. B2.28a

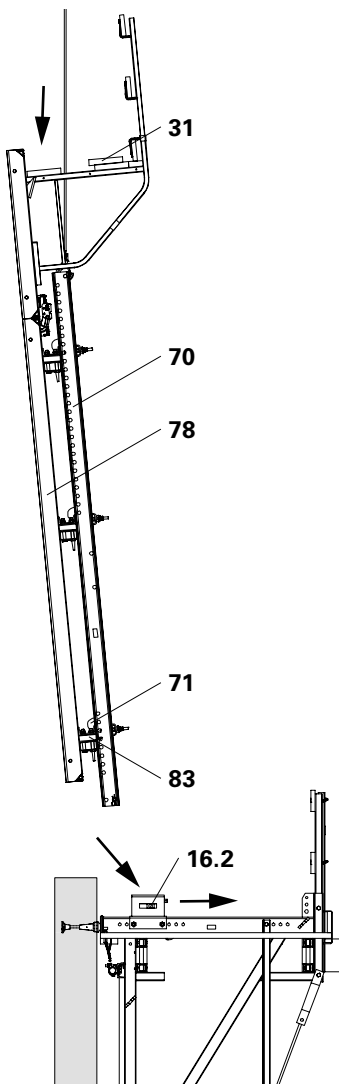

Fig. B2.28b

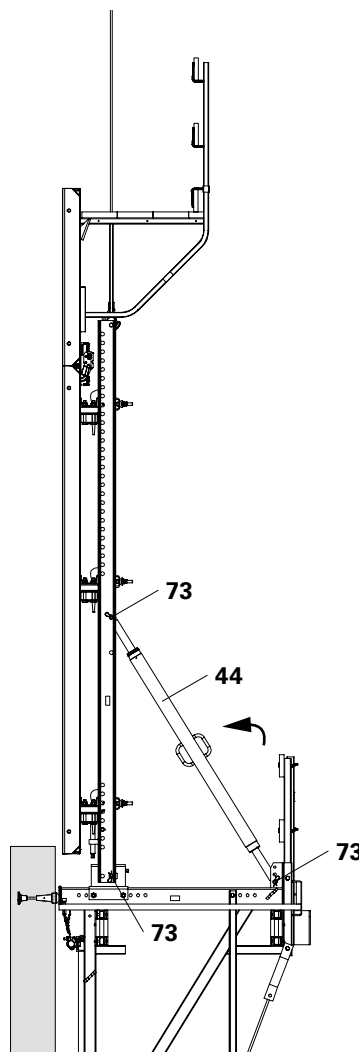

Fig. B2.28c

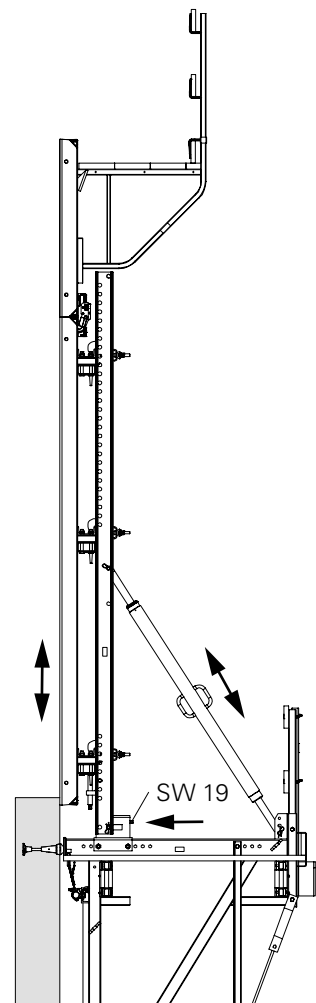

Fig. B2.28d

CB 160 Climbing Formwork

Instructions for Assembly and Use – Standard Configuration

Exchanging the formwork panels



Follow Instructions for Use: Lifting Hook MAXIMO 1.5 t!

Dismantling

1. Move back the sliding block (16.2) in the Adjusting Unit CB, SW 19. Laterally brace the strongbacks.
2. Fix Lifting Hook MAXIMO 1.5 t (80) to the formwork unit (78) and then attach crane lifting gear.
3. Tension crane lifting gear.
4. Remove all Waler Fixations U100 – U120 (71).
5. Raise formwork and remove (e.g. storage area). (Fig. B2.29)



When laying the formwork down, the handrail boards (19) of the Scaffold Bracket TRG (81) must be removed (by the contractor) in order to avoid any damage caused by the crane lifting gear.

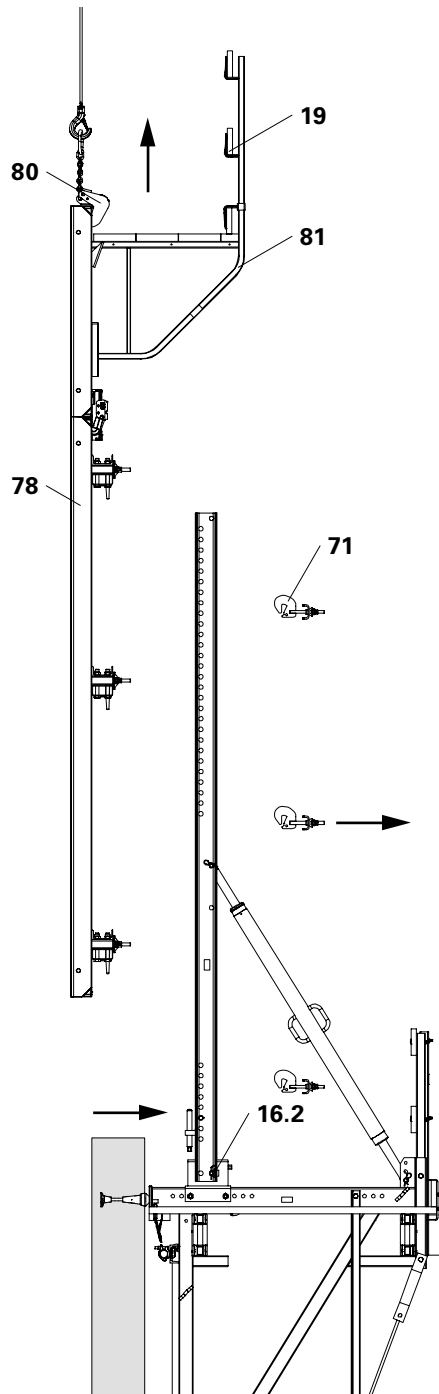
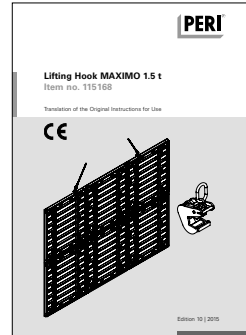

Fig. B2.29



Preparation for initial assembly

1. Completely move back the sliding block (16.2) of the Adjusting Unit CB, SW 19, see B3.
2. Fix Strongback CB to the Adjusting Unit CB by means of Bolts \varnothing 25x180 (73) and Cotter Pins 4/1.
3. Fix Adjustable Brace CB 164-224 (44) to the bracket and Strongback CB using Bolts \varnothing 25x180 (73) and Cotter Pins 4/1.
4. Brace strongbacks laterally. (Fig. B2.30)

Assembly

5. Check that the Height Adjusting Unit CB, SCS (72) is in the correct position, and adjust if necessary.
6. Lower formwork (78) with the Formwork Walers 150 CB (83) onto the Height Adjusting Unit CB, SCS. Crane lifting gear remains tensioned.
7. Mount Waler Fixation U100 – U120 (71) on the walers. (Fig. B2.07)
8. Detach crane lifting gear.
9. Turn sliding block (16.2) in the Adjusting Unit CB to the wall, SW 19.
10. Align formwork, see B3. (Fig. B2.31)



Attention must be paid to ensure that the Strongback CB does not collide with the TRIO Scaffold TRG (81) or decking (31). If necessary, re-position Scaffold Bracket and form recess in the decking.

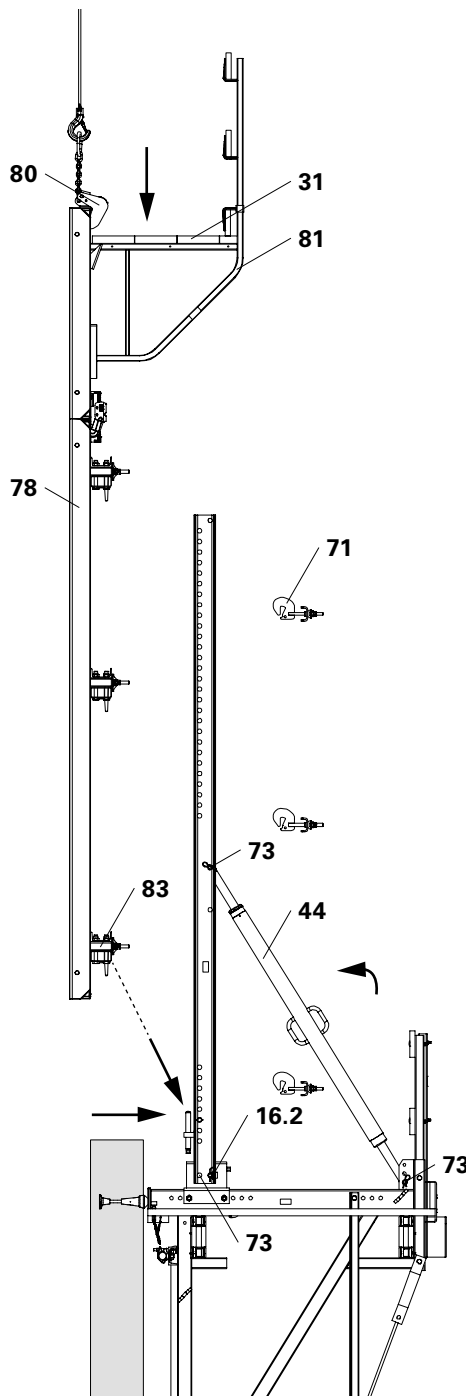

Fig. B2.30

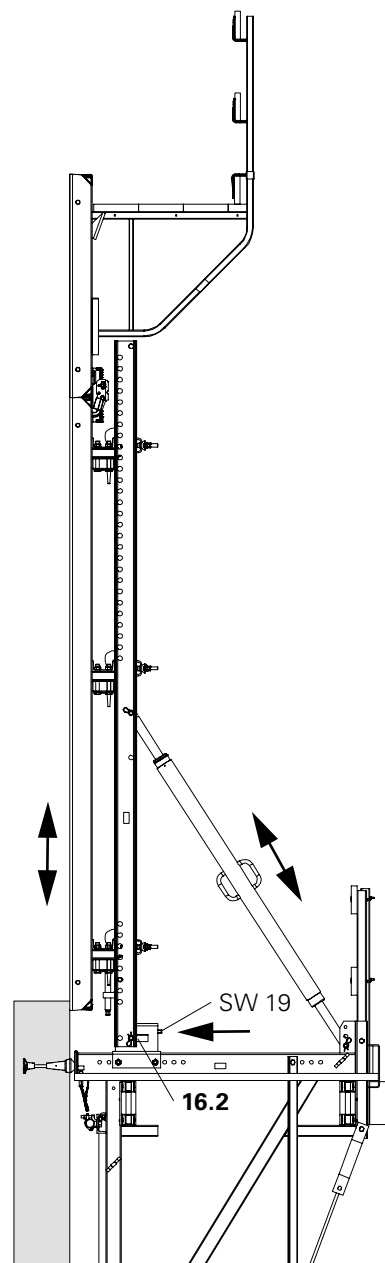

Fig. B2.31

Utilisation of Adjusting Unit CB 160

Adjusting Unit

- Adjusting Unit CB 160 (16)
- Sliding block with hole Ø 26 (16.2)
- Adjusting Bolt SW 19 (16.1)
- Bolt ISO 4014 M20 x 150-8.8 (17)
- Nut ISO 7042 M20-8 (2x)
- Ratchet Lever SW 19 (82)
- (Fig. B3.01)

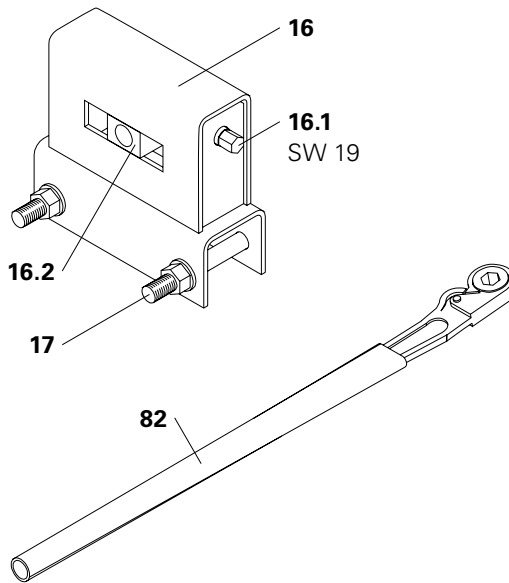

Fig. B3.01



After using the Adjusting Unit, the inclination of the formwork must be checked and adjusted.

Moving the formwork to the wall

Turn the Adjusting Bolt SW 19 (16.1) in an anti-clockwise direction. The sliding block (16.2) then moves to the wall.
(Fig. B3.02)
Adjusting range: max. 7 cm.

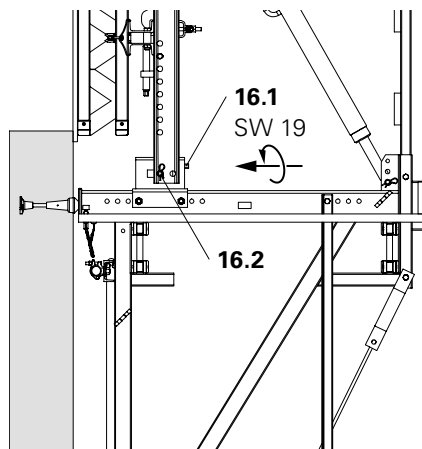

Fig. B3.02

Moving the formwork away from the wall

Turn the Adjusting Bolt SW 19 (16.1) in a clockwise direction. The sliding block (16.2) then moves away from the wall.
(Fig. B3.03)

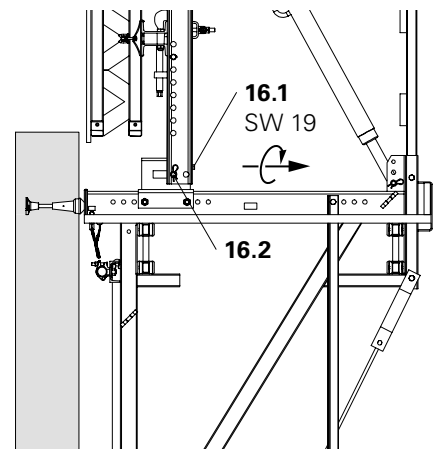

Fig. B3.03

Alignment of the formwork

Height adjustment with the Connector TRIO-CB

1. On the top Connector, alter the adjusting spindle (79.2) for the necessary clearance.
2. On the bottom Connector, lower the adjusting spindle (79.2) onto the Bolts $\text{Ø } 25 \times 180$ (73). (Fig. B3.05)
3. Turn the adjusting spindle (79.2) using Ratchet Lever SW 19 (82) and bring formwork into position.
4. Turn top Connector TRIO-CB (79) back to stop.

Depending on the rotational direction, the formwork moves upwards or downwards. (Fig. B3.04)



- Is there enough clearance for adjustment on the top Connector?
- By placing a spirit level on a strut in the formwork panel, exact adjustment is possible.



Fig. B3.04

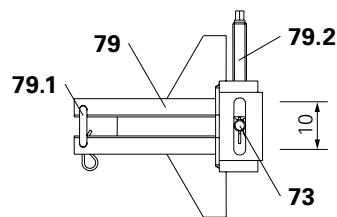

Fig. B3.05

Height adjustment with the Height Adjusting Unit CB, SCS

1. If necessary, release the top Height Adjusting Unit CB, SCS (72) and adjust to achieve the required clearance.
2. Apply Ratchet Lever SW 19 (82) to adjusting spindle (72.1) of the Height Adjusting Unit CB, SCS (72) on the Strongback. Depending on the rotational direction, the formwork moves upwards or downwards.
3. If necessary, turn top Height Adjusting Unit CB, SCS (72) back to stop. (Fig. B3.06 + B3.07)

Permissible load: see C1.



- If the formwork does not move, loosening the Waler Fixation U100 – U120 (71) will make the adjustment easier.
- By placing a spirit level on the formwork waler line (78.1), exact adjustment is possible.

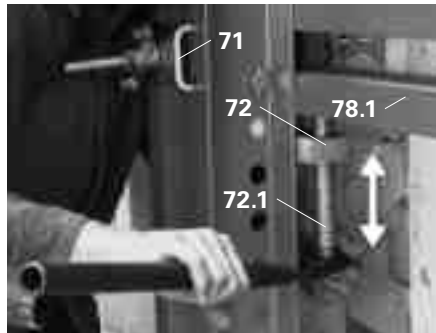

Fig. B3.06

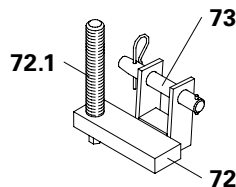

Fig. B3.07

Inclination adjustment with the Adjustable Brace CB 164-224

The required inclination of the formwork is achieved by adjusting the Adjustable Brace CB 164-225 (44).

Depending on the rotational direction, the formwork moves forward or retracts.

(Fig. B3.08)



By placing a spirit-level on the TRIO formwork struts or on a VARIO formwork girder, exact adjustment is possible.
(Fig. B3.08)



Fig. B3.08

44

Horizontal movement of a VARIO Panel with Waler Fixation

1. Loosen the Waler Fixation U100 – U120 (71) until the panel can be moved.
2. Move the panel into the correct position by hand or by using a piece of timber as a lever.
3. Tighten the Waler Fixation. (Fig. B3.09)



Strongbacks must remain in the same position.

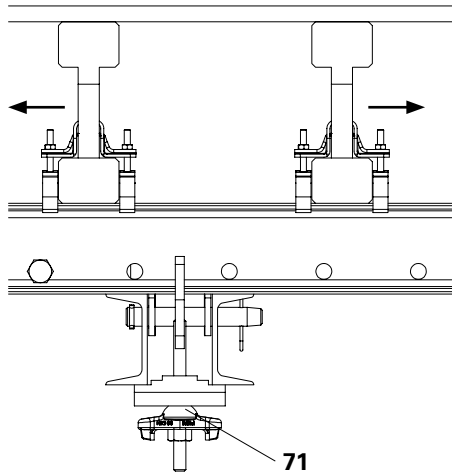

Fig. B3.09

Horizontal movement of a TRIO/ MAXIMO Panel with a Formwork Waler 150 CB

1. Loosen the Waler Fixation U100 – U120 (71) until the panel can be moved.
2. Move the panel into the correct position by hand or by using a piece of timber as a lever.
3. Tighten the Waler Fixation. (Fig. B3.10)



Strongbacks must remain in the same position.

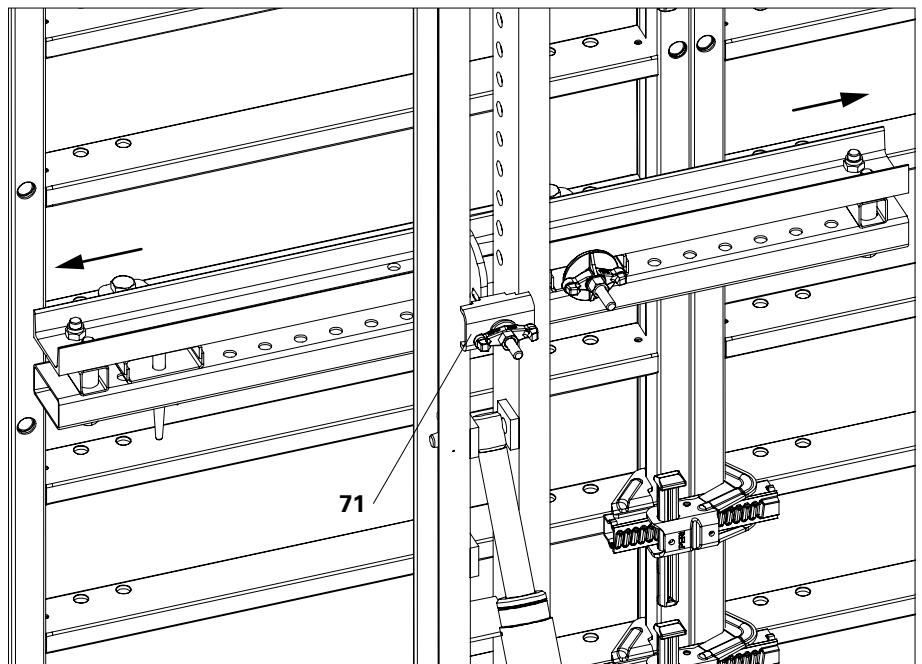

Fig. B3.10

Preparation



Do not exceed the crane capacity!

1. Loosen tie points and remove tie rods.
2. Move formwork away from the wall using the Adjusting Unit CB (16), see B3. Tilt formwork towards the guardrails using the Adjustable Brace CB 164-224 (44).
3. Mount Scaffold Mounting Ring M24 (45) on the next concreting section using Bolts ISO 4014 M24 x 120-10.9 (46), see B1 Anchoring.
4. Detach wind bracing from the wall using Tie Rod DW 15 (33) or Tension Belt L = 5.70 m, 2.5 t (55) and lay it down on the finishing platform.
5. Remove mounting parts of the wind bracing.
6. Remove cones (34/37) which are no longer required, see B1.
7. Brace Strongback CB (70), e.g. with timber, see C1 Moving.
8. Open concreting platform decking (31) above the Strongback. Secure loose parts. Attach moving unit to the Strongback CB (70). (Fig. B4.01)
9. Pull out securing pins (6.4). (Fig. B4.01a)
10. All personnel must leave the moving unit.

The unit is now ready to be moved.



If the crane capacity is insufficient, the formwork and platform can be moved separately. For this, refer to B2 and B1.



- Have the securing pins been completely removed?
- Is the locking device on the lifting hook closed?
- Is the crane sling angle correct?
- Are the guardrail posts secured with bolts?
- Have loose parts been removed?

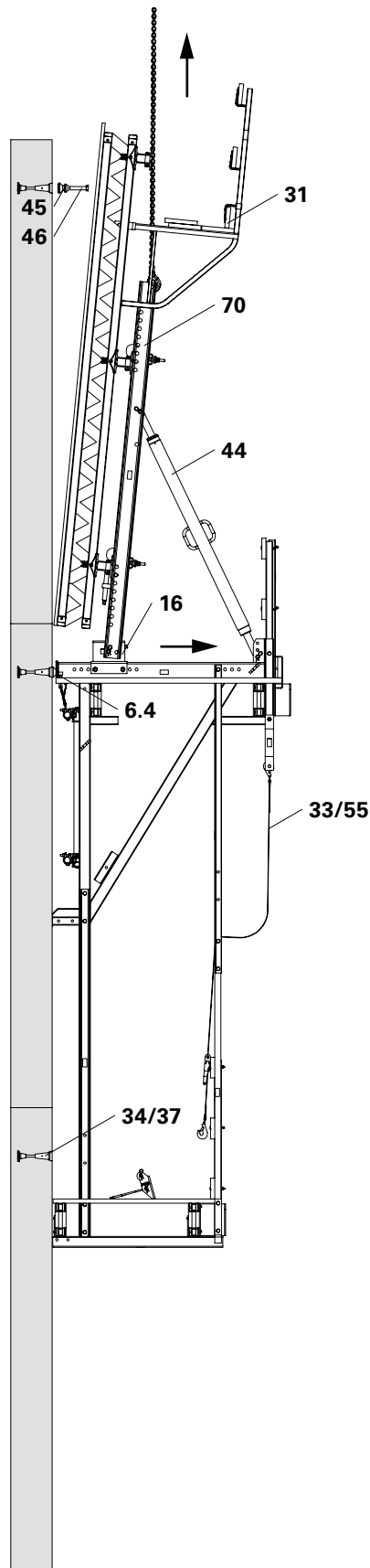

Fig. B4.01

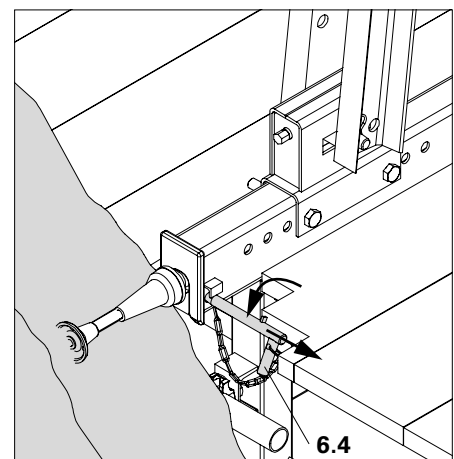

Fig. B4.01a

Moving procedure



- For moving the climbing unit with widened crane lifting gear, install timber (74) as a compression brace between the Strongbacks CB.
- Do not exceed the permissible load-bearing capacity.



Do not attach the climbing unit to the formwork.

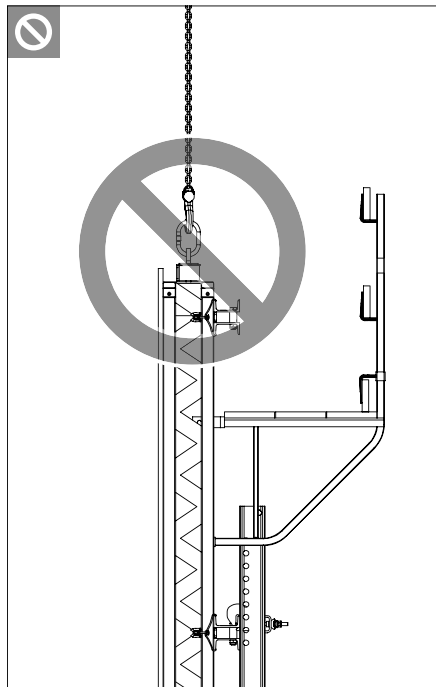

Fig. B4.02a

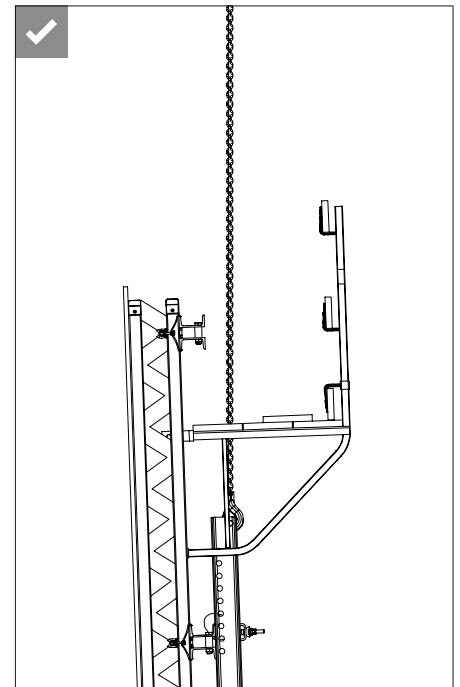

Fig. B4.02b

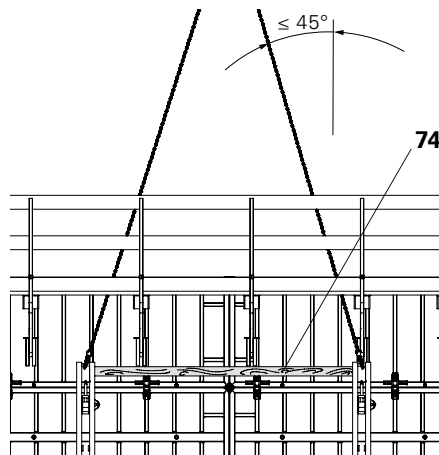

Fig. B4.02c



Use a guide rope to ensure controlled movements of the platform when being moved. Any leading edges created during the climbing procedure are to be made safe or cordoned off. Loose components are to be secured or removed before moving takes place.



Attachment points for ropes and personal protective equipment to prevent falling are the holes on the Strongback CB (70) or additionally inserted Bolts $\varnothing 26 \times 120$ on the Strongback.

Moving

1. Crane lifts the moving unit out of the Scaffold Mounting Ring M24 (45a).
2. Crane lifts the moving unit up to the next Scaffold Mounting Ring M24 (45b).
3. Bring platform into position.
4. Lower the moving unit onto Scaffold Mounting Ring M24 (45b) evenly and without tilting until the lower points of pressure (6.7) of the bracket rest against the wall. Crane lifting gear remains tensioned. (Fig. B4.03a – B4.03d)

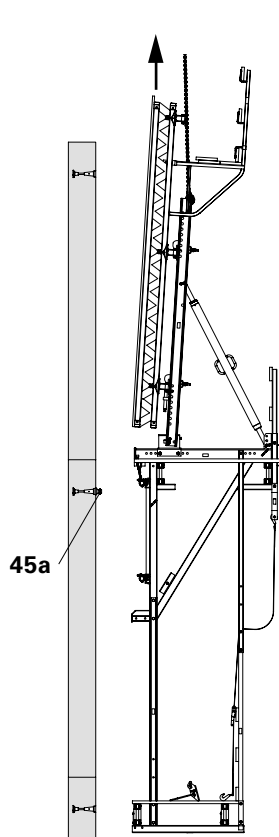

Fig. B4.03a

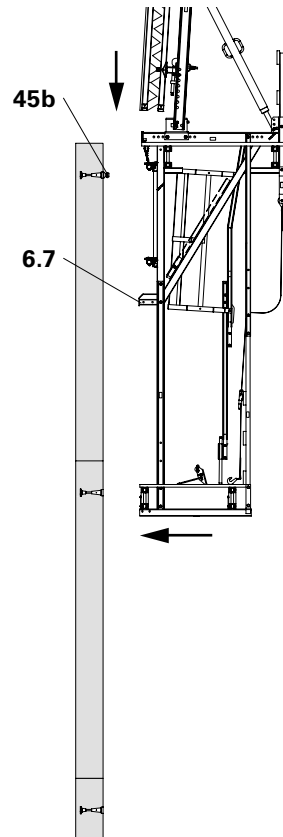

Fig. B4.03b

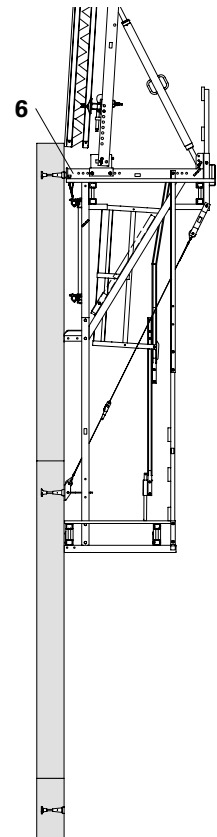

Fig. B4.03c



Are the Climbing Brackets CB 160 (6) attached to both Scaffold Mounting Rings M24 (45)?

Troubleshooting

- If no connection is made with the Scaffold Mounting Rings M24 (45) or if the Climbing Brackets CB 160 (6) jam, lift the platform and lower it again.
- If the bracket spacing does not match that of the Scaffold Mounting Rings, check the distance of the leading anchors on the formwork.
- If the mounting procedure is not possible, the bracket spacing must be corrected through the re-assembly of the platform.

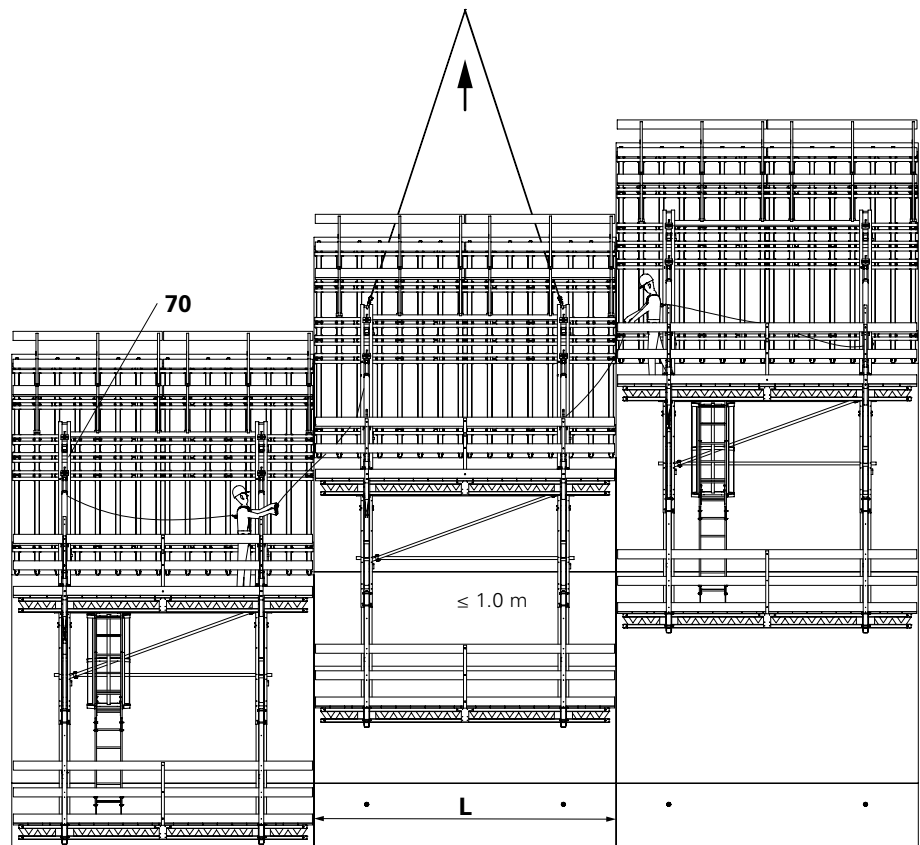

Fig. B4.03d

Securing the moving unit



If the securing pins cannot be inserted, repeat the procedure!

1. Access platform.
2. Insert securing pins (6.4) under the Scaffold Mounting Ring M24 (45). (Fig. B4.04 – B4.04a)
Use cut-out in the planking (31).
3. Remove crane hook.
4. Close decking (31) on the concreting platform.

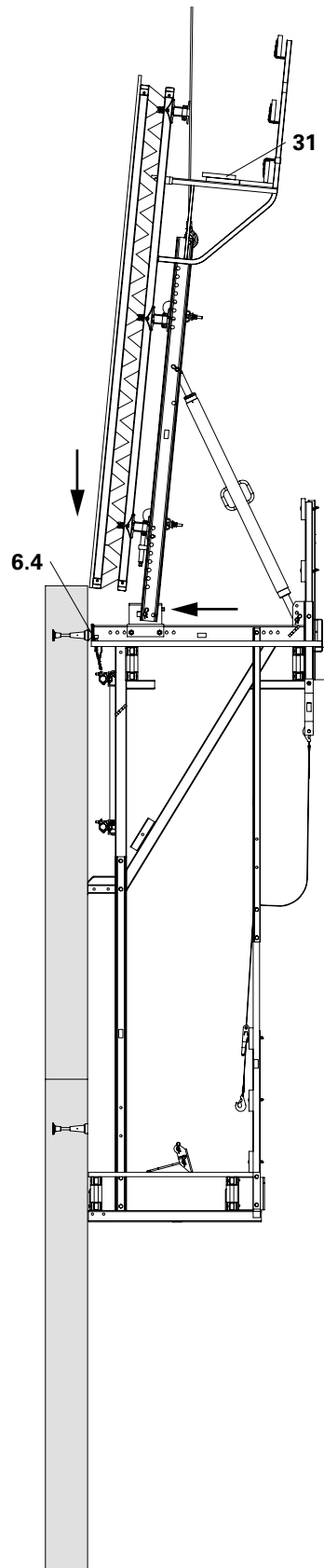

Fig. B4.04

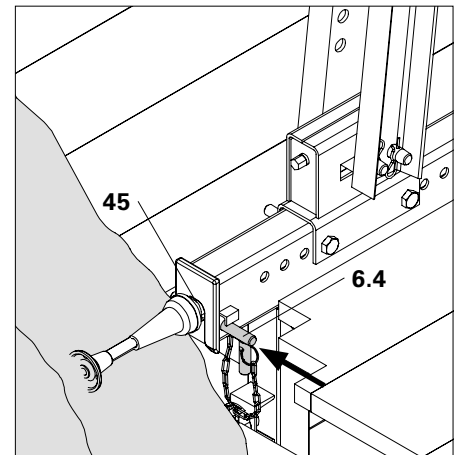

Fig. B4.04a

C1 Planning and work preparation for the platforms

Drawings and plans

Assembly drawings

The following points at least should be featured in the assembly drawings:

- bracket spacing and bracing
- dimensions of the working and finishing platforms
- dimensions, arrangement and number of concreting and intermediate platforms
- configuration of girders and ladder safety cages
- layout of end guardrail posts
- layout of lateral guardrails
- position of access ladders
- material requirements (parts lists)

General arrangement drawings

The following points at least should be featured in the general arrangement drawings:

- position of the climbing anchor in the plan view and sectional view
- which scaffolding platform is used on which part of the building
- associated formwork and finishing platform
- installation of wind bracing
- distance of finishing platform to the working platform
- formwork-strongback connection points
- compression brace position between the strongbacks
- reference values for the retraction distance during moving
- possible special measures in case of irregular concreting heights
- modification details
- material requirements (parts lists)



Appropriate, easy-to-read as well as sufficient drawings in both number and format are to be made available to the site management. The drawings are to be created clearly and professionally in the language of the country where construction is taking place.



PERI recommends:

- a plan view and sectional view of the scaffold as well as an overview plan for positioning purposes.
- a plan view and a top view of the platforms.

Identification markings



PERI recommends that each platform be distinctly marked and a document be created with the following data:

- Company name
- Construction site
- Name and contact details of the planner
- Marking in accordance with the plans
- Dimensions
- Weight of the unit with formwork
- Weight of the unit without formwork
- Maximum formwork height
- Permissible live loads

C1 Planning and work preparation for the platforms

Platform decking



Observe national laws and regulations at all times.



- Platform decking is in accordance with DIN EN 12811 and DIN 4420-1.
 - Tripping hazards, unnecessary box outs and openings in the decking are to be avoided or covered.
 - The distance between the decking and the structure should be max. 5 cm.
 - Gaps between the planking must not exceed 2 cm.
 - The spacing between the decking of adjacent platforms must not exceed 2 cm. Larger gaps are to be covered with non-movable suitable materials or safety nets (68) with a max. mesh size of 2 cm are to be used.
 - Any openings in the decking, which are required for normal working procedures, must be covered with non-movable suitable materials.
 - Safe working conditions for tie operations are to be provided through the arrangement of intermediate platforms.
 - For circular structures, take additional measures in accordance with the given radius.
 - Plan the corner platforms so that accessing one platform from another can be done safely.
 - Access routes and construction procedures must also ensure that safe escape routes are available at all times.
 - Minimum dimensions of planking: see Table 1.
 - Permissible span of girders: see Table 2.
- (Fig. C1.01)

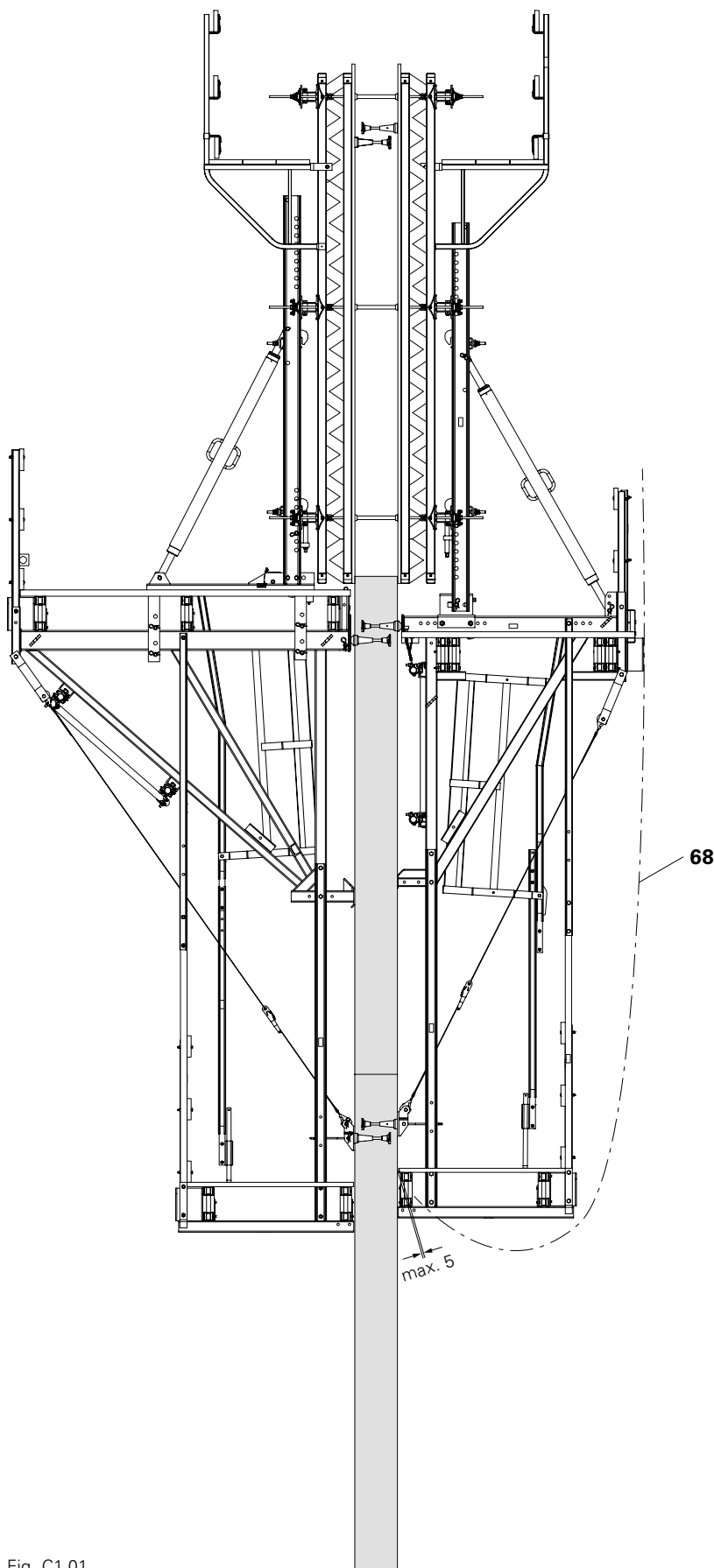

Fig. C1.01

C1 Planning and work preparation for the platforms

Layout of main platform – when used as formwork scaffold

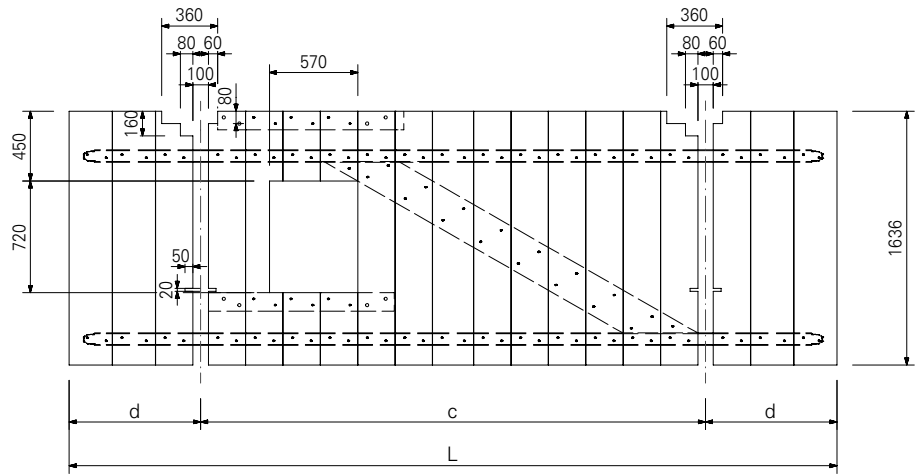

Fig. C1.02a

Layout of main platform – when used as working scaffold (Platform above the bracket)

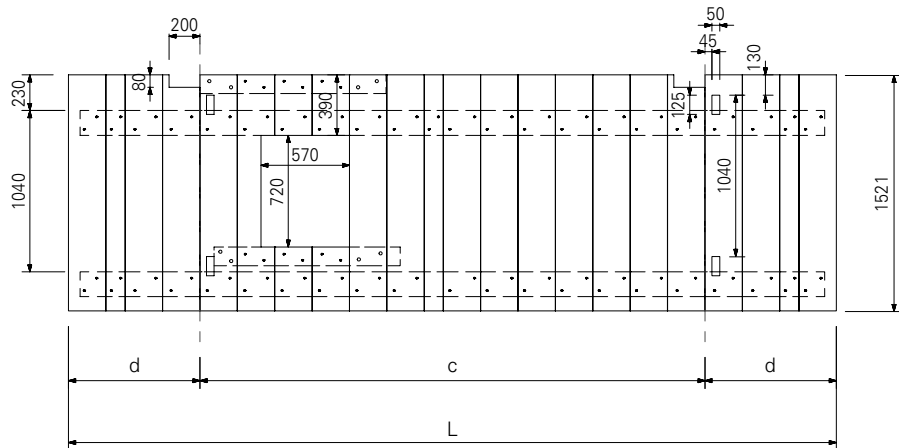

Fig. C1.02b

Layout of finishing platform

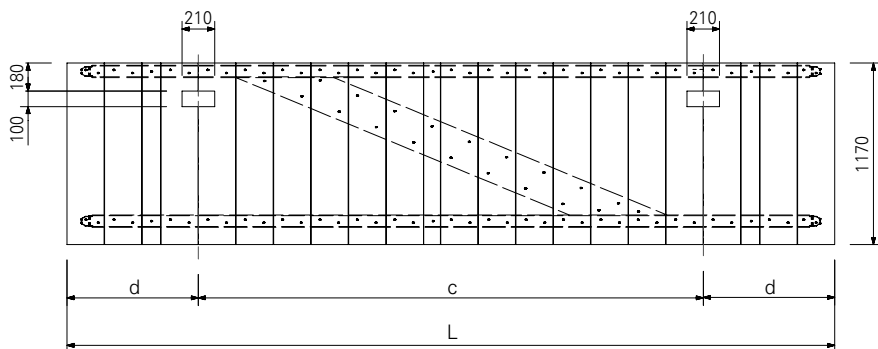

Fig. C1.02c

Dimensions in mm

- L = platform length
- c = bracket spacing
- d = cantilevers

C1 Planning and work preparation for the platforms

Corner platforms are to be erected in such a way that free access is possible around the corners of the building when the formwork is in a shuttered or retracted position.

Measures:

An extended cantilever on working formwork.

Leading edges at the platform ends are to be secured with end guardrails. (Fig. C1.03)

The girder cantilever is to be taken into consideration within the scope of the verification process with the help of the application diagrams.

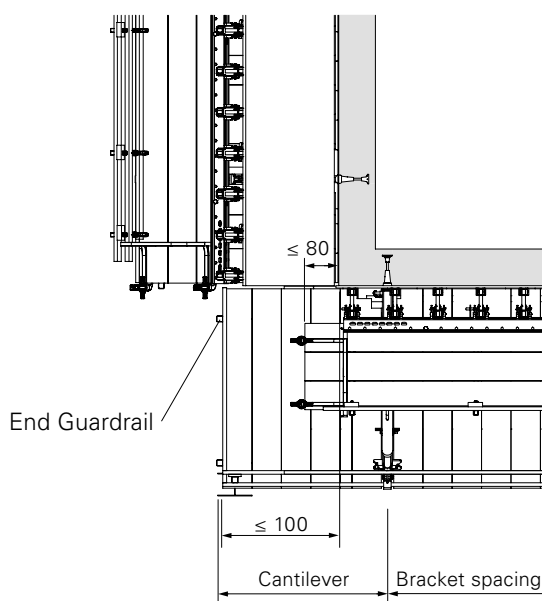
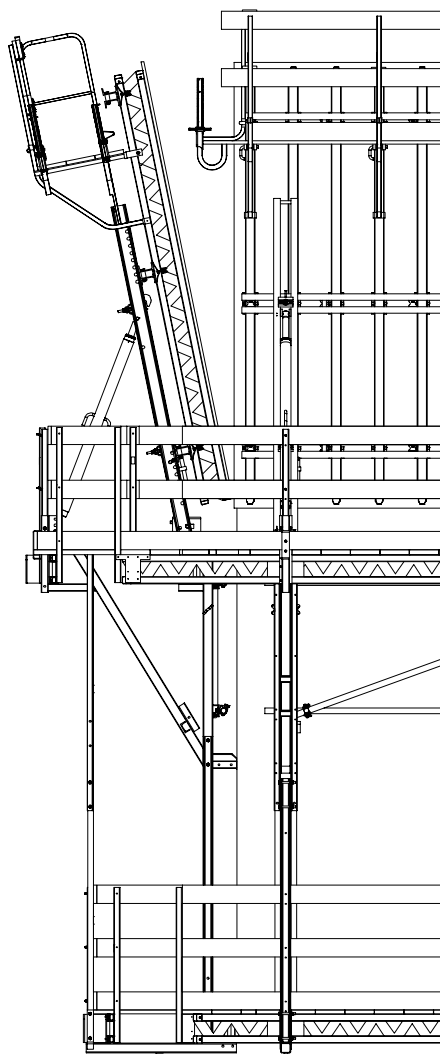

Fig. C1.03

C1 Planning and work preparation for the platforms

Table 1
Minimum dimensions of the planking

	min. thickness [mm]	min. width [mm]	max. span [m]
Working platform	40	240	
Finishing platform	40	240	
Concreting platform GB 80	40	240	2.25
TRG 80	40	240	2.25

Minimum requirements: Soft Wood Strength Class C24 according to DIN 338

Alternatively, laminated veneer timber with building inspection approval can also be used on the working and finishing platforms provided their use as a supporting and bracing component, as well as a substitute for solid wood according to DIN ENV 1995, is allowed. Minimum thickness 35 mm. The boundary conditions of the respective approval must be observed.

Table 2
Permissible girder spans

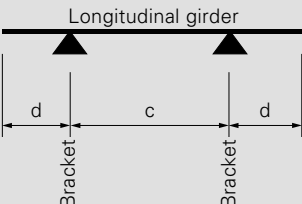
Static system: 	Longitudinal girder Type	max. span $d \leq c/2$ [m]	max. span c [m]
	Lattice Girder GT 24	1.95	5.17
Solid Web Girder VT 20	2.18	4.37	
Timber 8 x 16*	1.70	3.56	
2x Lattice Girder GT 24	2.73	7.22	
2x Solid Web Girder VT 20	3.05	6.10	
Timber 16 x 16*	2.11	4.95	

*Minimum requirement: Soft Wood Strength Class C24 according to DIN 338

C1 Planning and work preparation for the platforms

Guardrails and ladder safety cage

On all platform levels, leading edges are to be protected with guardrails. In order to maintain permissible spans and cantilevers, additional guardrail posts can also be mounted, see Table 3.

Standard assembly.

(Fig. C1.04a)

Working scaffold.

(Fig. C1.04b)



- In accordance with BGI 778, working areas positioned at great heights are to be secured through safety nets.
- Safety nets must be removed in the event of a storm warning.

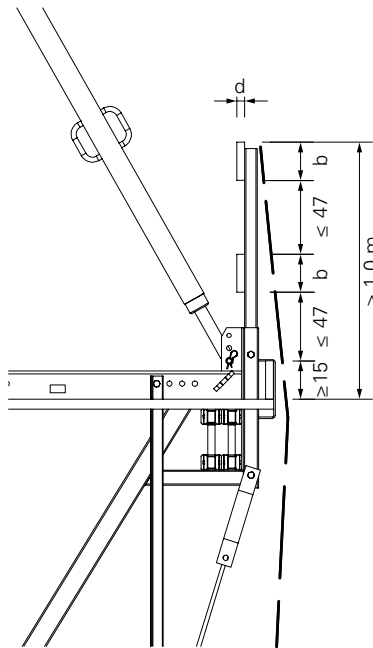

Fig. C1.04a

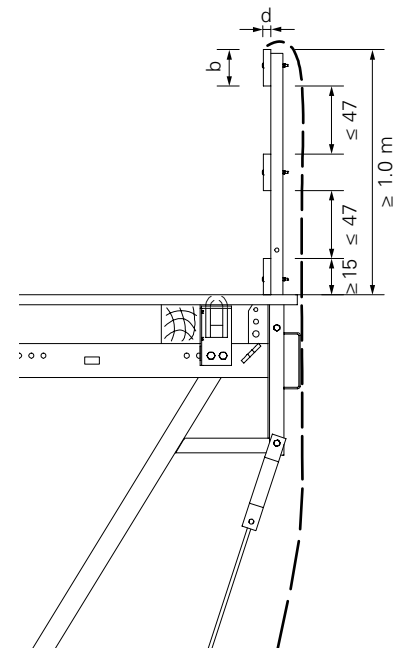

Fig. C1.04b

Table 3
Permissible spans of handrail boards

Dimensions of handrail boards		Case 1: 2x guardrail post + projection		Case 2: 3 or more guardrail posts
d/b [mm]	Net*	perm. A ₁ [m]	perm. C [m]	perm. A ₂ [m]
40/120	without	≤ 3.07	0.91	≤ 3.56
	with	≤ 2.21	0.85	≤ 2.21
30/150	without	≤ 2.16	0.73	≤ 2.66
	with	≤ 1.81	0.73	≤ 1.81

* net with 50 % wind permeability

C1 Planning and work preparation for the platforms

Connecting a VARIO GT 24 Panel

Mounting the leading anchor

During the formwork planning, attention must be paid that there is sufficient spacing between the bracket axis and the adjacent Formwork Girders GT 24. Otherwise mounting the Leading Anchor (34/37) with the Anchor Positioning Stud M24 (42) is not possible. (Fig. C1.05)

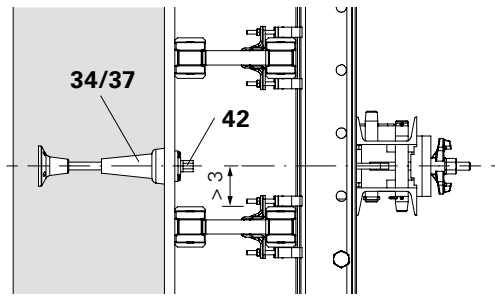

Fig. C1.05

Height Adjusting Units

Depending on the weight of the formwork, the number of Height Adjusting Units CB, SCS (72) is to be determined for each Strongback. (Fig. C1.06)

Perm. $V_1 = 12.8 \text{ kN}$.

Fix all walers (78.1) in the area of the Strongback (70) with Waler Fixations U100 – U120 (71).

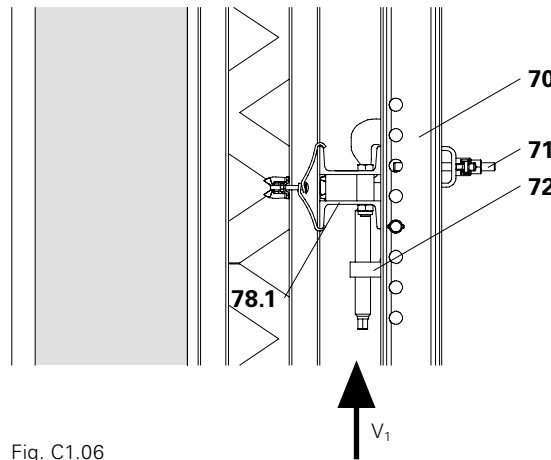

Fig. C1.06

Strongback CB 270 (70.1)

The top Height Adjusting Unit is only mountable with standard waler spacings of 1.78 m or 2.07 m. (Fig. C1.07a)

Strongback CB 380 (70.2)

The top Height Adjusting Units are only mountable on walers in standard spacings from 1.78 m to 3.26 m from the lowest-positioned waler. (Fig. C1.07b)

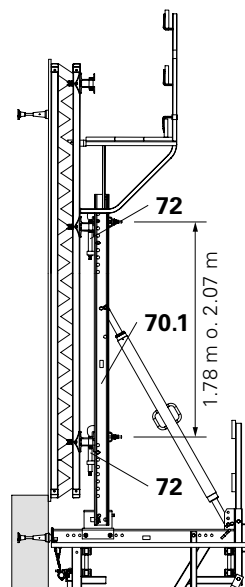

Fig. C1.07a

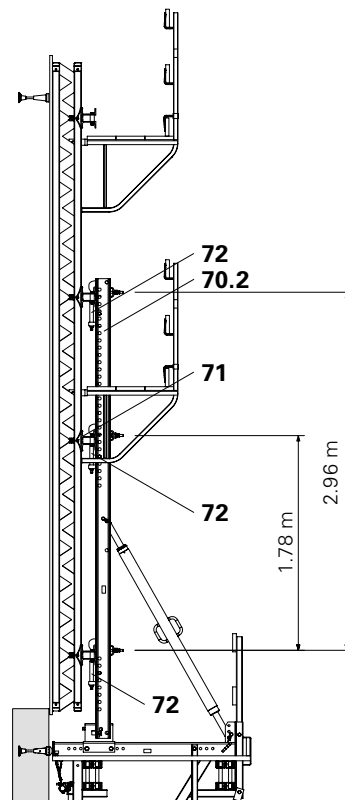

Fig. C1.07b

C1 Planning and work preparation for the platforms

Adjustable Brace CB 164-224

According to the formwork water spacing, fix the Adjustable Brace CB 164-224 (44) in the bottom hole using Bolts $\varnothing 25 \times 180$ (73).

(Fig. C1.08a)

or in the top hole

(Fig. C1.08b)

of the strongback.

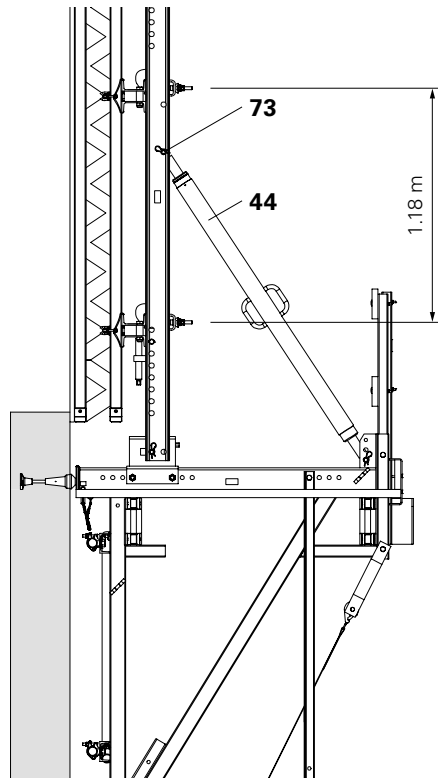

Fig. C1.08a

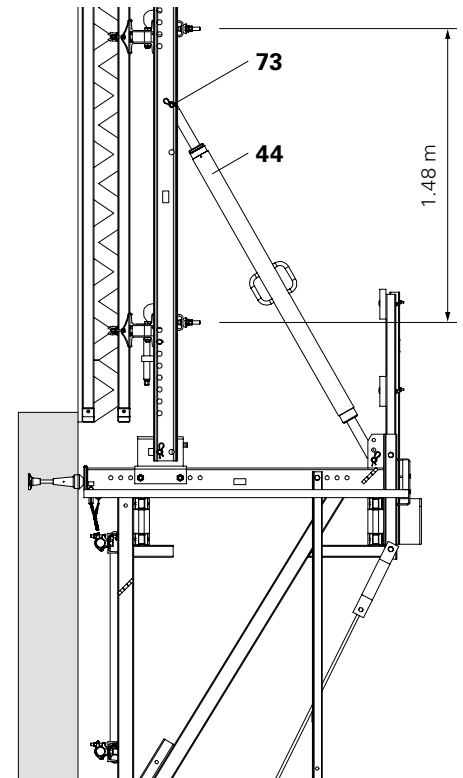

Fig. C1.08b

Anchoring

As a rule, the edge distance of the anchoring (34/37) can be executed with $a = 35$ cm. If necessary, this can deviate from the plan. (Fig. C1.09)

Steel Waler Universal SRU U120

$x = 57.6$ cm

$y = 69.8$ cm

Steel Waler SRZ U100

$x = 58.1$ cm

$y = 69.3$ cm

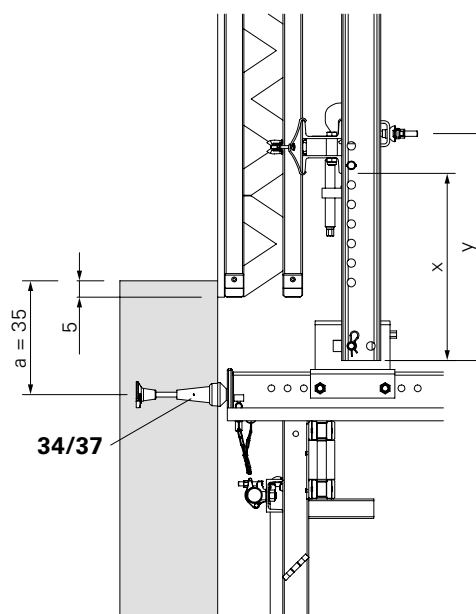
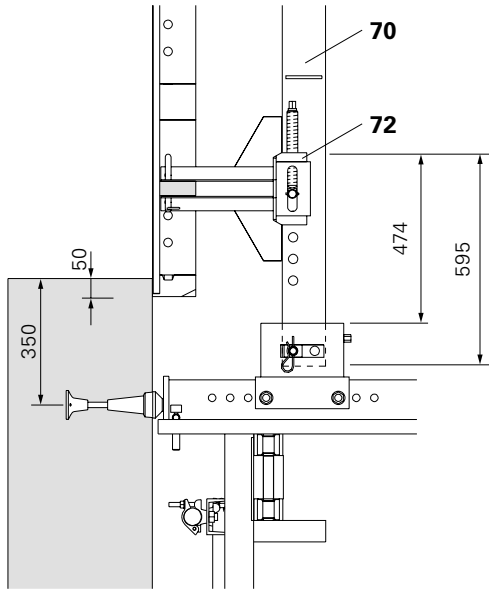

Fig. C1.09

C1 Planning and work preparation for the platforms

Connecting a TRIO/MAXIMO Panel by means of a Connector TRIO-CB

Connection to horizontal struts
Height of girder: 24 cm.



Dimensions in mm

Fig. C1.10a

Connection to vertical struts

Height of girder: 24 cm
With a formlining projection of 5 cm and an adjusting length of approx. 5 cm, the anchoring dimension must be increased to 50 cm.

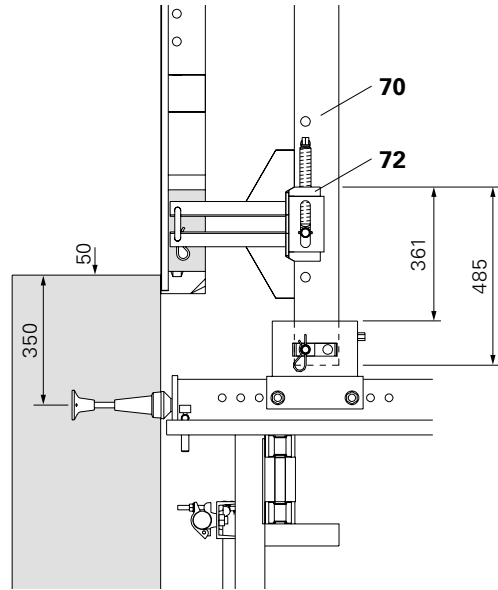

Dimensions in mm

Fig. C1.10b

Position of the Connector TRIO-CB

Layout of C1.10a

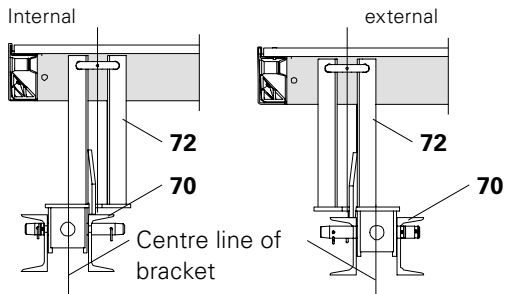

Dimensions in mm

Fig. C1.11a

Layout of C1.10b

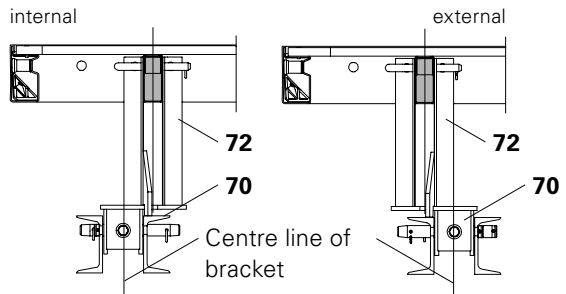

Dimensions in mm

Fig. C1.11b

C1 Planning and work preparation for the platforms

Panel TR 270 x 240 in an upright position

The Connector TRIO-CB is to be bolted to the vertical struts.

(Fig. C1.12a – C1.12c)

The illustrations show girders with a height of 24 cm.

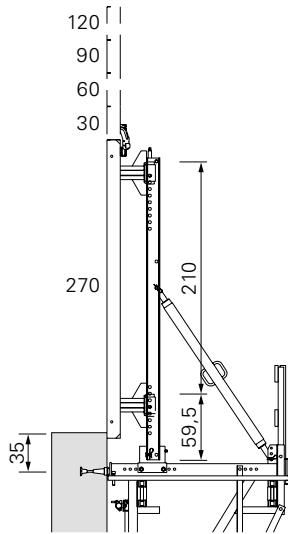

Fig. C1.12a

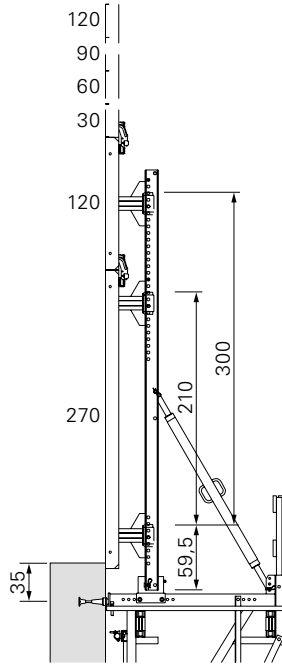

Fig. C1.12b

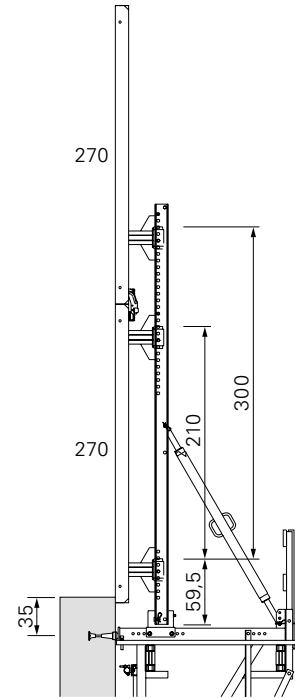

Fig. C1.12c

The Connector TRIO-CB is to be bolted to the vertical struts.

(Fig. C1.13a – C1.13c)

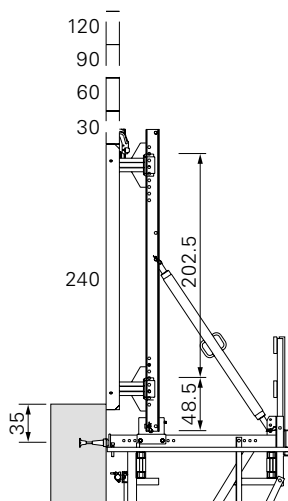

Fig. C1.13a

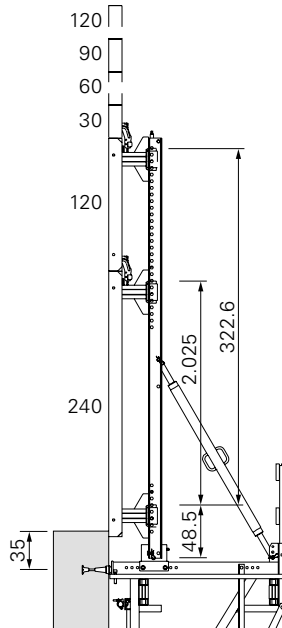

Fig. C1.13b

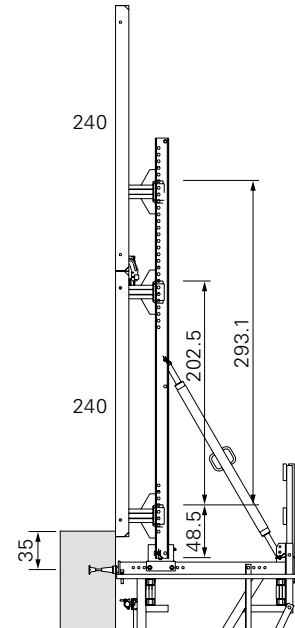

Fig. C1.13c

C1 Planning and work preparation for the platforms

Connecting the TRIO / MAXIMO Panel by means of a Formwork Waler 150 CB

Overview

- 70** Strongback CB 270/380
- 71** Waler Fixation U100 – U120
- 72** Height Adjusting Unit CB, SCS
- 83** Formwork Waler 150 CB
- 84** Clamp Adapter MX / TR – SRU
- 84.1** Bolt ISO 4014 M24 x 80-8.8
- 84.2** Fitting Pin \varnothing 21 x 120
- 84.3** Wingnut Counterplate DW 15
- 84.4** Tie Rod DW 15



Assembly is described in Section B2.

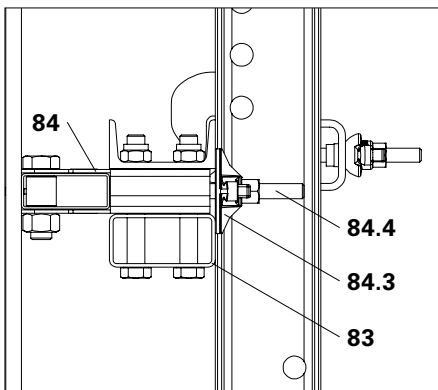

Fig. B2.14b

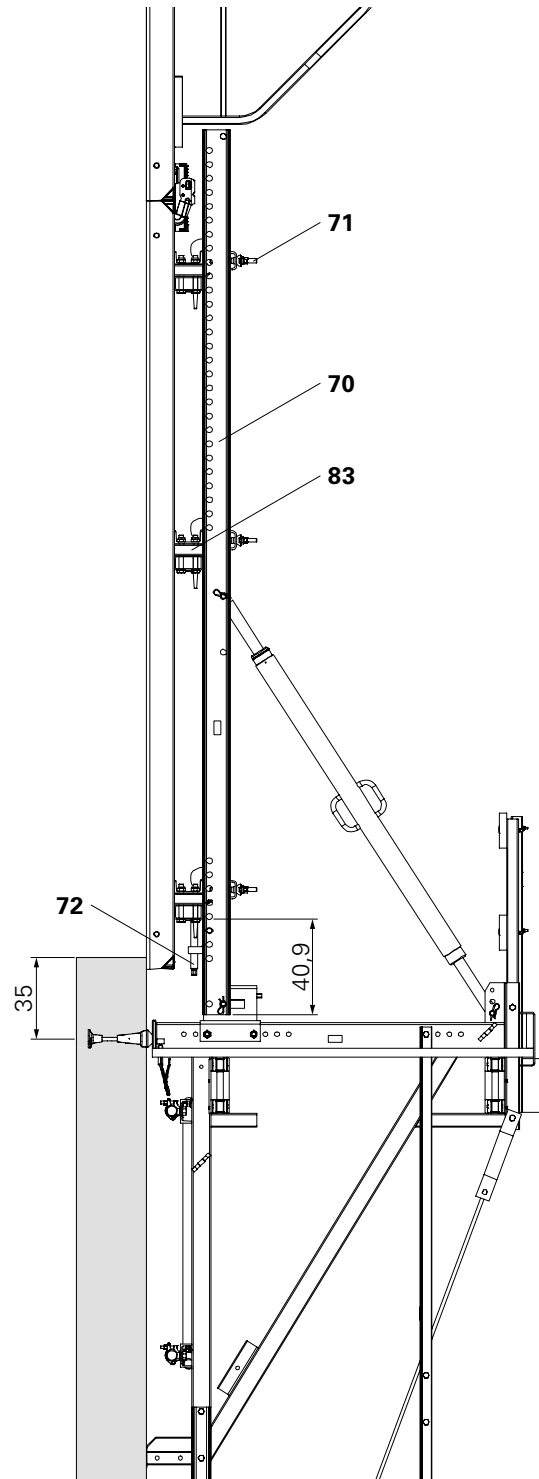

Fig. C1.14

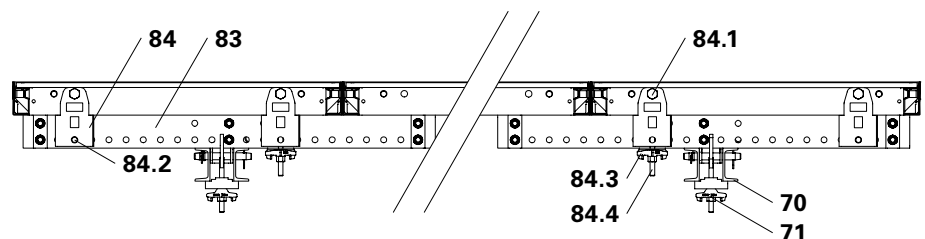

Fig. C1.14a

C1 Planning and work preparation for the platforms

Moving the units

Installation of a compression brace
 In order to prevent the Strongbacks from being pulled out of line during the lifting process due to the redirection of forces, clamp a suitable piece of timber (74) as a compression brace between the top ends of the Strongbacks (70). (Fig. C1.15)

Dimensions of the compression brace, see Table 4.

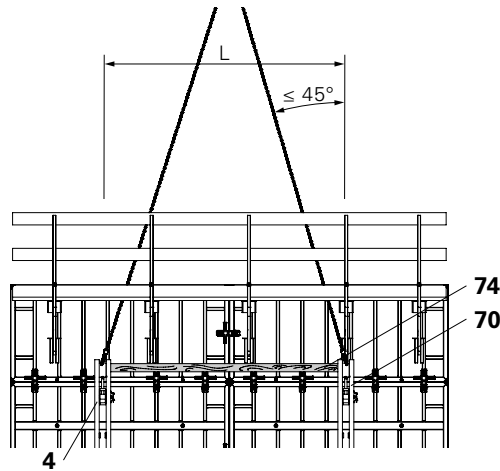

Fig. C1.15

Table 4
Permissible spacing for the Strongbacks CB

Dimensions of the compression brace width x depth [cm]	Permissible spacing for the Strongbacks CB L [m]	
	Crane sling angle $\alpha \leq 30^\circ$	Crane sling angle $\alpha \leq 45^\circ$
10 x 10	4.30	3.80
12 x 12	5.20	5.20
14 x 14	6.00	6.00

The timber ends (74) are to be adapted to suit the U120-Profile of the Strongback CB (70) through chamfering and notching. For fixing by means of Hex. Wood Screws DIN 571 8 x 160 and washers (47), use the drilled holes in the web of the strongback. (Fig. C1.16)

Top view

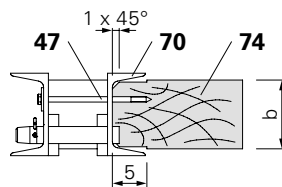
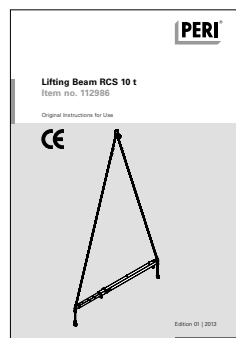

Fig. C1.16



- If no compression braces are used between the Strongbacks or strongly unsymmetrical platforms are to be moved, we recommend the use of the Lifting Beam RCS 10 t, Item no. 112986.
- Follow Instructions for Use at all times.



C1 Planning and work preparation for the platforms

Ladder access

Table 5
Parts list for ladder access

Concreting height [m]		1.5 – 3.0	2.0 – 3.0	3.3 – 4.9	3.8 – 5.4
Working platform – finishing platform spacing [m]		3.65	4.15	5.45	5.95
Item no.	Designation	Parts List			
051430	Sliding Hatch	1	1	1	1
051420	Ladder 220/6	1	1	1	1
051410	Ladder 180/6, galv.	1	1	2	2
051450	Ladder Safety Cage 150, galv.	1	1	1	2
104132	Ladder Safety Cage 75, galv.	–	–	1	–
109105	Ladder Base 30, galv.	1	1	1	1
103718	Ladder Hook, galv.	2	–	2	–
070711	Timber 10 x 10, L = 60 cm for assembly of Ladder Base 30	1*	–**	1*	–**

* The ladders are attached to the top end of the sliding hatch cover.

The bottom ladder is attached using the ladder hook, and with the ladder base on timber at the lower end.

** Screw ladder base tightly on decking of the finishing platform.

C1 Planning and work preparation for the platforms

Weight of the moving unit

Table 6

Assembly Variant	Formwork height up to 3.60 m	Formwork height 3.60 m to 5.40 m
Brackets with bracing and adjusting unit	252 kg	
Suspension of the finishing platforms	196 kg	280 kg
Strongback with compression brace, Adjustable Brace and accessories	Strongback 270	Strongback 380
VARIO	230 kg	295 kg
TRIO/MAXIMO with Connector TRIO-CB	251 kg	337 kg
TRIO/MAXIMO with Formwork Waler 150	368 kg	528 kg
Compression brace between the Strongbacks	70 kg	45 kg
Working and finishing platforms including planking 40 mm, girders and guardrails		
Double GT 24	131 kg/m	
KH 16/16	146 kg/m	
GT 24	108 kg/m	
KH 8/16	115 kg/m	
End Guardrails working platform	34 kg	
End Guardrails finishing platform	24 kg	
Wind bracing		
with Tension Belt	16 kg	
with Tie Rod	30 kg	
Formwork		
VARIO GT 24 Girder Wall Formwork	70 kg/m ²	
TRIO Panel Formwork	60 kg/m ²	
MAXIMO Panel Formwork	70 kg/m ²	
Concreting platform		
VARIO including GB 80	38 kg/m	
TRIO/MAXIMO including TRG 80	40 kg/m	

Example: CB 160

- VARIO GT 24 Girder Wall Formwork Formwork Height $h_s = 4.20$ m
- Platform length $L = 5.00$ m Double GT 24
- Bracing with Tension Belt
- Concreting Platform GB 80

Formwork area = 4.20 m x 5.00 m = 21.0 m²

Weight of the moving unit =

252 kg + 280 kg + 295 kg + 45 kg + 5 m x 131 kg/m + 16 kg + 21 m² x 70 kg/m² + 5 m x 38 kg/m =

3,203 kg

C1 Planning and work preparation for the platforms

Use on circular structures

Parallel arrangement of brackets

Depending on the bracket spacing c , brackets can be positioned parallel to each other starting from a certain radius of the building.

Advantage:

The adjusting unit can be used for tilting the formwork.

The maximum twist in the Scaffold Mounting Ring is $\beta \leq 5^\circ$. The pressure point of the bracket is wedged to compensate for the angle. (Fig. C1.17)

Requirements for the radius of the building: actual $R \geq 5.72 \times c$.

System statics are verified with the application diagrams according to the type test.

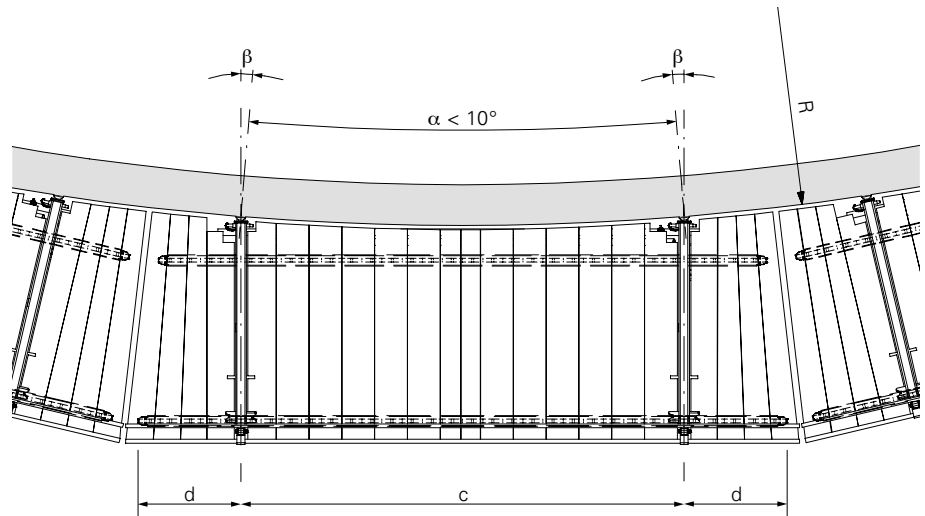

Fig. C1.17

- c actual bracket spacing = anchor spacing
- d middle girder cantilever
- $\alpha = 2 \times$ angle of torsion β
- R radius of the building

Disadvantage of radially-positioned brackets:

The tilting possibilities for the formwork are limited.

Wedges for compensating the angle have to be fitted between the girder and mounting plate. If the arc rise s of the building edge is too big, the innermost girder must be additionally moved outwards by means of packing in order to provide sufficient space between the girder and the building.

(Fig. C1.18)

The same applies to the finishing platforms.

Special measures have to be undertaken if scaffold tube units are installed.

Static proof is to be carried out separately.

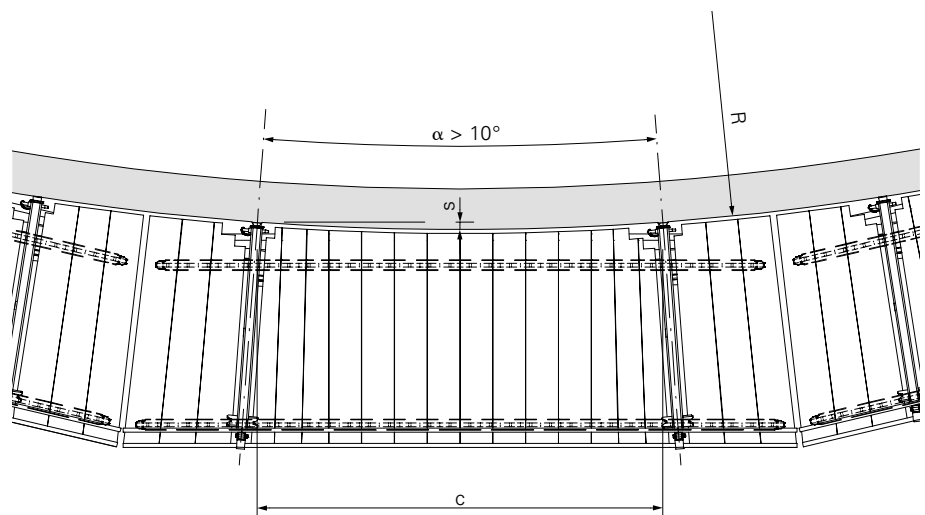

Fig. C1.18

- s Arc rise of the building curvature
- c Anchor spacing

C1 Planning and work preparation for the platforms

Use as working scaffold without formwork

Working scaffold according to DIN EN 12811



Other loads require separate static calculations!

With a load that corresponds to DIN EN 12811 Load Class 3 (200 kg/m^2), the brackets and platforms can be assembled without any additional proof, see C1 Platform decking. (Fig. C1.19a + C1.19b)

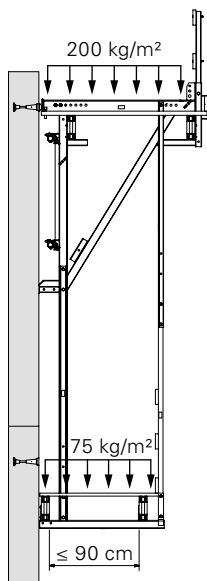

Fig. C1.19a

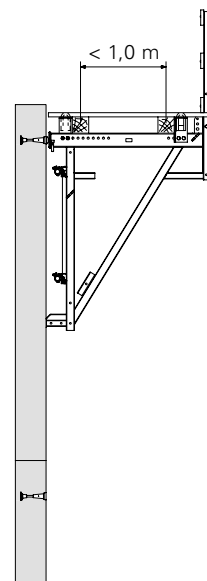

Fig. C1.19b

Working scaffold with finishing platform



If a finishing platform is attached to a working platform with decking on top, ensure that the rear platform connection does not collide with the Handrail Post 200. If necessary, the position of the timber 16/16 and the Platform Connection CB 160 is to be changed. (Fig. C1.20)

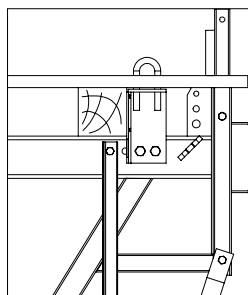

Fig. C1.20

C1 Planning and work preparation for the platforms

Load assumption

Load Combination A – Working

Wind load:

$$q \leq 0.25 \text{ kN/m}^2, v \leq 72 \text{ km/h.}$$

- Working is permitted on all platforms.
- Material storage on the working platform is allowed.

Load Combination B – Storm

Static proof in the form of a type test is given for the following wind loads which indicate the permissible width of influence for the brackets.

$$q = 0.8 \text{ kN/m}^2, v = 129 \text{ km/h}$$

$$q = 1.1 \text{ kN/m}^2, v = 151 \text{ km/h}$$

$$q = 1.3 \text{ kN/m}^2, v = 164 \text{ km/h}$$

- Working not permitted.
- Materials can be left on the working platform.

Formwork height h_s

Concreting height h_B

Length of the wind bracing L_{TB}

Height above the ground z

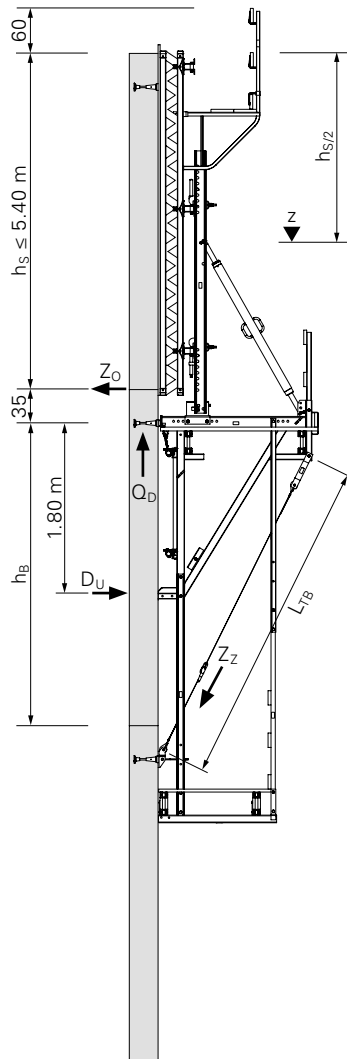

Table 7
Load assumptions

	Dead load [kg/m ²]	Perm. live load* [kg/m ²]	Decisive live loads [kg/m ²] for calculating the bearing forces	
			Working	Storm
Concreting platform	30	150	75	–
Intermediate platform (if required)	30	150	–	–
Working platform	50	200	200	133
Finishing platform	50	75	37.5	–

*Maximum permissible live load for operating condition Working.

- Evenly distribute loads. One-sided loading of cantilevered platform areas is not permitted.
- Working: If several platform levels are loaded, only one can be fully loaded, the other platform levels only 50 %.
- Storm: Reduced load on the working platform for material left behind.

C1 Planning and work preparation for the platforms

Platform dimensioning



Design information CB 160 on request.

Influence factors for dimensioning

- b Width of influence of the bracket
- h_s Formwork height
- h_B Concreting height
- z Operating height above ground
- q Reduced wind flow pressure
- κ service life factor (up to 24 months $\kappa = 0.7$)
- $q(z)$ Wind speed depending on the operating height and the reference dynamic pressure according to the wind zone

Actual width of influence

The actual width of influence is determined with the help of the strongback arrangement and taking into account the formwork cantilever, and compared with the permissible width of influence.

Permissible width of Influence

The permissible width of influence for the formwork height h_s and the actual service duration and height-dependent dynamic wind pressure q is to be taken from the CB 160 design information. The different wind loads in the standard and transition areas as well as in the corners of the buildings are to be taken into account. This results in different permissible widths of influence for these areas.

Special applications

Differing loads, larger formwork heights or inclinations of the building require a separate statical proof for the platforms.

Determining the Wind Loads according to DIN EN 1991-4 and DIN EN 12812

The dynamic wind pressure $q(z)$ is determined from the operating height z , wind load zone WZ and location of use, and reduced by a service life factor κ .

$$q_{\kappa} = \kappa \cdot q(z).$$

According to DIN EN 12812, $\kappa = 0.7$ can be assumed for a service life up to 24 months.

Corner platforms

In the corner area, it is normally necessary to facilitate access around the corner of the structure. For this purpose, corner platforms are formed. A maximum corner overhang of 80 cm is allowed on the concreting platform; for working and finishing platforms, maximum 100 cm is permissible. No overhang is allowed for the formwork nor finishing platform. For larger overhangs, the width of influence of the corner bracket is to be increased accordingly or a separate statistical proof is to be carried out.

Verification of the platforms

Verification of the platform decking and platform beams can take place using the tables, see C1 Platform decking. The length of the cantilevered area of the platform beams must not be larger than half the distance of the two brackets of one unit. In those cases where cantilevers are longer, the main beams together with their fastenings are to be verified by the contractor and additionally secured against lifting.

Verification of the guardrails

Verification of the guardrails for the concreting and intermediate platforms is carried out in accordance with country-specific standards. Verification of the guardrails for the working platform and finishing platform can be done with the help of the tables, see C1 Guardrails and ladder safety cage.

Bearing reactions

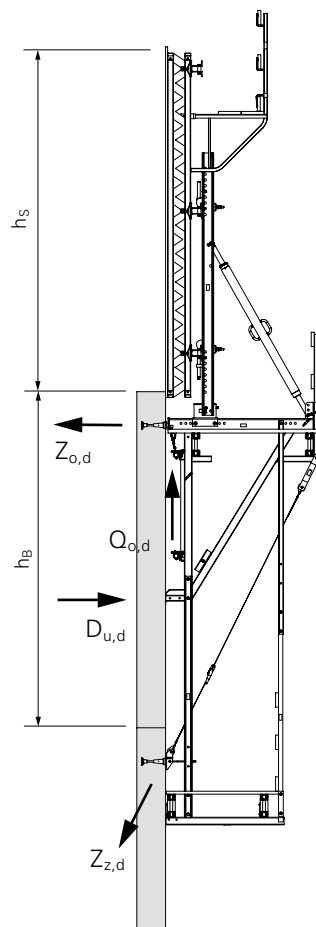

- $Z_{o,d}$ Design tensile force on the bracket anchoring
- $Q_{o,d}$ Vertical design shear force on the bracket anchoring
- $D_{u,d}$ Design compression force to be supported on the base of the bracket
- $Z_{z,d}$ Design tensile force in the wind safety device

The design values of the reaction forces for the permissible width of influence are to be taken from the separate CB 160 design information and are to be linearly interpolated for the formwork height h_s and the assumed dynamic wind pressure q_{κ} . These values must be converted with the help of the given formulae for the actual width of influence. The reaction forces Z_o and Q_o on the climbing anchor are to be verified separately with the help of the interaction charts for each load case.

C1 Planning and work preparation for the platforms

Anchoring verification



Design information CB 160 on request.

The following are to be verified or determined by the structural engineer responsible for the building:

- The safe transfer of the bearing forces into the concrete.
- The safe transfer of all reaction forces as well as the stability of the building under construction.
- The required concrete strength before the platforms can be loaded.
- The arrangement and load-bearing capacity of possible additional reinforcement.

Load transfer

- The bearing forces of the maximum shear force Q_0 are diverted into the concrete via the pressure on the periphery of the climbing cone's cup V_T through the bedding on the cone V_K and into the concrete.
- The maximum tensile force Z_0 is diverted into the concrete via the pressure on the threaded anchor plate Z_A . (Fig. C1.21)



Sufficient load-bearing capacity of the anchoring is carried out by comparing the design values for the anchor tensile force and the anchor shear force with the design resistances whilst taking into account the interaction.

In Germany, Building Authority Approval Nr. Z-21.6-1767 and Z-21.6-1766 are to be taken into consideration for the verification of the load transfer into the concrete.

For determining the required anchoring depth h_{nom} and concrete strength with specified minimum edge distances, take into consideration the design information CB 160.

If the minimum requirements regarding edge distances, reinforcement or concrete strength are not met, additional investigations for these conditions are to be implemented.

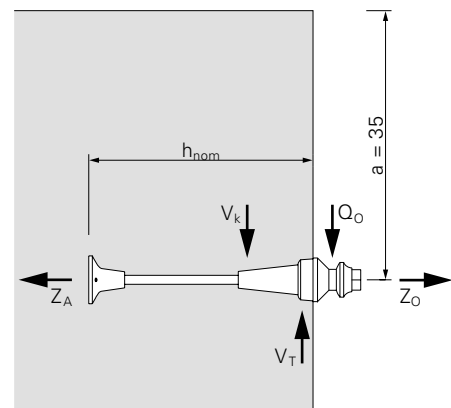

Fig. C1.21

CB 160 Climbing Formwork



Item no.	Weight kg
051100	79.200

Climbing Bracket CB 160

Complete Climbing Scaffold Bracket CB 160.

Complete with

- 2 pc. 017040 Screw-On Coupler AK 48, galv.
- 1 pc. 701209 Guardrail Post CB 160
- 1 pc. 710222 Bolt ISO 4014 M16 x 80-8.8, galv.
- 1 pc. 070890 Nut ISO 7042 M16-8, galv.

Note

Delivery condition: handrail post in transport securing device.

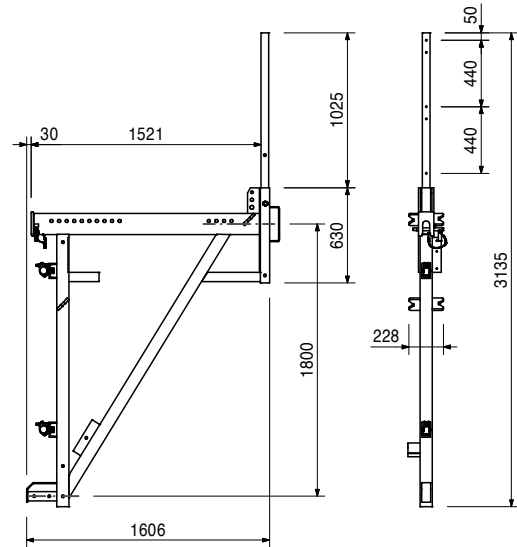
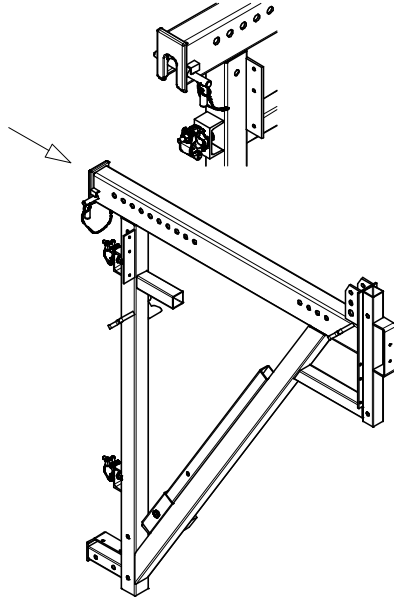

051130	12.900
--------	--------

Adjusting Unit CB 160

For Climbing Bracket CB 160.

Complete with

- 2 pc. 711084 Bolt ISO 4014 M20 x 150-8.8, galv.
- 2 pc. 781053 Nut ISO 7042 M20-8, galv.

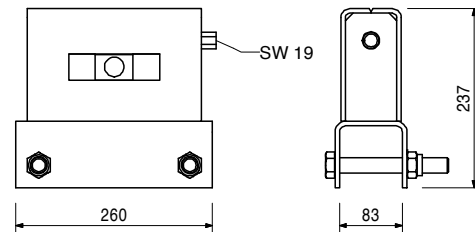
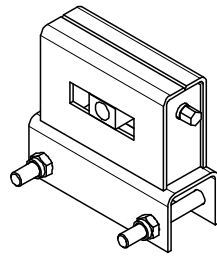

CB 160 Climbing Formwork



Item no.	Weight kg
051120	4.590

Platform Connection CB 160

For moving platform units and for mounting platform decking on the Climbing Bracket CB 160 when used as working scaffold.

Complete with

2 pc. 711078 Bolt ISO 4014 M20 x 130-8.8, galv.
2 pc. 781053 Nut ISO 7042 M20-8, galv.

Note

Follow Instructions for Use!

Technical Data

Permissible load-bearing capacity 500 kg.

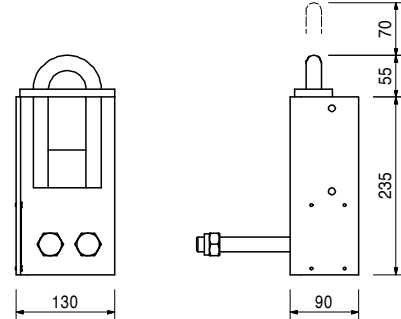
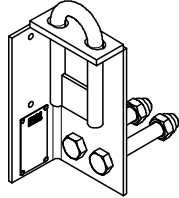

051060	73.400
051150	103.000

Strongbacks CB

Strongback CB 270

Strongback CB 380

For assembling system formwork on Climbing Brackets CB 240 and 160. For formwork heights up to 5.40 m.

Complete with

1 pc. 715936 Pin with Clamping Sleeve
1 pc. 018060 Cotter Pin 4/1, galv.

Technical Data

Permissible load-bearing point capacity 1.9 t.

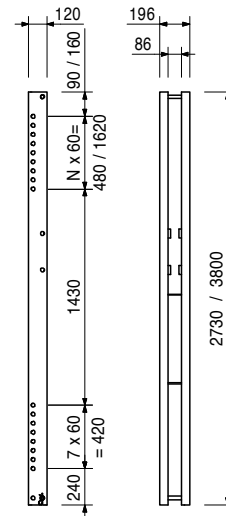
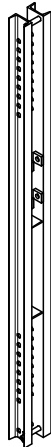

CB 160 Climbing Formwork



Item no.	Weight kg
051110	25.300

Adjustable Brace CB 164-224
For aligning the Strongback CB.

Complete with
2 pc. 715936 Pin with Clamping Sleeve
2 pc. 018060 Cotter Pin 4/1, galv.

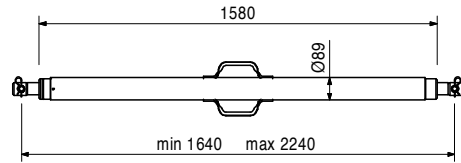
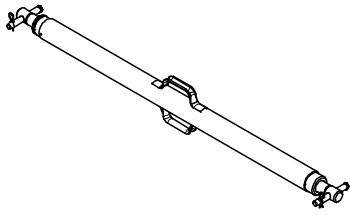

051090	13.500
--------	--------

Connector TRIO-CB
For fixing TRIO panels to the Strongback CB. Used on horizontal or vertical struts. With integrated height adjustment.

Complete with
1 pc. 715936 Pin with Clamping Sleeve
1 pc. 018060 Cotter Pin 4/1, galv.

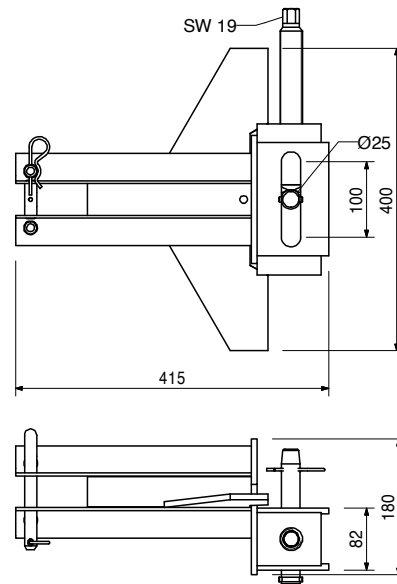
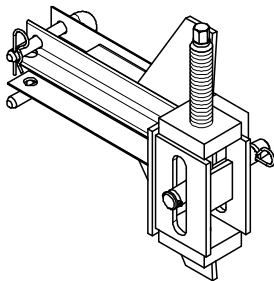

110059	2.840
--------	-------

Waler Fixation U100 – U120
For fixing VARIO GT 24 panels to Strongbacks CB, SCS and Steel Waler SRU.

Complete with
1 pc. 110055 Cross Clamp, galv.
1 pc. 118260 Spherical Nut RD 16, galv.

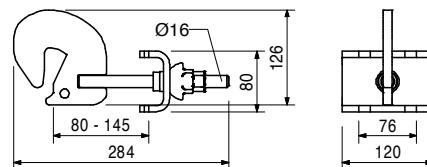
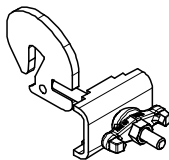

CB 160 Climbing Formwork

Item no.	Weight kg
129689	6,960

Height Adjusting Unit-2 CB/SCS/RCS

For height adjustment of RUNDFLEX panels on the Strongbacks CB/RCS/SCS.

Complete with

1 pc. 715936 Pin with Clamping Sleeve
1 pc. 018060 Cotter Pin 4/1, galv.

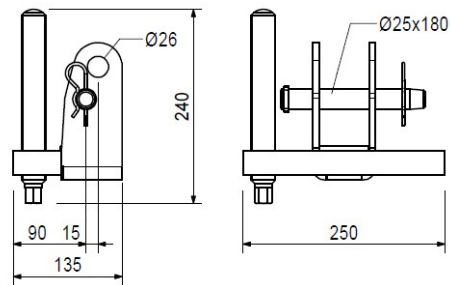
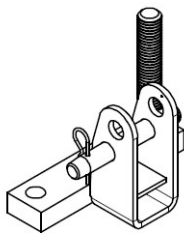

129720	8.040
--------	-------

Waler Fixation-2 U100 – U120

For fixing VARIO GT 24 panels to strongbacks CB, SCS, Steel Waler SRU if anchoring is done through the strongback.

Complete with

2 pc. 118260 Spherical Nut RD 16, galv.

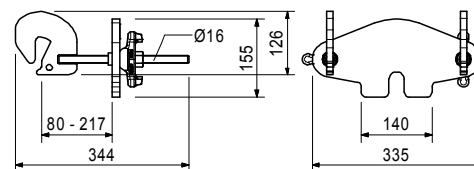
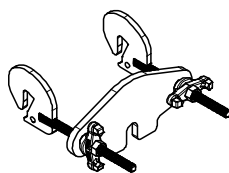

127633	38.700
--------	--------

Formwork Waler 150 CB

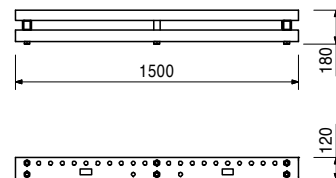
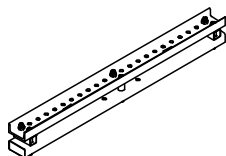

127659	3.980
--------	-------

Clamp Adapter MX/TR-SRU

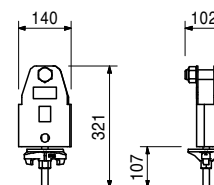
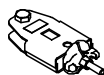

CB 160 Climbing Formwork



Item no.	Weight kg
051230	17.000

Finishing Platform Beam CB
For assembling finishing platforms.

Complete with
4 pc. 710232 Bolt ISO 4014 M16 x 130-8.8, galv.
4 pc. 070890 Nut ISO 7042 M16-8, galv.

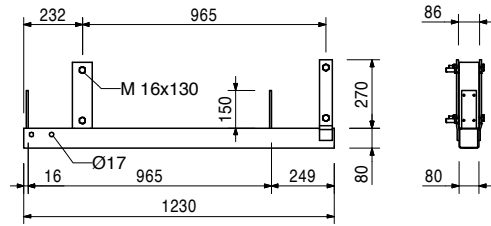
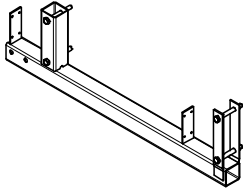

051200	44.400
--------	--------

Platform Post CB 225
For assembling finishing platforms. For concreting heights up to 3.60 m. In combination with Post Extension CB 180 for concreting heights from 3.60 to 5.40 m.

Complete with
2 pc. 710232 Bolt ISO 4014 M16 x 130-8.8, galv.
2 pc. 070890 Nut ISO 7042 M16-8, galv.

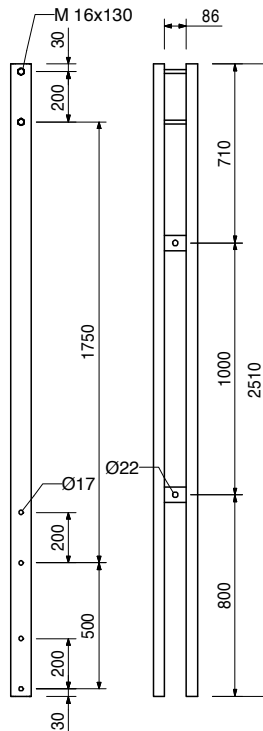

CB 160 Climbing Formwork

Item no.	Weight kg
051050	26.400

Post Extension CB 180

For assembling finishing platforms. In combination with Platform Post CB 225 for concreting heights from 3.60 to 5.40 m.

Complete with

2 pc. 710232 Bolt ISO 4014 M16 x 130-8.8, galv.
2 pc. 070890 Nut ISO 7042 M16-8, galv.

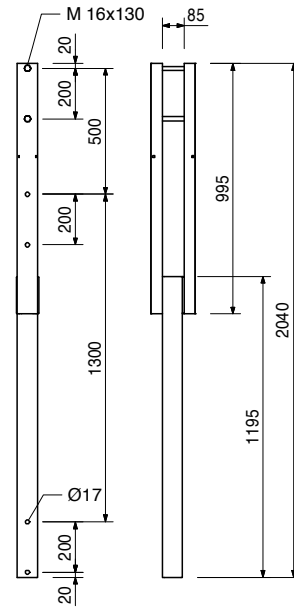

051190	17.400
--------	--------

Handrail Post CB 200

For assembling guardrails on finishing platforms. Basic extension for Handrail Post CB 190 and 370.

Complete with

1 pc. 710232 Bolt ISO 4014 M16 x 130-8.8, galv.
1 pc. 070890 Nut ISO 7042 M16-8, galv.

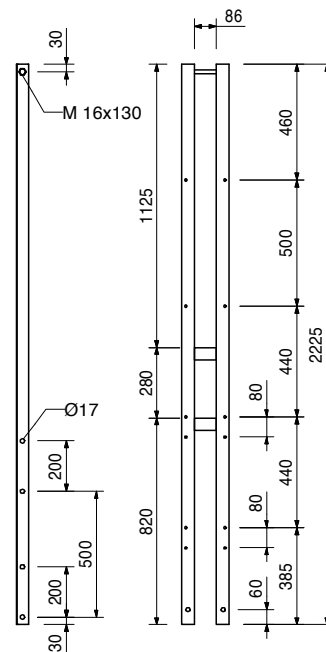
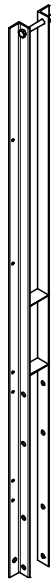

CB 160 Climbing Formwork



Item no.	Weight kg
051210	19.000
051220	34.600

Handrail Posts CB
Handrail Post CB 190
Handrail Post CB 370

For assembling guardrails on finishing platforms.
 Handrail Post CB 190 for concreting heights up to 3.60 m. Handrail Post CB 370 for concreting heights from 3.60 to 5.40 m.

Complete with

2 pc. 710232 Bolt ISO 4014 M16 x 130-8.8, galv.
 2 pc. 070890 Nut ISO 7042 M16-8, galv.

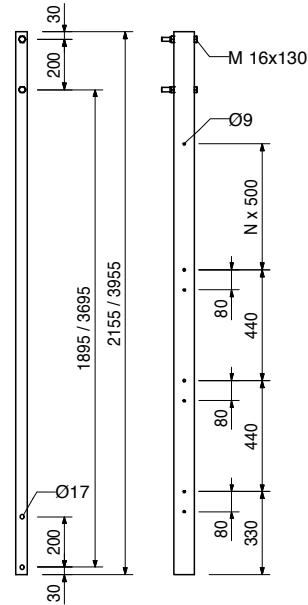

			L
026415	3.550	Scaffold Tubes Steel Ø 48.3 x 3.2	
026417	0.000	Scaff. Tube Steel Ø 48.3 x 3.2, special length	
026411	3.550	Cutting Cost Scaffold Tube	
026412	7.100	Scaff. Tube Steel Ø 48.3 x 3.2, l = 1.0 m	1000
125976	8.900	Scaff. Tube Steel Ø 48.3 x 3.2, l = 2.0 m	2000
026413	10.650	Scaff. Tube Steel Ø 48.3 x 3.2, l = 2.5 m	2500
114287	12.500	Scaff. Tube Steel Ø 48.3 x 3.2, l = 3.0 m	3000
026414	14.200	Scaff. Tube Steel Ø 48.3 x 3.2, l = 3.5 m	3500
026419	17.750	Scaff. Tube Steel Ø 48.3 x 3.2, l = 4.0 m	4000
026418	21.600	Scaff. Tube Steel Ø 48.3 x 3.2, l = 5.0 m	5000
		Scaff. Tube Steel Ø 48.3 x 3.2, l = 6.0 m	6000

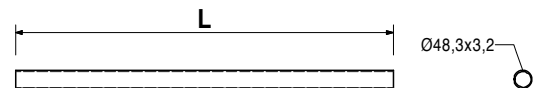
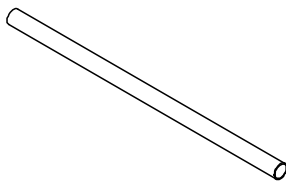

017010	1.400	Swivel Coupling DK 48/48, galv. For Scaffold Tubes Ø 48 mm.
--------	-------	---

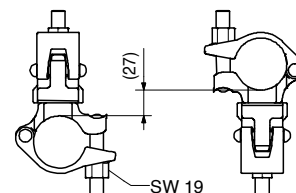
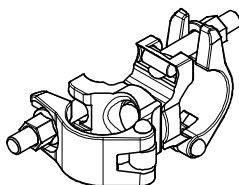

CB 160 Climbing Formwork

Item no.	Weight kg
017020	1.120

Standard Coupler NK 48/48, galv.
For Scaffold Tubes \varnothing 48 mm.

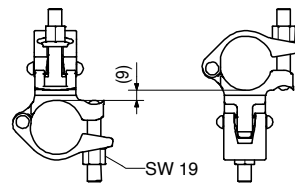
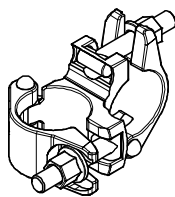

017040	0.850
--------	-------

Screw-On Coupler AK 48, galv.
For Scaffold Tubes \varnothing 48 mm.

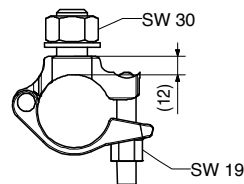
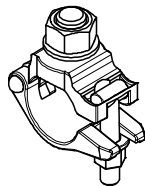

051160	1.050
--------	-------

Guardrail Connector CB
For assembling scaffold tubes on handrail posts.

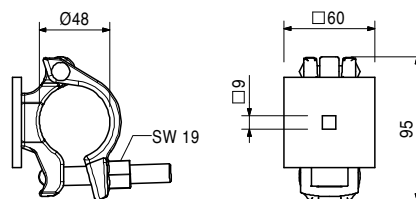
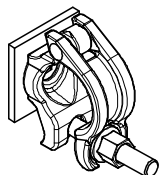

Accessories

126228	0.030
--------	-------

F.H. Bolt DIN 603 M8 x 70 MU, galv.

051610	6.940
--------	-------

Side Guardrail Post CB
For assembly of an end guardrail. Bolted to the platform main beam.

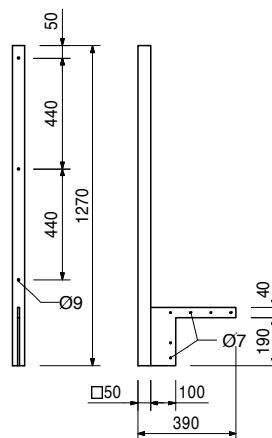
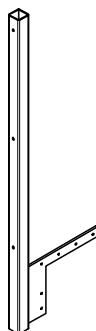

Accessories

051640	0.014
--------	-------

Lag Screw DIN 571 6 x 80, galv.

CB 160 Climbing Formwork



Item no.	Weight kg
051630	11.000

Intermediate Handrail Post CB

For assembling a guardrail with large cantilevers.
Bolted on the platform main beam.

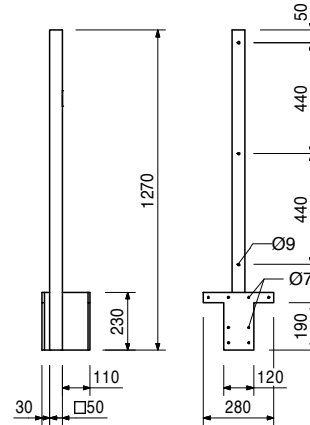
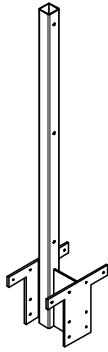

Accessories

051640	0.014
051610	6.940

Lag Screw DIN 571 6 x 80, galv.
Side Guardrail Post CB

065066	15.100
--------	--------

End Guardrail Frame 55

Clampable end guardrail for all PERI scaffold platforms and climbing systems.

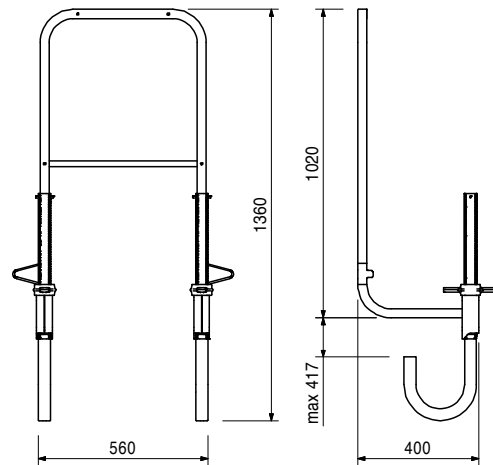
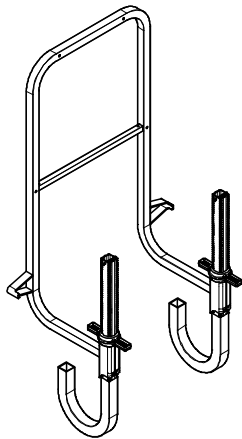

051640	0.014
024260	0.027
024520	0.052

Lag Screws DIN 571, galv.
Lag Screw DIN 571 6 x 80, galv.
Lag Screw DIN 571 8 x 80, galv.
Lag Screw DIN 571 8 x 160, galv.

L
80
80
160

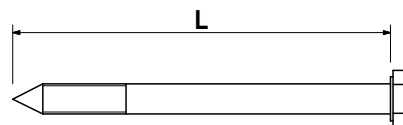
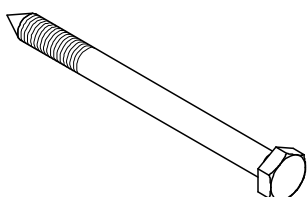

CB 160 Climbing Formwork

Item no. Weight kg

Item no.	Weight kg		L
024540	0.005	TSS-Torx TSS-Torx 6 x 40, galv.	40
024690	0.008	TSS-Torx 6 x 80, galv. For Torx Bits TX 30. Self-drilling.	80

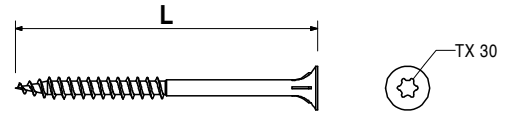
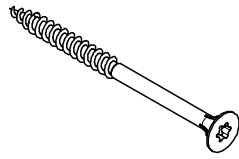

051650	0.060	F.H. Bolt DIN 603 M6 x 180 MU, galv. With nut.	
--------	-------	--	--

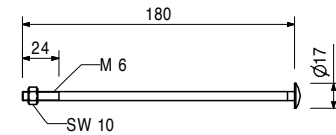
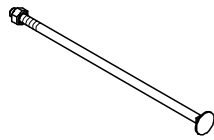

Item no.	Weight kg		L	B
710240	0.050	F. H. Bolts DIN 603 M8, galv.	100	80
024360	0.058	F.H. Bolt DIN 603 M8 x 125 MU, galv.	125	113
108834	0.085	F.H. Bolt DIN 603 M8 x 180 MU, galv. With nut.	180	28

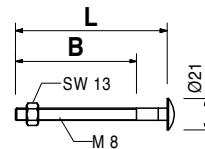

029470	0.723	Scaffold Mounting Ring M24, galv. Anchor System M24. For anchoring climbing systems.	
--------	-------	---	--

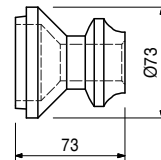
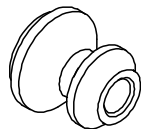

029560	0.535	Accessories Bolt ISO 4014 M24 x 120-10.9, galv.	
--------	-------	---	--

CB 160 Climbing Formwork



Item no.	Weight kg
029560	0.535

Bolt ISO 4014 M24 x 120-10.9, galv.
High-strength bolts for anchoring climbing systems.

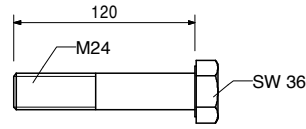
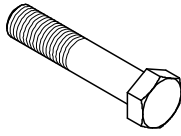

114158	1.030
--------	-------

Screw-On Cone-2 M24/DW 20, galv.
Anchor system M24.
For anchoring climbing systems.

Note
Separate design information on request.

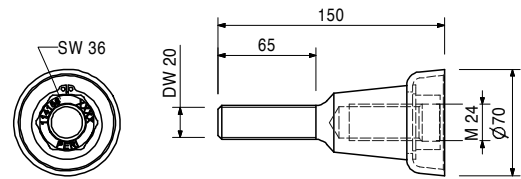
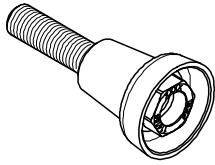

Accessories

030860	0.792	Threaded Anchor Plate DW 20
--------	-------	------------------------------------

030860	0.792	Threaded Anchor Plate DW 20 For use with Tie Rod DW 20, B 20 or Screw-On Cone-2 M24/DW 20. For anchoring in concrete.
--------	-------	---

Note
Lost anchor part.

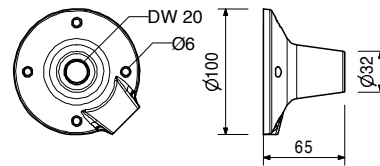
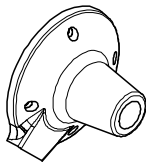

031220	1.010	Climbing Cone-2 M24/DW 15, galv. Anchor system M24. For anchoring climbing systems.
--------	-------	--

Note
Separate design information on request.

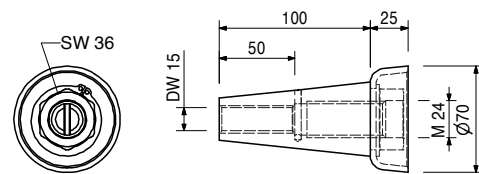
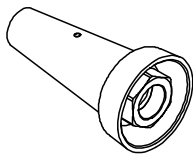

Accessories

030840	0.515	Threaded Anchor Plate DW 15
030030	1.440	Tie Rod DW 15, spec. length
030740	1.550	Tie Rod B 15, spec. length

030840	0.515	Threaded Anchor Plate DW 15 For use with Tie Rod DW 15 or B 15. For anchoring in concrete.
--------	-------	--

Note
Lost anchor part.

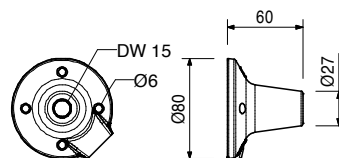
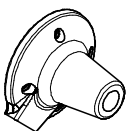

CB 160 Climbing Formwork

Item no. Weight kg

		Tie Rod DW 15
030030	1.440	Tie Rod DW 15, spec. length
030050	0.000	Cutting Cost Tie Rod DW 15, B 15

Note

Non-weldable! Take official approval into consideration!

Technical Data

Permissible tension force 90 kN.

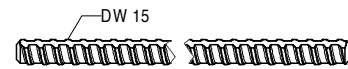
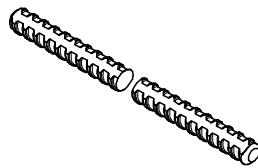

		Tie Rod B 15
030740	1.550	Tie Rod B 15, spec. length
030050	0.000	Cutting Cost Tie Rod DW 15, B 15

Note

Weldable! Take official approval into consideration!

Technical Data

Permissible tension force 82 kN.

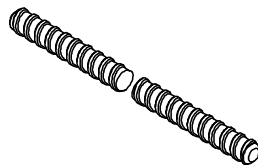

		Spacer Tubes rough DR 22	L
065027	0.359	Spacer Tube rough DR 22, l = 2.00 m	2000
065031	0.050	Spacer Tube rough DR 22, l = 0.27 m	270
065030	0.039	Spacer Tube rough DR 22, l = 0.21 m	210

Plastic Spacer Tube for DW 15, B 15.

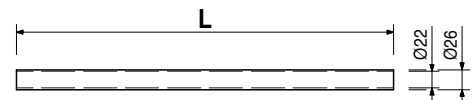
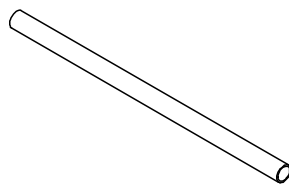

031652	0.247	KK Concrete Cone M24-67/52
		For closing anchor points with Climbing Cone-2, M24/DW 15 and Screw-On Cone-2 M24/DW 20.

Note

Delivery unit 50 pieces.

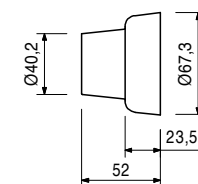
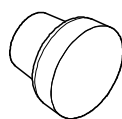

		Accessories
113127	5.400	Glue for Concrete Cones-3, 5,4-kg-Set

Item no.	Weight kg
113127	5.400

Glue for Concrete Cones-3, 5,4-kg-Set
For bonding PERI concrete cones.

Note
See Safety Data sheet!
Consisting of:
6 x Component A, 6 x Component B
2 x Stirring Container, 3 x Stirring Staff

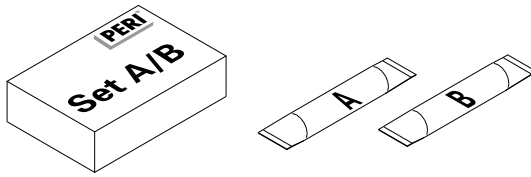

029270	0.331
--------	-------

Advancing Bolt M24, galv.
For fixing the M24 anchor system if the plywood formlining is drilled through.

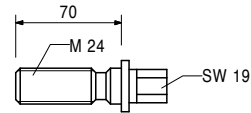
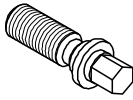

029280	0.196
--------	-------

Accessories
Anchor Positioning Plate M24, galv.

029280	0.196
--------	-------

Anchor Positioning Plate M24, galv.
For fixing the M24 anchor system if the plywood formlining is drilled through.

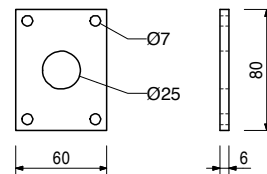
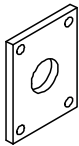

029440	0.005
--------	-------

Accessories
Lag Screw DIN 571 6 x 20, galv.

029440	0.005
--------	-------

Lag Screw DIN 571 6 x 20, galv.

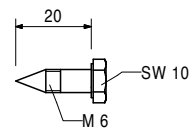

Item no.	Weight kg
026420	0.123

Anchor Positioning Stud M24, galv.

For fixing the M24 anchor system if the plywood formlining is not drilled through.

Note

Allen Key SW 14.

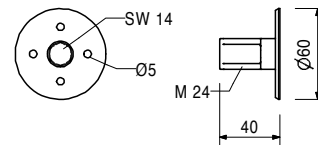

Accessories

027212	0.445
710312	0.005

Allen Key SW 14, long
Nail 3 x 80

107007	3.410
--------	-------

Tension Anchor Connector CB

To prevent tipping over due to wind loads with Tie Rod DW 15.

Complete with

1 pc. 710219 Bolt ISO 4014 M16 x 100-8.8, galv.
1 pc. 070890 Nut ISO 7042 M16-8, galv.

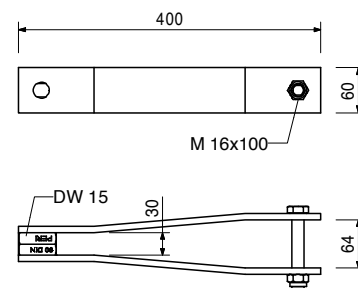
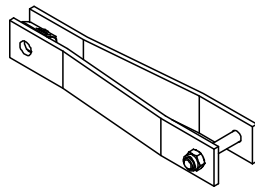

Accessories

116807	1.820
030030	1.440
107008	4.100
116752	5.050

Turnbuckle CB M20/DW 15
Tie Rod DW 15, spec. length
Wall Tension Anchor
Wall Bracing Shoe CB M24

116807	1.820
--------	-------

Turnbuckle CB M20/DW 15

For tensioning of Tie Rod DW 15 to prevent tipping over due to wind loads. Connects Tie Rod DW 15 with Wall Bracing Shoe CB M24.

Complete with

1 pc. 711059 Turnbuckle for tension anchor CB
1 pc. 711060 Eye Bolt M20, left, galv.

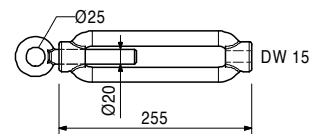
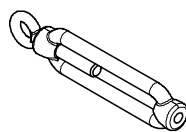

107008	4.100
--------	-------

Wall Tension Anchor

Alternative wall connector to prevent tipping over due to wind loads with Tie Rod DW 15. Including Turnbuckle CB M20/DW 15.

Complete with

1 pc. 027170 Pin Ø 16 x 42, galv.
1 pc. 018060 Cotter Pin 4/1, galv.

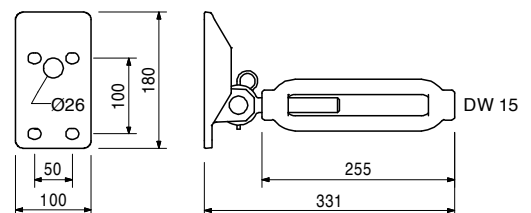
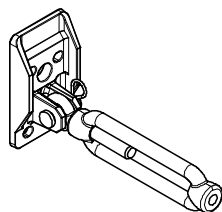

Accessories

026430	0.334
--------	-------

Bolt ISO 4014 M24 x 70-10.9, glav.

Item no.	Weight kg
051260	3.300

Tension Belt Connector CB

To prevent tipping over due to wind loads with tension belt.

Complete with

1 pc. 710219 Bolt ISO 4014 M16 x 100-8.8, galv.
1 pc. 070890 Nut ISO 7042 M16-8, galv.

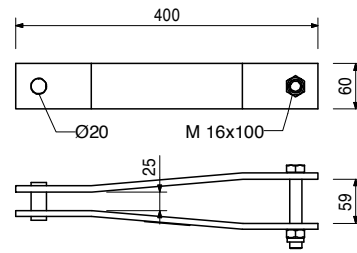
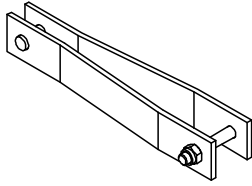

051250	2.790
051270	1.620
116752	5.050

Accessories

Tension Belt, l = 5.70 m, 2.5 t

Tension Belt Connector Wall M24

Wall Bracing Shoe CB M24

051250	2.790
--------	-------

Tension Belt, l = 5.70 m, 2.5 t

To prevent climbing systems from tipping over due to wind loads.

Note

Follow Instructions for Assembly and Use!

Technical Data

Permissible tension force 2.5 t.

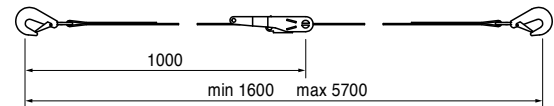
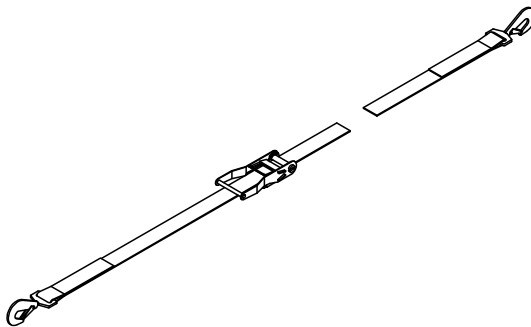

051270	1.620
--------	-------

Tension Belt Connector Wall M24

Wall connector to prevent tipping over due to wind loads with Tension Belt. To be used for climbing systems CB and FB.

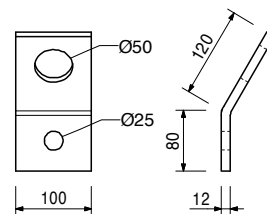
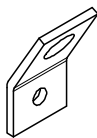

026430	0.334
--------	-------

Accessories

Bolt ISO 4014 M24 x 70-10.9, glav.

CB 160 Climbing Formwork



Item no.	Weight kg
116752	5.050

Wall Bracing Shoe CB M24

To prevent tipping over due to wind loads with Tension Belt or Tie Rod DW 15 and to stabilise the finishing platform. To be mounted on the Climbing Anchor M24 embedded in the concrete.

Complete with

2 pc. 104031 Fitting Pin \varnothing 21 x 120
2 pc. 018060 Cotter Pin 4/1, galv.

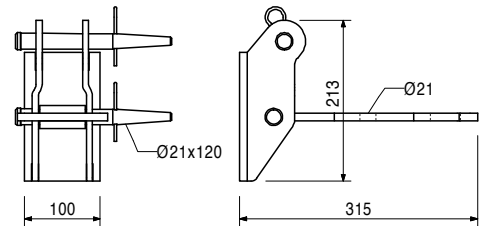
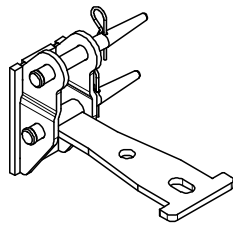

026430	0.334
--------	-------

Accessories

Bolt ISO 4014 M24 x 70-10.9, glav.

026430	0.334
--------	-------

Bolt ISO 4014 M24 x 70-10.9, glav.

High-strength bolt for anchoring climbing systems.

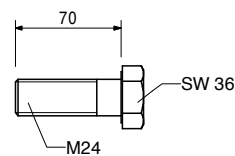
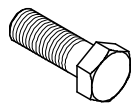

027180	1.760
--------	-------

Ratchet Lever SW 19

For operation of the adjusting unit and of the carriage with drive shaft SW 19.

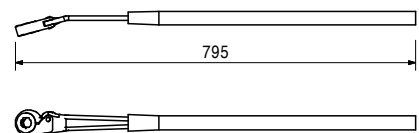
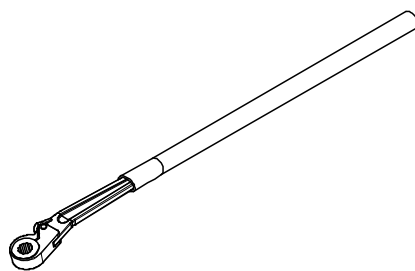

027200	0.100
--------	-------

Accessories

Insert Socket SW 19

031480	2.460
--------	-------

Socket Wrench SW 36, chrome-plated

For various purposes.

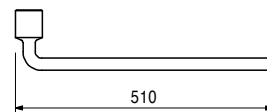
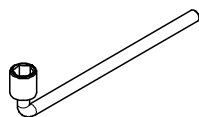

Item no.	Weight kg
027212	0.445

Allen Key SW 14, long

Fits to PERI Anchor Positioning Studs and Allen Key Bolts M16.

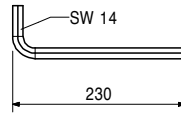
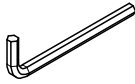

072180	0.560
--------	-------

Ratchet Wrench 1/2"

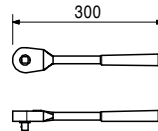
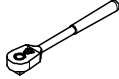

029620	0.075
--------	-------

Socket SW 19-1/2"

Fits to Hex. Bolts M12 or Height Adjusting Unit SW 19.



118638	8.790
--------	-------

Arch. Anchor Sleeve M24-150/2

Centre piece of the double-sided architectural concrete anchoring CB. Anchor Tie DW 15 is passing through. Plate size 150 mm.

Note

Specify wall thickness D.
Separate design information on request.

Technical Data

Min. D = 200 mm.
Max. D = 400 mm.
L = D - 130 mm.

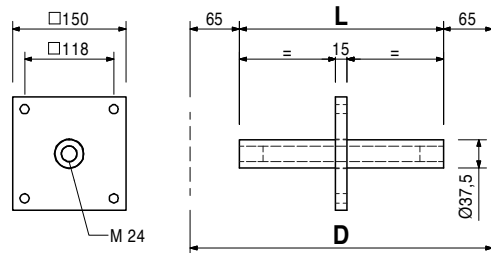
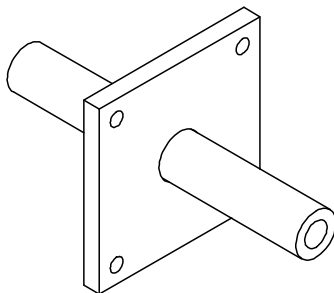

CB 160 Climbing Formwork



Item no. Weight kg

126793	3.190	Arch. Anchor Sleeve M24-150/2
126795	3.490	Arch. Anchor Sleeve M24-150/2, D = 25 Arch. Anchor Sleeve M24-150/2, D = 30

Note
Seperate design information on request.

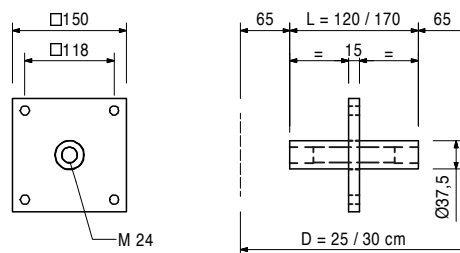
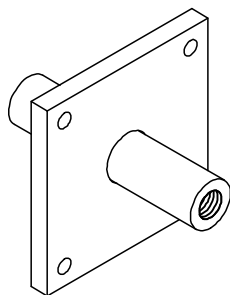

116279 7.530

Arch. Anchor Sleeve M24-120/2
Centre piece of the double-sided architectural concrete anchoring CB. Anchor Tie DW 15 is passing through.
Plate size 120 mm.

Note
Specify wall thickness D.
Seperate design information on request.

Technical Data
Min. D = 200 mm.
Max. D = 400 mm.
L = D - 130 mm.

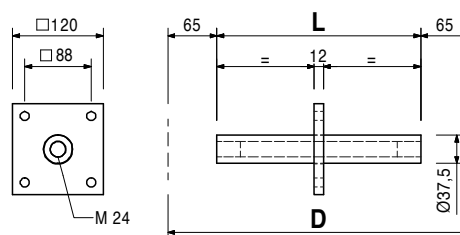
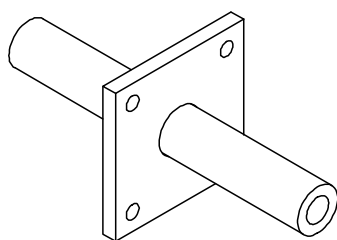

116385 0.189

Arch. Leading Cone M24/DW 26
Leading cone for single- or double-sided architectural concrete anchorings CB.
Creates a recess for Arch. Mounting Cone M24 and Concrete Cone DK 58/52.

Note
Plastic version.

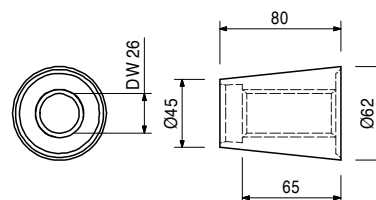
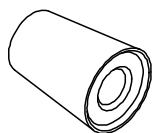

Accessories

115499 0.878 **Leading Cone Screw DW 26**

Item no.	Weight kg
125512	0.966

Arch. Leading Cone M24/DW 26 Steel

Leading cone for single- or double-sided architectural anchorings CB.
Creates a recess for Arch. Mounting Cone M24 and concrete cone DK 58/52.
Can also be used as shear cone for anchoring FB or KG Brackets.

Note

Steel version.
Seperate design information on request.

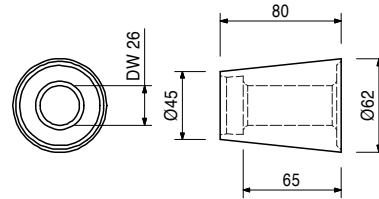
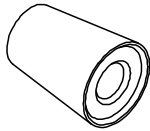

Accessories

115499	0.878
--------	-------

Leading Cone Screw DW 26

125963	3.100
--------	-------

Arch. Anchor Sleeve M24-150/1

Anchor sleeve for single-sided architectural concrete anchoring CB.
Anchor Tie DW 15 is passing through.
Plate size 150 mm.

Note

Seperate design information on request.

Technical Data

Fixed embedment depth 170 mm.
Min. wall thickness 200 mm.

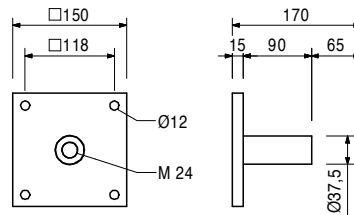
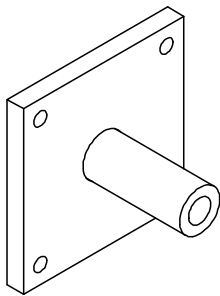

Accessories

065027	0.359
065033	0.010

Spacer Tube rough DR 22, l = 2.00 m Cone DR 22

114606	1.630
--------	-------

Arch. Mounting Cone M24

For anchoring climbing systems compatible with Mounting Ring M24.
Fixation to Arch. Anchor Sleeves M24-120/2, M24-150/2 or M24-150/1.

Note

Seperate design information on request.

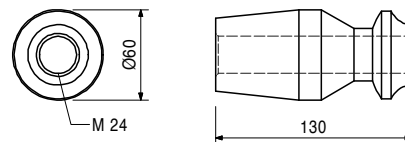
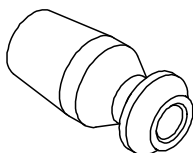

Accessories

057138	0.665
--------	-------

Hex. Bolt ISO 4014 M24 x 160-8.8, galv.

Item no.	Weight kg
057138	0.665

Hex. Bolt ISO 4014 M24 x 160-8.8, galv.

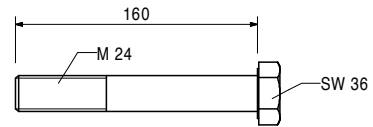
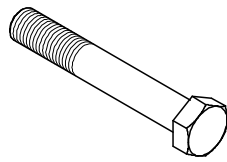

031642	0.152
--------	-------

DK Concrete Cone DW 15-58/30

For closing anchor points with DK Sealing Cone DW 15/35, DW 15/55, DW 20/55, DW 26/55, SK Anchor Cone DW 15, Magnet Cone MX 15 – 55, Magnet Cone MX 18 – 55, Arch. Leading Cone M24.

Note

Delivery unit 50 pieces.

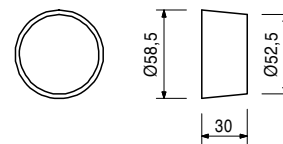
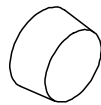

031643	0.241
--------	-------

DK Concrete Cone UNI 58/52

For closing anchor points with DK Sealing Cone DW 15/55, DW 20/55, DW 26/55, SK Anchor Cone DW 15, Magnet Cone MX 15 – 55, Magnet Cone MX 18 – 55, Arch. Leading Cone M24.

Note

Delivery unit 50 pieces.

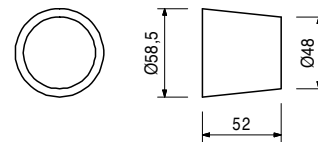
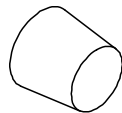

031641	0.208
--------	-------

DK Concrete Cone Architec. DW 15-58/52

For closing anchor points with DK Sealing Cone DW 15/55, DW 20/55, DW 26/55, SK Anchor Cone DW 15, Magnet Cone MX 15 – 55, Magnet Cone MX 18 – 55, Arch. Leading Cone M24 with corresponding architectural requirements.

Note

Delivery unit 50 pieces.

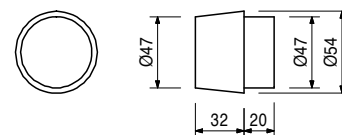
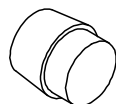



PERI Norge AS
Forskaling Stillas Engineering
Orhusveien 6
3070 Sande i Vestfold
Norge
Tel. +47 32 20 49 40
info@peri.no
www.peri.no