

# VARIOKIT VST

## Heavy-Duty Shoring Tower

Instructions for Assembly and Use – Standard Configuration – Edition 10/2019

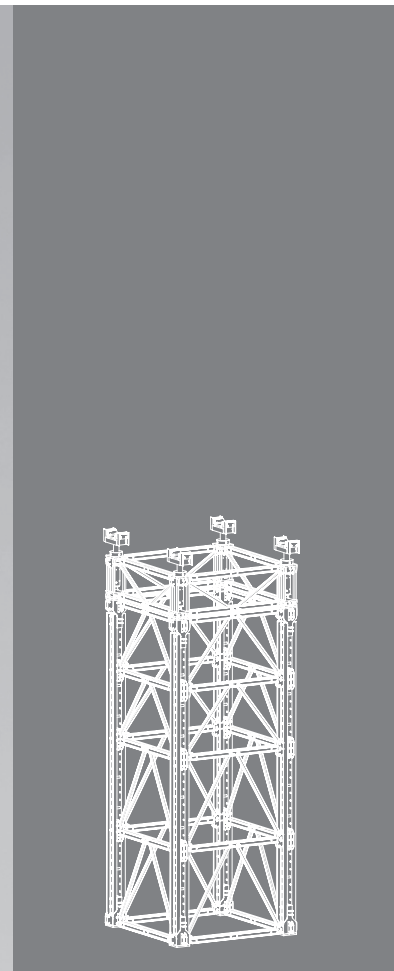

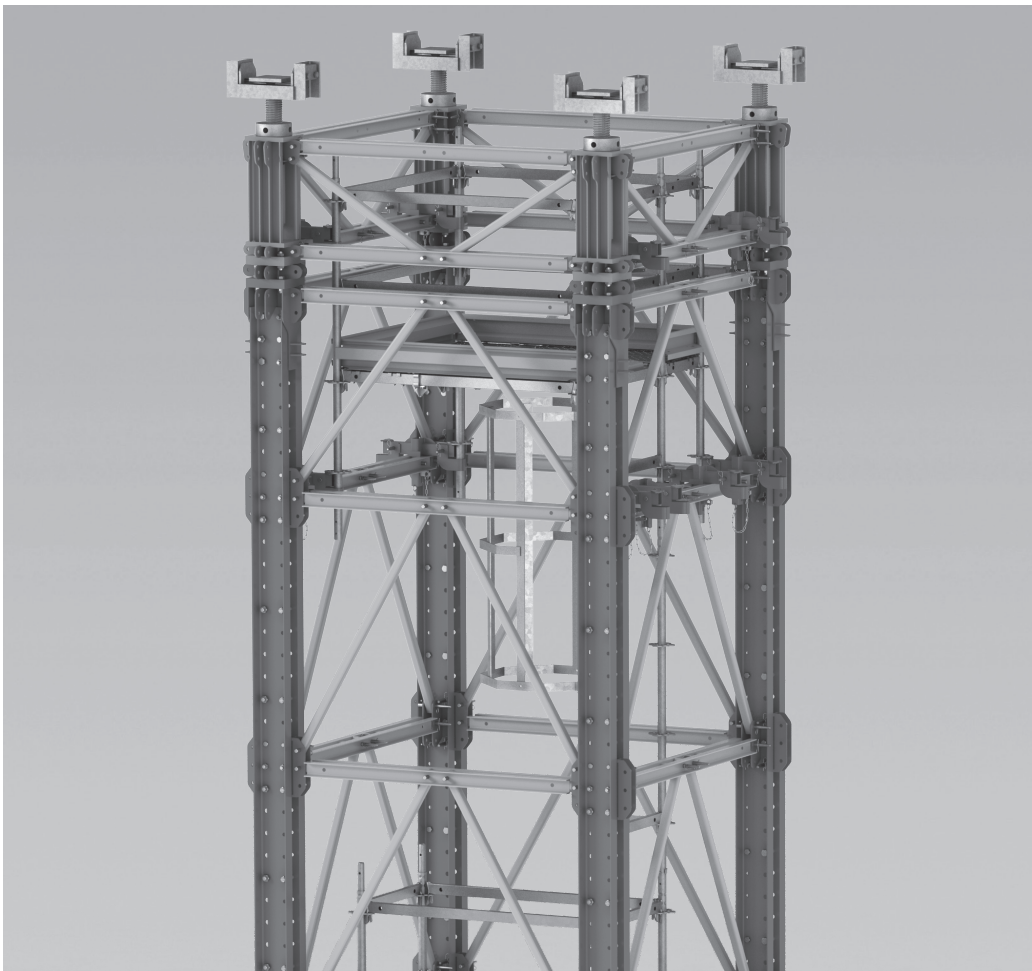

## Main components

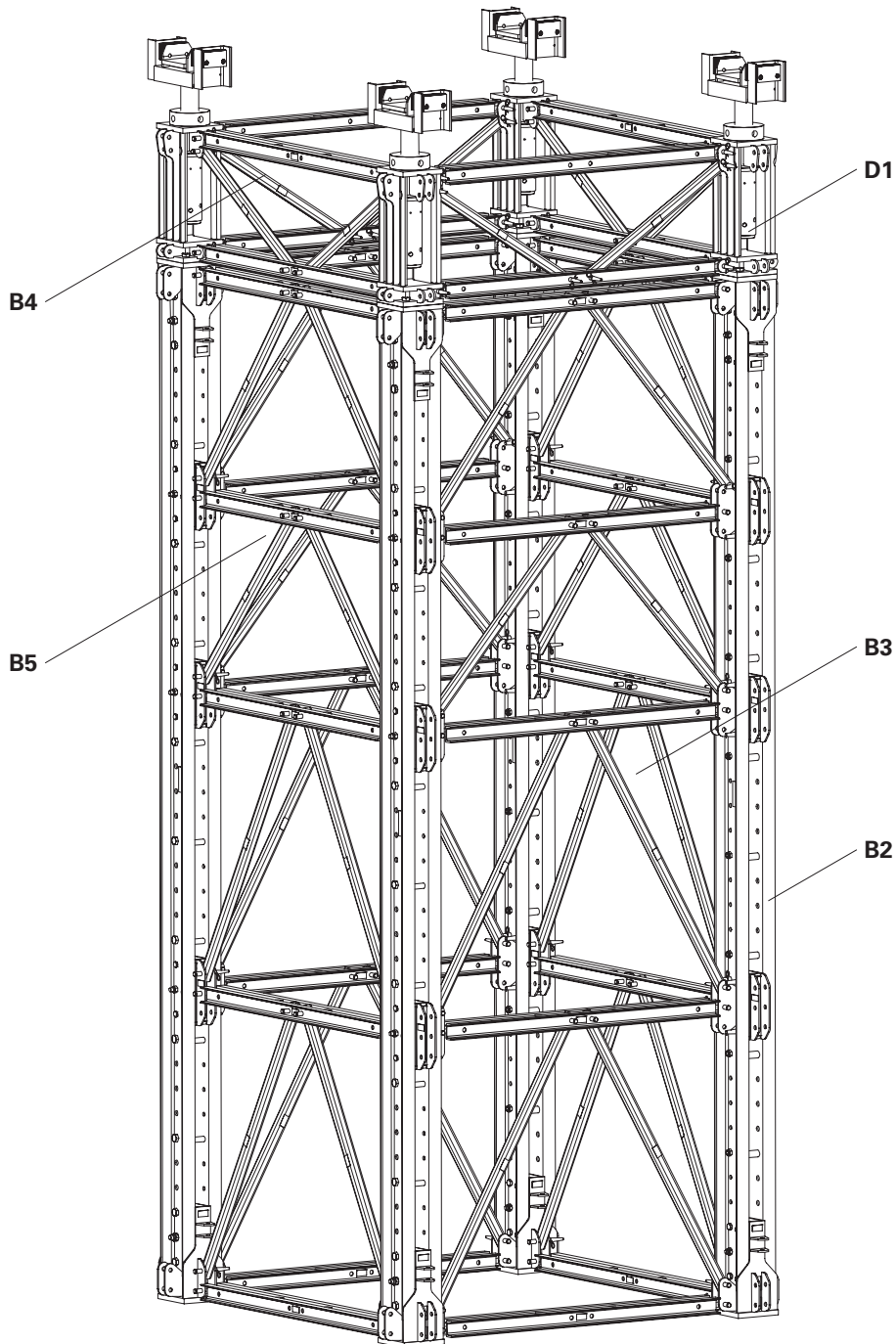

- B2 Assembly of the VST leg
- B3 Module assembly
- B4 Head spindle frame
- B5 Assembling the tower
- D1 Height adjustment head spindle VST (+/- 140 mm)

## Key

### Pictogram | Definition

Danger / warning / caution

Note

To be complied with

Load-bearing point

Visual check

Tip

Incorrect use

Safety helmet

Safety shoes

Safety gloves

Safety goggles

Personal protective equipment to prevent falling from a height (PPE)

### Arrows

Arrow representing an action

Arrow representing a reaction of an action\*

Arrow representing forces

\* If not identical to the action arrow.

### Safety instruction categories

The safety instructions alert site personnel to the risks involved and provide information on how to avoid these risks. Safety instructions are featured at the beginning of the section or ahead of the instructions, and are highlighted as follows:

#### **Danger**

This sign indicates an extremely hazardous situation which, if not avoided, will result in death or serious, irreversible injury.

#### **Warning**

This sign indicates a hazardous situation which, if not avoided, could result in death or serious, irreversible injury.

#### **Caution**

This sign indicates a hazardous situation which, if not avoided, could result in minor or moderate injury.

#### **Note**

This sign indicates situations in which failure to observe the information can result in material damage.

### Format of the safety instructions

#### **Signal word**

Type and source of hazard!  
Consequences of non-compliance.  
⇒ Preventative measures.

### Dimensions

Dimensions are usually given in cm. Other measurement units, e.g. m, are shown in the illustrations.

### Conventions

- Instructions are numbered with: 1. ...., 2. ...., 3. ....
- The result of an instruction is shown by: →
- Position numbers are clearly provided for the individual components and are given in the drawing, e.g. **1**, in the text in brackets, for example **(1)**.
- Multiple position numbers, i.e. alternative components, are represented with a slash: e.g. **1/2**.

### Notes on illustrations

The illustration on the front cover of these instructions is understood to be a system representation only. The assembly steps presented in these Instructions for Assembly and Use are shown in the form of examples with only one component size. They are valid for all component sizes contained in the standard configuration.

To facilitate understanding, detailed illustrations are sometimes incomplete. The safety installations which have possibly not been shown in these detailed illustrations must nevertheless be available.

## Target groups

### Contractors

These Instructions for Assembly and Use are designed for contractors who

- assemble, modify and dismantle the scaffolding, or
- use it, e.g. for concreting, or
- allow it to be used, e.g. for forming operations.

### Competent person

(Construction Site Coordinator)

The Safety and Health Protection Coordinator\*

- is appointed by the client,
- must identify potential hazards during the planning phase,
- determines measures that provide protection against risks,
- creates a safety and health protection plan,
- coordinates the protective measures for the contractor and site personnel so that they do not endanger each other,
- monitors compliance with the protective measures.

### Competent person qualified to carry out inspections

Due to the specialist knowledge gained from professional training, work experience and recent professional activity, the competent person qualified to carry out inspections has a reliable understanding of safety-related issues and can carry out inspections correctly. Depending on the complexity of the inspection to be undertaken, e.g. scope of testing, type of testing or the use of certain measuring devices, a range of specialist knowledge is necessary.

### Qualified personnel

The scaffolding may only be assembled, modified or dismantled by personnel who are suitably qualified to do so. Qualified personnel must have completed a course of training\*\* in the work to be performed, covering the following points at least:

- Explanation of the plan for the assembly, modification or dismantling of the scaffolding in an understandable form and language.
- Description of the measures for safely

assembling, modifying or dismantling the scaffolding.

- Naming of the preventative measures to be taken to avoid the risk of persons and objects falling.
- Designation of the safety precautions in the event of changing weather conditions that could adversely affect the safety of the scaffolding, as well as the personnel concerned.
- Details regarding permissible loads.
- Description of all other risks and dangers associated with assembly, modification or dismantling operations.



- **In other countries, ensure that the relevant national guidelines and regulations in the respective current version are complied with!**
- **If no country-specific regulations are available, it is recommended to proceed according to German guidelines and regulations.**
- **A competent person must be present on site during scaffolding operations.**

\* Valid in Germany: Regulations for Occupational Health and Safety on Construction Sites 30 (RAB 30)

\*\* Instructions are given by the contractor himself or a competent person selected by him.

---

## Additional technical documentation

- Instructions for Assembly and Use
  - PERI UP Flex
- Instructions for Use
  - Pallets and stacking devices
  - Hydraulic head spindle unit VST
- Brochure
  - VARIOKIT Engineering Construction Kit

## Intended use

### Product description

PERI products have been designed for exclusive use in the industrial and commercial sectors only by suitably trained personnel.

The VST Heavy-Duty Shoring Tower can transfer high loads from the formwork, for in-situ concrete bridges and all temporary support constructions for structural components.

The system can be used for all types of supporting structures, with a permissible leg load of up to 700 kN (height-dependent).

Through the use of the hydraulic head spindle device VST, the system allows adjustment of the head spindle under full load.

The VST Heavy-Duty Shoring Tower is a standard system which offers the possibility to support bridge formwork on girders or truss girders, prefabricated elements and other temporary load situations.

### Criteria

Main components are standardised PERI components taken from the VARIOKIT Engineering Construction Kit.

The base of the structure is formed by two parallel legs consisting of RCS climbing rails which are connected to each other by means of horizontal ledgers VST 200 and diagonal struts VST at a centre distance of 2 m.

The climbing rail RCS is additionally braced between the U-profiles with bracing connectors VST at a distance of max. 1.5 m upwards in order to increase the bending stiffness in the weak axis.

The connection in the longitudinal direction of the module is carried out with the prop base VST 48 and prop connector VST 48.

The module can be configured with horizontal ledgers VST 200 and diagonal struts VST to form a tower.

The flexible adaptation for achieving the required height can be carried out using modules VST 125 to VST 1025 in increments of 25 cm (see Section F Work Preparation).

Fine adjustment of  $\pm 140$  mm is possible with the head spindle VST.

### System dimensions

Axis dimension of the standard configuration

- 2 m x 2 m
- Height: Continuously variable for other configurations, see Section A12 to A15.

### Permissible load-bearing capacity

- Up to 700 kN (height-dependent) per leg.

## Instructions for use

Use in a way not intended, deviating from the standard configuration or the intended use according to the Instructions for Assembly and Use, represents a misapplication with a potential safety risk, e.g. risk of falling.

Deviations from the standard configuration must be verified for the application by means of separate strength and stability calculations (Industrial Safety Regulation Appendix 1, No. 3.2.1 and explicitly reflected in the assembly instructions.)

Only PERI original components may be used. The use of other products and spare parts is not allowed.

Changes to PERI components are not permitted.

The system described in these Instructions for Assembly and Use may contain patent-protected components.

## Cleaning and maintenance instructions

Clean the panels after each use to maintain the value and usability of the PERI products over the long term.

Some repair work may also be inevitable due to the tough working conditions. The following points should help to keep cleaning and maintenance costs as low as possible.

Never use steel brushes or hard metal scrapers to clean powder-coated or galvanised components.

Mechanical components, e.g. spindles, must be cleaned of dirt or concrete residue before and after use, and then greased with a suitable lubricant.

Provide suitable support for the components during cleaning so that no unintentional change in their position is possible.

Do not clean components suspended on crane lifting gear.

Any repairs to PERI products are to be carried out by PERI qualified personnel only.

## Cross-system

### General

The contractor must ensure that the Instructions for Assembly and Use supplied by PERI are available at all times and understood by the site personnel.

These Instructions for Assembly and Use can be used as the basis for creating a risk assessment. The risk assessment is compiled by the contractor. However, these Instructions for Assembly and Use do not replace the risk assessment!

Refer to and comply with the safety instructions and permissible loads.

For the application and inspection of PERI products, the current safety regulations and guidelines valid in the respective countries must be observed.

Materials and working areas are to be inspected on a regular basis, especially before each use and assembly, for:

- damage,
- stability and
- functional correctness.

Damaged components must be exchanged immediately on site and may no longer be used.

Safety components are to be removed only when they are no longer required.

Components provided by the contractor must comply with the characteristics stipulated in these Instructions for Assembly and Use and all applicable laws and standards. Unless otherwise indicated, the following applies in particular:

- timber components: Strength Class C24 for solid wood according to EN 338.
- scaffold tubes: galvanised steel tubing with minimum dimensions  $\varnothing 48.3 \times 3.2$  mm according to EN 12811-1:2003 4.2.1.2.
- scaffold tube couplings according to EN 74.

Deviations from the standard configuration are only permitted after a further risk assessment has been carried out by the contractor.

Appropriate measures for working and operational safety, as well as stability,

are defined on the basis of this risk assessment.

Corresponding proof of stability can be provided by PERI on request if the risk assessment and resulting measures to be implemented are made available.

Before and after exceptional occurrences that may have an adverse effect on the safety of the scaffolding system, the contractor must immediately

- produce another risk assessment and make use of its results to take suitable steps to guarantee the stability of the scaffolding system,
- arrange for an extraordinary inspection to be carried out by a competent person qualified to do so. The aim of this inspection is to identify and rectify any damage in good time in order to guarantee safe use of the scaffolding system.

Exceptional events could be:

- accidents,
- long periods of non-use,
- natural events, e.g. heavy rainfall, icing, heavy snowfall, storms or earthquakes.

### assembly, modification and dismantling work

Assembly, modification or dismantling of scaffolding systems may only be carried out by qualified persons under the supervision of a competent person. The qualified personnel must have received appropriate training for the work to be carried out with regard to specific risks and dangers.

On the basis of the risk assessment and the Instructions for Assembly and Use, the contractor must create installation instructions to ensure safe assembly, modification and dismantling of the shoring system.

Before initial use, the safe functioning of the scaffold must be checked by a person qualified to carry out the inspection.

The results of the inspection must be documented in an inspection record.

The contractor must ensure that the personal protective equipment required for the assembly, modification or dismantling of the shoring system, e.g.

- safety helmet,
  - safety shoes,
  - safety gloves,
  - safety goggles
- is available and used as intended.

If personal protective equipment against falling from a height (PPE) is required or specified in local regulations, the contractor must determine appropriate attachment points on the basis of the risk assessment.

The PPE against falling to be used is determined by the contractor.

The contractor must

- provide safe working areas for site personnel, which are to be reached through the provision of safe access ways. areas of risk must be cordoned off and clearly marked.
- ensure stability during all stages of construction, in particular during assembly, modification and dismantling operations.
- ensure and provide evidence that all loads that occur are transferred safely.

### Use

Every contractor who uses or allows the scaffolding systems or sections of the scaffolding system to be used, is responsible for ensuring that the equipment is in good condition.

If the scaffolding system is used successively or at the same time by several contractors, the health and safety coordinator must point out any possible mutual hazards and all work must be then coordinated.



## System-specific

The components are to be inspected for signs of damage by authorised personnel at regular intervals.

Dirt which affects the functionality is to be removed immediately.

Damaged components are to be inspected, removed and replaced.

For information regarding the maintenance of the hydraulic head spindle device VST, see Instructions for Use.



Detailed project-specific static proof as well as planning is required for each time of use.

In addition, project-specific lifting and lowering plans are to be created.

Lifting or lowering operations only take place if a competent person has given the go-ahead and the upper construction has sufficient load-bearing capacity.

All screw connections are to be secured with suitable nuts.

All fitting pin connections are to be secured with cotter pins.

## Storage and transportation

Store and transport components ensuring that no unintentional change in their position is possible. Detach lifting accessories and slings from the lowered components only if they are in a stable position and no unintentional change is possible.

Do not drop the components.

Use PERI lifting accessories and slings and only those load-bearing points provided on the component.

During the moving procedure

- ensure that components are picked up and set down so that unintentional falling over, falling apart, sliding, falling down or rolling is avoided.
- no persons are allowed to remain under the suspended load.

Pre-assembled modules and towers are to be guided with ropes when moving them by crane.

The access areas on the construction site must be free of obstacles and tripping hazards, as well as being slip-resistant.

For transportation, the surface must have sufficient load-bearing capacity.

Use original PERI storage and transport systems, e.g. pallet cages, pallets or stacking devices.

## Overview of module VST

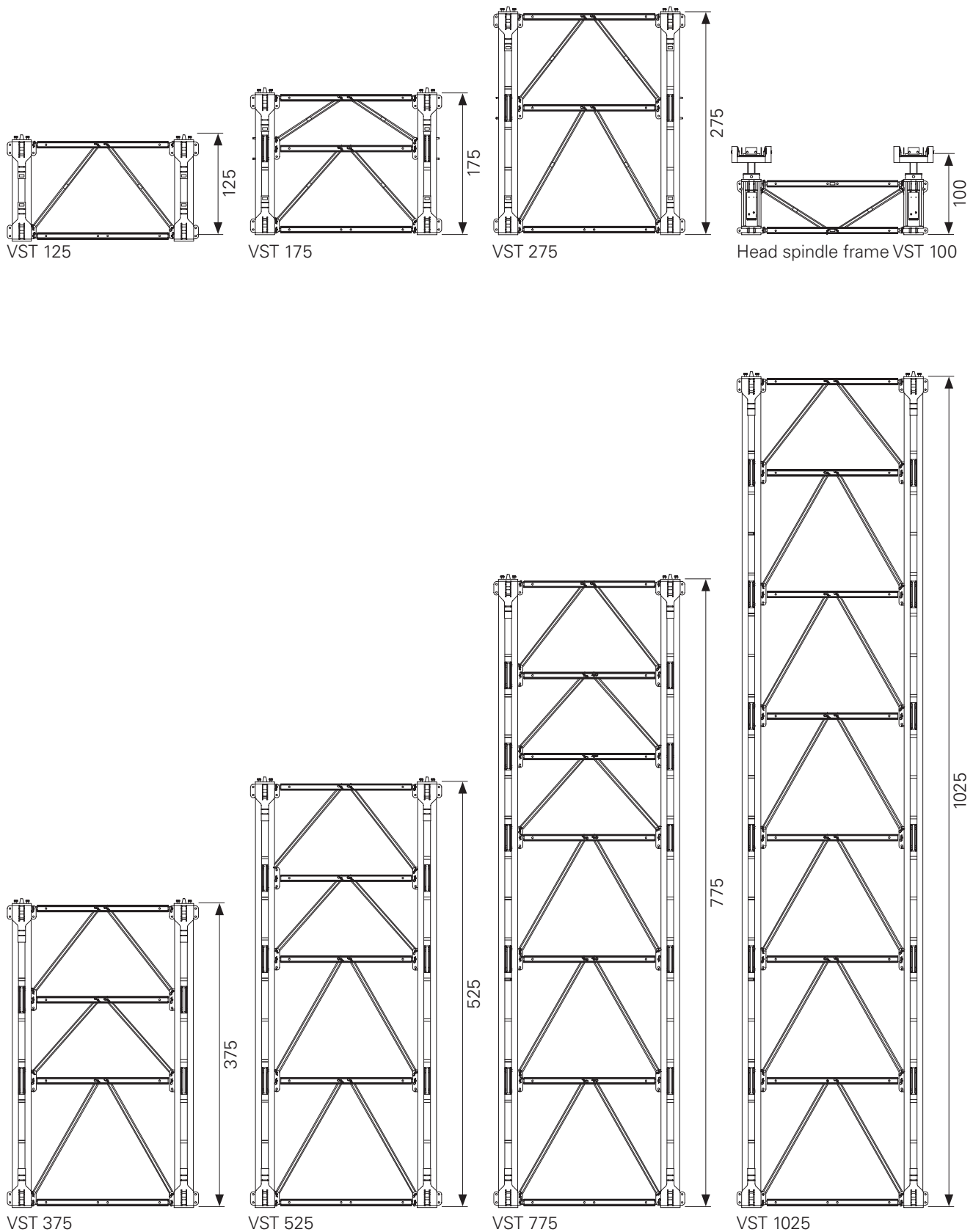

Fig. A1.01

## Arrangement of the bracing connectors VST



Observe the assembly position of the prop base VST and prop connector VST. (See Section B2, assembly of the VST leg)

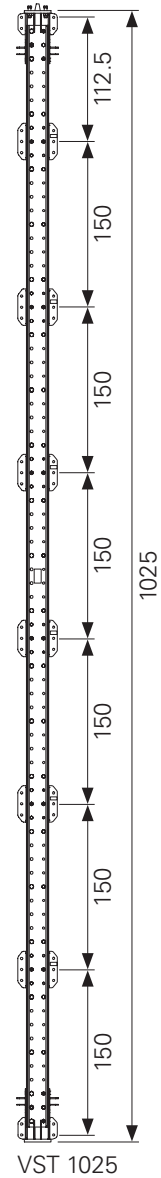
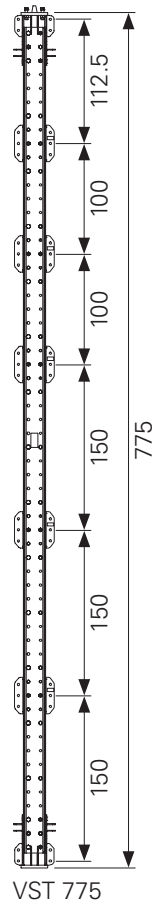
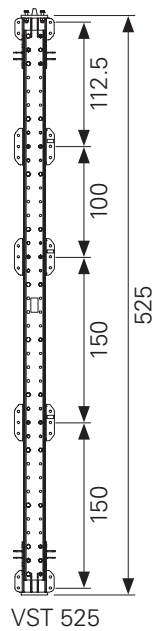
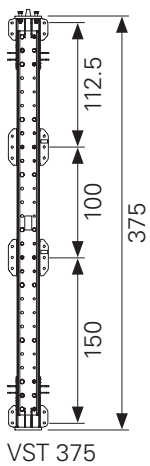
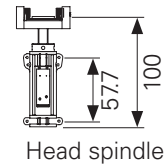
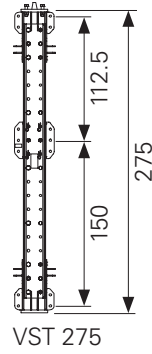
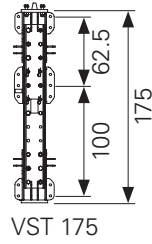
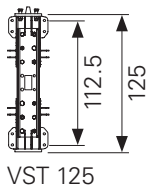

Fig. A1.02

## Module VST components

	Name	Art. no.
<b>VST legs consist of</b>		
1	Climbing rail profile RCS 98	117585
2	Climbing rail RCS 148	114166
3	Climbing rail RCS 248	109469
4	Climbing rail RCS 348	109470
5	Climbing rail RCS 498	109471
6	Climbing rail RCS 748	109472
7	Climbing rail RCS 998	109610
<b>The VST modules consist of 2 VST legs plus</b>		
8	Bracing connector VST	117411
9	Fitting pin Ø 21 x 120	104031
10	Cotter pin 4/1, galv.	018060
11	Fitting pin Ø 26 x 120	111567
12	Cotter pin 5/1, galv.	022230
13	Cross connector VST	117425
14	Bolt ISO 4014 M20 x 140-8.8, galv.	113994
15	Nut ISO 7042 M20-8, galv.	781053
16	Sleeve VST, galv.	117492
17	Prop base VST 48	117453
18	Bolt ISO 4014 M20 x 130-10.9	117452
19	Bolt ISO 4014 M24 x 140-10.9	114563
20	Nut ISO 7042 M24-8, galv.	105032
21	Prop connector VST 48	117454
22	Bolt ISO 4014 M24 x 80-8.8, galv.	105416
23	Horizontal ledger VST 200	117371
24	Diagonal strut VST 200/150	117379
25	Diagonal strut VST 200/100	117382
26	Diagonal strut VST 200/112.5	117385
27	Diagonal strut VST 200/62.5	117388

Tab. A1.01

## Additional components

	Name	Art. no.
28	Head spindle VST 100	117465
28.1	U-head	
28.2	Spindle nut	
28.3	Spindle sleeve	
29	Mounting shaft VST	117377
30	SLS heavy-duty spindle	
31	Push-pull prop RS 1000, galv.	028990
32	Push-pull prop RS 1400, galv.	103800
33	Steel waler universal SRU U120	
34	Adapter VST-SRU	123823
35	Bolt ISO 4014 M16 x 100-10.9	Special
36	Sleeve Ø 21 x 2, L = 29 mm	Special
37	Cyl. Bolt ISO 4762 M20 x 150-8.8, galv.	118256
38	Connector UP-VST	117707
38.1	Retaining lug	
39	Pin Ø 20 x 140, galv.	105400
40	PERI wedge K, galv.	024250
41	Leg connector VST 200/37.5	117712
42	Horizontal connector VST 37.5	117696
43	Hydraulic unit VST 75	117678
43.1	Hydraulic hose	
43.2	Hand pump	
43.3	Manometer	
43.4	Hydraulic cylinder	
44	Height compensation VST 12.5	117391
45	Height compensation VST 25	117433
46.1	Vertical leg UVR 300	100012
46.2	Vertical leg UVR 150	102860
47	Ledger UH 150	400021
48	Steel waler SRZ U100	
49	Kicker brace AV	
50	Tie rod DW 15	
51	Cam nut DW 15, galv.	030130
52	Wingnut pivot plate DW 15, galv.	030370
53	Tie rod DW 26	
54	Counterplate DW 26	123825
55	Hex. coupler DW 26 SW 46/80, weldable	030970

Tab. A1.02

## Parts list for module VST 125

Pos.	Name	Quantity
1	Climbing rail profile RCS 98	4
9	Fitting pin $\varnothing$ 21 x 120	8
10	Cotter pin 4/1, galv.	8
15	Nut ISO 7042 M20-8, galv.	12
17	Prop base VST	2
18	Bolt ISO 4014 M20x130-10.9	12
19	Bolt ISO 4014 M24x140-10.9	12
20	Nut ISO 7042 M24-8, galv.	12
21	Prop connector VST 48	2
23	Horizontal ledger VST 200	2
26	Diagonal strut VST 200/112.5	2



Connecting means are pre-assembled in the VST components.

The total weight of a module VST 125 is 370.20 kg.

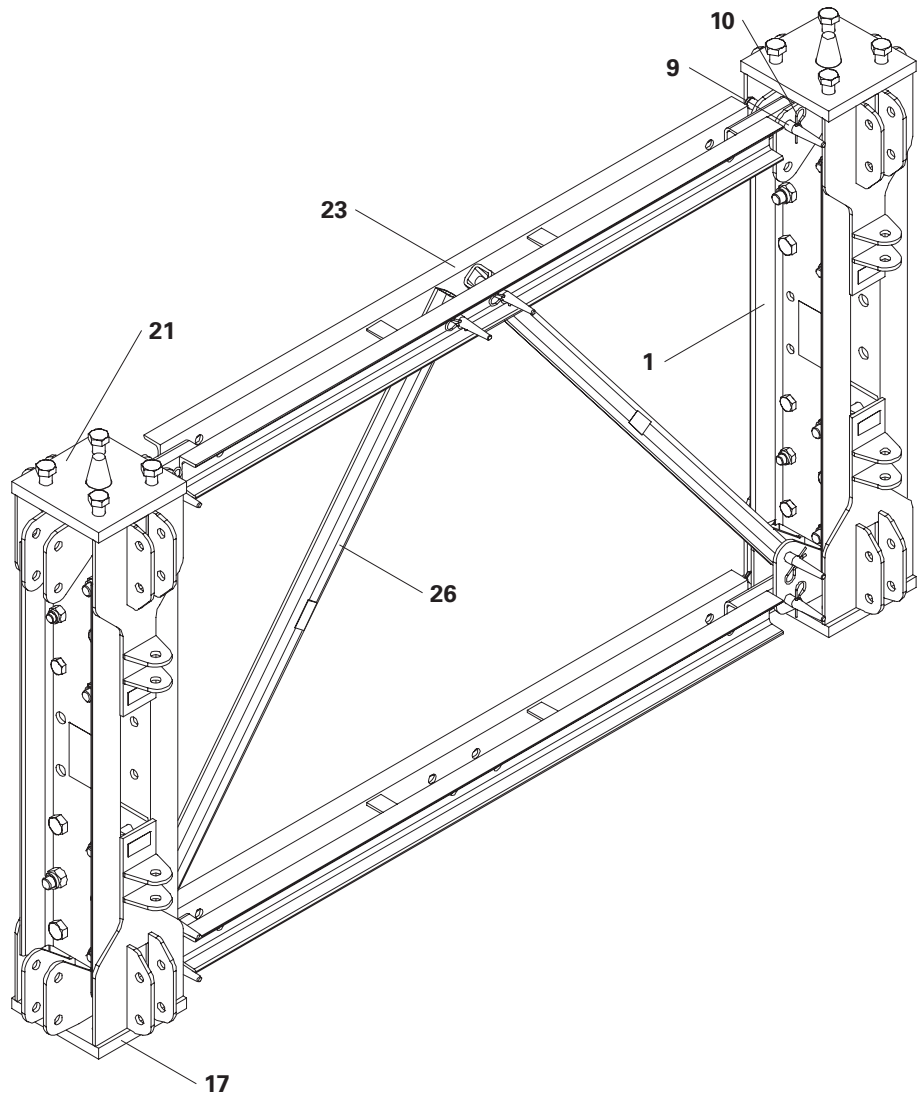

Fig. A2.01

## Parts list for module VST 175

Pos.	Name	Quantity
2	Climbing rail RCS 148	2
8	Bracing connector VST	2
9	Fitting pin $\varnothing$ 21 x 120	18
10	Cotter pin 4/1, galv.	18
11	Fitting pin $\varnothing$ 26 x 120	4
12	Cotter pin 5/1, galv.	4
13	Cross connector VST	2
14	Bolt ISO 4014 M20 x 140-8.8	4
15	Nut ISO 7042 M20-8	16
16	Sleeve VST	2
17	Prop base VST	2
18	Bolt ISO 4014 M20x130-10.9	12
19	Bolt ISO 4014 M24x140-10.9	12
20	Nut ISO 7042 M24-8	12
21	Prop connector VST 48	2
23	Horizontal ledger VST 200	3
25	Diagonal strut VST 200/100	2
27	Diagonal strut VST 200/62.5	2



Connecting means are pre-assembled in the VST components.

The total weight of a module VST 175 is 528.44 kg.

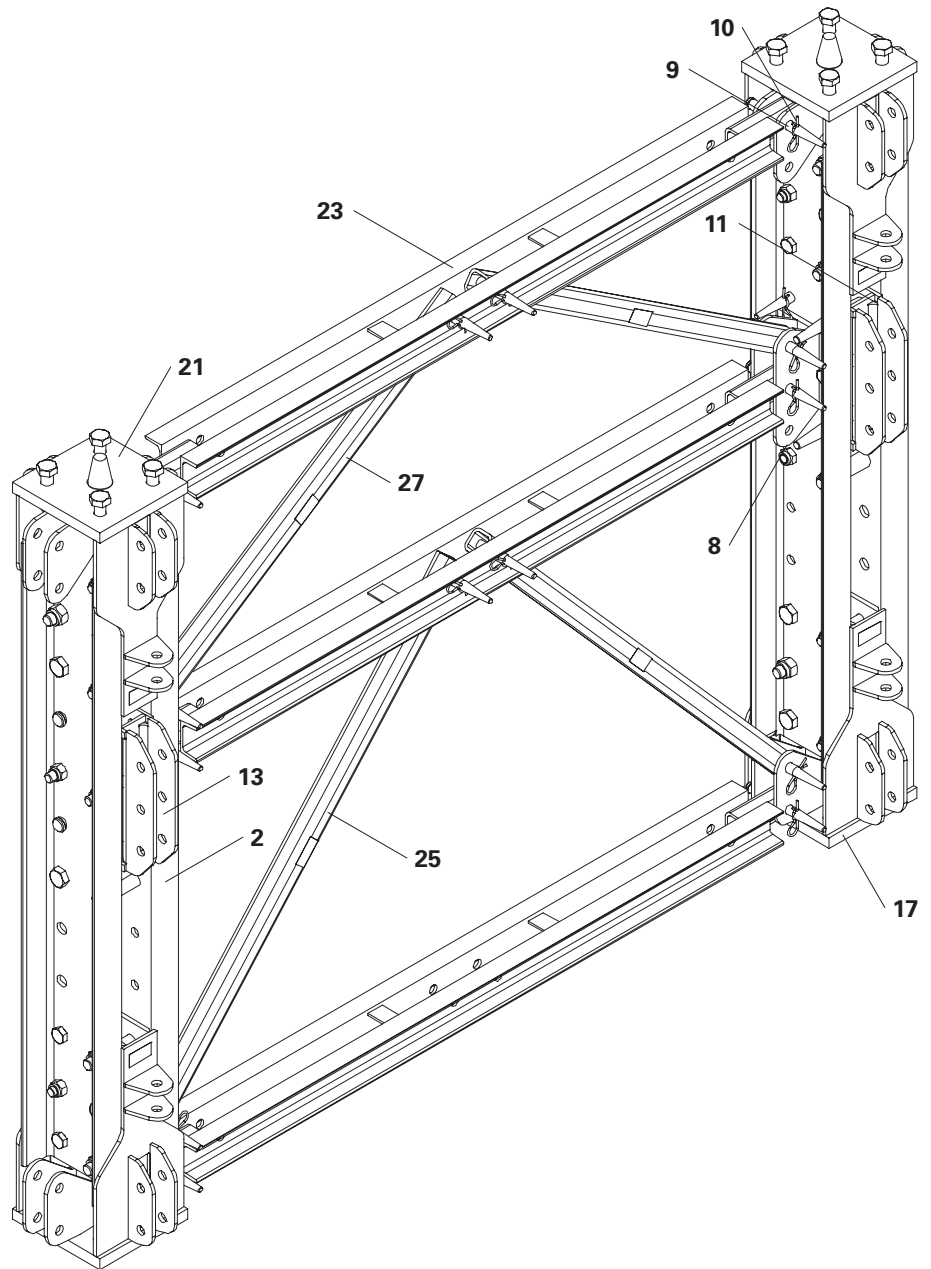

Fig. A3.01

## Parts list for module VST 275

Pos.	Name	Quantity
3	Climbing rail RCS 248	2
8	Bracing connector VST	2
9	Fitting pin Ø 21 x 120	18
10	Cotter pin 4/1, galv.	18
11	Fitting pin Ø 26 x 120	4
12	Cotter pin 5/1, galv.	4
13	Cross connector VST	2
14	Bolt ISO 4014 M20 x 140-8.8	4
15	Nut ISO 7042 M20-8	16
16	Sleeve VST	2
17	Prop base VST	2
18	Bolt ISO 4014 M20x130-10.9	12
19	Bolt ISO 4014 M24x140-10.9	12
20	Nut ISO 7042 M24-8	12
21	Prop connector VST 48	2
23	Horizontal ledger VST 200	3
24	Diagonal strut VST 200/150	2
26	Diagonal strut VST 200/112.5	2



Connecting means are pre-assembled in the VST components.

The total weight of a module VST 275 is 644.02 kg.

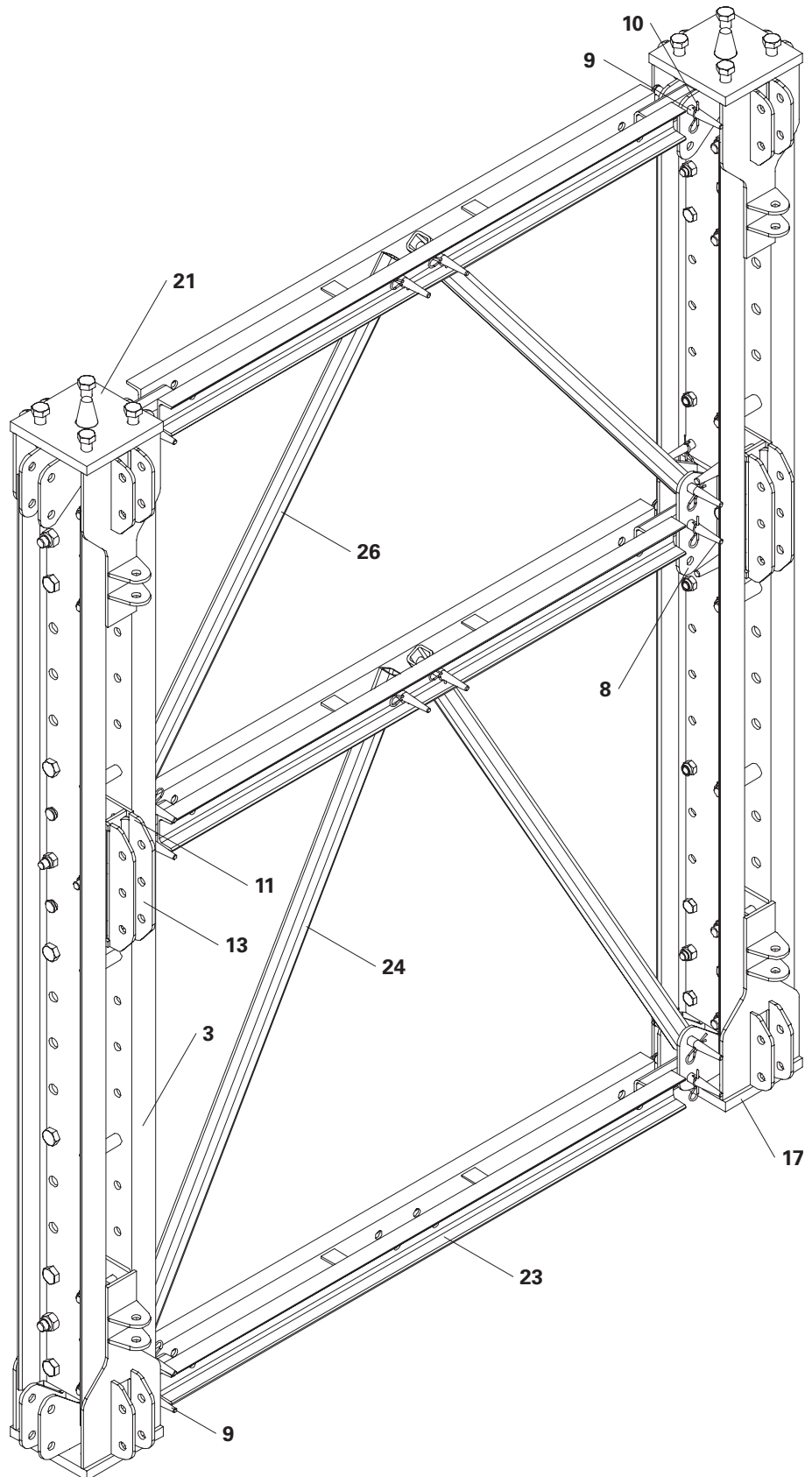

Fig. A4.01



## Parts list for module VST 375

Pos.	Name	Quantity
4	Climbing rail RCS 348	2
8	Bracing connector VST	4
9	Fitting pin $\varnothing$ 21 x 120	28
10	Cotter pin 4/1, galv.	28
11	Fitting pin $\varnothing$ 26 x 120	8
12	Cotter pin 5/1, galv.	8
13	Cross connector VST	4
14	Bolt ISO 4014 M20 x 140-8.8	8
15	Nut ISO 7042 M20-8	20
16	Sleeve VST	4
17	Prop base VST	2
18	Bolt ISO 4014 M20x130-10.9	12
19	Bolt ISO 4014 M24x140-10.9	12
20	Nut ISO 7042 M24-8	12
21	Prop connector VST 48	2
23	Horizontal ledger VST 200	4
24	Diagonal strut VST 200/150	2
25	Diagonal strut VST 200/100	2
26	Diagonal strut VST 200/112.5	2



Connecting means are pre-assembled in the VST components.

The total weight of a module VST 375 is 852.64 kg.

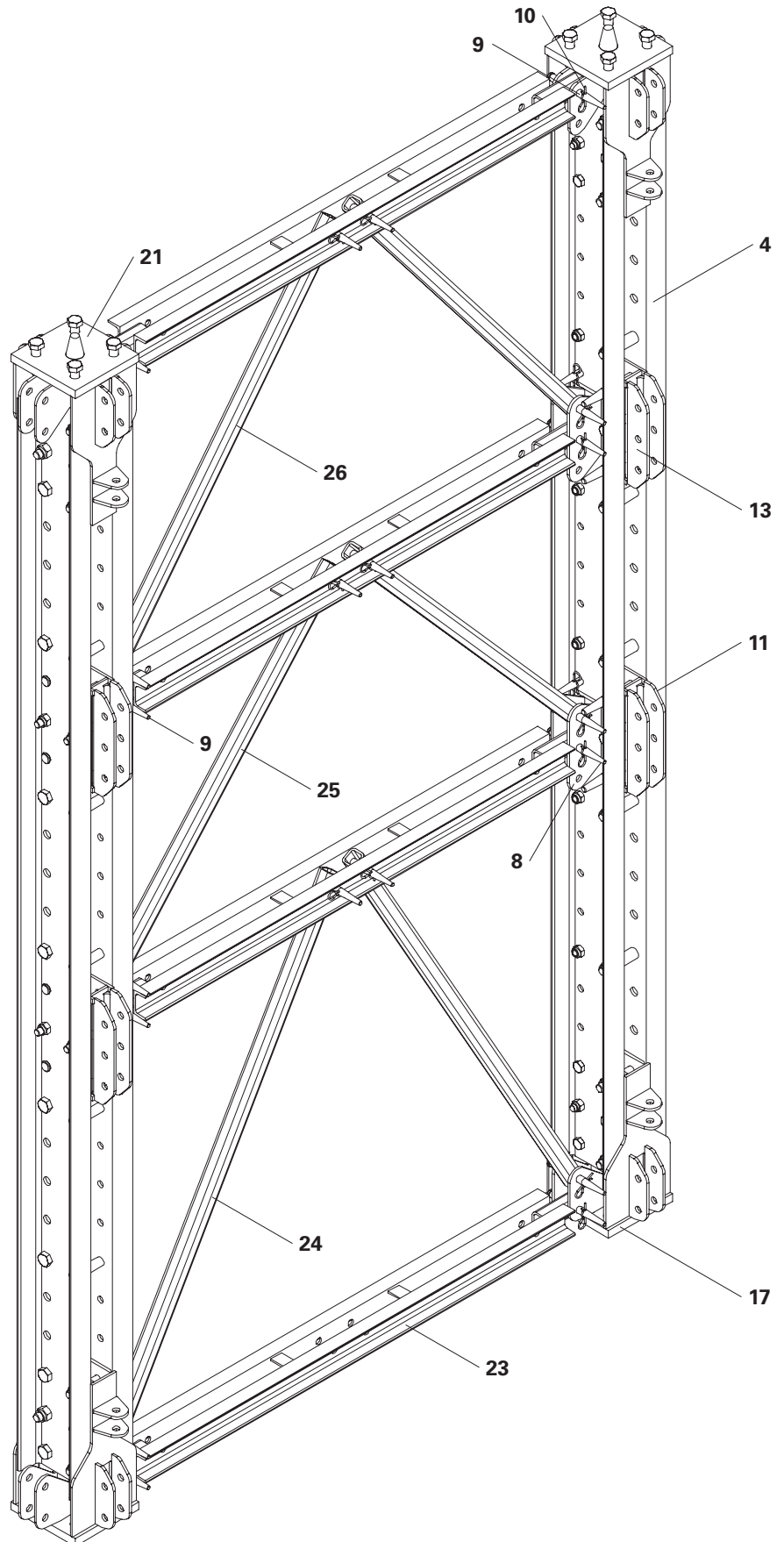

Fig. A5.01

## Parts list for module VST 525

Pos.	Name	Quantity
5	Climbing rail RCS 498	2
8	Bracing connector VST	6
9	Fitting pin $\varnothing$ 21 x 120	38
10	Cotter pin 4/1, galv.	38
11	Fitting pin $\varnothing$ 26 x 120	12
12	Cotter pin 5/1, galv.	12
13	Cross connector VST	6
14	Bolt ISO 4014 M20 x 140-8.8	12
15	Nut ISO 7042 M20-8	24
16	Sleeve VST	6
17	Prop base VST	2
18	Bolt ISO 4014 M20x130-10.9	12
19	Bolt ISO 4014 M24x140-10.9	12
20	Nut ISO 7042 M24-8	12
21	Prop connector VST 48	2
23	Horizontal ledger VST 200	5
24	Diagonal strut VST 200/150	4
25	Diagonal strut VST 200/100	2
26	Diagonal strut VST 200/112.5	2



Connecting means are pre-assembled in the VST components.

The total weight of a module VST 525 is 1123.66 kg.

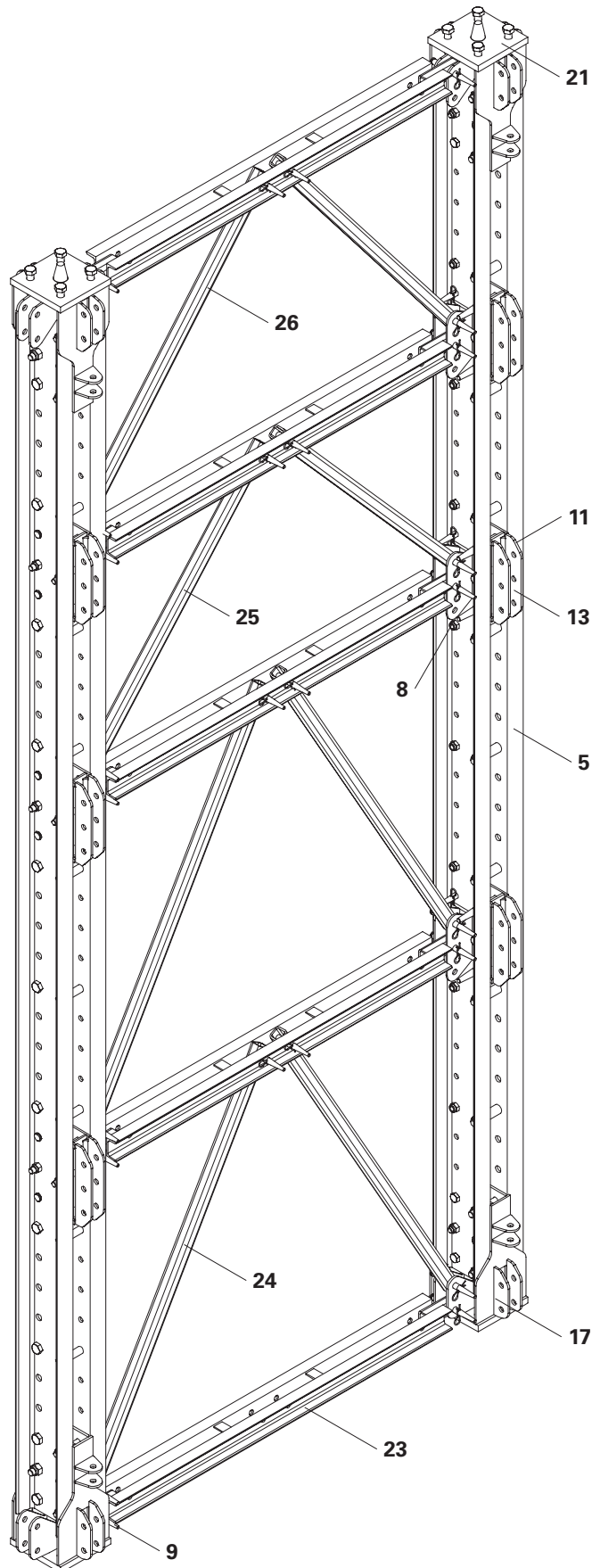

Fig. A6.01

## Parts list for module VST 775

Pos.	Name	Quantity
6	Climbing rail RCS 748	2
8	Bracing connector VST	10
9	Fitting pin $\varnothing$ 21 x 120	58
10	Cotter pin 4/1, galv.	58
11	Fitting pin $\varnothing$ 26 x 120	20
12	Cotter pin 5/1, galv.	20
13	Cross connector VST	10
14	Bolt ISO 4014 M20 x 140-8.8	20
15	Nut ISO 7042 M20-8	32
16	Sleeve VST	10
17	Prop base VST	2
18	Bolt ISO 4014 M20x130-10.9	12
19	Bolt ISO 4014 M24x140-10.9	12
20	Nut ISO 7042 M24-8	12
21	Prop connector VST 48	2
23	Horizontal ledger VST 200	7
24	Diagonal strut VST 200/150	6
25	Diagonal strut VST 200/100	4
26	Diagonal strut VST 200/112.5	2



Connecting means are pre-assembled in the VST components.

The total weight of a module VST 775 is 1601.30 kg.

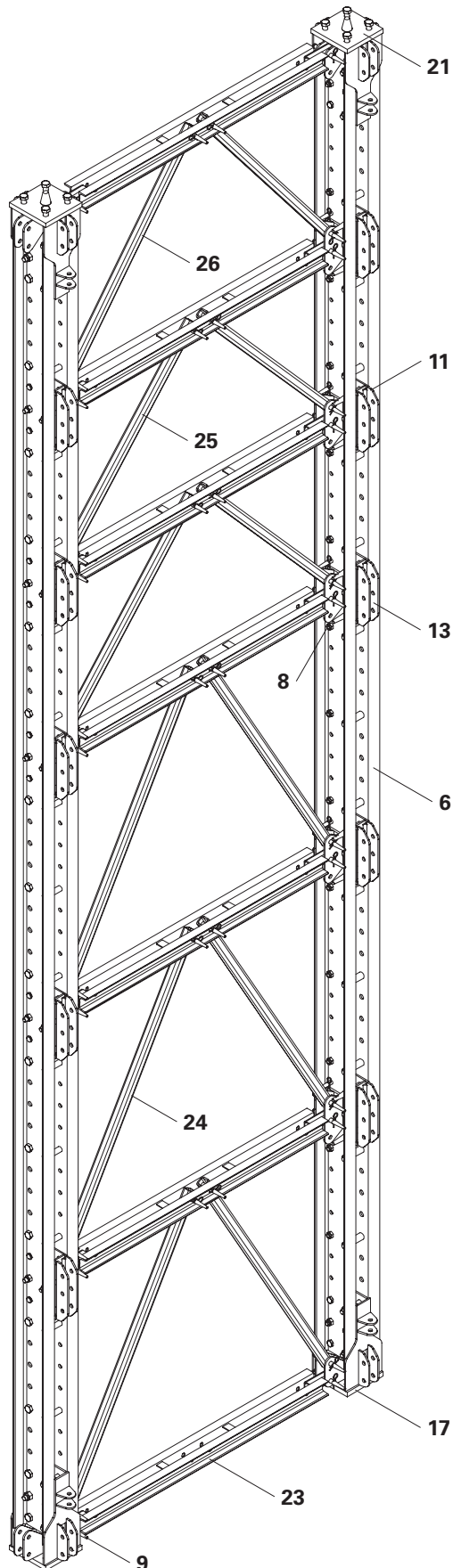

Fig. A7.01

## Parts list for module VST 1025

Pos.	Name	Quantity
7	Climbing rail RCS 998	2
8	Bracing connector VST	12
9	Fitting pin $\varnothing$ 21 x 120	68
10	Cotter pin 4/1, galv.	68
11	Fitting pin $\varnothing$ 26 x 120	24
12	Cotter pin 5/1, galv.	24
13	Cross connector VST	12
14	Bolt ISO 4014 M20 x 140-8.8	24
15	Nut ISO 7042 M20-8	36
16	Sleeve VST	12
17	Prop base VST	2
18	Bolt ISO 4014 M20x130-10.9	12
19	Bolt ISO 4014 M24x140-10.9	12
20	Nut ISO 7042 M24-8	12
21	Prop connector VST 48	2
23	Horizontal ledger VST 200	8
24	Diagonal strut VST 200/150	12
26	Diagonal strut VST 200/112.5	2



Connecting means are pre-assembled in the VST components.

The total weight of a module VST 1025 is 1,987.12 kg.

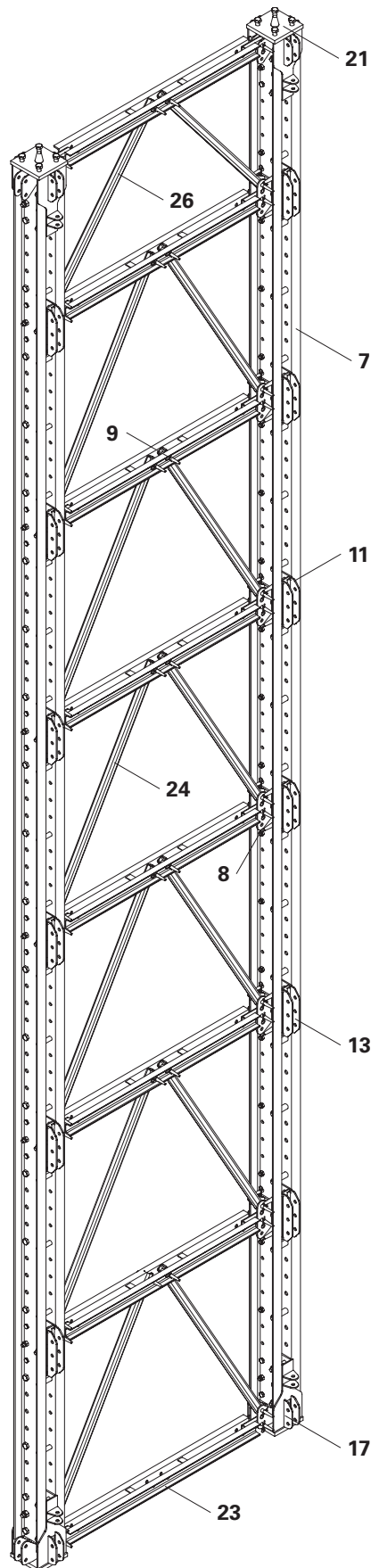

Fig. A8.01

## Parts list for the head spindle frame VST

Pos.	Name	Quantity
9	Fitting pin $\varnothing$ 21 x 120	8
10	Cotter pin 4/1, galv.	8
23	Horizontal ledger VST 200	2
27	Diagonal strut VST 200/62.5	2
28	Head spindle VST 100	2

The total weight of a head spindle frame VST is 424.62 kg.

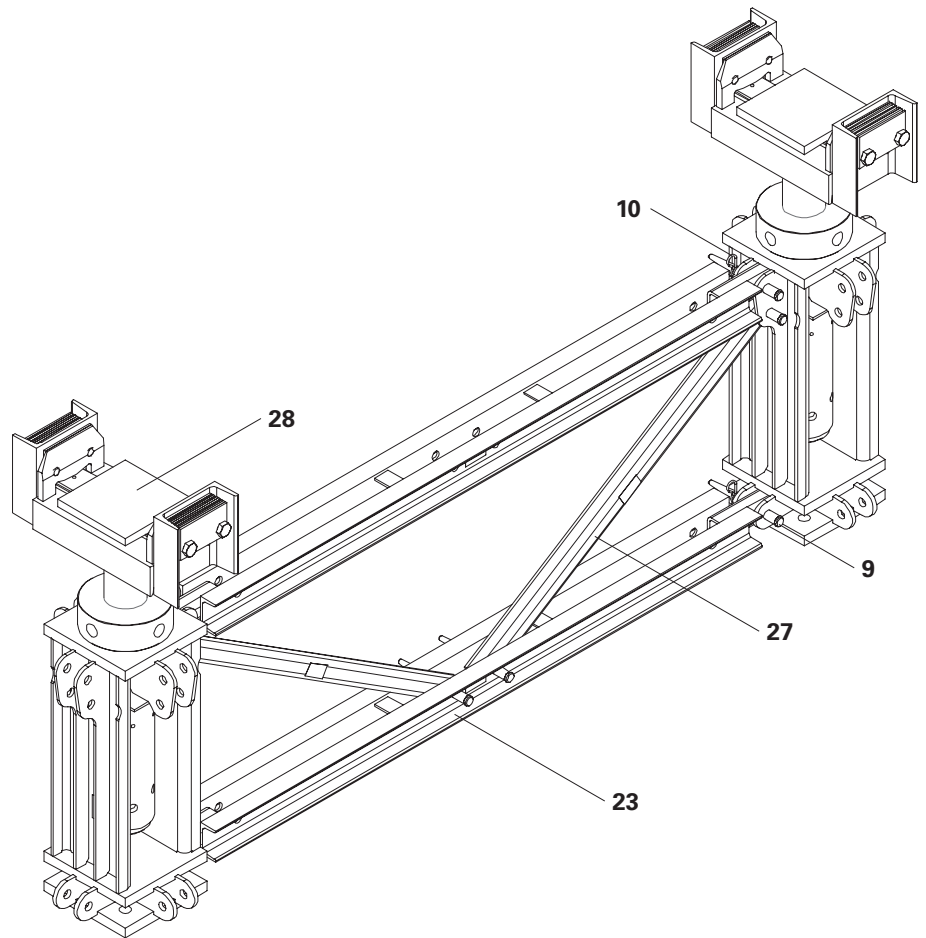

Fig. A9.01

## Parts list for a head spindle VST 100

Pos.	Name	Quantity
28	Head spindle VST 100	1
28.1	U-head	
28.2	Spindle nut	
28.3	Spindle sleeve	
29	Mounting shaft VST	1
43.4	Hydraulic cylinder	1

### Warning

The payload is only achieved if the maximum spindling length measured from the base plate of the head spindle to the top edge of the bearing plate does not exceed 1,138 mm.

Otherwise, this can result in serious injuries.

⇒ Holes in the spindle sleeve serve as a visual check. If the thread is visible through these holes, the head spindle is within the permissible range. If the thread cannot be seen, the permissible state must be established by means of suitable measures, e.g. packing under the main beams with compensating plates or installation of Height Adjusts VST 12.5 or 25, before the tower is loaded.



The mounting plate can be tilted by  $\pm 9^\circ$  in order to compensate for transverse gradients in the main beam.



Additional horizontal loads from the transverse gradients need to be taken into account statically.

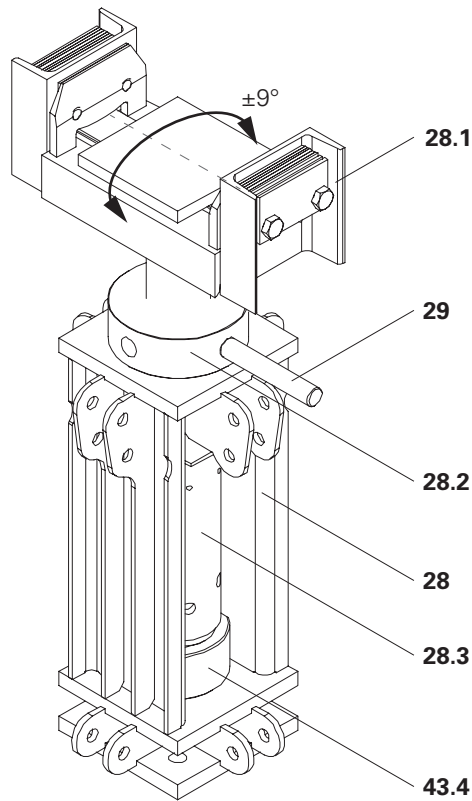

Fig. A10.01

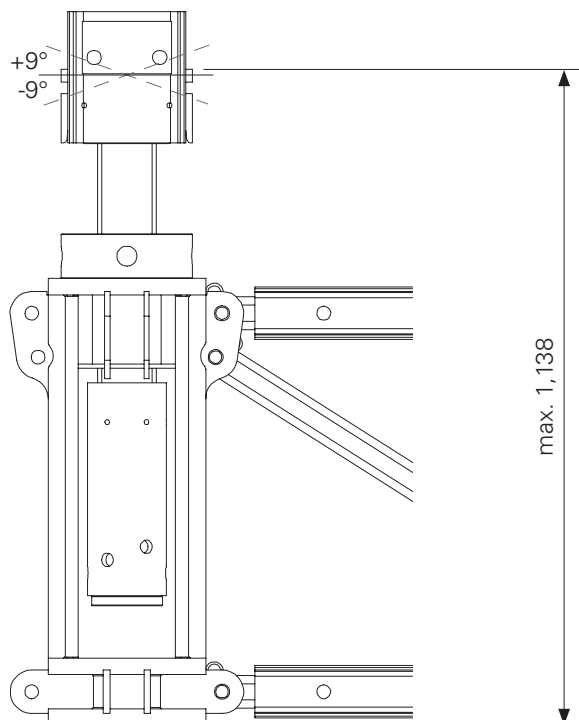

Fig. A10.01a

# A11 VST tower configuration 1

## Tower configuration 2.0 x 2.0 m

**Pos. Name**

9	Fitting pin Ø 21 x 120
10	Cotter pin 4/1, galv.
23	Horizontal ledger VST 200
24	Diagonal strut VST 200/150
25	Diagonal strut VST 200/100
26	Diagonal strut VST 200/112.5
27	Diagonal strut VST 200/62.5

## Total weight for one VST Tower (configuration 1)

Name	Overall weight (kg)
Tower 125	912.80
Tower 175	1,324.52
Tower 275	1,579.64
Tower 375	2,103.28
Tower 525	2,764.52
Tower 775	3,945.40
Tower 1025	4,861.48
Head spindle frame VST	1,010.48

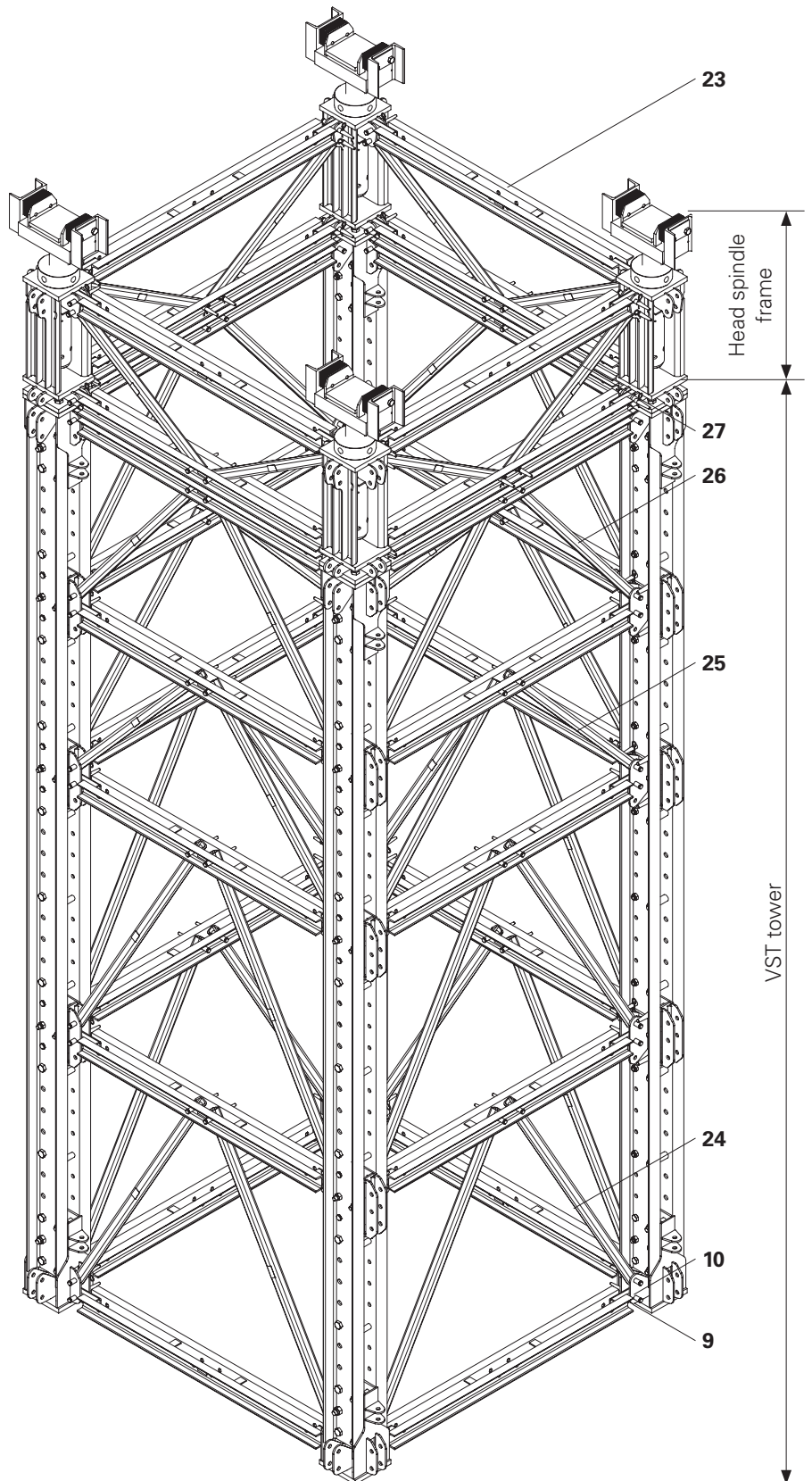

Fig. A11.01

## Tower configuration 2.0 x 1.0 m-4.5 m

Pos. Name

9	Fitting pin $\varnothing$ 21 x 120
10	Cotter pin 4/1, galv.
30	SLS heavy-duty spindle



Connecting means for heavy-duty spindles SLS must be ordered separately.

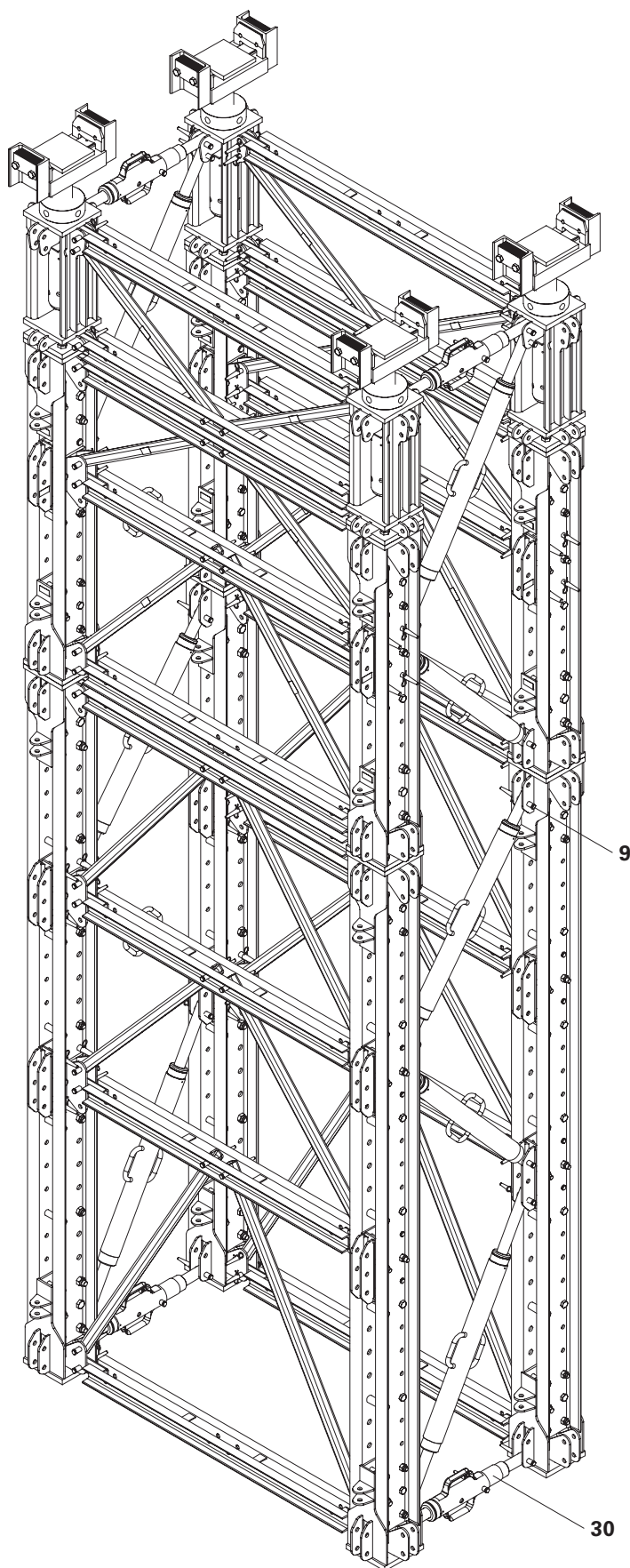

Fig. A12.01



# A13 VST tower configuration 3

## Tower configuration 1.25-6.5 x 1.0-4.5 m

Pos. Name

- |    |   |
|----|---|
| 9  | Fitting pin $\varnothing 21 \times 120$ |
| 10 | Cotter pin 4/1, galv.                   |
| 30 | SLS heavy-duty spindle                  |
| 33 | Steel waler universal SRU U120          |
| 34 | Adapter VST-SRU                         |



Connecting means for heavy-duty spindles SLS and steel waler universal SRU U120 must be ordered separately.

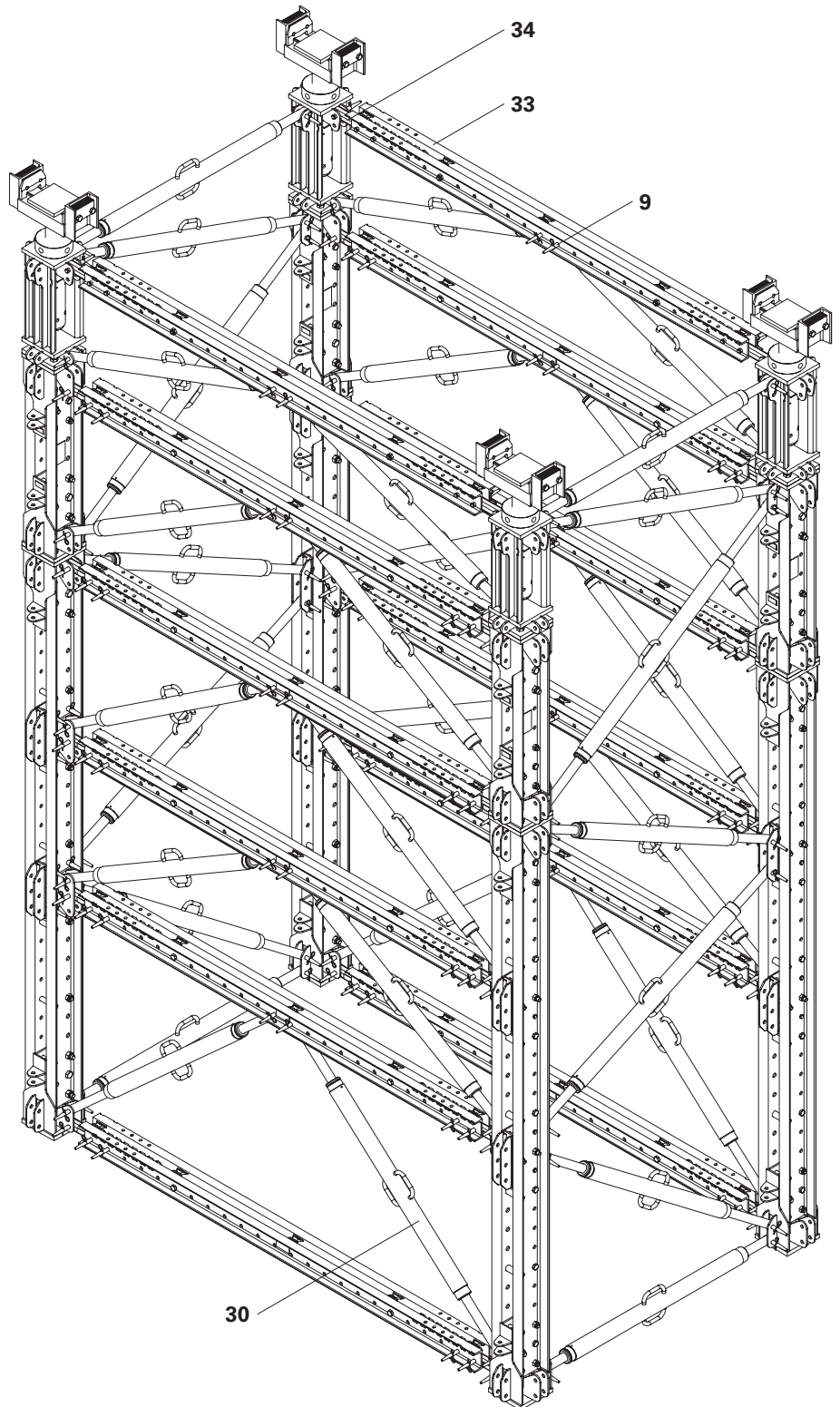

Fig. A13.01

**Tower configuration**  
1.25-6.5 x 1.25-6.5 m

Pos. Name

9	Fitting pin $\varnothing$ 21 x 120
10	Cotter pin 4/1, galv.
30	SLS heavy-duty spindle
33	Steel waler universal SRU U120
34	Adapter VST-SRU



Connecting means for heavy-duty spindles SLS and steel waler universal SRU U120 must be ordered separately.

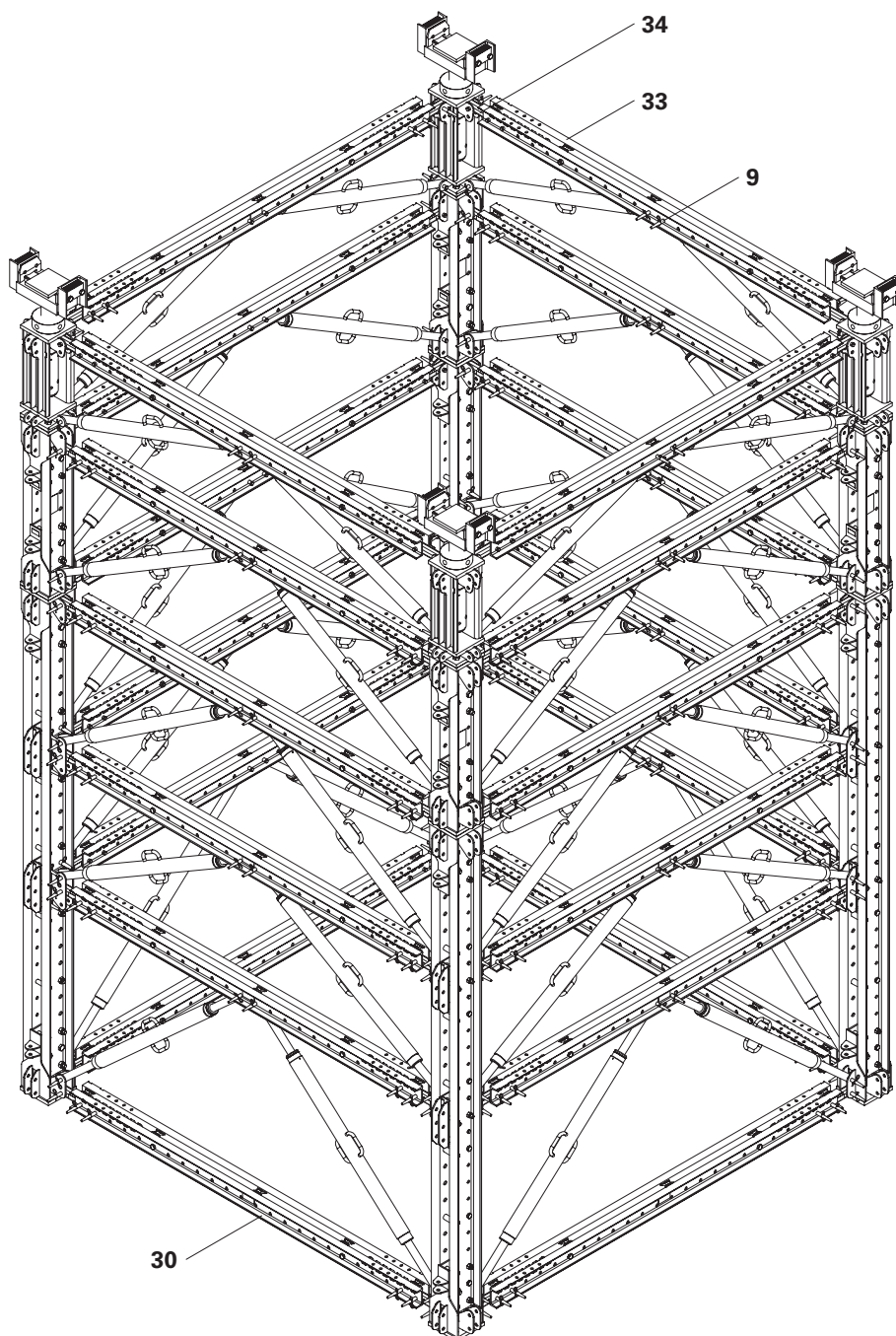

Fig. A14.01

# A15 Height compensation arrangement



When arranging the height adjusts VST 25 and VST 12.5, the following must be observed:

- A maximum of one height adjust VST 12.5 (**44**) and one height adjust VST 25 (**45**) may be placed under the head spindle (**28**).
- Additional height adjusts VST 12.5 (**44**) and height adjusts VST 25 (**45**) must be arranged individually between the modules positioned below.

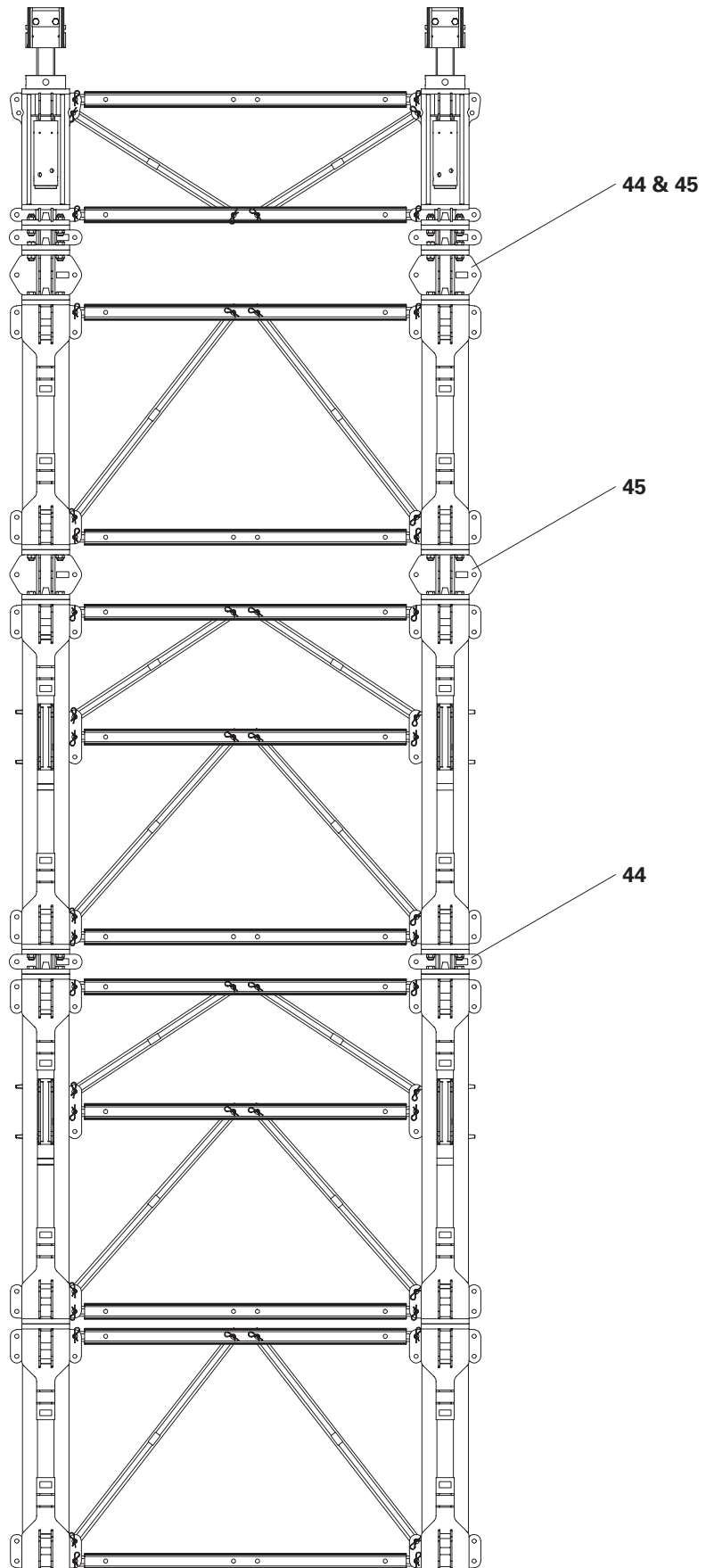

Fig. A15.01

# A16 Assembly of two cross connectors VST on the RCS / bracing connector VST

## Components

Pos. Name

<b>2 - 7</b>	Climbing rail RCS 148 – 998
<b>8</b>	Bracing connector VST
<b>13</b>	Cross connector VST
<b>15</b>	Nut ISO 7042 M20-8, galv.
<b>16</b>	Sleeve VST, galv.
<b>37</b>	Cyl. bolt ISO 4762 M20x150-8.8, galv.

## Installation

1. Insert sleeve VST, galv. (**16**) in the bracing connector VST (**8**).
2. Position 2x cross connector VST (**13**) on the climbing rail RCS 148 (**2**)\*.
3. Mount cross connectors VST (**13**) to the climbing rail RCS 148 (**2**)\* by means of cyl. bolt ISO 4762 (**37**) and nut ISO 7042 (**15**).

\* Depending on the module size, other climbing rails are used.



For assembly of the bracing connector (**8**), see Section B2, assembly of the VST leg.

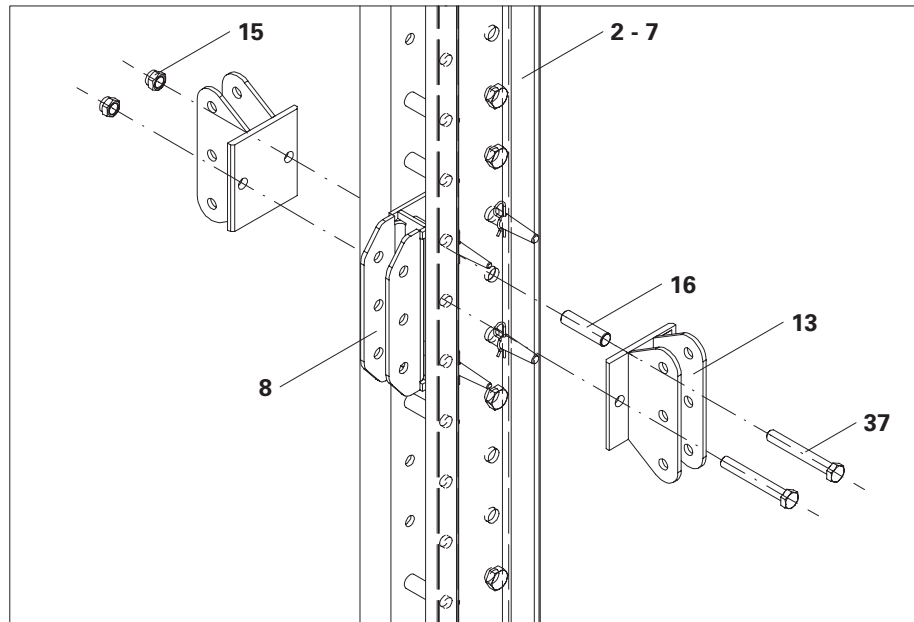

Fig. A16.01

## Components

Pos. Name

<b>8</b>	Bracing connector VST
<b>9</b>	Fitting pin $\varnothing$ 21 x 120
<b>10</b>	Cotter pin 4/1, galv.
<b>13</b>	Cross connector VST
<b>33</b>	Steel waler universal SRU U120
<b>34</b>	Adapter VST-SRU

## Installation

1. Mount adapter VST-SRU (**34**) on steel waler SRU U120 (**33**) using 2x fitting pins  $\varnothing$  21 x 120 (**9**) and secure with cotter pins 4/1, galv.
2. Mount Adapter VST-SRU (**34**) on the cross connector VST (**13**) in the centre using 1x fitting pin  $\varnothing$  21 x 120 (**9**) and secure with cotter pin 4/1, galv.

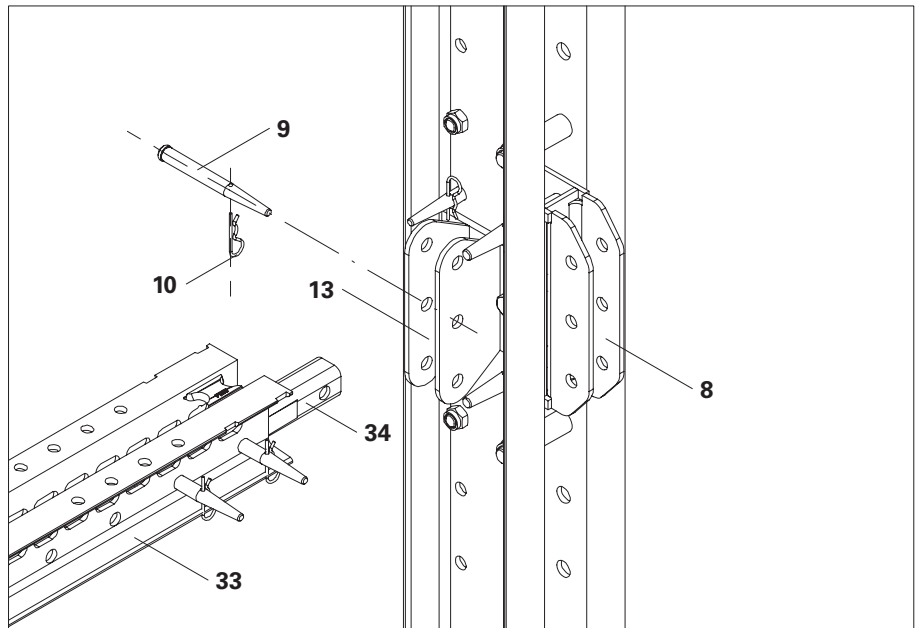

Fig. A17.01

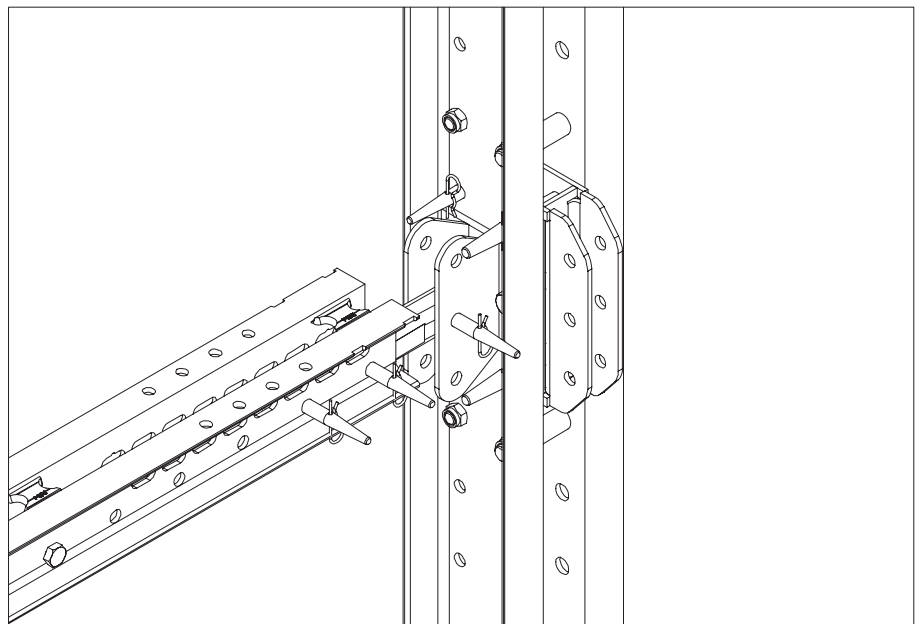

Fig. A17.02



## Warning

The system can only be declared as safe if project-specific planning is carried out. Otherwise, this can result in serious injuries.

⇒ Project-specific planning must be carried out for each working platform application.

## Components

Pos. Name

9	Fitting pin $\varnothing$ 21 x 120
10	Cotter pin 4/1, galv.
38	Connector UP / VST
39	Pin $\varnothing$ 20 x 140, galv. PERI UP Flex components

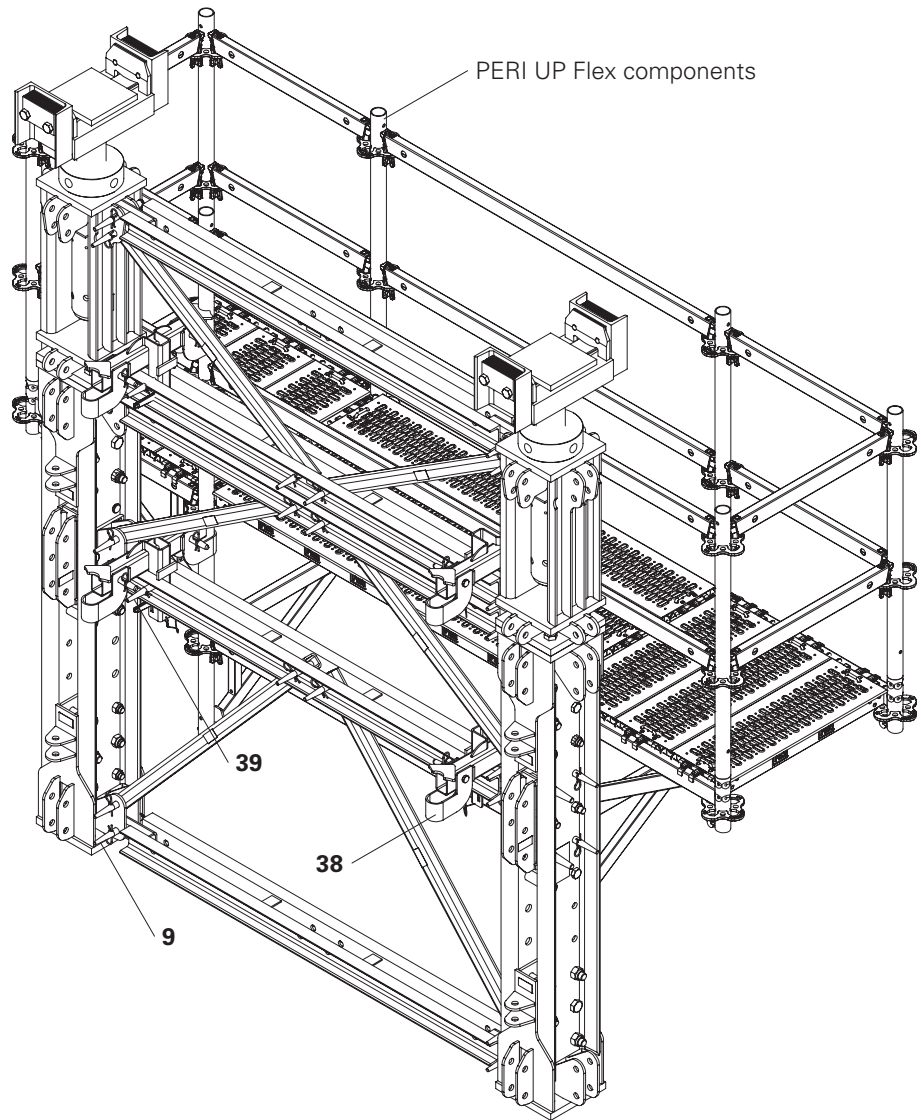

Fig. A18.01

## Connector UP-VST

Pos. Name

9	Fitting pin $\varnothing$ 21 x 120
10	Cotter pin 4/1, galv.
38	Connector UP-VST
38.1	Retaining lug
39	Pin $\varnothing$ 20 x 140, galv.
40	Wedge K, galv.

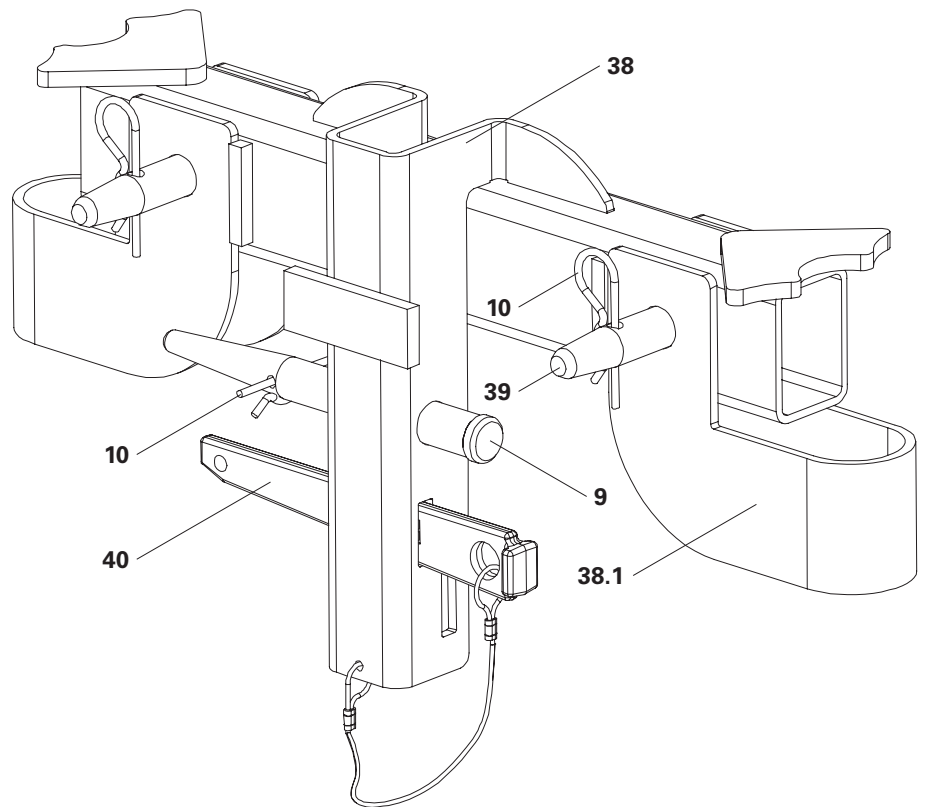

Fig. A18.02

## Components

Pos. Name

9	Fitting pin $\varnothing$ 21 x 120
10	Cotter pin 4/1, galv.
41	Leg connector VST 200/37.5
42	Horizontal connector VST 37.5

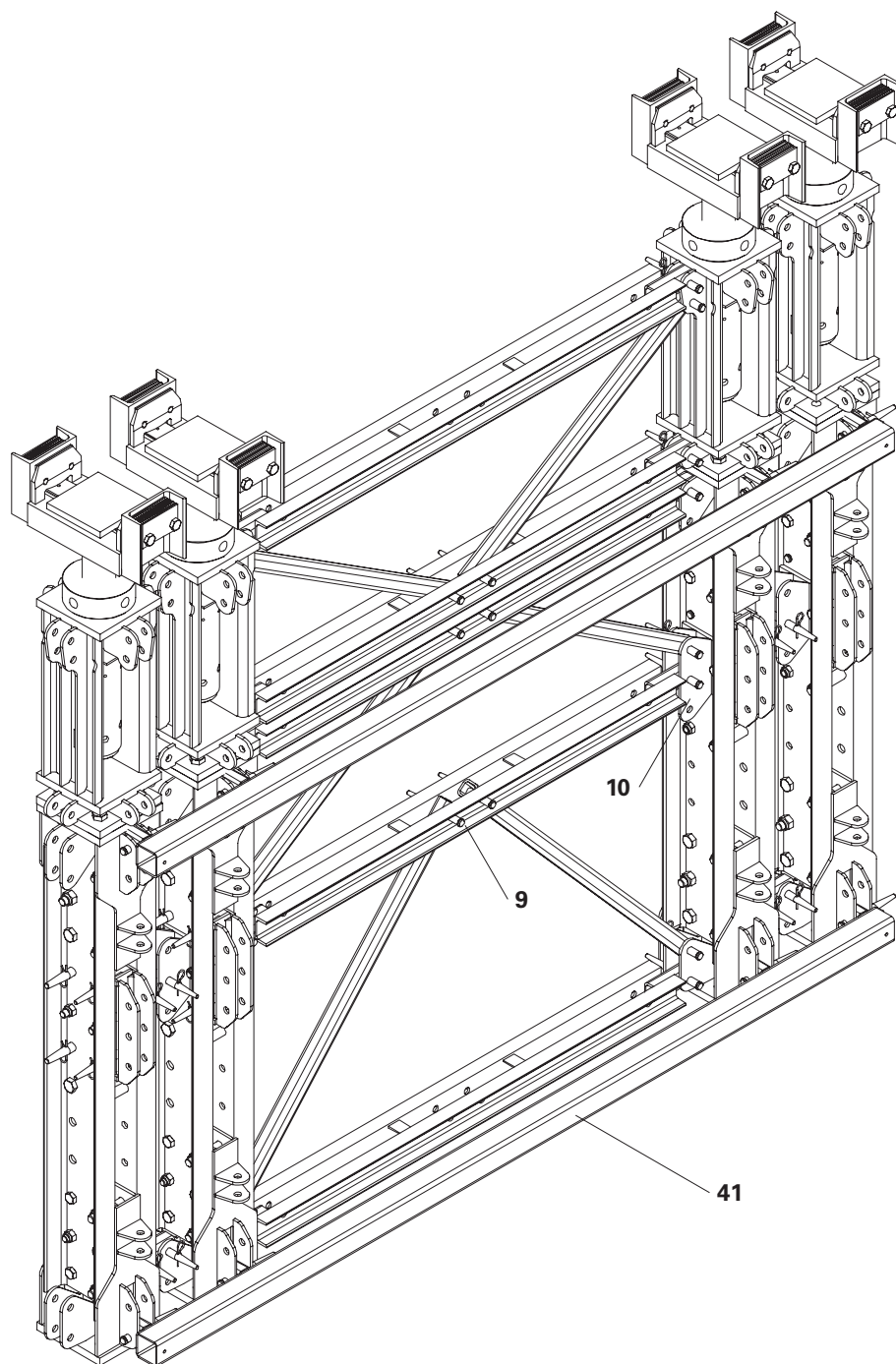

Fig. A19.01

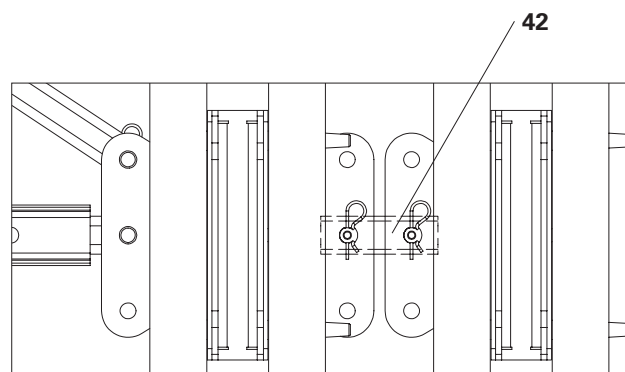

Fig. A19.01a





Observe the Instructions for Use for the hydraulic head spindle unit VST.



Fig. A20.02

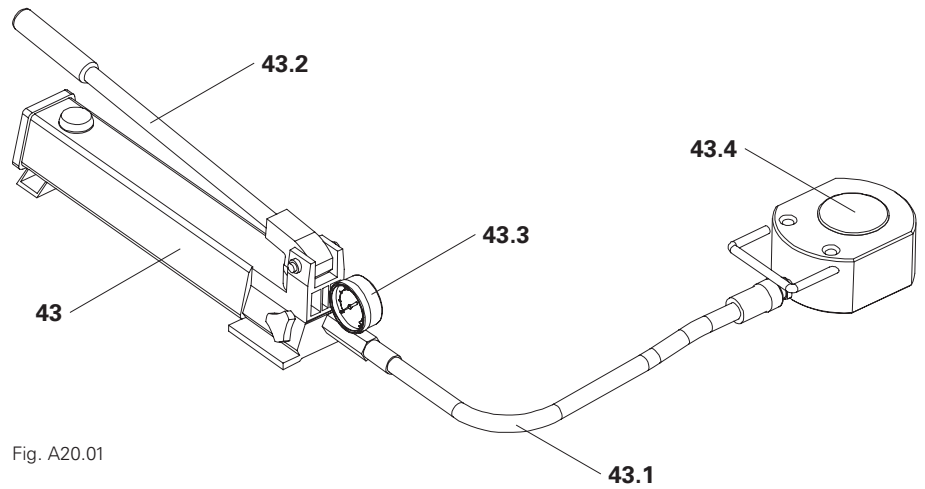

Fig. A20.01

## Components

Pos. Name

<b>43</b>	Hydraulic unit VST 75
<b>43.1</b>	Hydraulic hose
<b>43.2</b>	Hand pump
<b>43.3</b>	Pressure gauge
<b>43.4</b>	Hydraulic cylinder

## Operating state: assembly



### Warning

Parts that have been set aside can fall down.  
Falling parts can result in serious injury or even death.  
⇒ Do not use the assembly platforms as storage areas

- Rough preliminary adjustment.
- Assembly of the upper construction.
- Fine adjustment of the upper construction with the hydraulic head spindle device VST.

## Operating state: lowering and dismantling



### Warning

Parts that have been set aside can fall down, particularly during lowering operations.  
Falling parts can result in serious injury or even death.  
⇒ Do not use the assembly platforms as storage areas

- After the upper construction has reached the required load-bearing capacity, the VST Heavy-Duty Shoring Tower is then lowered according to specifications laid down by the responsible structural engineer.
- Dismantling of additional load-bearing elements according to project-specific planning.



A project-specific lifting and lowering plan, as well as detailed static verification is always required.

Lifting or lowering operations only take place if a competent person has given the go-ahead and the upper construction has sufficient load-bearing capacity.

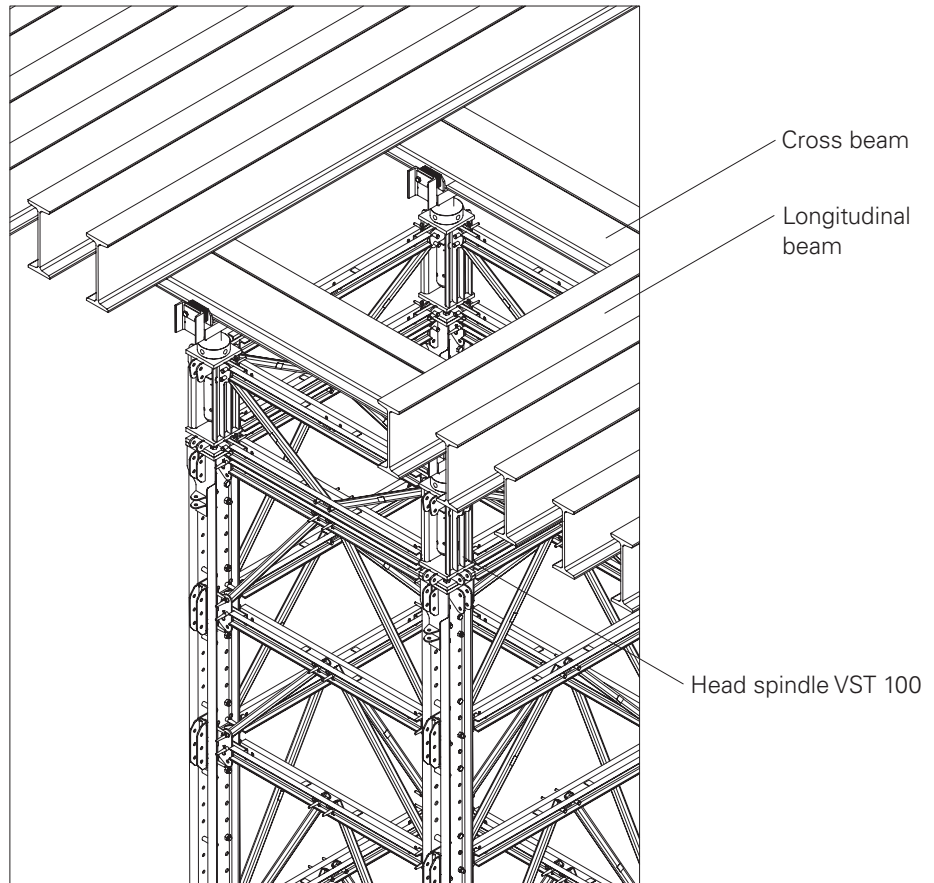

Fig. B1.01

## Preparation of the RCS rail

1. Support the RCS rails with square timbers or the like ( $h \geq 10$  cm) on a flat surface.
2. Remove the first pair of bolts (M20 and M24) from the climbing rail.
3. Remove external spacers.(Fig. B2.01a)



- Check the assembly position of the prop base VST 48.
- After the bolts have been removed, five rows of holes must then be free up to the next pair of bolts. (Fig. B2.01a)

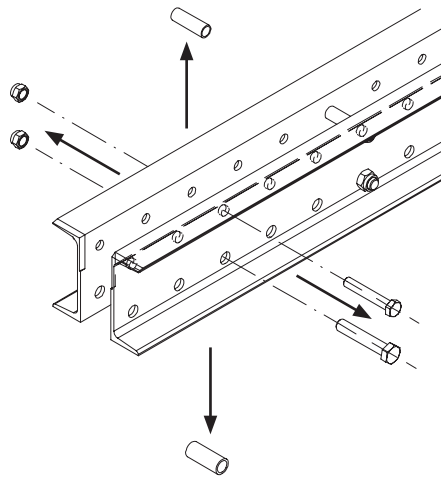

Fig. B2.01a

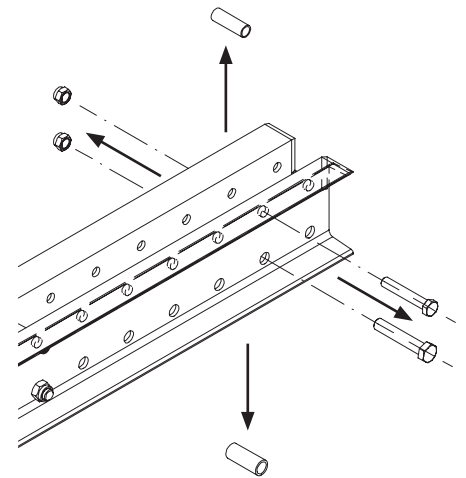

Fig. B2.01b

4. Remove the final pair of bolts (M20 and M24) from the climbing rail.
5. Remove external spacers.(Fig. B2.01b)



- Check the assembly position of the prop connector VST 48.
- After the bolts have been removed, six rows of holes must then be free up to the next pair of bolts.(Fig. B2.01b)

## Preparation of the prop base VST 48

1. Remove all 6 bolt connections from the prop base VST 48 (**17**). (Fig. B2.02)

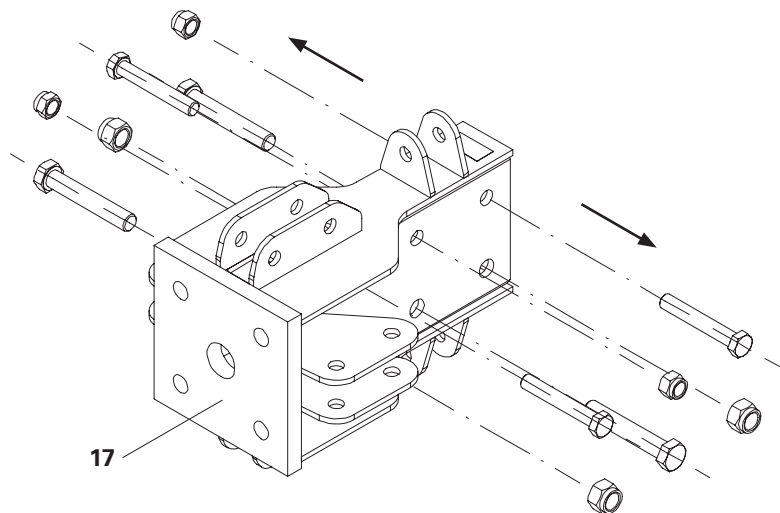

Fig. B2.02

## Preparation of the prop connector VST 48

1. Remove all 6 bolt connections from the prop connector VST 48 (**21**). (Fig. B2.03)

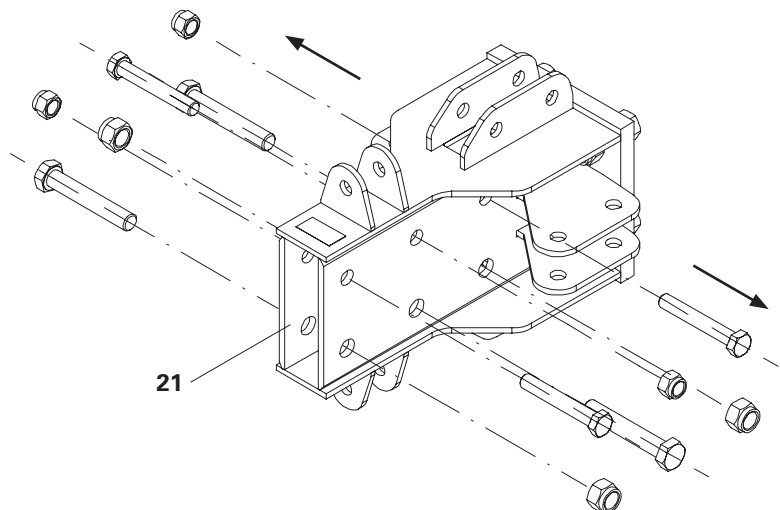

Fig. B2.03

## Prop connector VST 48



### Caution

Moving components!  
There is a risk of hands being crushed during insertion.  
⇒ Wear suitable safety gloves.



Pay close attention to the assembly position.  
(Six rows of holes free)

### Bolting the prop connector VST 48 to the climbing rail RCS

1. Insert prop connector VST 48 (21) into the climbing rail RCS (3)\* on the side with the 6 free rows of holes.
2. Insert 1 x bolt ISO 4014 M20 (18) from the left-hand side.
3. Insert 2 x bolts ISO 4014 M20 (18) from the right-hand side.
4. Attach nuts ISO 7042 M20 (15) and tighten the connections.
5. Insert 1 x bolt ISO 4014 M24 (19) from the right-hand side.
6. Insert 2 x bolts ISO 4014 M24 (19) from the left-hand side.
7. Attach nuts ISO 7042 M24 (20) and tighten the connections.

\* Depending on the module size, other climbing rails RCS must be used.

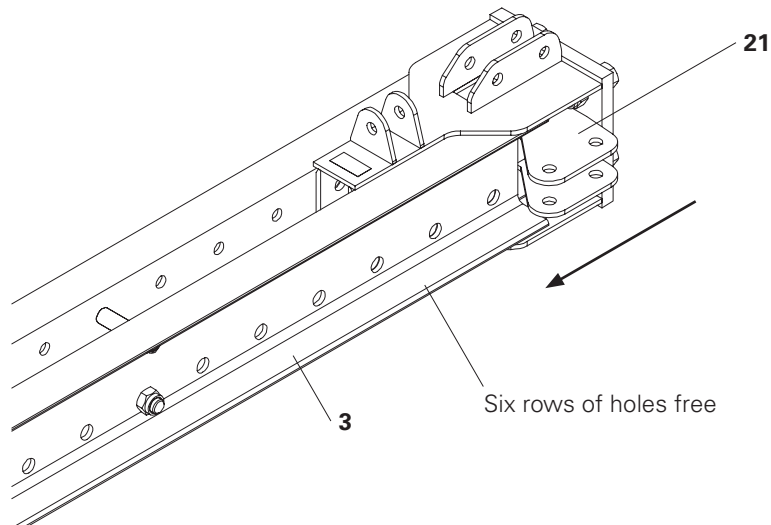

Fig. B2.04a

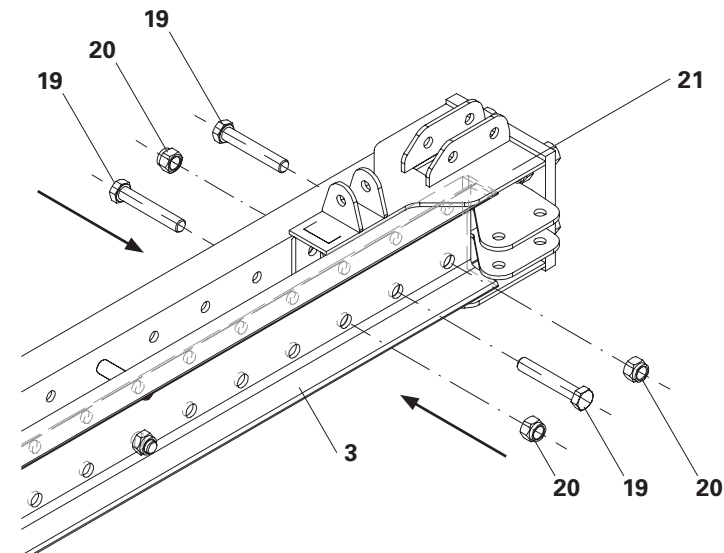

Fig. B2.04b

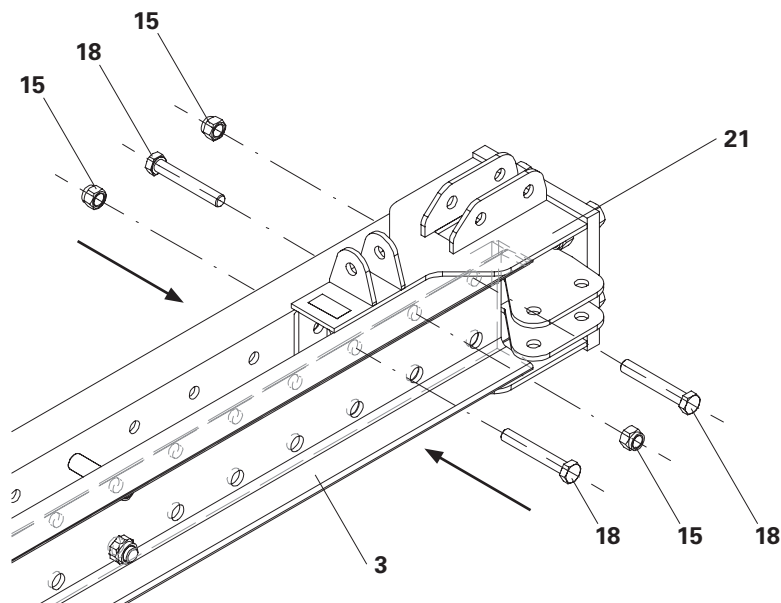

Fig. B2.04c

## Prop base VST 48



### Caution

Moving components!  
There is a risk of hands being crushed during insertion.  
⇒ Wear suitable safety gloves.



Pay close attention to the assembly position.  
(Six rows of holes free)

### Bolting the prop base VST 48 to the climbing rail RCS

1. Insert prop base VST 48 (17) into the climbing rail RCS 248 (3)\* on the side with the 5 free rows of holes.
2. Insert 1 x bolt ISO 4014 M20 (18) from the left-hand side.
3. Insert 2 x bolts ISO 4014 M20 (18) from the right-hand side.
4. Attach nuts ISO 7042 M20 (15) and tighten the connections.(Fig. B2.05b)
5. Insert 1 x bolt ISO 4014 M24 (19) from the right-hand side.
6. Insert 2 x bolts ISO 4014 M24 (19) from the left-hand side.
7. Attach nuts ISO 7042 M24 (20) and tighten the connections.(Fig. B2.05c)

\* Depending on the module size, other climbing rails RCS must be used.

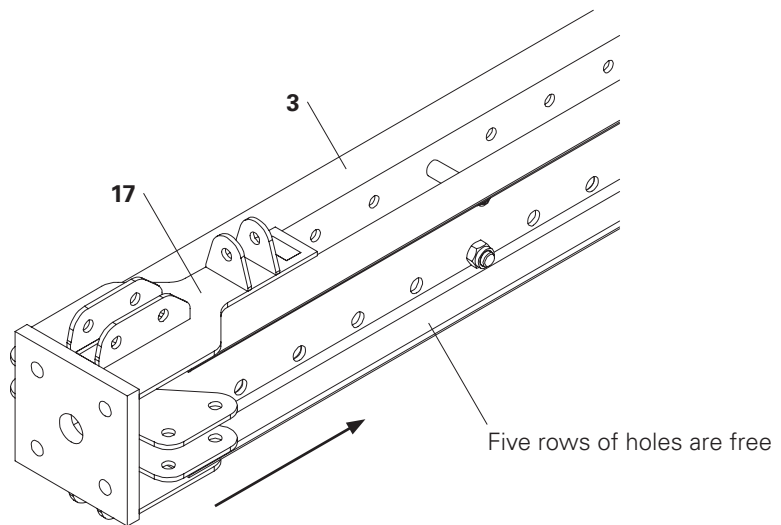

Fig. B2.05a

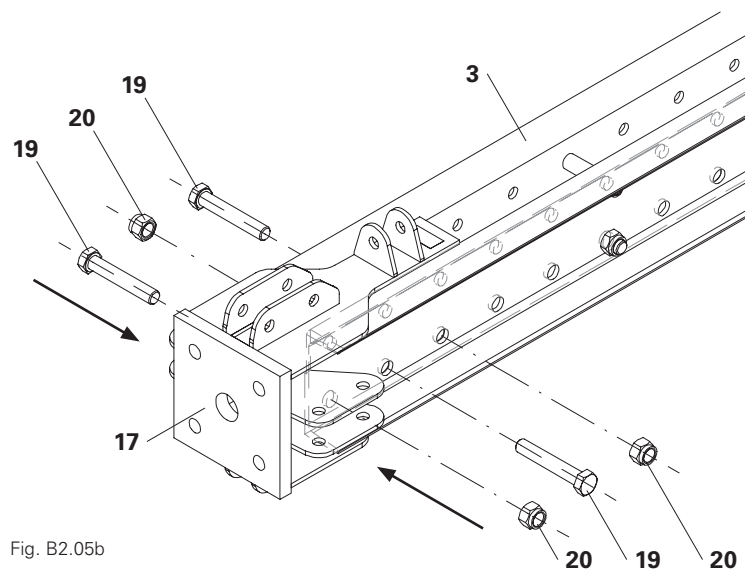

Fig. B2.05b

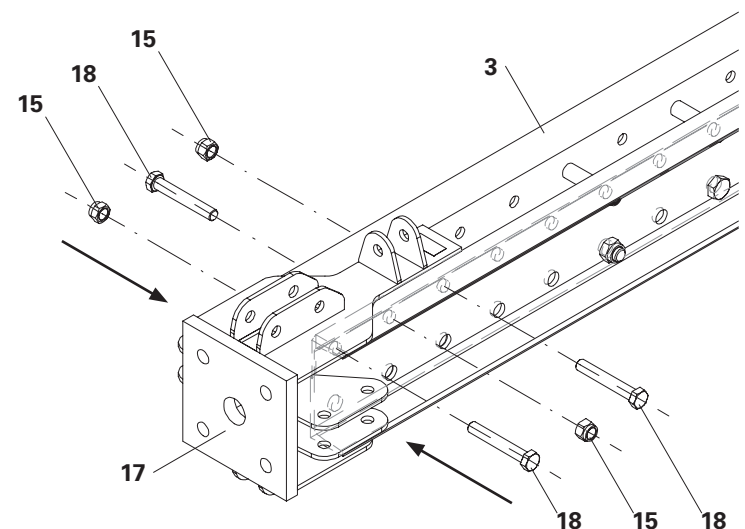

Fig. B2.05c

## Bracing connector VST



### Caution

Moving components!  
There is a risk of hands being crushed during insertion.  
⇒ Wear suitable safety gloves.



- The bracing connector VST (8) must be connected at the height of the horizontal ledger VST (23).
- The positions are indicated through the distances in Section A1 module overview.

### Mounting the bracing connector VST (8) on the climbing rail RCS

1. Insert the bracing connector VST (8) into the climbing rail RCS.
2. Centre the bracing connector VST (8) with sleeve VST (16).
3. Connect the bracing connector VST (8) with 2x fitting pins Ø 21 mm (9) and 2x fitting pins Ø 26 mm (11) respectively.
4. Secure fitting pins Ø 21 mm (9) with cotter pins 4/1, galv. and fitting pins Ø 26 mm (11) with cotter pins 5/1, galv.

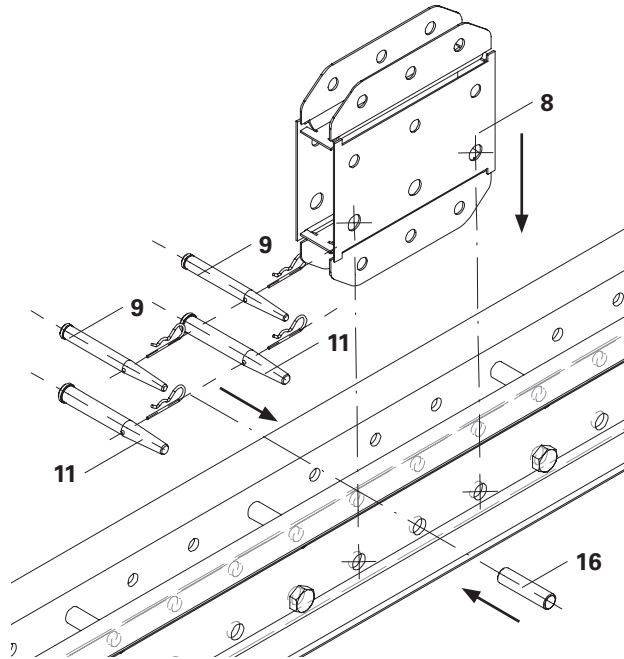

Fig. B2.06a

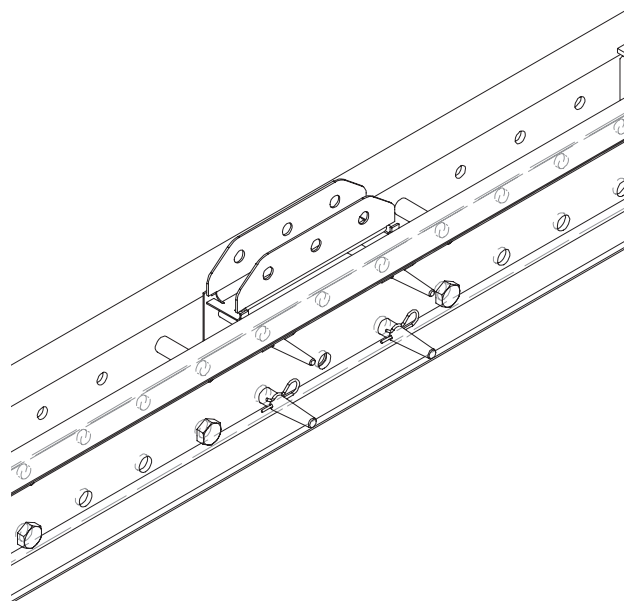

Fig. B2.06b

## Cross connector VST

### Mounting of the cross connector VST (13) on the climbing rail RCS

1. Position the cross connector VST (13) on the axis of the bracing connector VST (8).
2. Insert 2 x Bolts ISO 4014 M24 (19).
3. Attach nuts ISO 7042 M24 (20) and tighten the connections.

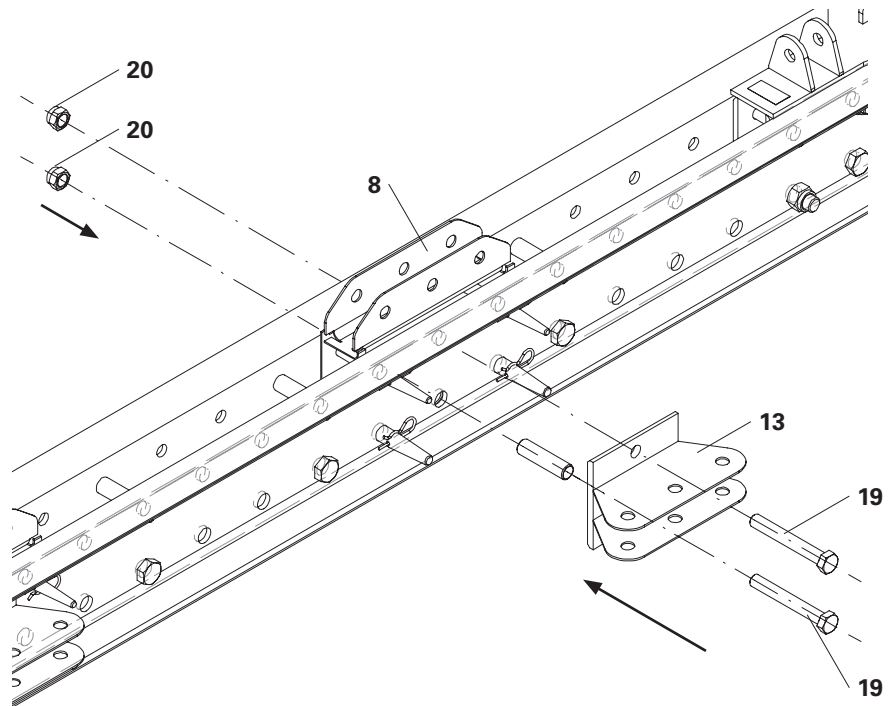

Fig. B2.07a

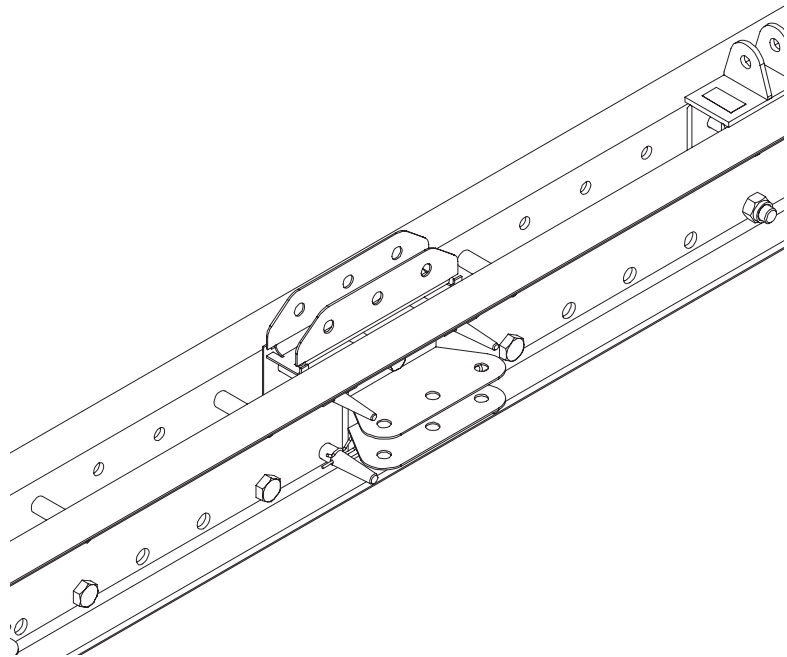

Fig. B2.07b

## Horizontal ledger VST 200



- Always bolt the horizontal ledger VST onto the cross connector VST.
- Bracing above the bracing connector VST is not permitted.
- Position VST legs at a distance of 2.0 m to each other on a flat assembly surface.
- Firstly, the horizontal ledgers VST 200 (23) are mounted on the prop connector VST (21) and the prop base VST (17). This results in the planned spacing for the legs.
- The two outer holes are used for the prop connector VST (21) and prop base VST (17) respectively.
- The centre holes are used for the cross connector VST (13).

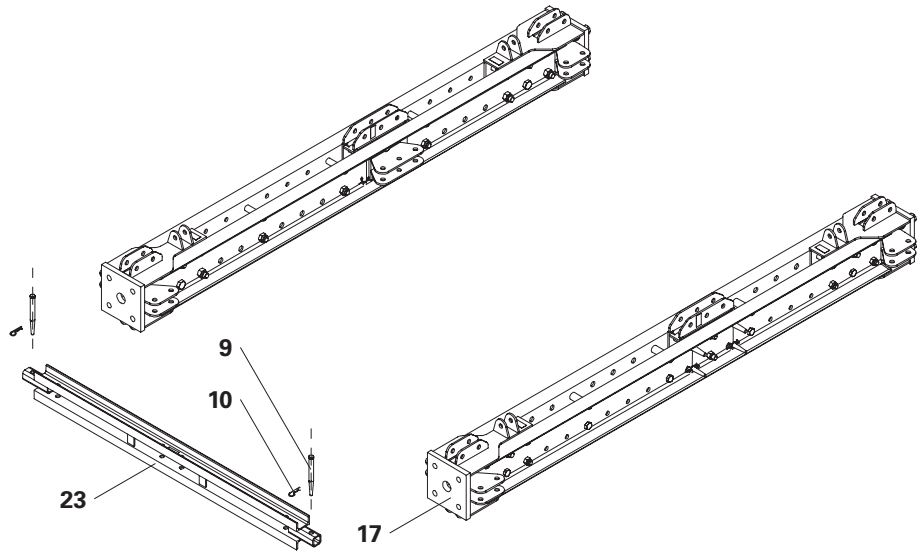

Fig. B3.01a

### Mounting the horizontal ledger VST 200 on the VST legs

1. Insert the horizontal ledger VST 200 (23) into the prop base VST (17).
2. Connect the horizontal ledger VST 200 (23) with 1x fitting pin  $\varnothing$  21 mm (9) on both sides respectively.
3. Secure fitting pins with cotter pins 4/1 (10). (Fig. B3.01a)
4. Repeat the procedure for all horizontal ledgers VST 200 (23). (Fig. B3.01b)

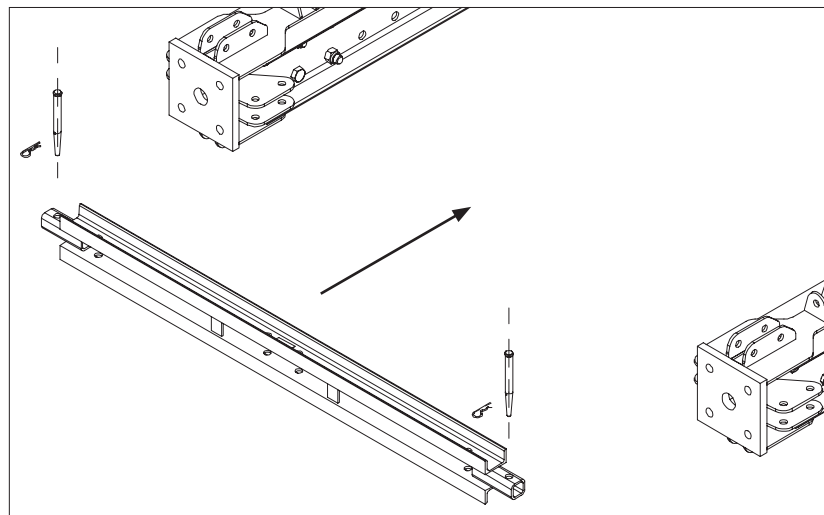

Fig. B3.01b

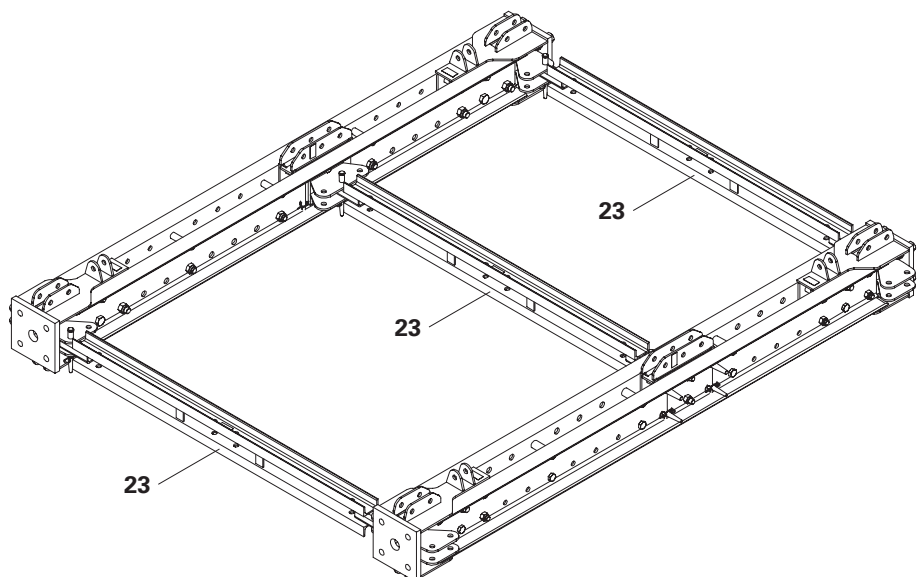

Fig. B3.01c



## Diagonal strut VST



- In order to erect the module at right angles, diagonal struts VST must be mounted.
- The appropriate diagonal struts VST can be found in Section A1 module overview.
- All diagonal struts can be installed in the same way.

### Mounting the diagonal struts VST on the module

1. Connect the diagonal strut VST 200/150 (**24a**)\* to the prop base VST 48 (**17**) using 1x fitting pin  $\varnothing$  21 mm (**9**).
2. Swivel the diagonal strut VST 200/150 (**24a**)\* as far as possible into the horizontal ledger VST 200 (**23**). (Fig. B3.02a)
3. Connect the second diagonal strut VST 200/150 (**24b**)\* to the other prop base VST 48 (**17**) using 1x fitting pin  $\varnothing$  21 mm (**9**).
4. Swivel second diagonal strut VST 200/150 (**24b**)\* into the horizontal ledger VST 200 (**23**). (Fig. B3.02b)
5. Secure both diagonal struts VST 200/150 (**24**)\* to the horizontal ledgers VST 200 (**23**) using 1x fitting pin  $\varnothing$  21 mm (**9**) respectively. (Fig. B3.02c)
6. Repeat the procedure for all diagonal struts VST. (Fig. B3.02d)

\* Depending on the module size, other diagonal struts VST are to be used.



The module is now fully assembled and can be erected or assembled to form a complete tower.



Do not connect the horizontal support to the bracing connector VST, connect it to the cross connector VST instead. (Fig. B3.02d) (Fig. B3.02e)

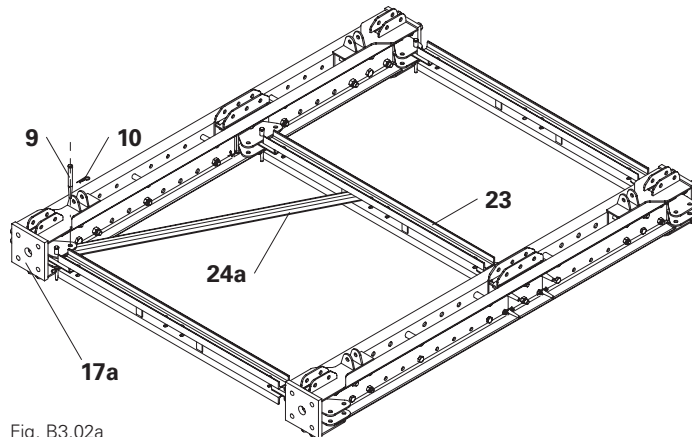

Fig. B3.02a

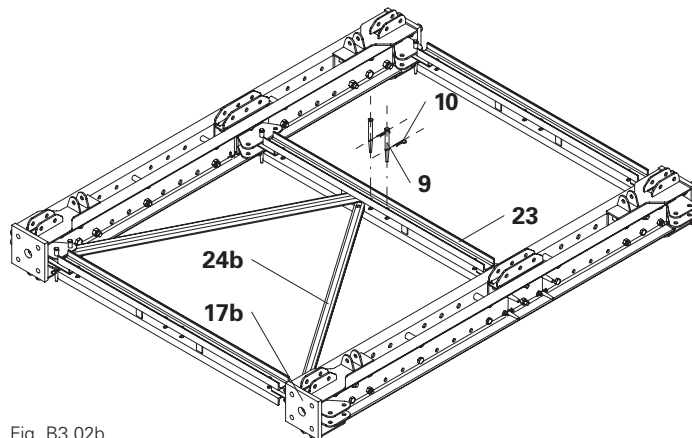

Fig. B3.02b

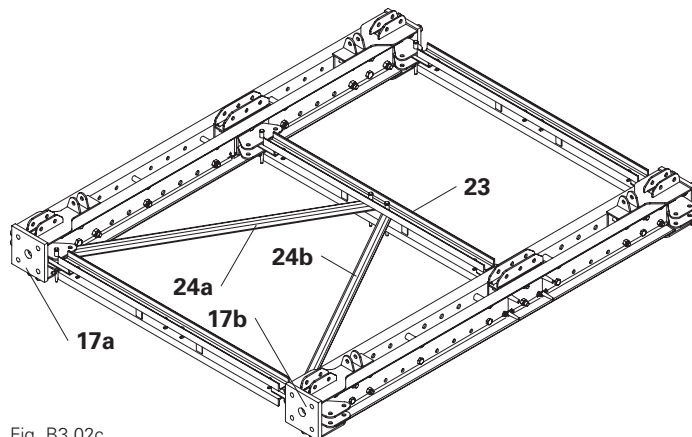

Fig. B3.02c

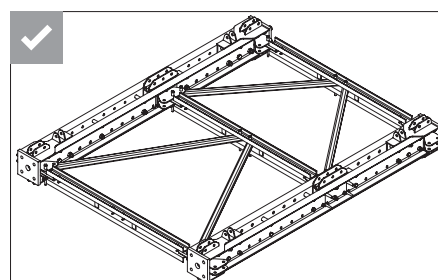

Fig. B3.02d

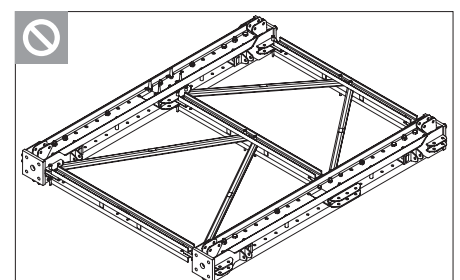

Fig. B3.02e

## Assembling the head spindle frame

### Frame assembly

1. Place head spindles VST 100 (**28**) on square timbers.
2. Connect the bottom horizontal ledger VST 200 (**23a**) to the first head spindle VST 100 (**28a**) using 1x fitting pin  $\varnothing$  21 mm (**9**) and secure with cotter pin 4/1, galv.
3. Connect the bottom horizontal ledger VST 200 (**23a**) to the second head spindle VST 100 (**28b**) using 1x fitting pin  $\varnothing$  21 mm (**9**) and secure with cotter pin 4/1, galv.(Fig. B4.01a)
4. Connect the upper horizontal ledger VST 200 (**23b**) to the first head spindle VST 100 (**28a**) using 1x fitting pin  $\varnothing$  21 mm (**9**) and secure with cotter pin 4/1, galv.
5. Connect the upper horizontal ledger VST 200 (**23b**) to the second head spindle VST 100 (**28b**) using 1x fitting pin  $\varnothing$  21 mm (**9**) and secure with cotter pin 4/1, galv.(Fig. B4.01b)

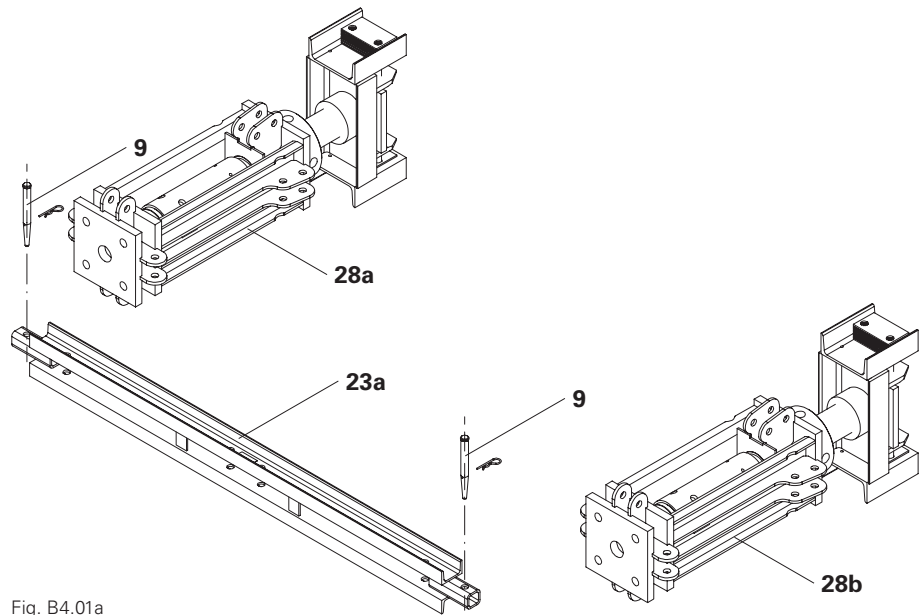

Fig. B4.01a

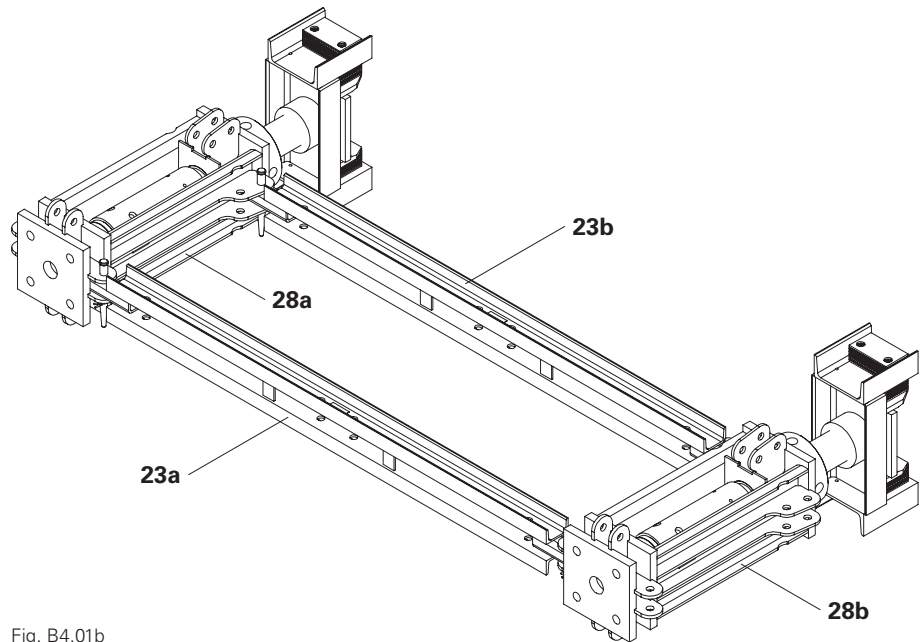

Fig. B4.01b

6. Connect the first diagonal strut VST 200/62.5 (**27a**) to the head spindle VST 100 (**28a**) using 1x fitting pin  $\varnothing$  21 mm (**9**) and secure with cotter pin 4/1, galv.
7. Connect the first diagonal strut VST 200/62.5 (**27a**) to the horizontal ledger VST (**23a**) using 1x fitting pin  $\varnothing$  21 mm (**9**) and secure with cotter pin 4/1, galv.
8. Connect the second diagonal strut VST 200/62.5 (**27b**) to the head spindle VST 100 (**28b**) using 1x fitting pin  $\varnothing$  21 mm (**9**) and secure with cotter pin 4/1, galv.
9. Connect the second diagonal strut VST 200/62.5 (**27b**) to the horizontal ledger VST (**23a**) using 1x fitting pin  $\varnothing$  21 mm (**9**) and secure with cotter pin 4/1, galv. (Fig. B4.01c)

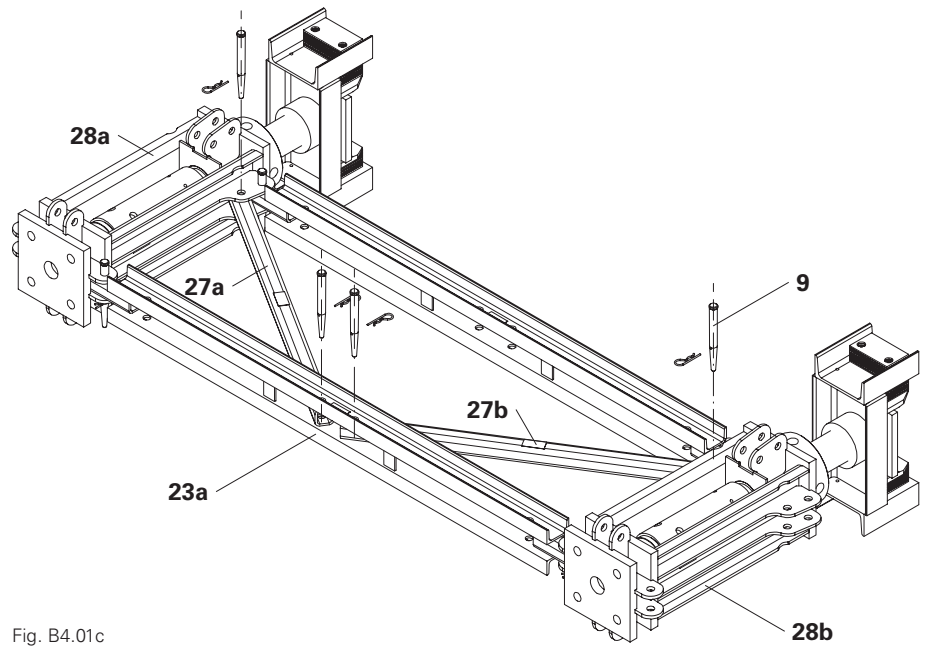

Fig. B4.01c

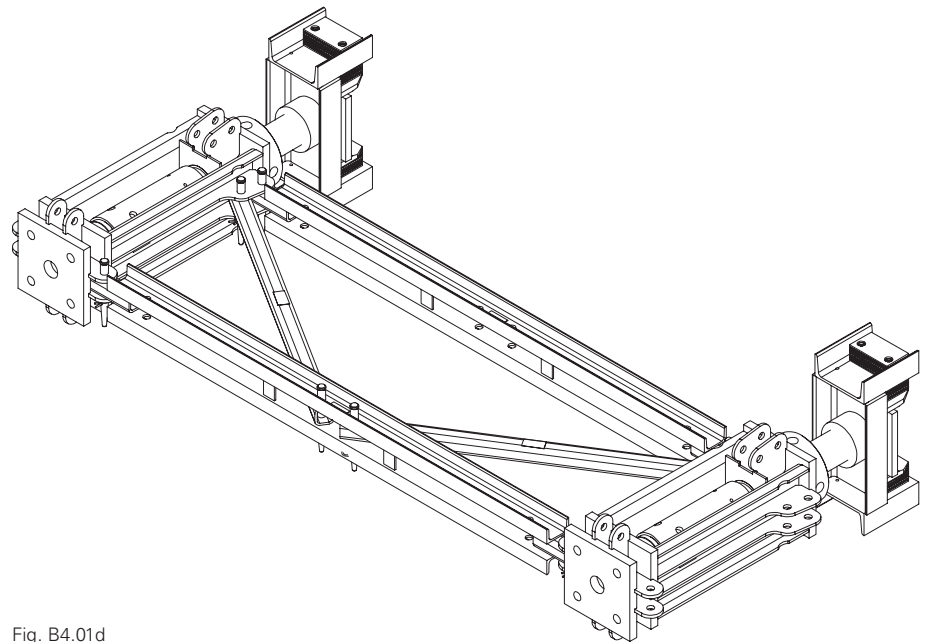

Fig. B4.01d

## Adjusting the spacer plates of the head spindle VST 100



- The head spindle VST 100 (28) is adjustable for cross beam widths from 20 cm to 32 cm.
- For the centric position of the cross-beam, the spacer plates are uniformly positioned on the two inner sides of the U-head.
- Observe the Instructions for Use for the hydraulic head spindle unit VST.

### Adjusting the spacer plates

1. Loosen the four bolts of the U-head (28.1) by turning them counter-clockwise, and then remove.
  2. Remove spacer plates and adjust centring jaws by moving to width x of the cross beam.
  3. Fill the space between the centring jaws and U-head with the same number of spacer plates.
  4. Position remaining spacer plates (same number respectively) on the two outer sides of the U-head. Secure spacer plates using four bolts.
- The crossbeam can now be positioned centrally on the head spindle VST 100.

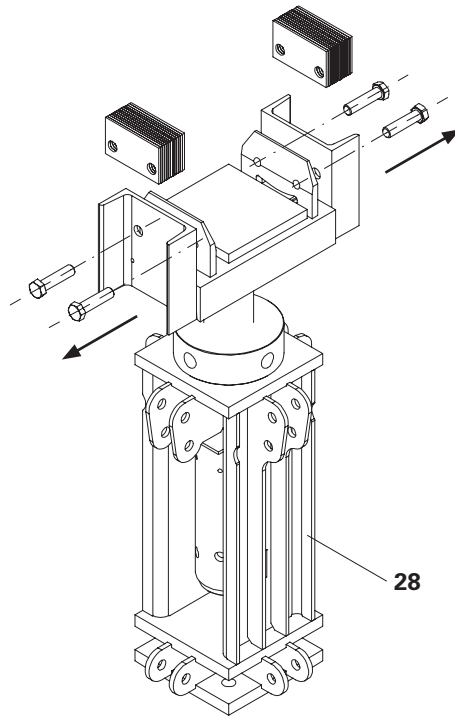

Fig. B4.02a

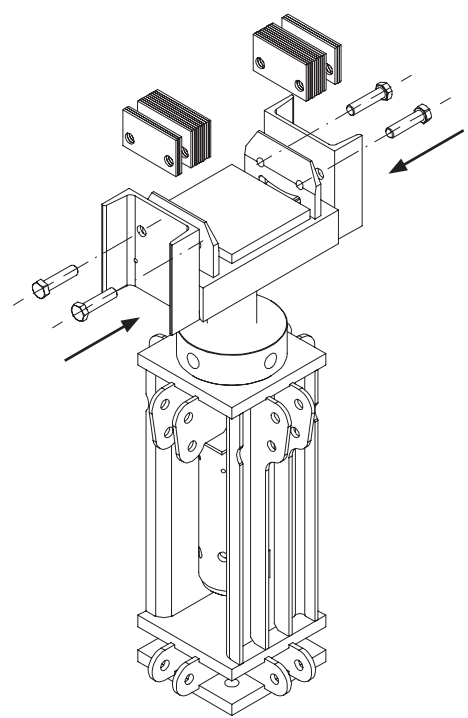

Fig. B4.02b

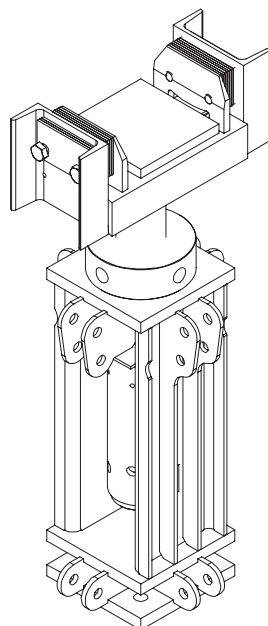

Fig. B4.02c

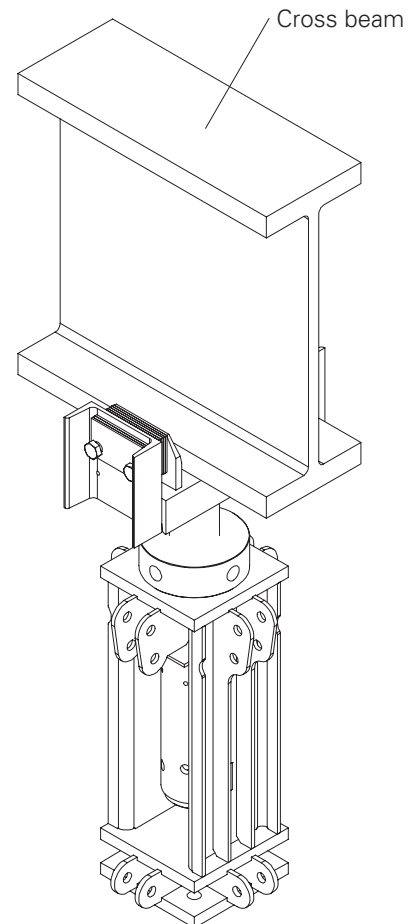

Fig. B4.02d

## Tower assembly with VST components



### Danger

Heavy, suspended load!

The heavy load can fall down and result in serious, irreversible injury or even death.

- ⇒ Standing under a suspended load is prohibited.
- ⇒ Temporary situations, e.g. with square timbers, must be secured.



- For modules with a length of 5 m and more, a third horizontal ledger VST 200 (23) must be installed in order to prevent any deflection.
- For load-bearing capacities, see Section F2 Load-bearing capacities.

### Preparation of the assembly

1. Attach the crane to the spacers.
2. On each side, connect 1x horizontal ledger VST 200 (23) to the prop bases VST 48 (17) and prop connectors VST 48 (21) by means of 1x fitting pin Ø 21 mm (9) respectively.(Fig. B5.01)

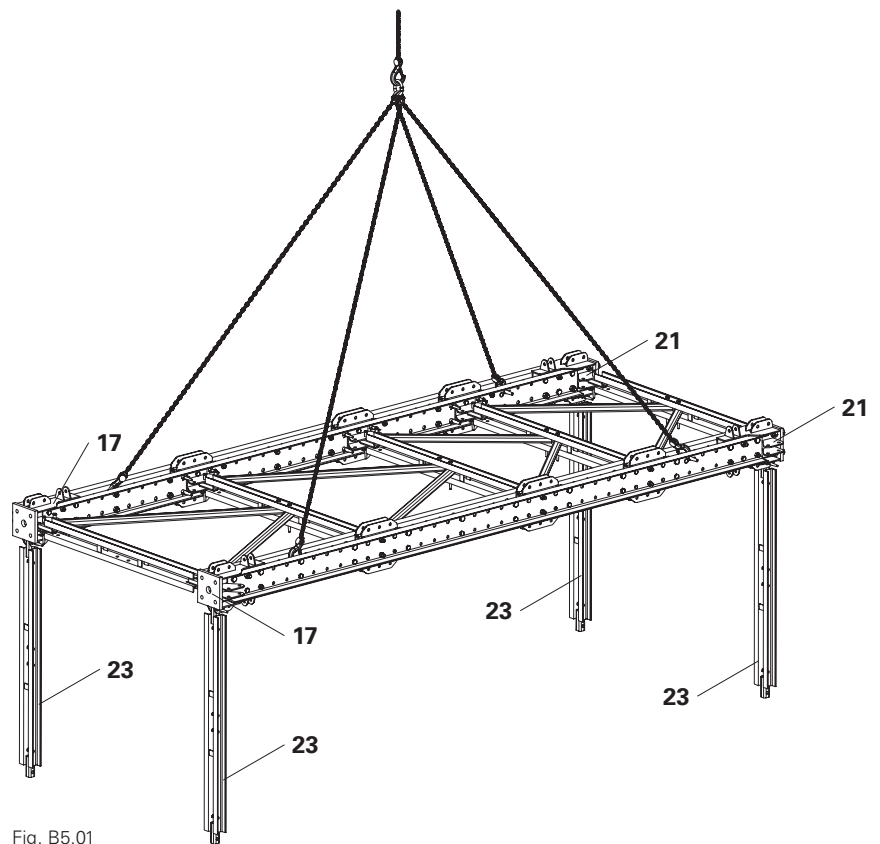
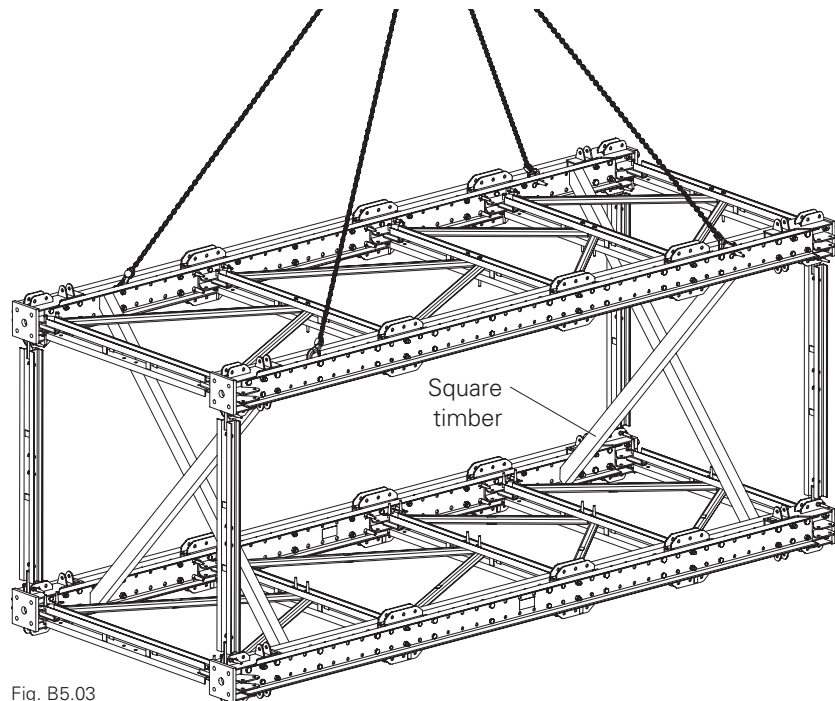
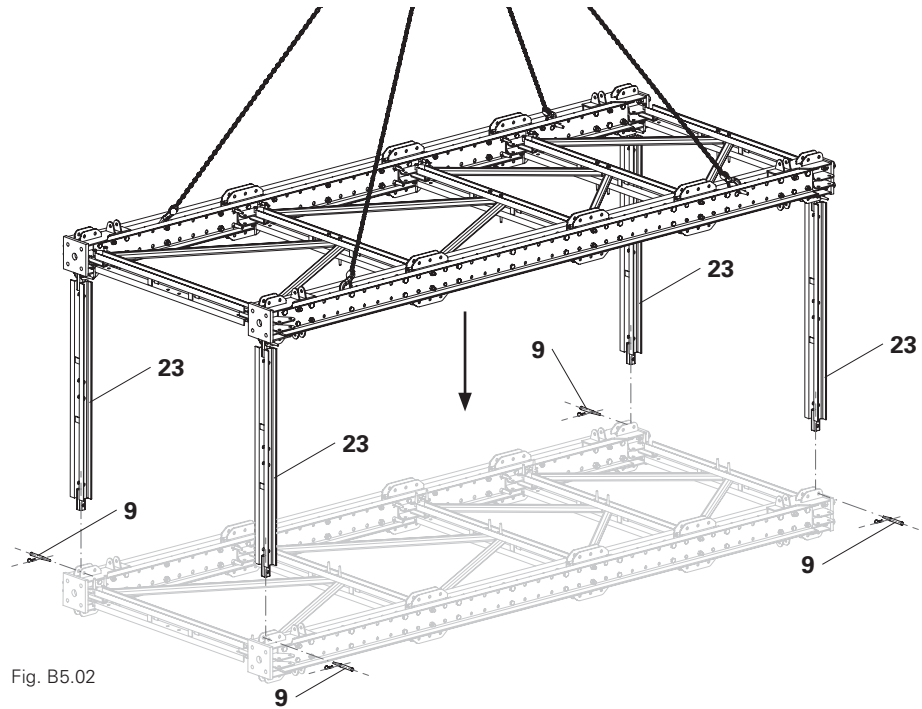

Fig. B5.01

## Installation

1. Move the suspended module with the same alignment over the second module.
2. Lower the module with the crane until the bottom fitting pins  $\text{Ø } 21 \text{ mm}$  (**9**) can be mounted. (Fig. B5.02)
3. Connect the horizontal ledger VST 200 (**23**) to the bottom module using 1x fitting pin  $\text{Ø } 21 \text{ mm}$  (**9**) each.
4. Secure position, e.g. with square timbers. (Fig. B5.03)





## Warning

Unsecured or unsupported component during assembly!  
An unsecured, unsupported component can topple over or collapse and result in serious injuries.

⇒ At least one diagonal strut VST (26) must always be installed per side before the crane lifting gear is removed.

### Assembly of the diagonal strut VST

1. On each side, insert 1x diagonal strut VST (26)\* into the horizontal ledger VST 200 (23).
2. Connect the diagonal struts VST (26) to the bracing connector VST (8) and horizontal ledger VST 200 (23) using 1x fitting pin  $\varnothing$  21 mm (9) each. (Fig. B5.04)
3. Remove crane lifting gear from the spacers.

\* Depending on the module size, other diagonal struts VST are to be used.

### Assembly of the horizontal ledger

1. Connect the second diagonal strut VST (26)\* to the bracing connector VST (8) and horizontal ledger VST 200 (23) using 1x fitting pin  $\varnothing$  21 mm (9) each.
2. Install the required horizontal ledgers VST 200 (23). (Fig. B5.05) (see Section B3, Module assembly)

\* Depending on the module size, other diagonal struts VST are to be used.

### Assembly of the diagonal struts

1. Install the required diagonal struts VST. (Fig. B5.06) (see Section B3, Module assembly)
2. Remove square timbers.

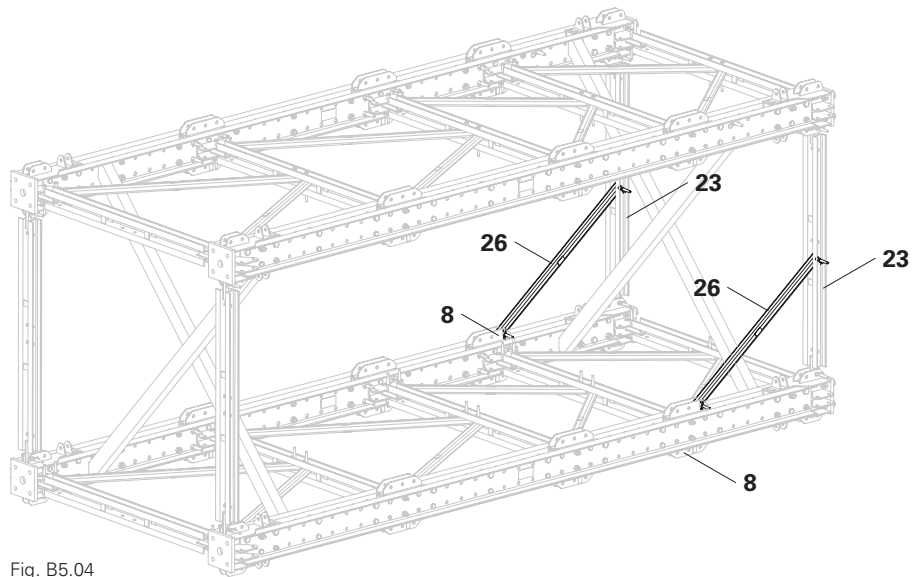

Fig. B5.04

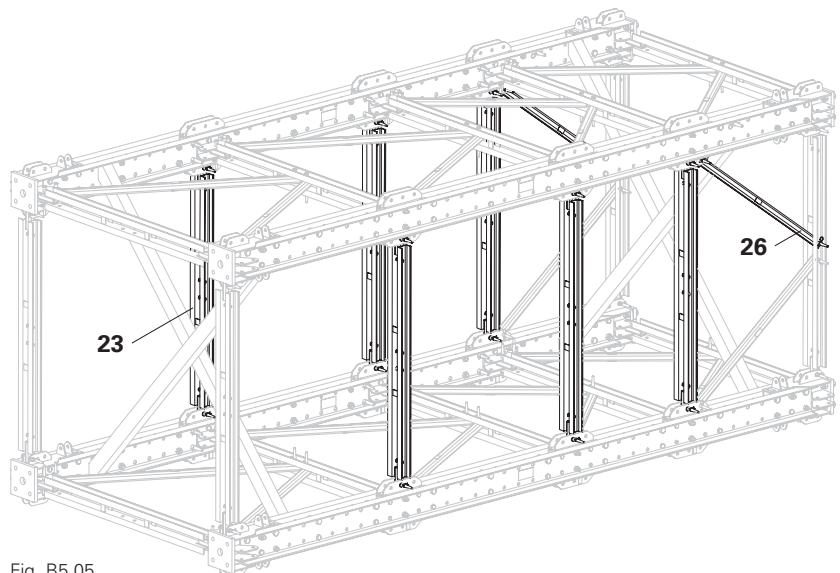

Fig. B5.05

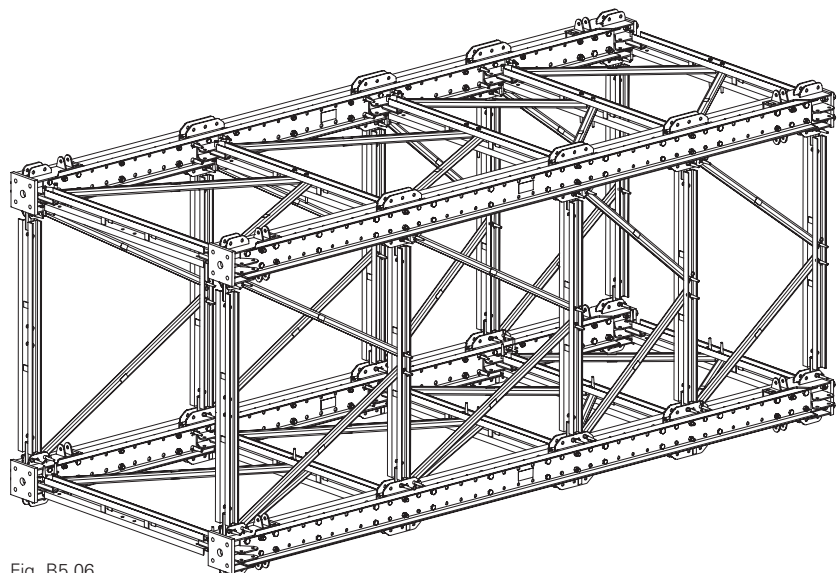

Fig. B5.06

## Tower assembly with SLS spindles



### Danger

Heavy, suspended load!  
The heavy load can fall down and result in serious, irreversible injury or even death.

- ⇒ Standing under a suspended load is prohibited.
- ⇒ Temporary situations, e.g. with square timbers, must be secured.



Adjust the required length on all four spindles according to the spacing of the legs.



- For modules with lengths of 5 m and more, a third heavy-duty spindle SLS (30) must be installed in order to prevent any deflection.
- For load-bearing capacities, see Section F2 Load-bearing capacities.

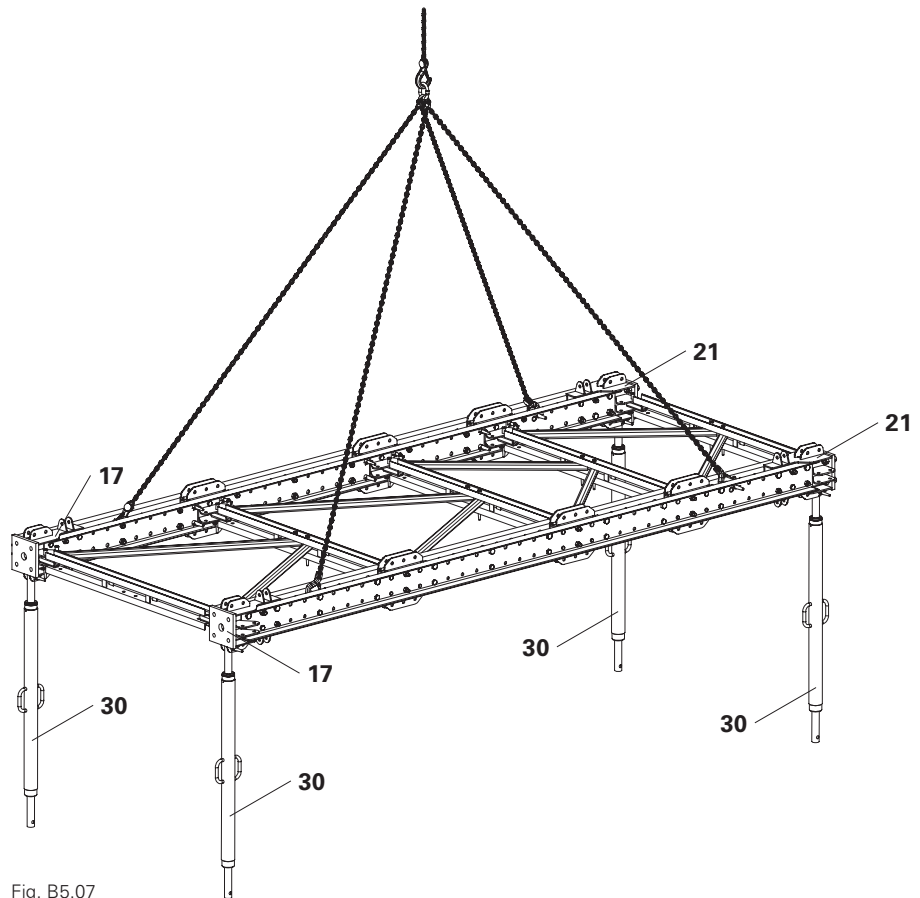

Fig. B5.07

### Preparation of the assembly

1. Attach the crane to the spacers.
2. Connect 2x heavy-duty spindles SLS (30) each to the prop bases VST 48 (17) and prop connectors VST 48 (21) by means of 1x fitting pin  $\varnothing$  21 mm (9) each.(Fig. B5.07)



## Installation

1. Move the suspended module with the same alignment over the second module.
2. Lower the module with the crane until the bottom fitting pins  $\text{Ø } 21 \text{ mm}$  (9) can be mounted. (Fig. B5.08)
3. Connect the heavy-duty spindles SLS (30) to the bottom module using 1x fitting pin  $\text{Ø } 21 \text{ mm}$  (9) each.
4. Secure position, e.g. with square timbers. (Fig. B5.09)

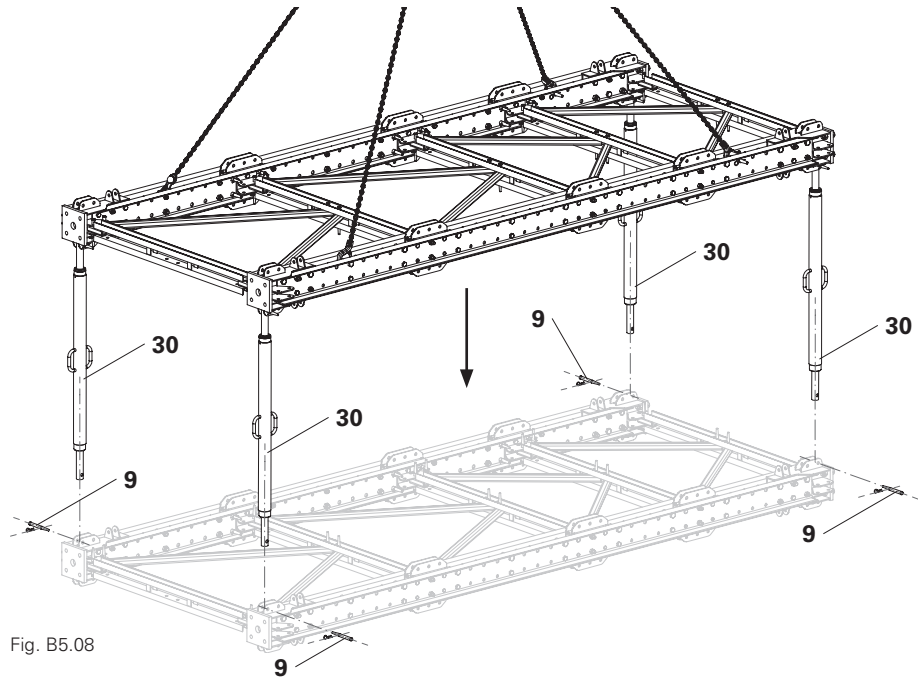

Fig. B5.08

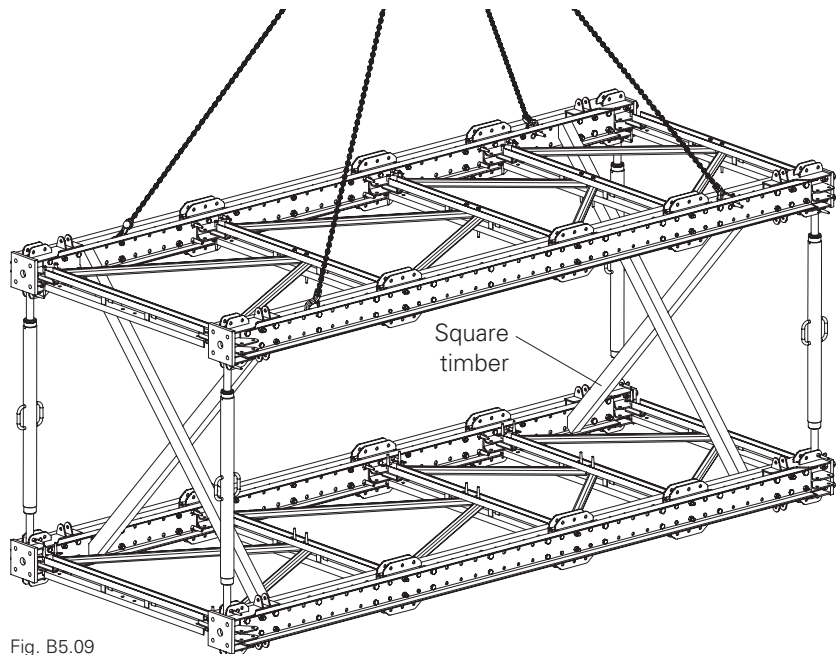

Fig. B5.09



## Warning

Unsecured or unsupported component during assembly!

An unsecured, unsupported component can topple over or collapse and result in serious injuries.

⇒ At least one heavy-duty spindle SLS must always be installed per side as a diagonal strut before the crane lifting gear is removed.

## Assembly of the supporting heavy-duty spindles SLS

1. Insert the appropriate heavy-duty spindle SLS (30) into the connection of the prop base VST 48 (17).
2. Connect the heavy-duty spindle SLS (30) to the bracing connector VST (8) and prop base VST 48 (17) by means of 1x fitting pin  $\varnothing$  21 mm (9) each. (Fig. B5.10)
3. Remove crane lifting gear from the spacers.

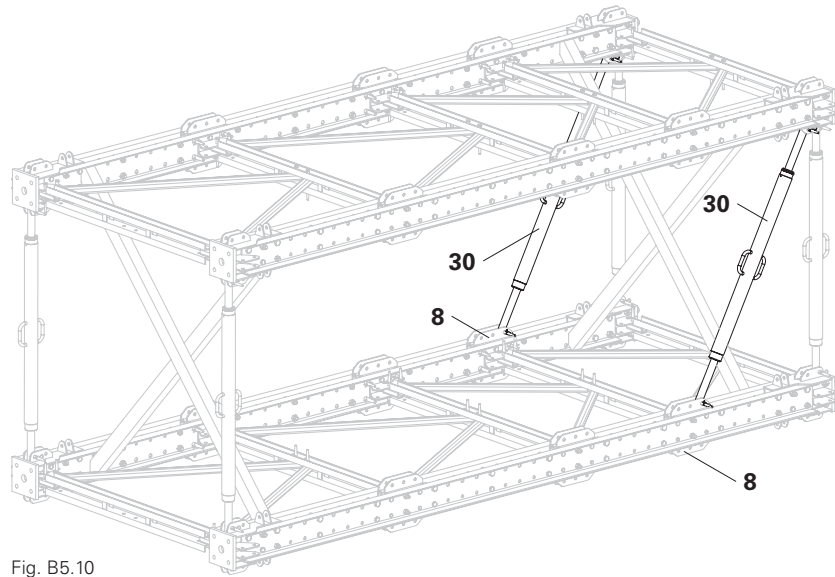

Fig. B5.10

## Assembly of the heavy-duty spindles SLS

1. Install the required number of heavy-duty spindles SLS (30) using fitting pins  $\varnothing$  21 mm (9). (Fig. B5.11)
2. Remove square timbers.

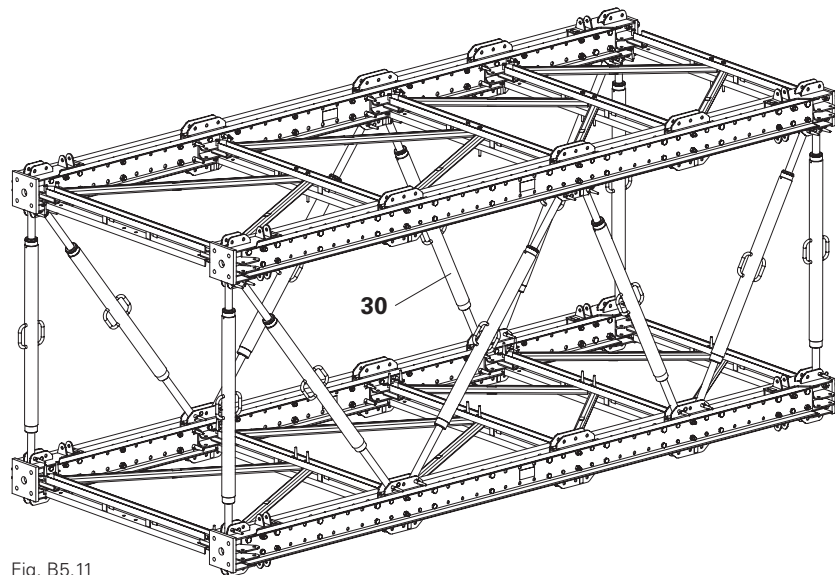

Fig. B5.11



## Warning

Unsecured or unsupported component prior to assembly!

An unsecured, unsupported component can topple over or collapse and result in serious injuries.

⇒ Prior to assembly, stability of the module must be guaranteed.

### Mounting the connector UP-VST

1. Insert 1x connector UP-VST (38a) from below into the horizontal ledger VST 200 (23a) as a horizontal bearing on the left and right.
2. Secure connectors UP-VST (38) with fitting pins Ø 21 mm (9) or PERI wedge K (40). (Fig. B6.01a + B6.01b)
3. Insert 1x connector UP-VST (38b) laterally into the horizontal ledger VST 200 (23b) as a vertical bearing on the left and right.
4. Secure connectors UP-VST (38) with fitting pins Ø 21 mm (9) or PERI wedge K (40). (Fig. B6.01a + B6.01b)

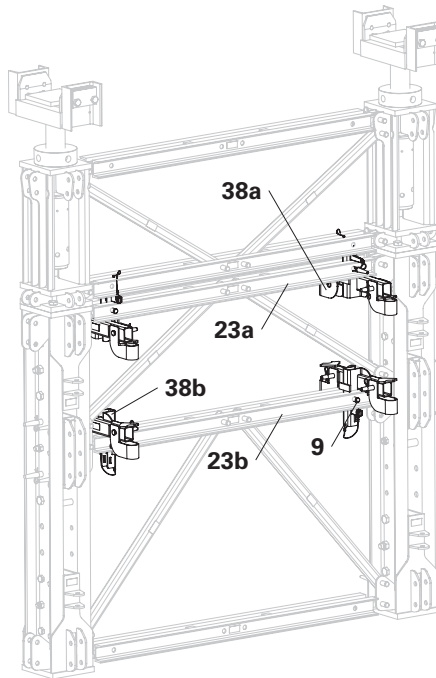

Fig. B6.01a

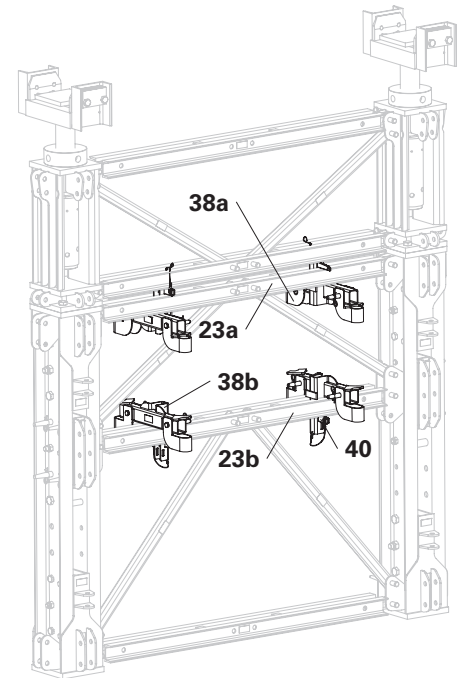

Fig. B6.01b

### Installation of the standard UVR

1. Place standard UVR 300 (46.1) (for VST 175: standard UVR 150 (46.2)) with the rosette on the connector UP-VST (38).
2. Mount retaining lug (38.1) to the bottom connector UP-VST (38) using bolts Ø 20 x 140 (39) and secure with cotter pins 4/1, galv.
3. Mount retaining lug (38.1) to the upper connector UP-VST (38) using bolts Ø 20 x 140 (39) and secure with cotter pins 4/1, galv.



Here, the rosette has to rest on the connector UP-VST (38) in order to safely transfer the forces. (Fig. B6.02a)

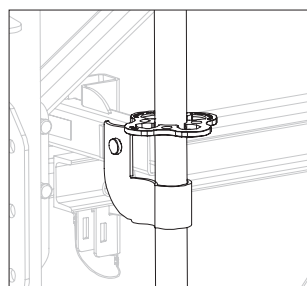

Fig. B6.02a

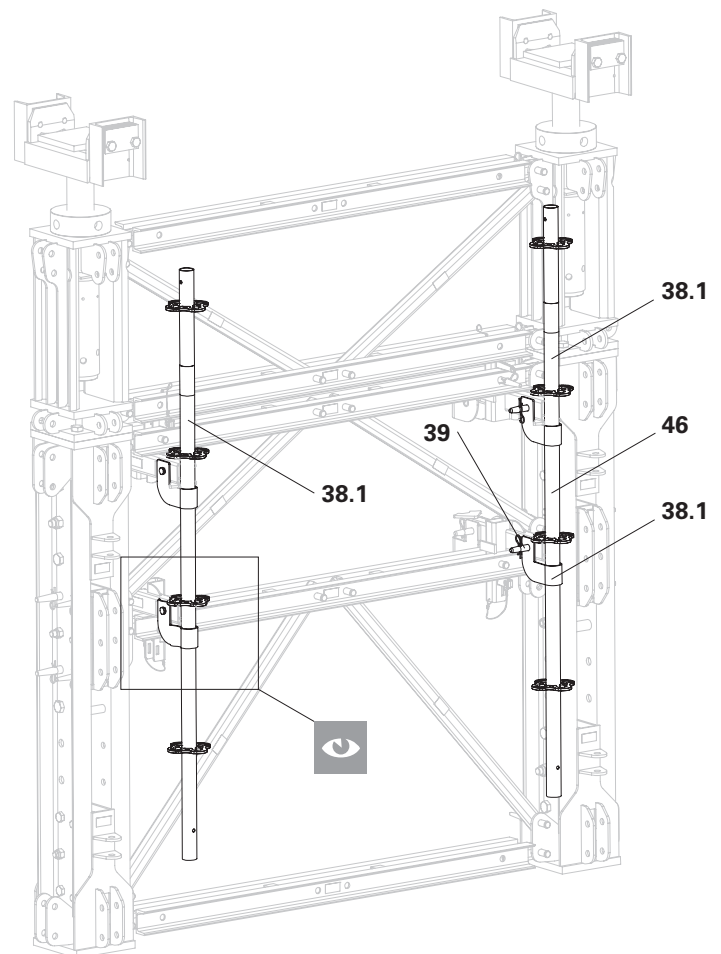

Fig. B6.02

## Installation of the ledger UH 150

1. Install the required ledgers UH 150 (47) between the standards UVR (46).

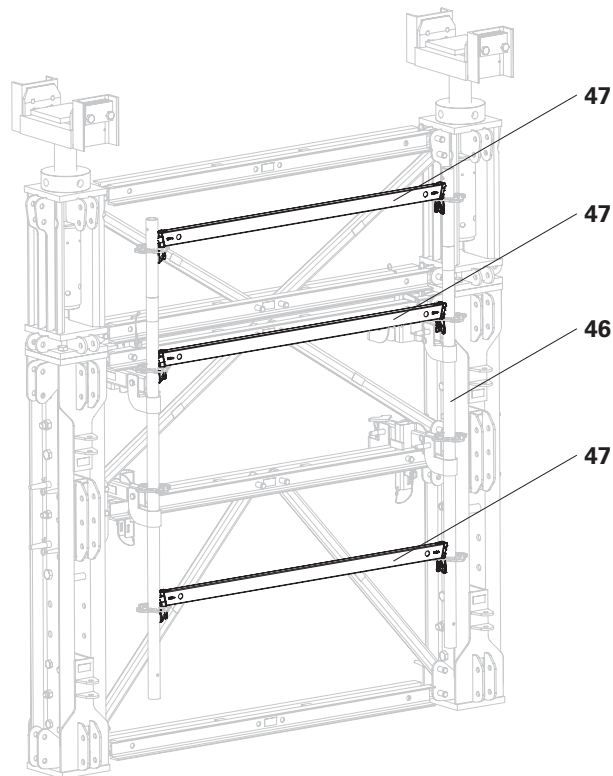

Fig. B6.03

## Warning

The system can only be declared as safe if project-specific planning is carried out. Otherwise, this can result in serious injuries.

- ⇒ Project-specific planning must be carried out for each working platform application.
- ⇒ See Instructions for Assembly and Use for PERI UP Flex.

## Installing the platform

1. Installation of the required brackets and standard components of the PERI UP system.

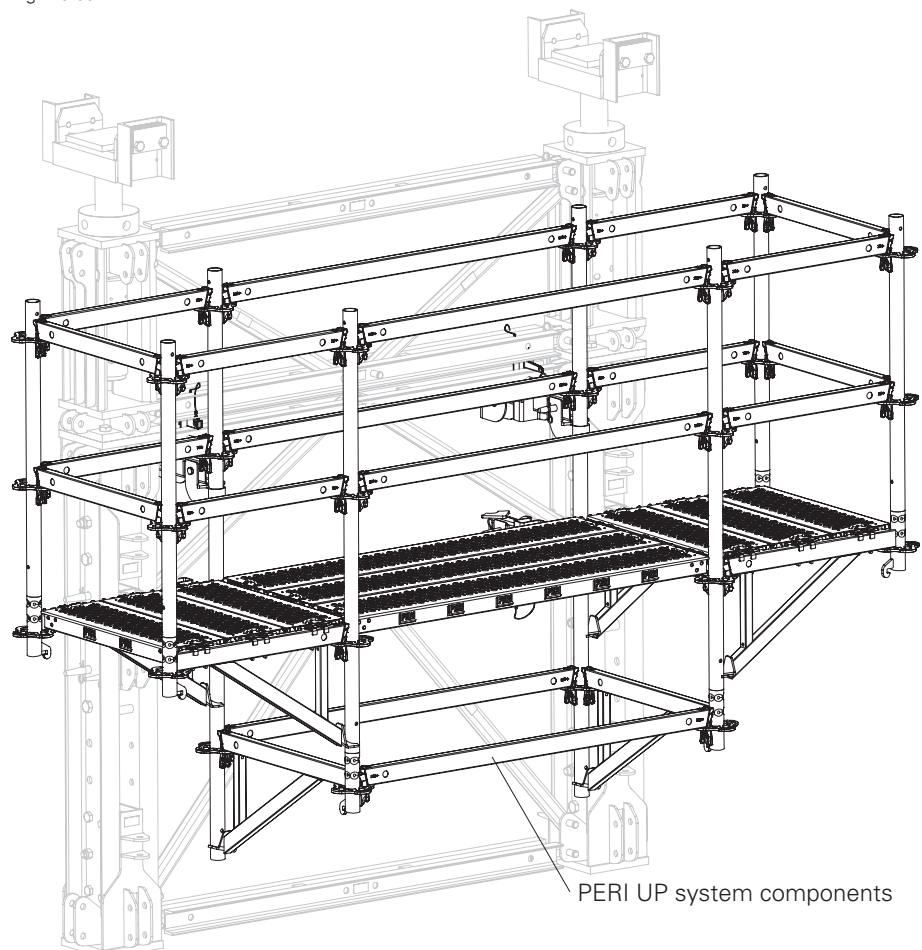

Fig. B6.04



## Danger

Incorrectly tackled heavy load!  
The heavy load can fall down and result in serious, irreversible injuries or even death.

- ⇒ Observe the information on attaching lifting gear in Section F4, Moving the towers.
- ⇒ Use textile lashing gear with sufficient load-bearing capacity.
- ⇒ When erecting the tower, ensure that no persons remain in the area of risk.
- ⇒ Standing under a suspended load is prohibited.
- ⇒ Temporary situations, e.g. with square timbers, must be secured.
- ⇒ Only one tower segment may be moved at any one time.



- For the installation, a crane or other lifting device as well as a level assembly surface is required.
- Intermediate states must be prevented from falling over using temporary bracing.
- Reserve an adequate area for interim storage.
- Additional assembly plans are required.
- For assembly, the use of lifting platforms or mobile scaffolds is recommended.
- In individual cases, the use of personal protective equipment may be necessary.

### Attaching to the crane

1. Attach lifting gear to the tower (see Section F4. Moving the towers).
2. Use the crane to tilt the tower over the prop base VST 48 (17).

### Erecting the tower

1. Slowly erect the tower until it is vertically positioned.



Use a rope to guide the tower.

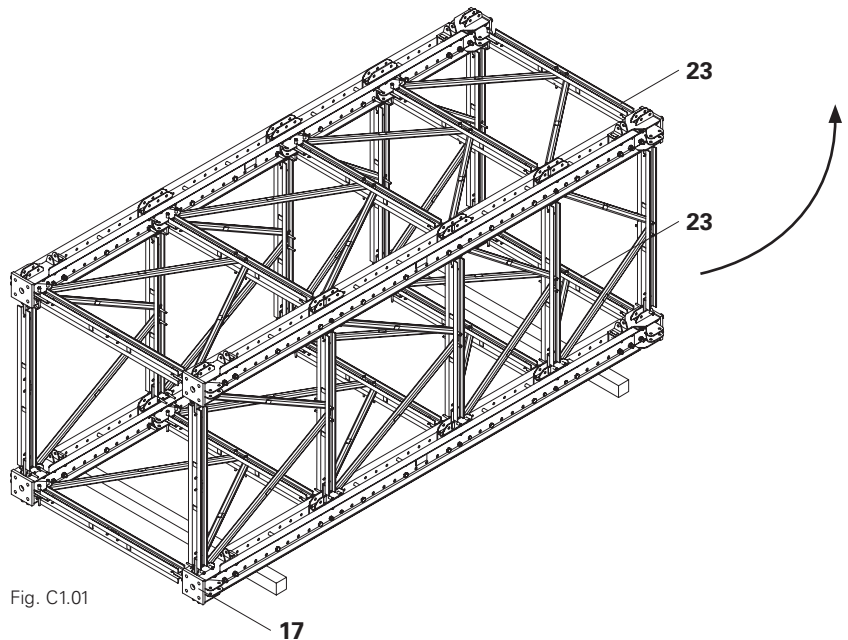

Fig. C1.01

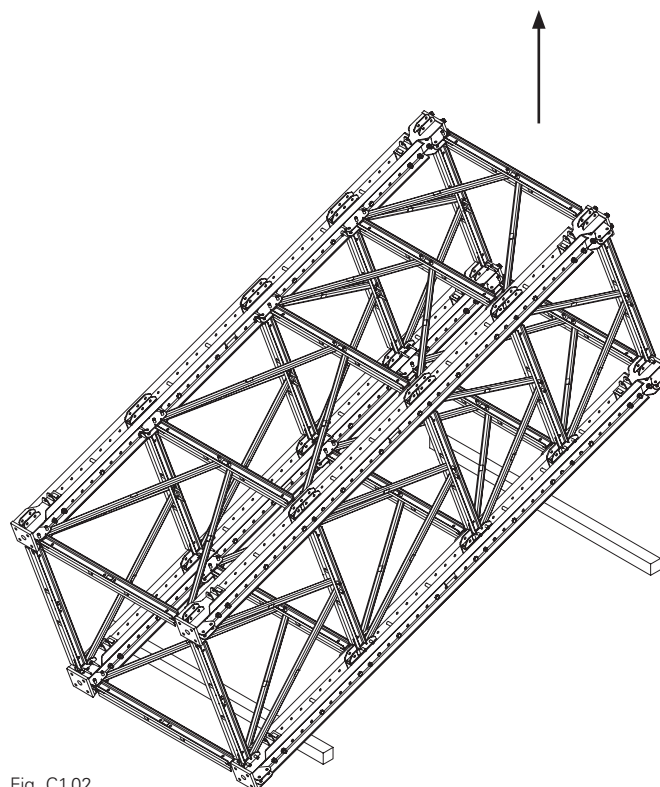

Fig. C1.02

## Moving the tower



- Check that the foundation is level and sufficiently load-bearing before lowering the tower.
- Any unevenness must be corrected by using cement grouting which has the same quality as the concrete. (See Section C3, Anchoring)

1. Lift the tower and set down on its designated position. (Fig. C1.02a)
2. Place the construction on the foundation and install anchors. (See Section C3, Anchoring)
3. Release tower from the crane lifting gear.

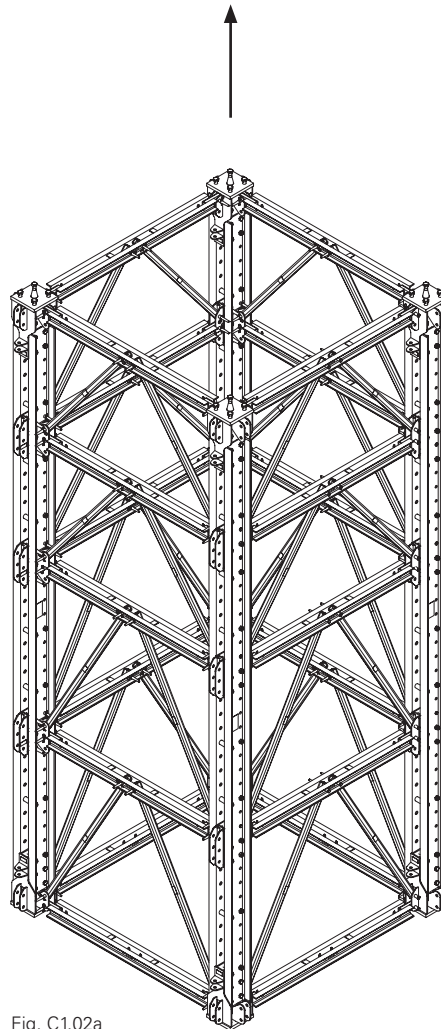

Fig. C1.02a

## Positioning on an existing tower



### Warning

Heavy moving loads when moving the towers!  
There is a risk of crushing for personnel which can result in serious injuries or even death.  
⇒ Keep a safe distance from the towers.



The towers centre themselves through the spigots of the prop connectors VST 48 (21).

1. Place tower on existing tower. (Fig. C1.02b)
2. Connect the supporting elements on all legs using four bolts each from the individual prop connectors VST 48 (21).
3. Release tower from the crane lifting gear.

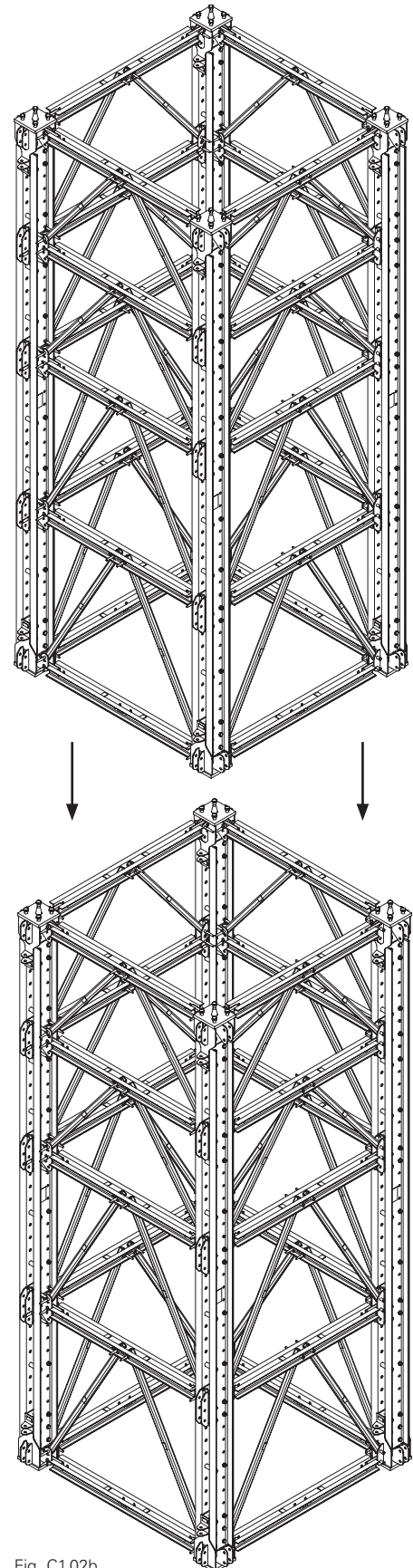

Fig. C1.02b



## Danger

Incorrectly tackled heavy load!

The heavy load can fall down and result in serious, irreversible injuries or even death.

- ⇒ Observe the information on attaching lifting gear in Section F3, Moving the modules.
- ⇒ Use textile lashing gear with sufficient load-bearing capacity.
- ⇒ When erecting the module, ensure that no persons remain in the area of risk.
- ⇒ Standing under a suspended load is prohibited.
- ⇒ Temporary situations, e.g. with square timbers, must be secured.
- ⇒ Only one module may be moved at any one time.

## Attaching to the crane

1. Attach lifting gear to the module (see Section F3, Moving the modules).
2. Use the crane to tilt the module over the prop base VST 48 (17).



Use a rope to guide the tower.

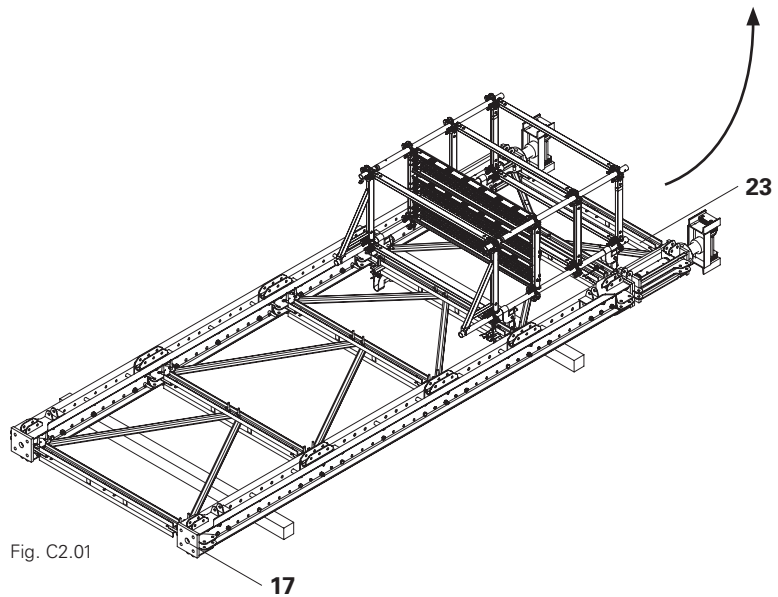

Fig. C2.01

## Erecting the tower

1. Slowly erect the module until it is vertically positioned.
2. Lift the module and set down on its designated position.

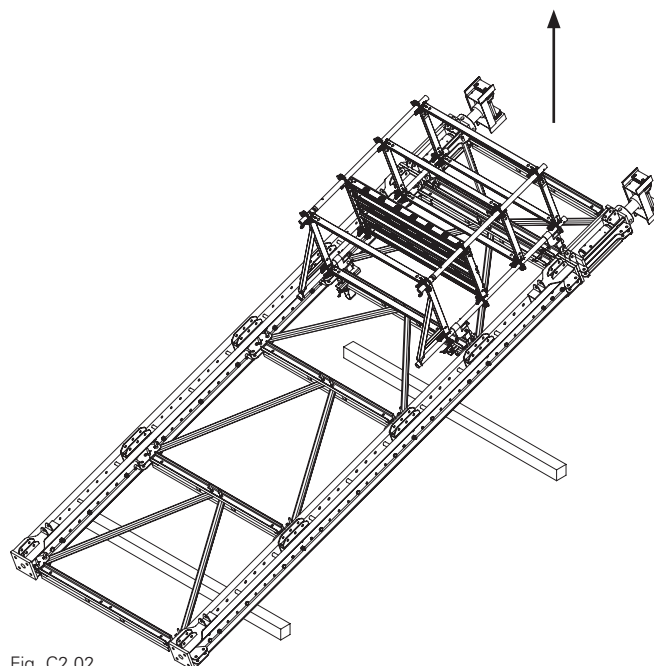

Fig. C2.02

## Erecting in front of a countersupport/ pier

### Warning

- Assembly from incomplete working platform! There is a risk of falling which can result in serious injuries or even death.
  - ⇒ Only access a working platform when the module has been anchored and secured.
- Assembly at great height! There is a risk of falling which can result in serious injuries or even death.
  - ⇒ Assembly work must be carried out from a safe position, such as a mobile scaffold.



- Anchor the module to the foundation. (See Section C3, Anchoring)
- In order to keep the module in a horizontal position, the anchor holes on the abutment/pier can be used, e.g. with steel waler SRU U120 (48) and heavy-duty spindle SLS (30). (Fig. C2.03)
- Observe the project-specific planning of the access points.

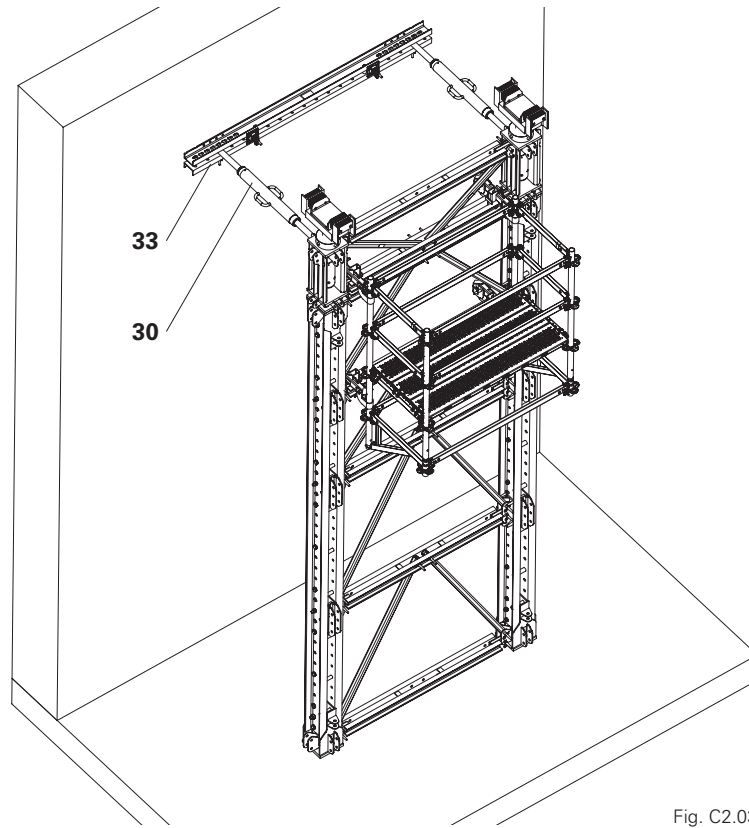

Fig. C2.03

## Securing on the foundation



- Anchor the module to the foundation. (See Section C3, Anchoring)
- Secure the module to the foundation using a heavy-duty spindle SLS (30).
- If module anchorage for the foundation is available, one heavy-duty spindle SLS (30a) in the bottom third is sufficient.
- If no module anchorage for the foundation is available, the heavy-duty spindle SLS (30b) must be mounted on the bracing connector VST (8) in the top third.

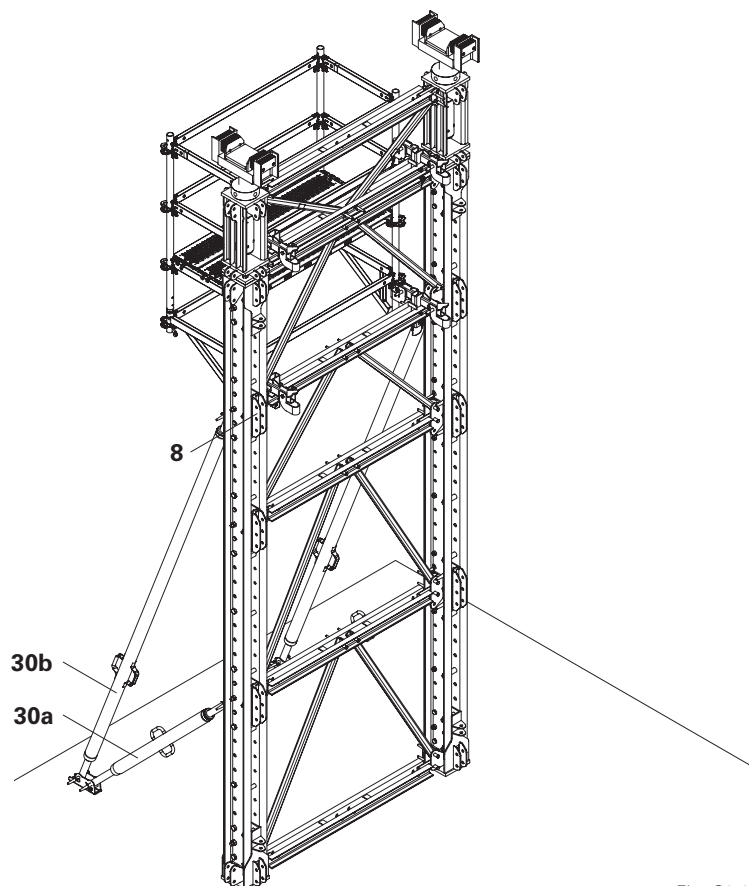

Fig. C2.04





Take into account the project-specific planning.

### Adding a second module

1. Lift the second module and set it down on its designated position (see Section F3, Moving the modules).
2. If required, anchor the module to the foundation.



Use a rope to guide the tower.

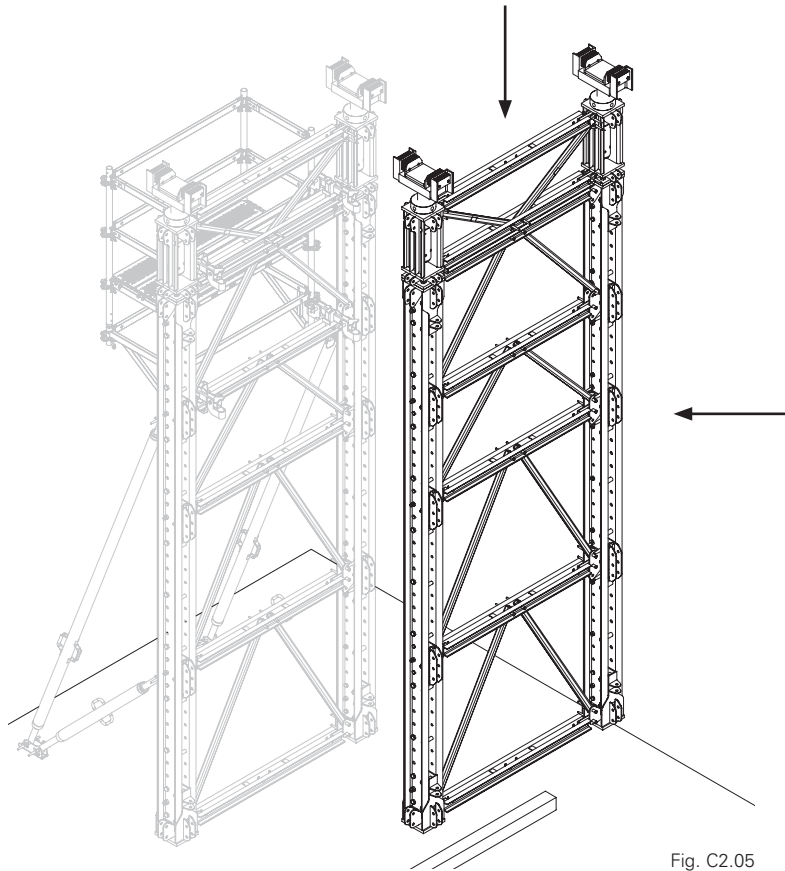

Fig. C2.05



### Warning

Assembly at great height! There is a risk of falling which can result in serious injuries or even death.

⇒ Assembly work must be carried out from a safe position, such as a mobile scaffold.

### Securing the second module

1. Mount the horizontal heavy-duty spindles SLS (30a) on the prop connector VST 48 (21) and adjust the spacing between the modules.
2. Install one heavy-duty spindle SLS (30b) as a diagonal strut for bracing the tower.
3. Detach crane lifting gear.

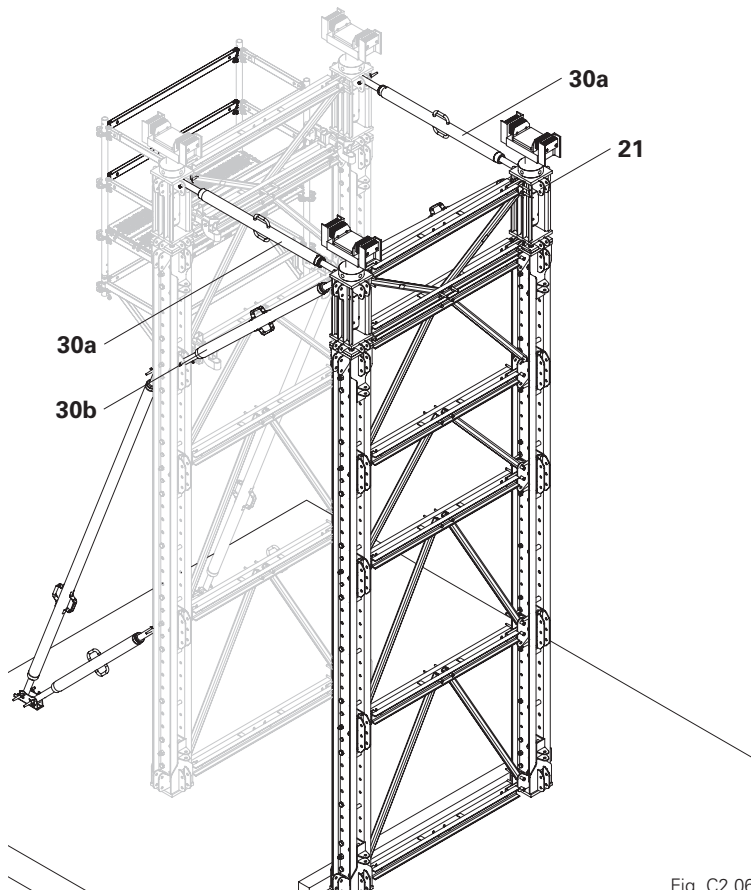

Fig. C2.06



## Warning

Assembly at great height! There is a risk of falling which can result in serious injuries or even death.

⇒ Assembly work must be carried out from a safe position, such as a mobile scaffold.

## Bracing the tower

1. Installation of the statically required heavy-duty spindles SL (30) for bracing the tower.

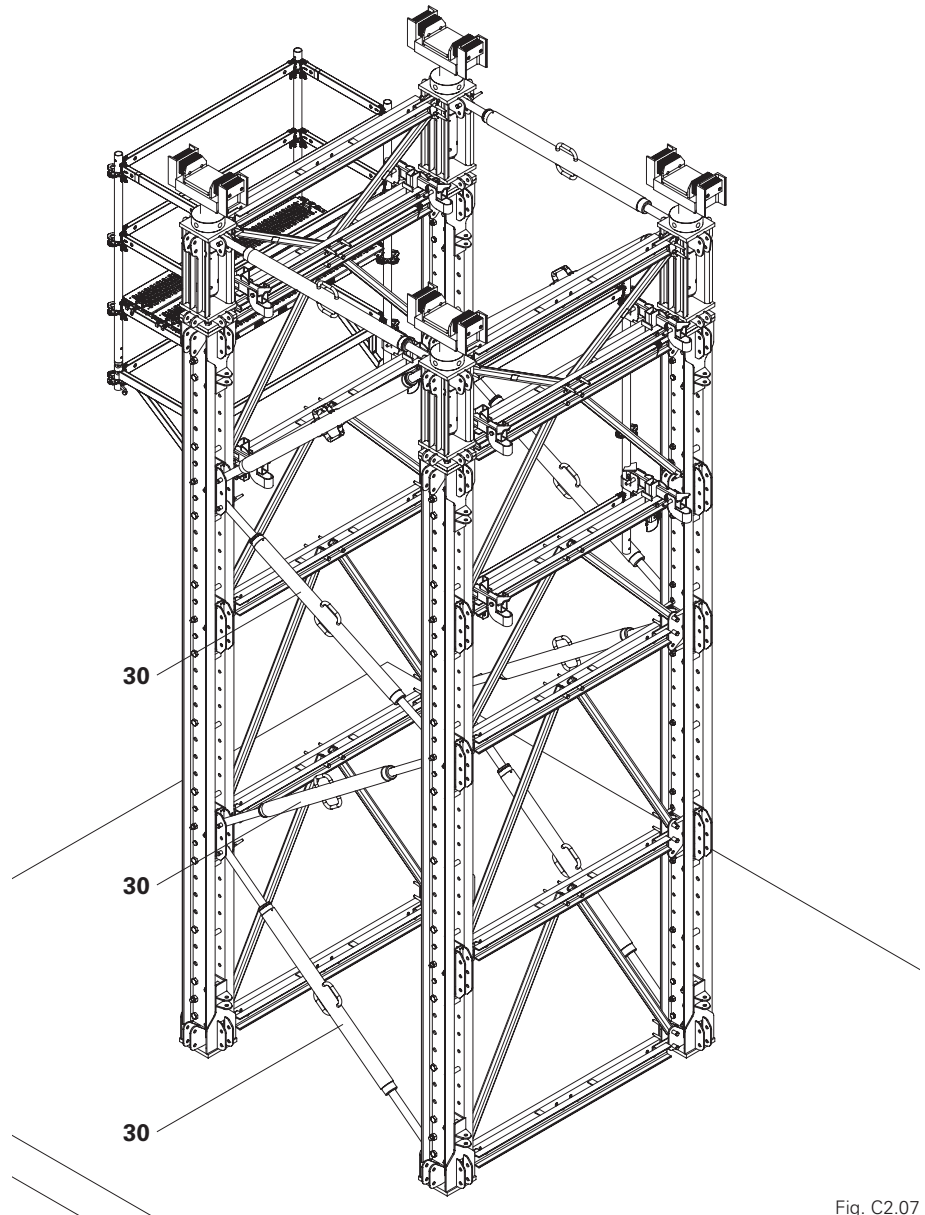

Fig. C2.07



## Warning

Components can be overloaded! There is a risk of collapse which can result in serious injuries or even death.

- ⇒ Built-in parts must have sufficient load-bearing capacity.
- ⇒ Observe the manufacturer's specifications.



- In order to achieve a full-surface contact between the foundation and the prop base VST 48 (17), the gap must be completely filled with non-shrinkable cement grouting.
- The quality of the cement grouting must correspond to the quality of the concrete.
- Project-specific verification is required.

### Version 1

- Anchoring the module with tie rod DW 15 (50) and cam nut DW 15 (51).
- The number of anchors must be statically calculated.

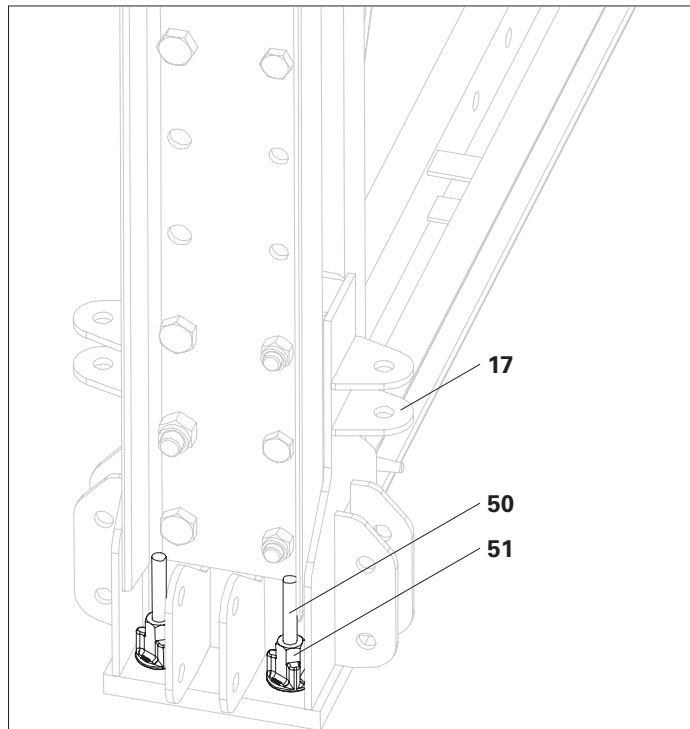

Fig. C3.01

### Version 2

- Anchoring the module with tie rod DW 26 (53), counterplate DW 26 (54) and hex. nut DW 26 SW 46/80, weldable (55).

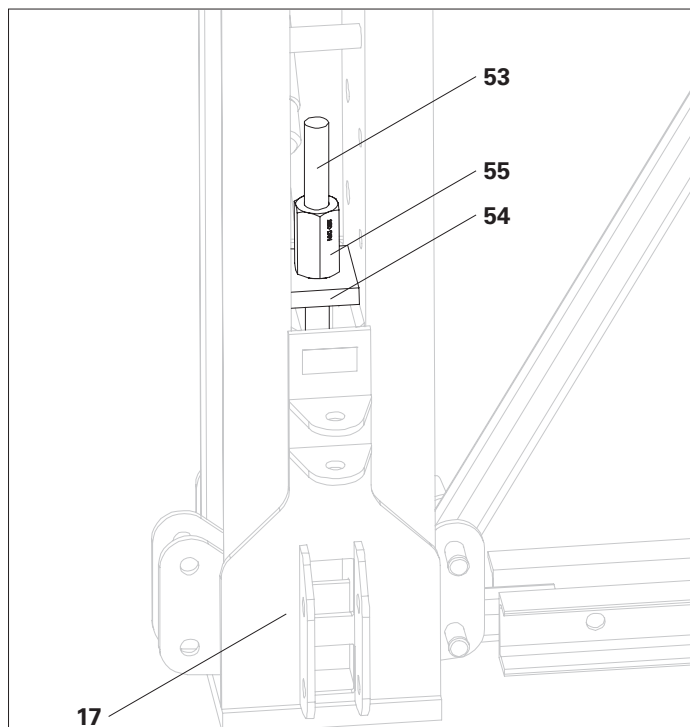

Fig. C3.03



## Danger

Lowering heavy loads! There is a risk of collapse which can result in serious injuries or even death.

- ⇒ Assembly work must be carried out from a safe position.
- ⇒ Project-specific lifting and lowering plans are to be observed.



## Warning

The payload is only achieved if the maximum spindling length measured from the base plate of the head spindle to the top edge of the bearing plate does not exceed 1138 mm.

Otherwise, this can result in serious injuries.

- ⇒ Holes in the spindle sleeve serve as a visual check. If the thread is visible through these holes, the head spindle is within the permissible range. If the thread cannot be seen, the permissible state must be established by means of suitable measures, e.g. packing under the main beams with compensating plates or installation of Height Adjusts VST 12.5 or 25, before the tower is loaded.



## Caution

Lowering heavy loads! There is a risk of crushing which can result in injuries.

- ⇒ Lowering is carried out from a safe working position.
- ⇒ Observe the Instructions for Use for the hydraulic head spindle unit VST.

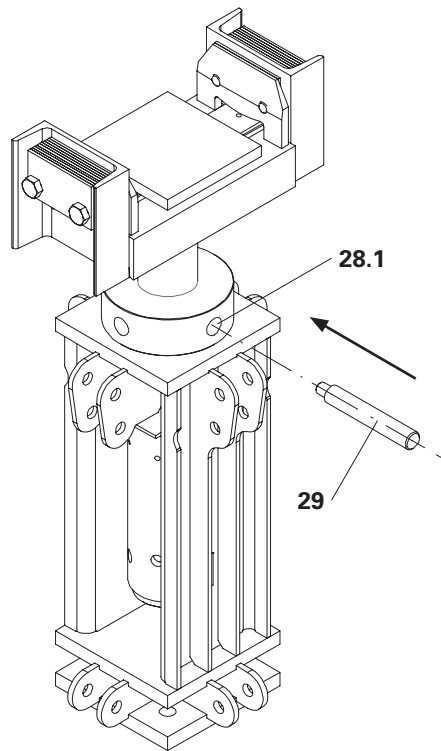

Fig. D1.01

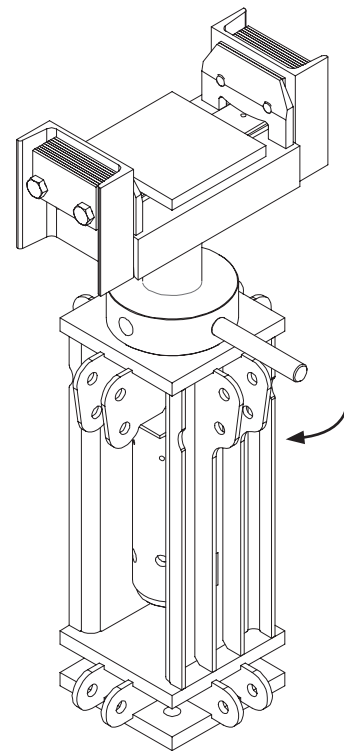

Fig. D1.02

## Manual adjustment



Observe the Instructions for Use for the hydraulic head spindle unit VST during all procedures.



One complete turn of the spindle nut results in a height adjustment of 12 mm.

1. Insert the mounting shaft VST (29) into the spindle nut (28.1). (Fig. D1.01)
2. Turn the mounting shaft VST (29) in a clockwise direction in order to spindle out the spindle head. (Fig. D1.02)

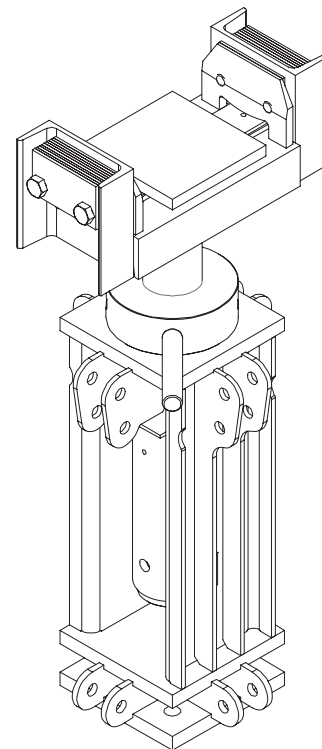

Fig. D1.03

# D1 Height adjustment (+/- 140 mm)

## Adjustment with the hydraulic cylinder



With the hydraulic cylinder, lifts of max. 10 mm per step are possible.

### Lifting

1. Insert the hydraulic cylinder (43.4) into the head spindle VST 100 (28).
2. Insert the mounting shaft VST (29) into the spindle sleeve (28.3). (Fig. D1.05)
3. Turn the spindle sleeve (28.3) with mounting shaft VST (29) in a clockwise direction until it rests against the hydraulic cylinder (43.4). (Fig. D1.06)
4. Lift the spindle with hydraulic cylinder (43.4).
5. Insert the mounting shaft VST (29) into the spindle nut (28.1). (Fig. D1.07)
6. Turn the mounting shaft VST (29) in a clockwise direction until the spindle nut (28.1) rests on the head plate.
7. Lower the hydraulic cylinder (43.4). (Fig. D1.08)
8. Repeat the procedure until the required height has been reached.

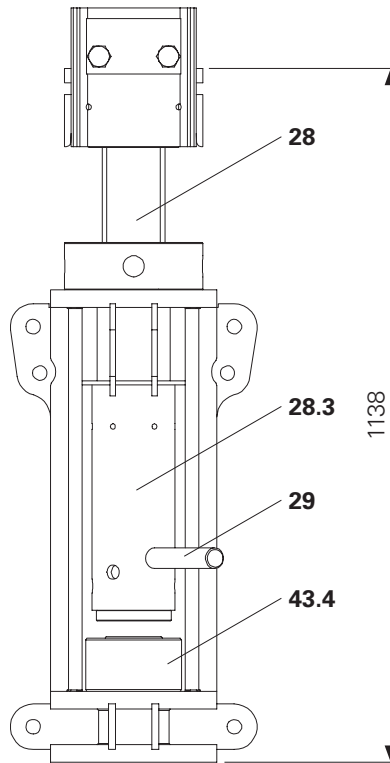

Fig. D1.05

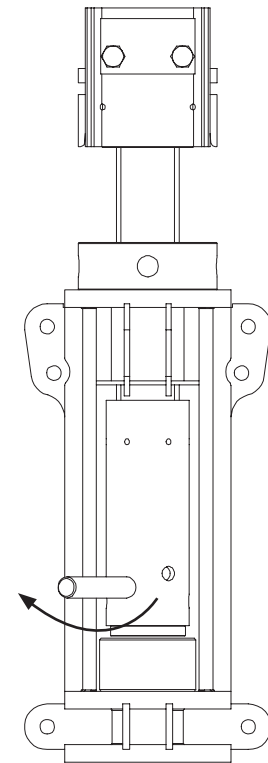

Fig. D1.06



Holes (28.4) in the spindle sleeve (28.3) serve as a visual check. When the thread is visible through these holes, the head spindle VST 100 (28) is within the permissible range. If this is not the case, appropriate measures must be taken in order to establish the permissible state. Suitable measures include, e.g.

- installation of height adjusts VST.

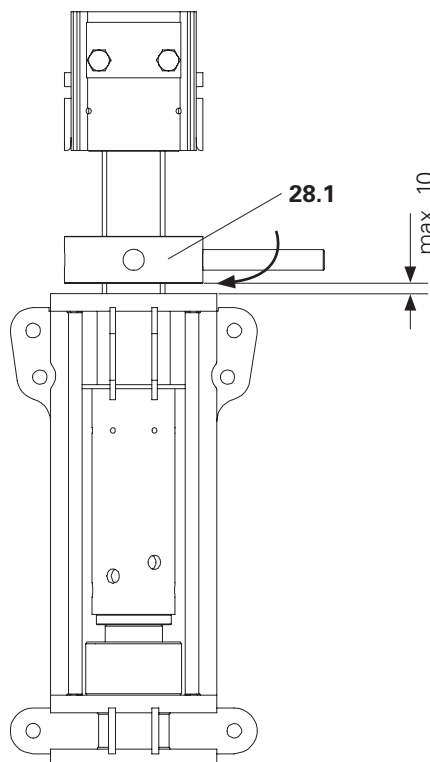

Fig. D1.07

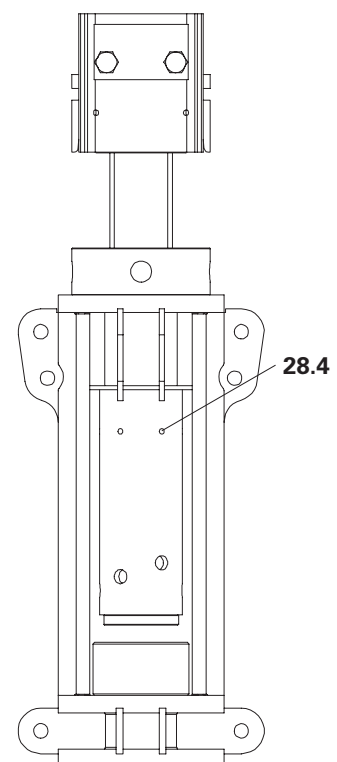

Fig. D1.08



## Caution

Lowering heavy loads! There is a risk of crushing which can result in injuries.

- ⇒ Lowering is carried out from a safe working position.
- ⇒ Observe the Instructions for Use for the hydraulic head spindle unit VST.



## Danger

Lowering heavy loads! There is a risk of collapse which can result in serious injuries or even death.

- ⇒ Assembly work must be carried out from a safe position.
- ⇒ Project-specific lifting and lowering plans are to be observed.

### Lowering with the hydraulic cylinder

1. Insert the mounting shaft VST (29) into the spindle sleeve (28.3).
2. Lower the spindle sleeve (28.3) with mounting shaft VST (29) until a 13 mm spacing is between the spindle sleeve (28.3) and hydraulic cylinder (43.4). (Fig. D2.01)
3. Completely extend the hydraulic cylinder (43.4) until the spindle nut (28.1) can freely move. (Fig. D2.02)
4. Insert the mounting shaft VST (29) into the spindle nut (28.2).
5. Turn the spindle nut (28.1) with mounting shaft VST (29) until there is a 10 mm spacing to the head plate.
6. Lower the hydraulic cylinder (43.4).



After the procedure, the spindle sleeve (28.3) must be able to move freely. If this is not the case, then the spacing between the spindle nut (28.1) and head plate is too large. In this case, lift the spindle and adjust the spindle nut (28.1) accordingly.

7. Repeat the procedure until the planned lowering range is reached.

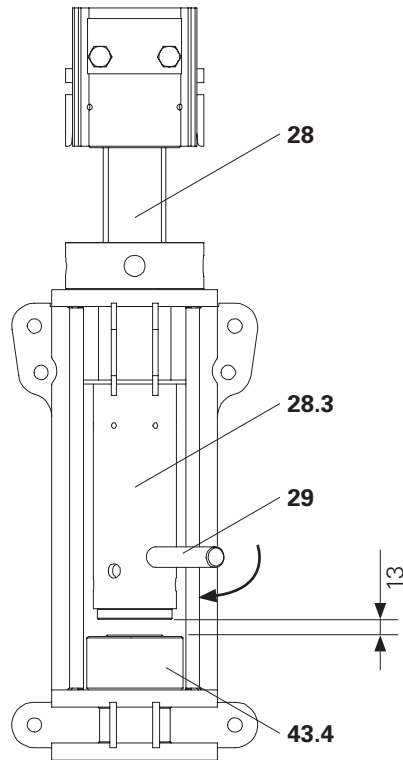

Fig. D2.01

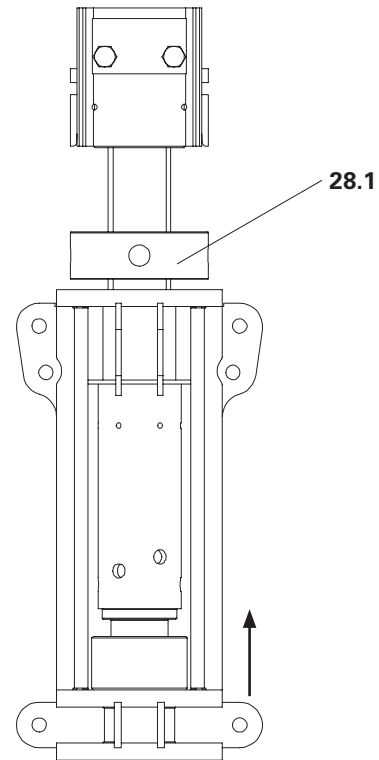

Fig. D2.02

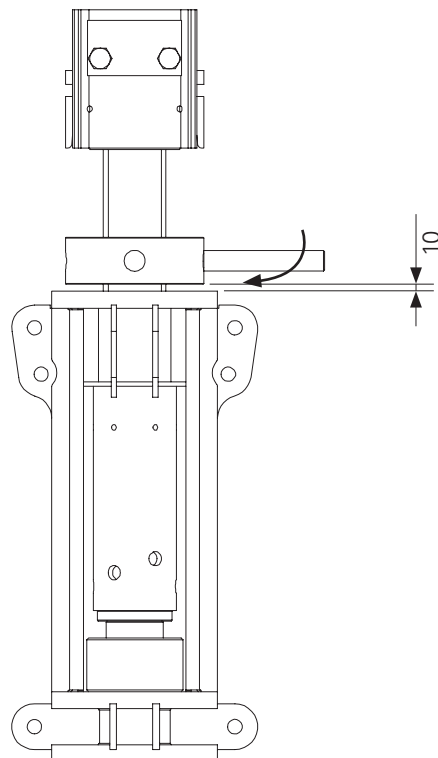

Fig. D2.03

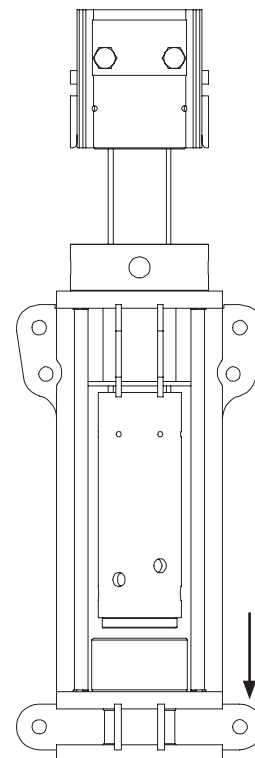

Fig. D2.04

## Preparing towers



### Danger

Incorrectly tackled heavy load!  
The heavy load can fall down and result in serious, irreversible injuries or even death.

- ⇒ Observe the information on attaching lifting gear in Section F4, Moving the towers.
- ⇒ A project-specific dismantling plan is required.
- ⇒ Use lashing gear with sufficient load-bearing capacity.
- ⇒ Standing under a suspended load is prohibited.



### Warning

Heavy, moving loads!  
There is a risk of crushing for personnel which can result in serious injuries or even death.

- ⇒ Keep a safe distance from the towers.
- ⇒ When lowering the module, ensure that no persons remain in the area of risk.



The procedure is valid for all towers.

### Preparing the attached tower

1. Attach the tower segment to the crane lifting gear.
2. Dismantle the connections between the towers from a safe working position.
3. Leave the danger area.
4. Lift off tower segment.
5. Place the tower segment on the ground for dismantling.
6. Remove crane lifting gear from the tower segment.

### Preparing the bottom tower segment

1. Attach the tower segment to the crane lifting gear.
2. Undo the anchoring.
3. Leave the danger area.
4. Tilt the tower segment and place it on the ground for dismantling.
5. Remove crane lifting gear from the tower segment.



Use a rope to guide the tower.

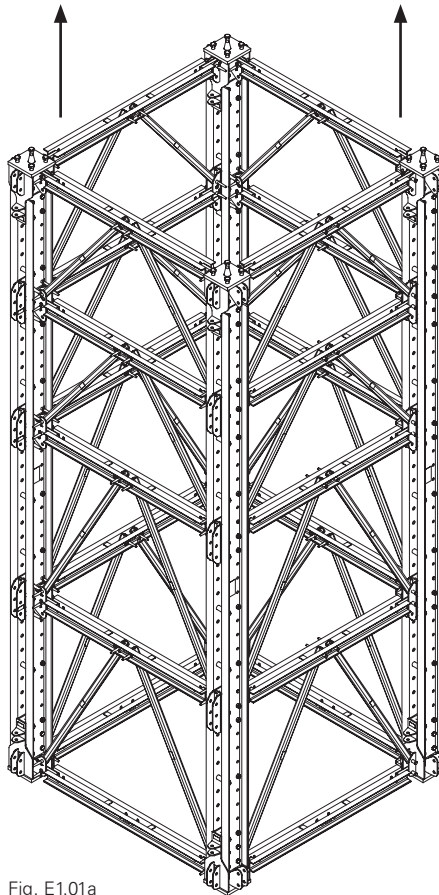

Fig. E1.01a

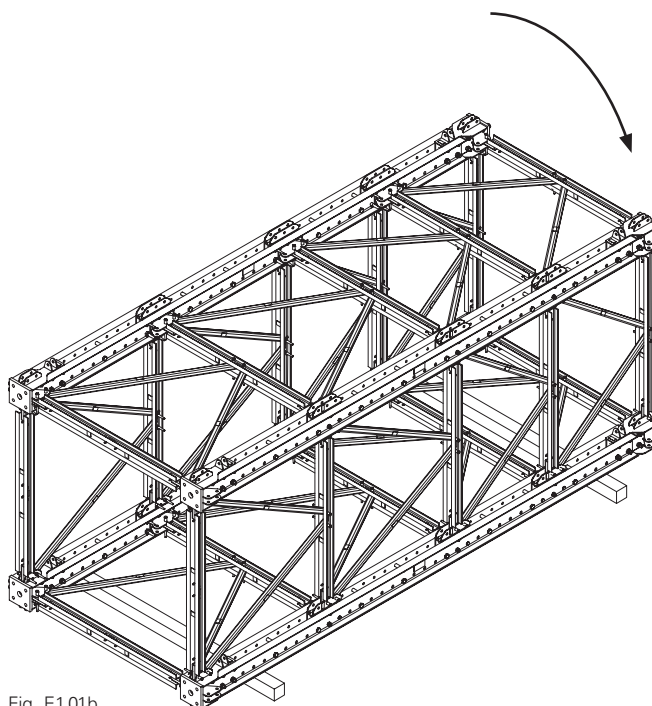

Fig. E1.01b

## Module preparation



### Danger

Incorrectly tackled heavy load!  
The heavy load can fall down and result in serious, irreversible injuries or even death.

- ⇒ Observe the information on attaching lifting gear in Section F3, Moving the modules.
- ⇒ Use lashing gear with sufficient load-bearing capacity.
- ⇒ When lowering the module, ensure that no persons remain in the area of risk.
- ⇒ Standing under a suspended load is prohibited.

### Preparation

1. Attach the module to the crane lifting gear.
2. Dismantle the connections and anchoring of the module.
3. Leave the danger area.
4. Lift the module.
5. Place the module on the ground for dismantling.
6. Remove crane lifting gear from the module.

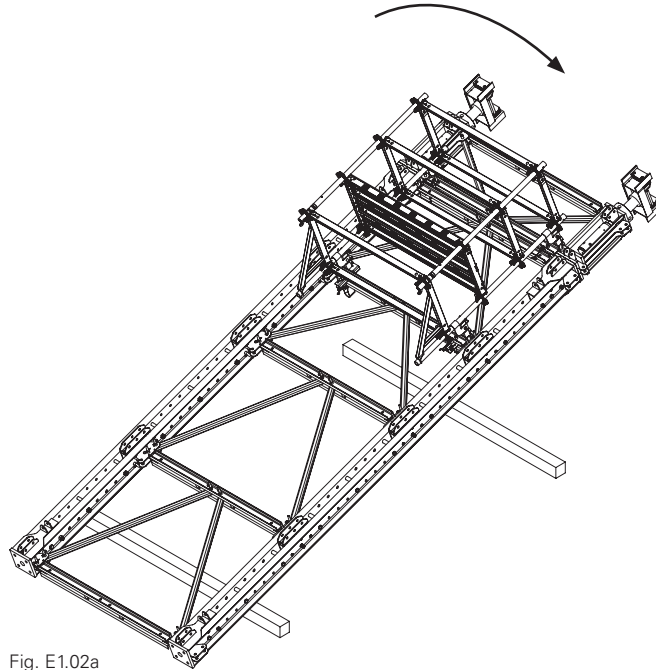

Fig. E1.02a

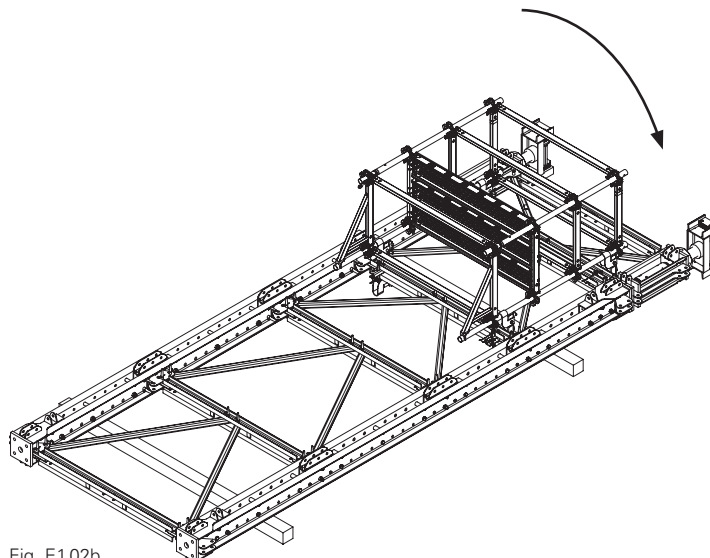

Fig. E1.02b



## Dismantling the tower



### Warning

Unsecured or unsupported component prior during dismantling!  
 An unsecured, unsupported component can topple over or collapse and result in serious injuries.  
 ⇒ Temporary situations, e.g. with square timbers, must be secured.



Vertical connecting elements (diagonal strut VST or heavy-duty spindles SLS) must be secured against tipping over during the dismantling procedure.

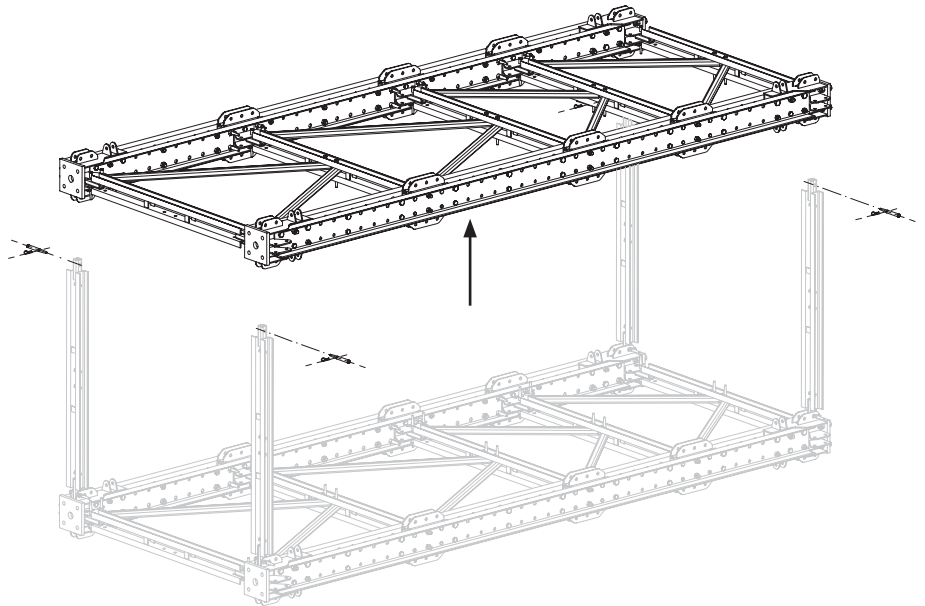

### Dismantling

1. Remove diagonal connecting elements.
2. Secure the top module with the crane.
3. Remove the fitting pins on the vertical connecting elements at the top.
4. Set the top module down on the ground.
5. Remove crane lifting gear from the module.
6. Remove vertical connecting elements.

## Dismantling the module



The individual components and their positions may be noted from the program overview.

1. Dismantle the module.
2. Place the spacers of the RCS rails in the correct position once again. (Fig. E1.04a + E1.04b)
3. Fit the VST components with the connection means again. (Fig. E1.05a + E1.05b)

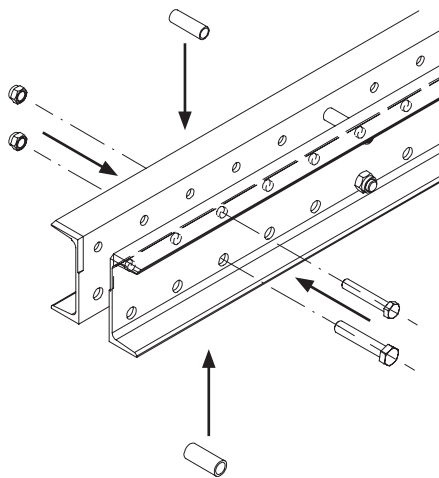

Fig. E1.04a

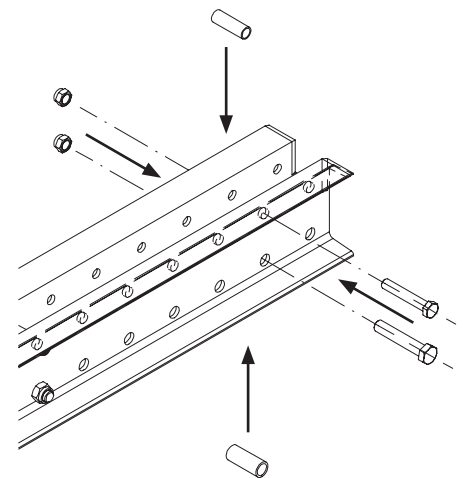

Fig. E1.04b

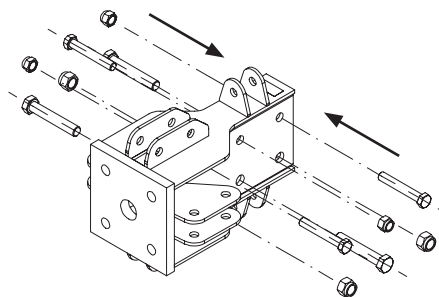

Fig. E1.05a

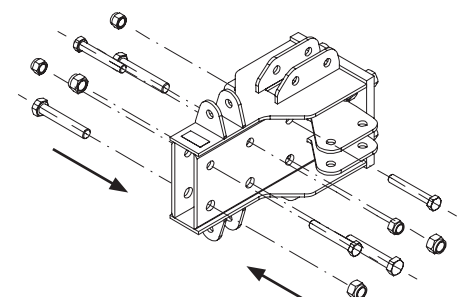

Fig. E1.05b

# F1 Pre-dimensioning of the permissible leg load at the head

## Warning

The system can only be declared as safe if project-specific planning is carried out. Otherwise, this can result in serious injuries.  
 ⇒ A detailed static calculation must be produced for each application.



The tower height and a horizontal load amounting to 2.5 % of the vertical load are taken into account.



Permissible leg loads for pre-dimensioning for a tower 2 x 2 m in accordance with configuration 1 (Section A11 - Tower configuration 1) whilst taking into account a horizontal load of  $F_H = 2.5 \% \times F_V$ .  
 (Fig. F1.02)

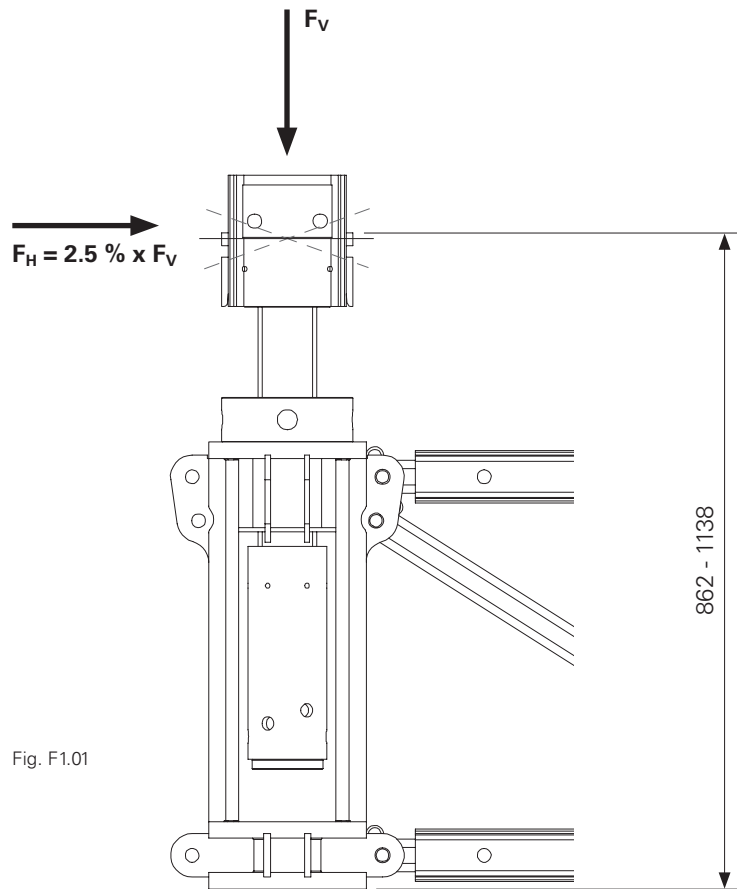

Fig. F1.01

## Maximum leg load [kN]

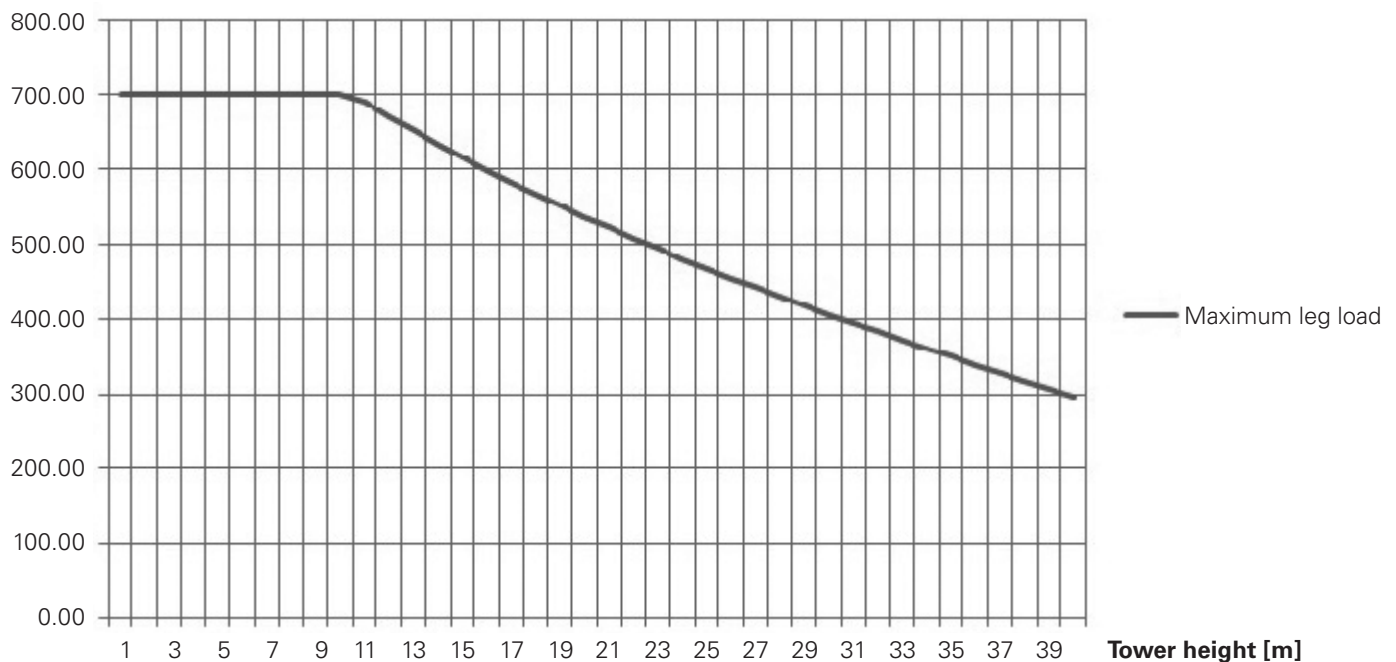

Fig. F1.02

## Load-bearing point of spacers:

### Spacer M20-82 (Art. no.: 110022)

Load-bearing capacity:  
perm. F = 3,000 kg

### Spacer M24-82 (Art. no.: 110023)

Load-bearing capacity:  
perm. F = 5,000 kg

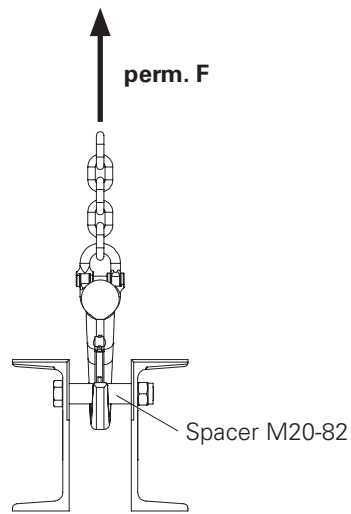

Fig. F2.01

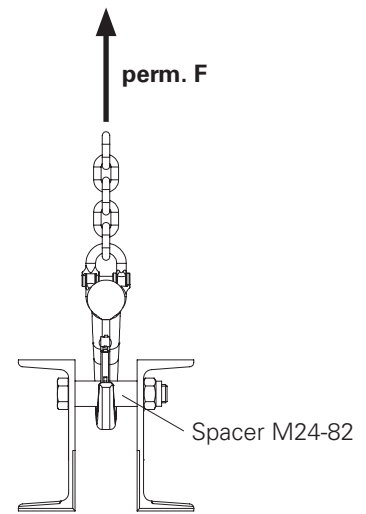

Fig. F2.02



## Warning

The system can only be declared as safe if project-specific planning is carried out. Otherwise, this can result in serious injuries.

⇒ In the case of heavier units, project-specific attachment points and assembly sequences must be determined.



- When erecting, half the weight of the module acts on the crane lifting gear.
- Use textile lashing gear with sufficient load-bearing capacity.

## Without head spindle frames

The lifting gear is attached to 4 lifting pins  $\text{Ø } 21 \times 120$  (9) which are mounted on the prop connector VST 48 (21). (Fig. F3.03a)

## Chain inclination angle

$\alpha = \text{max. } 30^\circ$

(Fig. F3.02)

## per load-bearing point (fitting pin $\text{Ø } 21 \times 120$ )

perm. F = 640 kg

(Fig. F3.04)

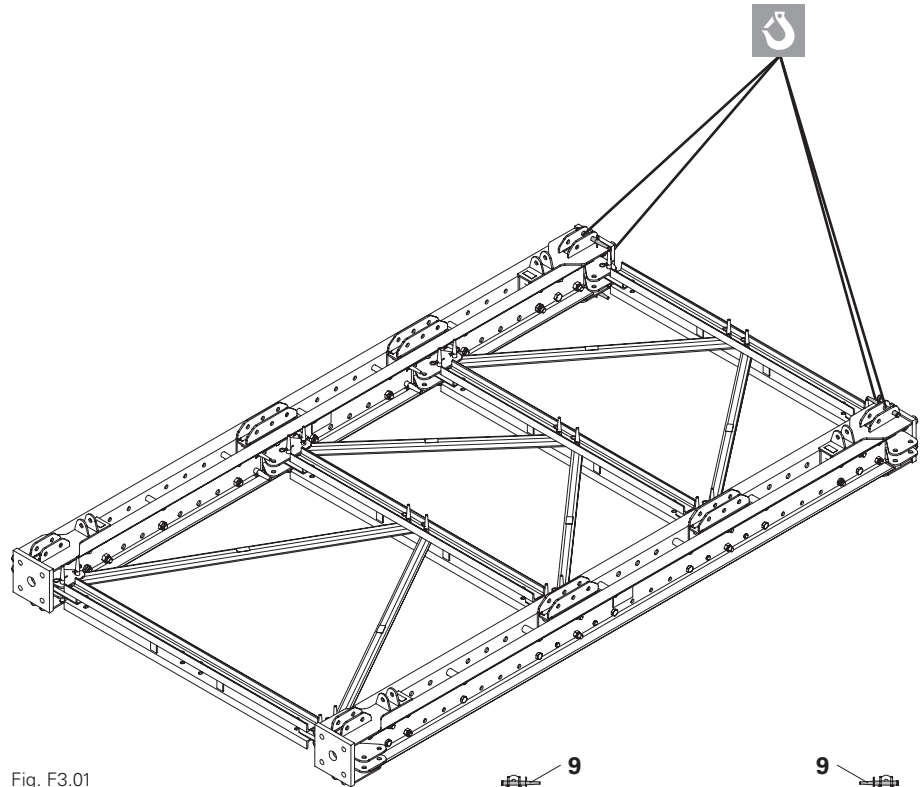

Fig. F3.01

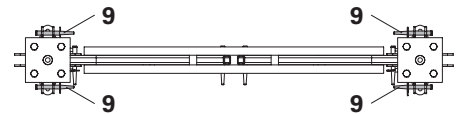

Fig. F3.03

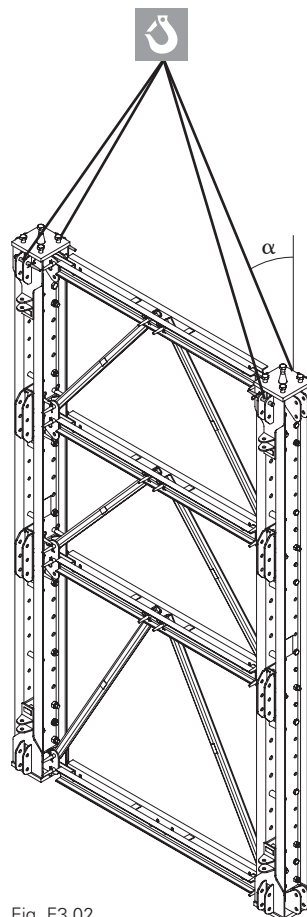

Fig. F3.02

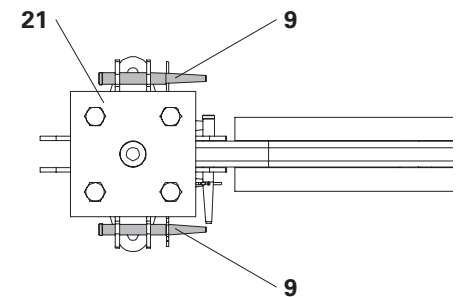

Fig. F3.03a

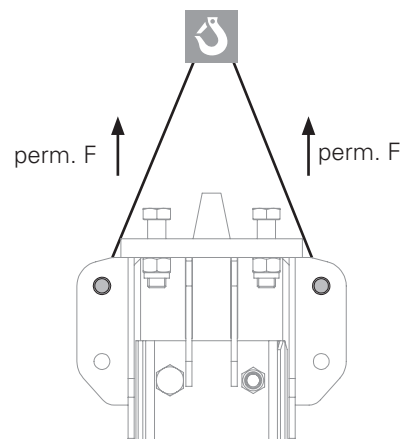

Fig. F3.04

## With head spindle frames

The lifting gear is connected underneath the diagonal struts VST 200/62.5 (27).  
(Fig. F3.05)

### Chain inclination angle

$\alpha = \max. 30^\circ$

(Fig. F3.06)

### per load-bearing point (Diagonal strut VST)

perm.  $F = 6.4 \text{ kN}$   
(Fig. F3.07)

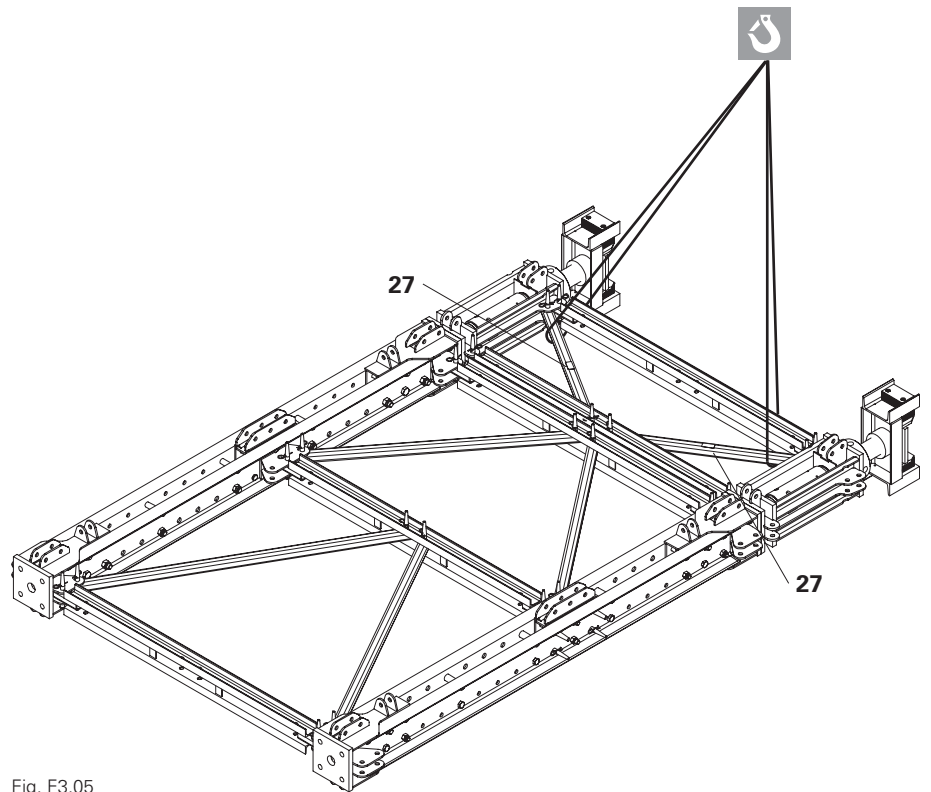

Fig. F3.05

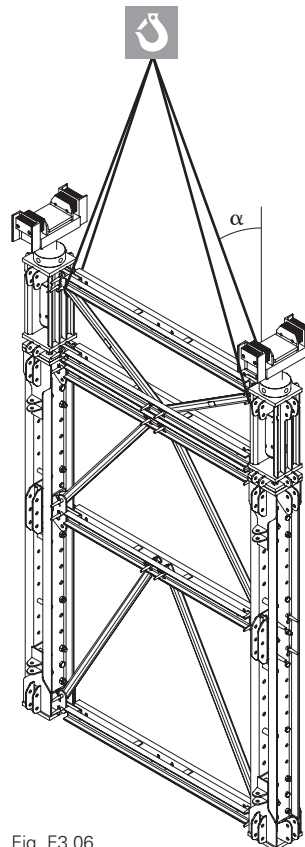

Fig. F3.06

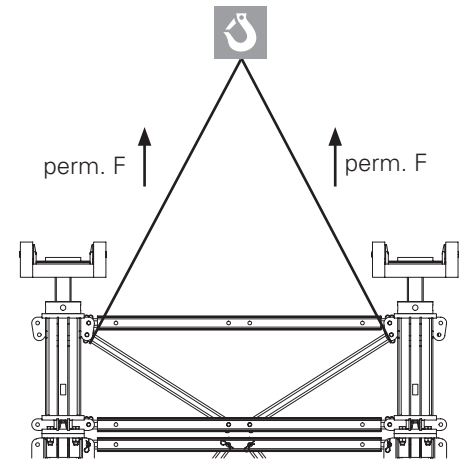

Fig. F3.07



## Warning

The system can only be declared as safe if project-specific planning is carried out. Otherwise, this can result in serious injuries.

⇒ In the case of heavier units, project-specific attachment points and assembly sequences must be determined.



- When erecting, half the weight of the tower acts on the crane lifting gear.
- Use textile lashing gear with sufficient load-bearing capacity.

## Without head spindle frames



When the tower is erected, the chain is redirected over the head plate. Therefore, the tower is carefully erected and directed in a forward direction.

The lifting gear is attached to 4 lifting pins  $\text{Ø } 21 \times 120$  (9) which are mounted on the prop connector VST 48 (21). (Fig. F4.03)

## Chain inclination angle

$\alpha = \text{max. } 30^\circ$

(Fig. F4.02)

## per load-bearing point (Fitting pin $\text{Ø } 21 \times 120$ )

perm. F = 640 kg  
(Fig. F4.04)

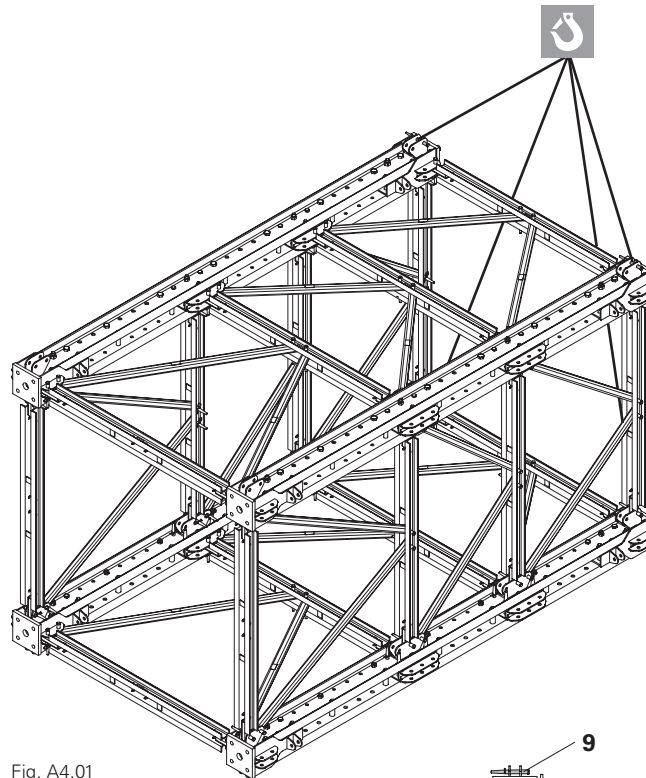

Fig. A4.01

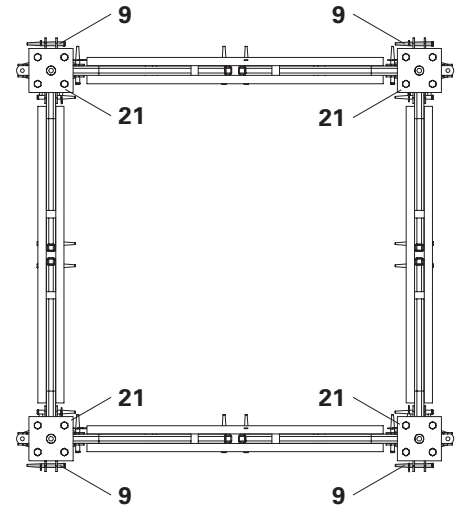

Fig. A4.03

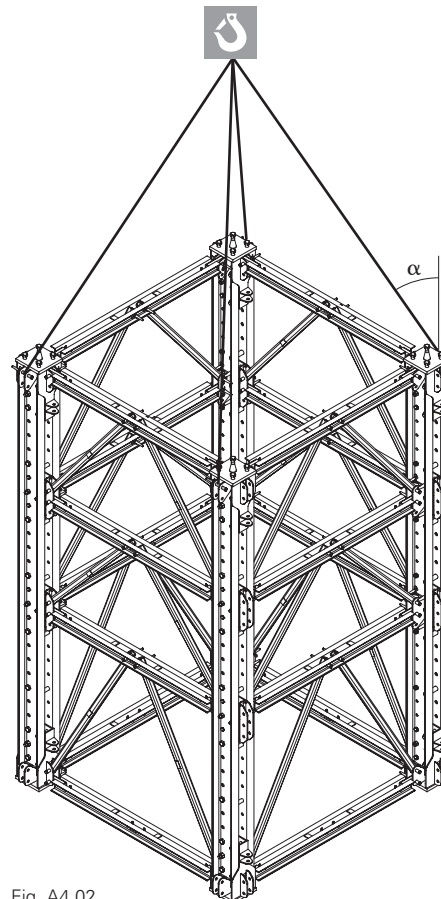

Fig. A4.02

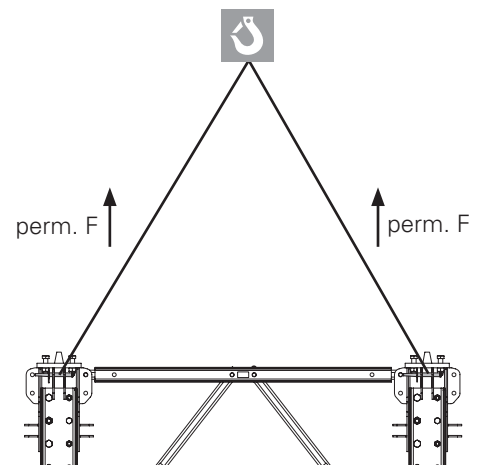

Fig. A4.04

## With head spindle frames

The lifting gear is connected underneath the diagonal struts VST 200/62.5 (27).  
(Fig. F4.05)

**Chain inclination angle**  
 $\alpha = \max. 30^\circ$

(Fig. F4.06)

**per load-bearing point  
(Diagonal strut VST)**  
perm. F = 640 kg  
(Fig. F4.07)

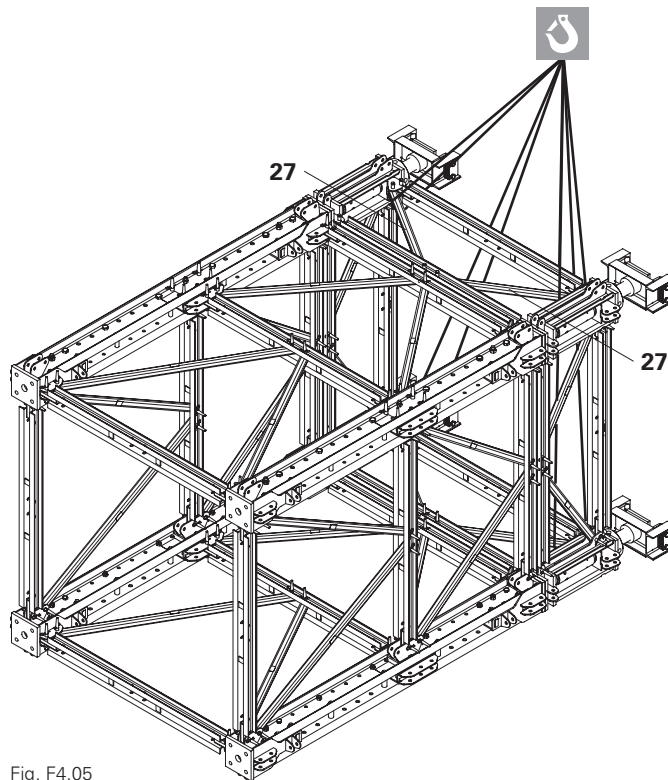

Fig. F4.05

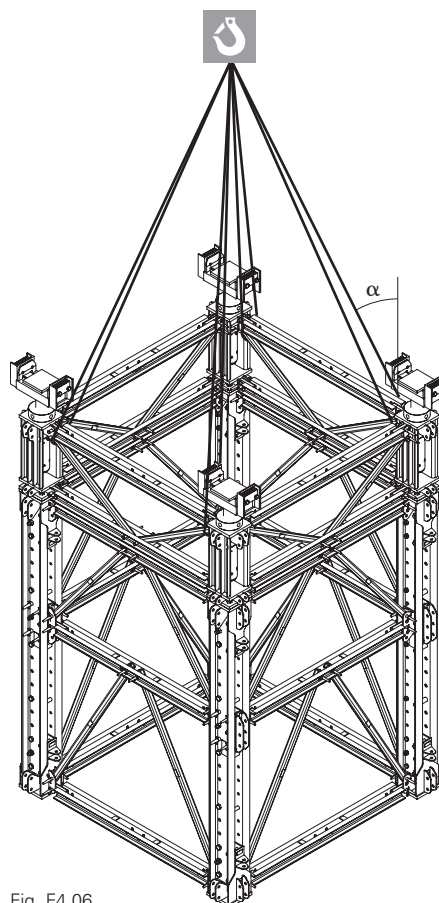

Fig. F4.06

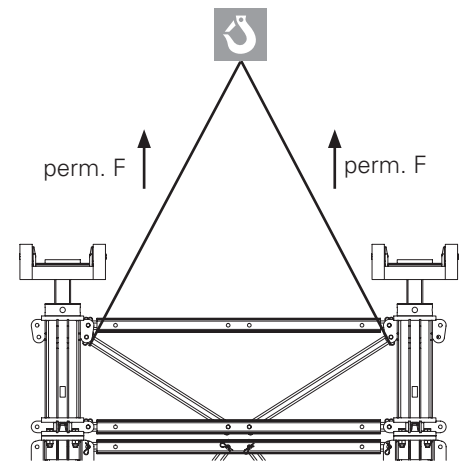

Fig. F4.07

# F5 Combination table 225 – 987.5 cm



Height			Height compensation		Head spindle	Modules						
h <sub>nom</sub>	min	max	12.5	25	100	125	175	275	375	525	775	1025
					±13.8 cm							
225	211.2	238.8			1	1						
237.5	223.7	251.3	1		1	1						
250	236.2	263.8		1	1	1						
262.5	248.7	276.3	1	1	1	1						
275	261.2	288.8			1		1					
287.5	273.7	301.3	1		1		1					
<b>300</b>	286.2	313.8		1	1		1					
312.5	298.7	326.3	1	1	1		1					
325	311.2	338.8		2	1		1					
337.5	323.7	351.3	1	2	1		1					
350	336.2	363.8			1	2						
362.5	348.7	376.3	1		1	2						
375	361.2	388.8			1			1				
387.5	373.7	401.3	1		1			1				
<b>400</b>	386.2	413.8			1	1	1					
412.5	398.7	426.3	1		1	1	1					
425	411.2	438.8		1	1	1	1					
437.5	423.7	451.3	1	1	1	1	1					
450	436.2	463.8			1		2					
462.5	448.7	476.3	1		1		2					
475	461.2	488.8			1				1			
487.5	473.7	501.3	1		1				1			
<b>500</b>	486.2	513.8		1	1				1			
512.5	498.7	526.3	1	1	1				1			
525	511.2	538.8		1	1	1		1				
537.5	523.7	551.3	1	1	1	1		1				
550	536.2	563.8			1		1	1				
562.5	548.7	576.3	1		1		1	1				
575	561.2	588.8			1	1	2					
587.5	573.7	601.3	1		1	1	2					
<b>600</b>	586.2	613.8			1	1			1			
612.5	598.7	626.3	1		1	1			1			
625	611.2	638.8			1					1		
637.5	623.7	651.3	1		1					1		
650	636.2	663.8		1	1					1		
662.5	648.7	676.3	1	1	1					1		
675	661.2	688.8		1	1		1		1			
687.5	673.7	701.3	1	1	1		1		1			
<b>700</b>	686.2	713.8			1	2	2					
712.5	698.7	726.3	1		1	2	2					
725	711.2	738.8			1	2			1			
737.5	723.7	751.3	1		1	2			1			



# F5 Combination table 225 – 987.5 cm

Height			Height compensation		Head spindle	Modules						
$h_{nom}$	min	max	12.5	25	100	125	175	275	375	525	775	1025
					$\pm 13.8$ cm							
750	736.2	763.8			1	1				1		
762.5	748.7	776.3	1		1	1				1		
775	761.2	788.8		1	1	1				1		
787.5	773.7	801.3	1	1	1	1				1		
<b>800</b>	786.2	813.8			1		1			1		
812.5	798.7	826.3	1		1		1			1		
825	811.2	838.8		1	1		1			1		
837.5	823.7	851.3	1	1	1		1			1		
850	836.2	863.8			1				2			
862.5	848.7	876.3	1		1				2			
875	861.2	888.8			1						1	
887.5	873.7	901.3	1		1						1	
<b>900</b>	886.2	913.8		1	1						1	
912.5	898.7	926.3	1	1	1						1	
925	911.2	938.8		1	1			1		1		
937.5	923.7	951.3	1	1	1			1		1		
950	936.2	963.8		1	1	1	1			1		
962.5	948.7	976.3	1	1	1	1	1			1		
975	961.2	988.8			1	1			2			
987.5	973.7	1001.3	1		1	1			2			

Tab. F5.01

For lowering, a remaining distance for the spindle of approx. 8 cm is to be planned.

# F6 Combination table 1,000 – 1,987.5 cm



Height			Height compensation		Head spindle	Modules						
$h_{nom}$	min	max	12.5	25	100	125	175	275	375	525	775	1025
					±13.8 cm							
<b>1000</b>	986.2	1013.8			1	1					1	
1012.5	998.7	1026.3	1		1	1					1	
1025	1011.2	1038.8		1	1	1					1	
1037.5	1023.7	1051.3	1	1	1	1					1	
1050	1036.2	1063.8			1		1				1	
1062.5	1048.7	1076.3	1		1		1				1	
1075	1061.2	1088.8		1	1		1				1	
1087.5	1073.7	1101.3	1	1	1		1				1	
<b>1100</b>	1086.2	1113.8		1	1		1	1		1		
1112.5	1098.7	1126.3	1	1	1		1	1		1		
1125	1111.2	1138.8			1							1
1137.5	1123.7	1151.3	1		1							1
1150	1136.2	1163.8		1	1							1
1162.5	1148.7	1176.3	1	1	1							1
1175	1161.2	1188.8		1	1					2		
1187.5	1173.7	1201.3	1	1	1					2		
<b>1200</b>	1186.2	1213.8		1	1			2		1		
1212.5	1198.7	1226.3	1	1	1			2		1		
1225	1211.2	1238.8			1				3			
1237.5	1223.7	1251.3	1		1				3			
1250	1236.2	1263.8			1				1		1	
1262.5	1248.7	1276.3	1		1				1		1	
1275	1261.2	1288.8		1	1				1		1	
1287.5	1273.7	1301.3	1	1	1				1		1	
<b>1300</b>	1286.2	1313.8			1		1					1
1312.5	1298.7	1326.3	1		1		1					1
1325	1311.2	1338.8		1	1		1					1
1337.5	1323.7	1351.3	1	1	1		1					1
1350	1336.2	1363.8		2	1		1					1
1362.5	1348.7	1376.3	1	2	1		1					1
1375	1361.2	1388.8			1	1			1		1	
1387.5	1373.7	1401.3	1		1	1			1		1	
<b>1400</b>	1386.2	1413.8			1					1	1	
1412.5	1398.7	1426.3	1		1					1	1	
1425	1411.2	1438.8		1	1					1	1	
1437.5	1423.7	1451.3	1	1	1					1	1	
1450	1436.2	1463.8		1	1		1		1		1	
1462.5	1448.7	1476.3	1	1	1		1		1		1	
1475	1461.2	1488.8			1		2					1
1487.5	1473.7	1501.3	1		1		2					1
<b>1500</b>	1486.2	1513.8			1				1			1
1512.5	1498.7	1526.3	1		1				1			1

# F6 Combination table 1,000 – 1,987.5 cm

Height			Height compensation		Head spindle	Modules						
h <sub>nom</sub>	min	max	12.5	25	100	125	175	275	375	525	775	1025
					±13.8 cm							
1525	1511.2	1538.8		1	1				1			1
1537.5	1523.7	1551.3	1	1	1				1			1
1550	1536.2	1563.8		1	1	1		1				1
1562.5	1548.7	1576.3	1	1	1	1		1				1
1575	1561.2	1588.8			1		1			1	1	
1587.5	1573.7	1601.3	1		1		1			1	1	
<b>1600</b>	1586.2	1613.8			1		1	1		2		
1612.5	1598.7	1626.3	1		1		1	1		2		
1625	1611.2	1638.8			1				2		1	
1637.5	1623.7	1651.3	1		1				2		1	
1650	1636.2	1663.8			1						2	
1662.5	1648.7	1676.3	1		1						2	
1675	1661.2	1688.8		1	1						2	
1687.5	1673.7	1701.3	1	1	1						2	
<b>1700</b>	1686.2	1713.8		1	1			1		1	1	
1712.5	1698.7	1726.3	1	1	1			1		1	1	
1725	1711.2	1738.8		1	1	1	1	1				1
1737.5	1723.7	1751.3	1	1	1	1	1	1				1
1750	1736.2	1763.8			1	2			1			1
1762.5	1748.7	1776.3	1		1	2			1			1
1775	1761.2	1788.8			1	1					2	
1787.5	1773.7	1801.3	1		1	1					2	
<b>1800</b>	1786.2	1813.8		1	1	1					2	
1812.5	1798.7	1826.3	1	1	1	1					2	
1825	1811.2	1838.8			1		1				2	
1837.5	1823.7	1851.3	1		1		1				2	
1850	1836.2	1863.8		1	1		1			1		1
1862.5	1848.7	1876.3	1	1	1		1			1		1
1875	1861.2	1888.8			1				2			1
1887.5	1873.7	1901.3	1		1				2			1
<b>1900</b>	1886.2	1913.8			1						1	1
1912.5	1898.7	1926.3	1		1						1	1
1925	1911.2	1938.8		1	1						1	1
1937.5	1923.7	1951.3	1	1	1						1	1
1950	1936.2	1963.8		2	1						1	1
1962.5	1948.7	1976.3	1	2	1						1	1
1975	1961.2	1988.8		1	1	1	1			1		1
1987.5	1973.7	2001.3	1	1	1	1	1			1		1

Tab. F6.01

For lowering, a remaining distance for the spindle of approx. 8 cm is to be planned.

# F7 Combination table 2,000 – 2,987.5 cm



Height			Height compensation		Head spindle	Modules						
h <sub>nom</sub>	min	max	12.5	25	100	125	175	275	375	525	775	1025
					±13.8 cm							
<b>2000</b>	1986.2	2013.8			1	1			2			1
2012.5	1998.7	2026.3	1		1	1			2			1
2025	2011.2	2038.8			1				1		2	
2037.5	2023.7	2051.3	1		1				1		2	
2050	2036.2	2063.8		1	1	1					1	1
2062.5	2048.7	2076.3	1	1	1	1					1	1
2075	2061.2	2088.8			1		1				1	1
2087.5	2073.7	2101.3	1		1		1				1	1
<b>2100</b>	2086.2	2113.8		1	1		1				1	1
2112.5	2098.7	2126.3	1	1	1		1				1	1
2125	2111.2	2138.8		1	1		1			2	1	
2137.5	2123.7	2151.3	1	1	1		1			2	1	
2150	2136.2	2163.8			1							2
2162.5	2148.7	2176.3	1		1							2
2175	2161.2	2188.8		1	1							2
2187.5	2173.7	2201.3	1	1	1							2
<b>2200</b>	2186.2	2213.8		1	1					2		1
2212.5	2198.7	2226.3	1	1	1					2		1
2225	2211.2	2238.8		1	1			2		1		1
2237.5	2223.7	2251.3	1	1	1			2		1		1
2250	2236.2	2263.8			1				3			1
2262.5	2248.7	2276.3	1		1				3			1
2275	2261.2	2288.8			1				1		1	1
2287.5	2273.7	2301.3	1		1				1		1	1
<b>2300</b>	2286.2	2313.8			1	1				1	2	
2312.5	2298.7	2326.3	1		1	1				1	2	
2325	2311.2	2338.8			1		1					2
2337.5	2323.7	2351.3	1		1		1					2
2350	2336.2	2363.8		1	1		1					2
2362.5	2348.7	2376.3	1	1	1		1					2
2375	2361.2	2388.8		1	1		1	1			1	1
2387.5	2373.7	2401.3	1	1	1		1	1			1	1
<b>2400</b>	2386.2	2413.8			1				2		2	
2412.5	2398.7	2426.3	1		1				2		2	
2425	2411.2	2438.8			1					1	1	1
2437.5	2423.7	2451.3	1		1					1	1	1
2450	2436.2	2463.8		1	1					1	1	1
2462.5	2448.7	2476.3	1	1	1					1	1	1
2475	2461.2	2488.8		1	1		1		1		1	1
2487.5	2473.7	2501.3	1	1	1		1		1		1	1
<b>2500</b>	2486.2	2513.8			1		2					2
2512.5	2498.7	2526.3	1		1		2					2

# F7 Combination table 2,000 – 2,987.5 cm

Height			Height compensation		Head spindle	Modules						
h <sub>nom</sub>	min	max	12.5	25	100	125	175	275	375	525	775	1025
					±13.8 cm							
2525	2511.2	2538.8			1				1			2
2537.5	2523.7	2551.3	1		1				1			2
2550	2536.2	2563.8		1	1				1			2
2562.5	2548.7	2576.3	1	1	1				1			2
2575	2561.2	2588.8		1	1	1		1				2
2587.5	2573.7	2601.3	1	1	1	1		1				2
<b>2600</b>	2586.2	2613.8			1		1			1	1	1
2612.5	2598.7	2626.3	1		1		1			1	1	1
2625	2611.2	2638.8			1		1	1		1	2	
2637.5	2623.7	2651.3	1		1		1	1		1	2	
2650	2636.2	2663.8			1				2		1	1
2662.5	2648.7	2676.3	1		1				2		1	1
2675	2661.2	2688.8			1						2	1
2687.5	2673.7	2701.3	1		1						2	1
<b>2700</b>	2686.2	2713.8		1	1						2	1
2712.5	2698.7	2726.3	1	1	1						2	1
2725	2711.2	2738.8		1	1			1		1	1	1
2737.5	2723.7	2751.3	1	1	1			1		1	1	1
2750	2736.2	2763.8		1	1	1	1	1				2
2762.5	2748.7	2776.3	1	1	1	1	1	1				2
2775	2761.2	2788.8			1				3		2	
2787.5	2773.7	2801.3	1		1				3		2	
<b>2800</b>	2786.2	2813.8			1	1					2	1
2812.5	2798.7	2826.3	1		1	1					2	1
2825	2811.2	2838.8		1	1	1					2	1
2837.5	2823.7	2851.3	1	1	1	1					2	1
2850	2836.2	2863.8			1		1			1		2
2862.5	2848.7	2876.3	1		1		1			1		2
2875	2861.2	2888.8		1	1		1			1		2
2887.5	2873.7	2901.3	1	1	1		1			1		2
<b>2900</b>	2886.2	2913.8			1				2			2
2912.5	2898.7	2926.3	1		1				2			2
2925	2911.2	2938.8			1						1	2
2937.5	2923.7	2951.3	1		1						1	2
2950	2936.2	2963.8			1					1	3	
2962.5	2948.7	2976.3	1		1					1	3	
2975	2961.2	2988.8		1	1			1		1		2
2987.5	2973.7	3001.3	1	1	1			1		1		2

Tab. F701

For lowering, a remaining distance for the spindle of approx. 8 cm is to be planned.

# F8 Combination table 3,000 – 4,000 cm



Height			Height compensation		Head spindle	Modules						
h <sub>nom</sub>	min	max	12.5	25	100	125	175	275	375	525	775	1025
					±13.8 cm							
<b>3000</b>	2986.2	3013.8		1	1	1	1			1		2
3012.5	2998.7	3026.3	1	1	1	1	1			1		2
3025	3011.2	3038.8			1	1			2			2
3037.5	3023.7	3051.3	1		1	1			2			2
3050	3036.2	3063.8			1				1		2	1
3062.5	3048.7	3076.3	1		1				1		2	1
3075	3061.2	3088.8		1	1	1					1	2
3087.5	3073.7	3101.3	1	1	1	1					1	2
<b>3100</b>	3086.2	3113.8			1		1				1	2
3112.5	3098.7	3126.3	1		1		1				1	2
3125	3111.2	3138.8		1	1		1				1	2
3137.5	3123.7	3151.3	1	1	1		1				1	2
3150	3136.2	3163.8		1	1		1			2	1	1
3162.5	3148.7	3176.3	1	1	1		1			2	1	1
3175	3161.2	3188.8			1							3
3187.5	3173.7	3201.3	1		1							3
<b>3200</b>	3186.2	3213.8		1	1							3
3212.5	3198.7	3226.3	1	1	1							3
3225	3211.2	3238.8		1	1					2		2
3237.5	3223.7	3251.3	1	1	1					2		2
3250	3236.2	3263.8		1	1			2		1		2
3262.5	3248.7	3276.3	1	1	1			2		1		2
3275	3261.2	3288.8			1				3			2
3287.5	3273.7	3301.3	1		1				3			2
<b>3300</b>	3286.2	3313.8			1				1		1	2
3312.5	3298.7	3326.3	1		1				1		1	2
3325	3311.2	3338.8			1				1	1	3	
3337.5	3323.7	3351.3	1		1				1	1	3	
3350	3336.2	3363.8			1		1					3
3362.5	3348.7	3376.3	1		1		1					3
3375	3361.2	3388.8		1	1		1					3
3387.5	3373.7	3401.3	1	1	1		1					3
<b>3400</b>	3386.2	3413.8		1	1		1	1			1	2
3412.5	3398.7	3426.3	1	1	1		1	1			1	2
3425	3411.2	3438.8			1				2		2	1
3437.5	3423.7	3451.3	1		1				2		2	1
3450	3436.2	3463.8			1					1	1	2
3462.5	3448.7	3476.3	1		1					1	1	2
3475	3461.2	3488.8		1	1					1	1	2
3487.5	3473.7	3501.3	1	1	1					1	1	2
<b>3500</b>	3486.2	3513.8			1			2		1	3	
3512.5	3498.7	3526.3	1		1			2		1	3	

# F8 Combination table 3,000 – 4,000 cm

Height			Height compensation		Head spindle	Modules						
h <sub>nom</sub>	min	max	12.5	25	100	125	175	275	375	525	775	1025
					±13.8 cm							
3525	3511.2	3538.8			1		2					3
3537.5	3523.7	3551.3	1		1		2					3
3550	3536.2	3563.8			1				1			3
3562.5	3548.7	3576.3	1		1				1			3
3575	3561.2	3588.8		1	1				1			3
3587.5	3573.7	3601.3	1	1	1				1			3
<b>3600</b>	3586.2	3613.8			1				1	3	2	
3612.5	3598.7	3626.3	1		1				1	3	2	
3625	3611.2	3638.8			1		1			1	1	2
3637.5	3623.7	3651.3	1		1		1			1	1	2
3650	3636.2	3663.8			1		1			2	3	
3662.5	3648.7	3676.3	1		1		1			2	3	
3675	3661.2	3688.8			1				2		1	2
3687.5	3673.7	3701.3	1		1				2		1	2
<b>3700</b>	3686.2	3713.8			1						2	2
3712.5	3698.7	3726.3	1		1						2	2
3725	3711.2	3738.8		1	1						2	2
3737.5	3723.7	3751.3	1	1	1						2	2
3750	3736.2	3763.8		1	1			1		1	1	2
3762.5	3748.7	3776.3	1	1	1			1		1	1	2
3775	3761.2	3788.8			1	1	1			2	3	
3787.5	3773.7	3801.3	1		1	1	1			2	3	
<b>3800</b>	3786.2	3813.8			1				3		2	1
3812.5	3798.7	3826.3	1		1				3		2	1
3825	3811.2	3838.8			1				1		3	1
3837.5	3823.7	3851.3	1		1				1		3	1
3850	3836.2	3863.8		1	1	1					2	2
3862.5	3848.7	3876.3	1	1	1	1					2	2
3875	3861.2	3888.8			1		1				2	2
3887.5	3873.7	3901.3	1		1		1				2	2
<b>3900</b>	3886.2	3913.8		1	1		1			1		3
3912.5	3898.7	3926.3	1	1	1		1			1		3
3925	3911.2	3938.8			1				2			3
3937.5	3923.7	3951.3	1		1				2			3
3950	3936.2	3963.8			1						1	3
3962.5	3948.7	3976.3	1		1						1	3
3975	3961.2	3988.8			1					1	3	1
3987.5	3973.7	4001.3	1		1					1	3	1
<b>4000</b>	3986.2	4013.8			1					3	3	

Tab. F8.01

For lowering, a remaining distance for the spindle of approx. 8 cm is to be planned.

Art. no.	Weight kg
117465	172.000

## Head spindle VST 100

As head spindle for the VARIOKIT Heavy-Duty Shoring Tower. As an option, can be used with the hydraulic device.

## Technical data

Permissible load-bearing capacity 70 t.

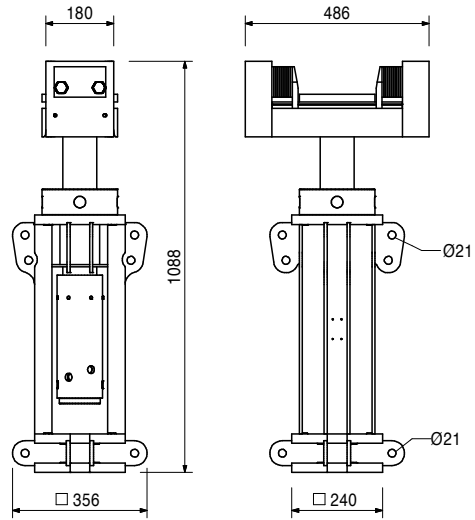
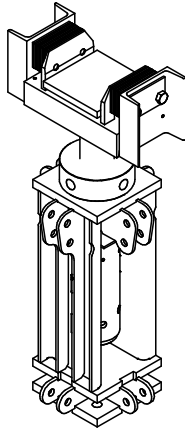

### Accessories

117377	1.030
117678	17.400

**Mounting shaft VST**  
**Hydraulic unit VST**

117454	48.200
--------	--------

## Prop connector VST 48

For connecting climbing rails RCS with the head spindle VST or the height compensation VST.

## Complete with

- 3 pc. 114563 bolt ISO 4014 M24 x 140-10.9
- 3 pc. 105032 nut ISO 7040 M24-8, galv.
- 3 pc. 117452 bolt ISO 4014 M20 x 130-10.9
- 3 pc. 781053 nut ISO 7040 M20-8, galv.
- 4 pc. 105416 bolt ISO 4014 M24 x 80-8.8, galv.

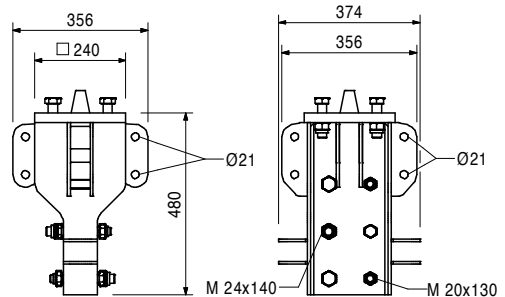
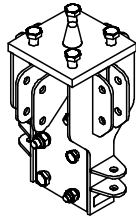

117453	45.500
--------	--------

## Prop base VST 48

As a prop base for VARIOKIT Heavy-Duty Shoring Tower with connection for climbing rails RCS.

## Complete with

- 3 pc. 114563 bolt ISO 4014 M24 x 140-10.9
- 3 pc. 105032 nut ISO 7040 M24-8, galv.
- 3 pc. 117452 bolt ISO 4014 M20 x 130-10.9
- 3 pc. 781053 nut ISO 7040 M20-8, galv.

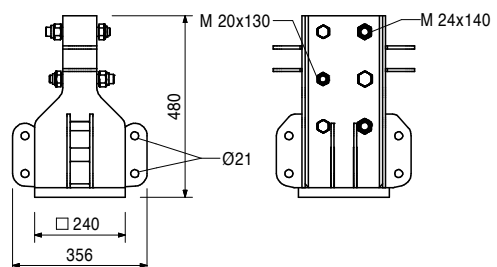
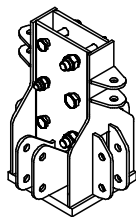



# VST Heavy-Duty Shoring Tower

Art. no.	Weight kg
117391	35.400

**Height compensation VST 25**  
As 25 cm height compensation.

**Complete with**  
4 pc. 105416 bolt ISO 4014 M24 x 80-8.8, galv.  
4 pc. 105032 nut ISO 7040 M24-8, galv.

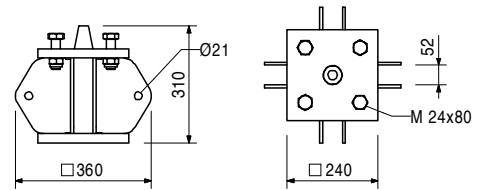
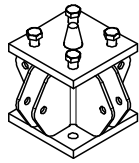

117433	28.900
--------	--------

**Height compensation VST 12.5**  
As 12.5 cm height compensation.

**Complete with**  
4 pc. 117429 threaded bolt VST M24, galv.  
8 pc. 105032 nut ISO 7040 M24-8, galv.

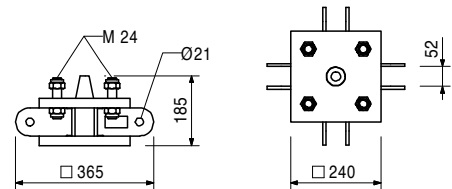
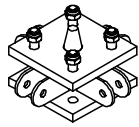

117425	7.090
--------	-------

**Cross connector VST**  
For connecting horizontal ledgers VST and diagonal struts VST perpendicular to the frame plane.

**Complete with**  
2 pc. 113994 bolt ISO 4014 M20 x 140-8.8, galv.  
2 pc. 781053 nut ISO 7040 M20-8, galv.  
1 pc. 117492 sleeve VST, galv.

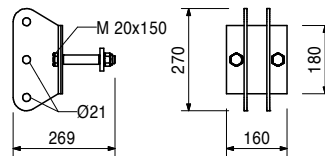
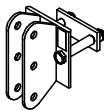

Art. no. 117411 Weight kg 18.600

### Bracing connector VST

For connecting horizontal ledgers VST and diagonal struts VST in frame plane.

### Complete with

- 2 pc. 104031 fitting pin  $\varnothing 21 \times 120$
- 2 pc. 111567 fitting pin  $\varnothing 26 \times 120$
- 2 pc. 018060 cotter pin 4/1, galv.
- 2 pc. 022230 cotter pin 5/1, galv.

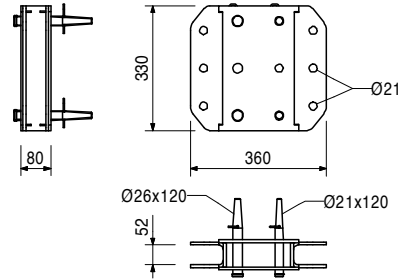
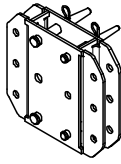

117371 31.400

### Horizontal ledger VST 200

As a horizontal ledger for the props. Produces a prop axis spacing of 2.00 m.

### Complete with

- 2 pc. 104031 fitting pin  $\varnothing 21 \times 120$
- 2 pc. 018060 cotter pin 4/1, galv.

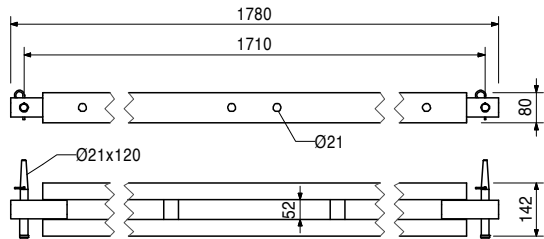
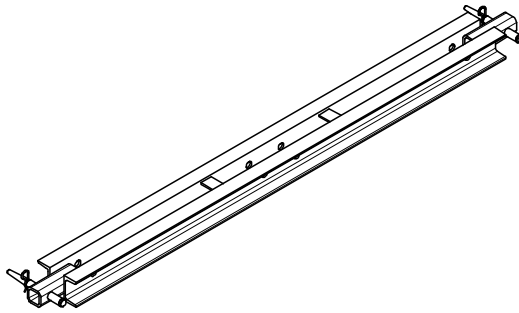

117504 21.700

### Horizontal brace VST 200/200

For horizontal stiffening of props.

### Complete with

- 2 pc. 105400 bolts  $\varnothing 20 \times 140$ , galv.
- 2 pc. 018060 cotter pin 4/1, galv.

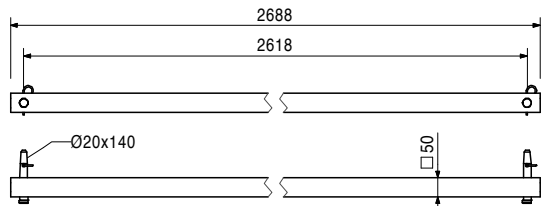
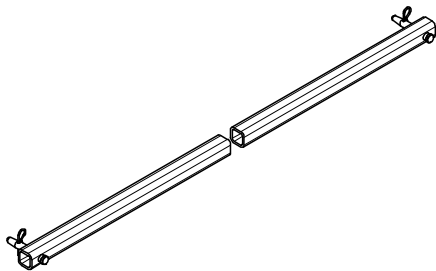

# VST Heavy-Duty Shoring Tower



Art. no.	Weight kg
117388	8.910
117382	10.900
117385	11.700
117379	14.100

**Diagonal struts VST**  
**Diagonal strut VST 200/62.5**  
**Diagonal strut VST 200/100**  
**Diagonal strut VST 200/112.5**  
**Diagonal strut VST 200/150**

L	X
1019	953
1271	1201
1367	1297
1680	1610

**Complete with**  
 2 pc. 104031 fitting pin  $\varnothing 21 \times 120$   
 2 pc. 018060 cotter pin 4/1, galv.

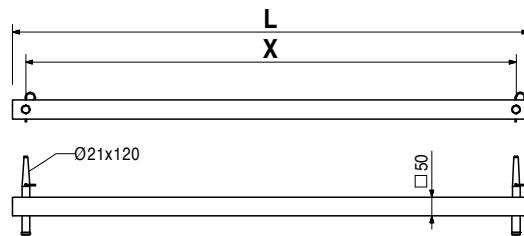
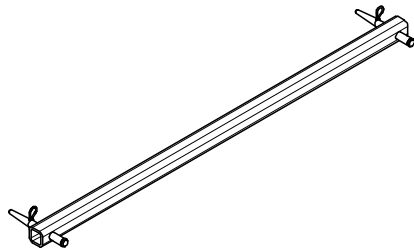

117696	2.130
--------	-------

**Horizontal connector VST**  
 For connecting additional legs to the standard frame. Leg distance 375 mm.

**Complete with**  
 2 pc. 104031 fitting pin  $\varnothing 21 \times 120$   
 2 pc. 018060 cotter pin 4/1, galv.

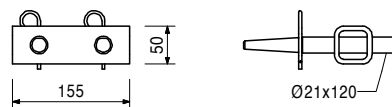
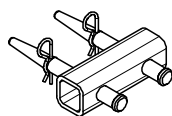

117712	35.700
--------	--------

**Additional connector VST**  
 For connecting additional legs to the standard frame. Leg distance 375 mm.

**Complete with**  
 4 pc. 104031 fitting pin  $\varnothing 21 \times 120$   
 4 pc. 018060 cotter pin 4/1, galv.

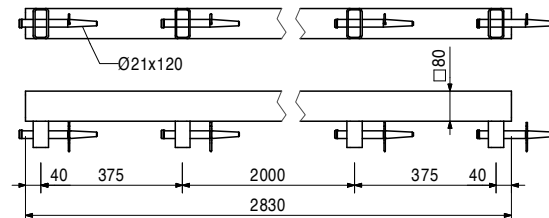
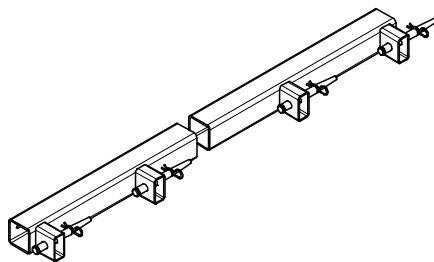

123823	4.160
--------	-------

**Adapter VST-SRU**  
 Adapter for connecting the SRU waler to the VARIOKIT Heavy-Duty Shoring Tower as a horizontal ledger.

**Complete with**  
 3 pc. 104031 fitting pin  $\varnothing 21 \times 120$   
 3 pc. 018060 cotter pin 4/1, galv.

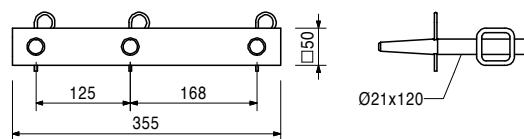
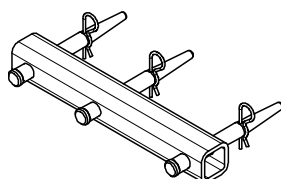

# VST Heavy-Duty Shoring Tower

Art. no.	Weight kg
117707	9.200

## Connector UP-VST

Adapter for attaching PERI UP scaffolding components to the VARIOKIT Heavy-Duty Shoring Tower.

## Complete with

- 1 pc. 104031 fitting pin  $\varnothing$  21 x 120
- 2 pc. 105400 bolts  $\varnothing$  20 x 140, galv.
- 3 pc. 018060 cotter pin 4/1, galv.
- 2 pc. 117701 connecting lug GEP.
- 1 pc. 024250 wedge K, galv.

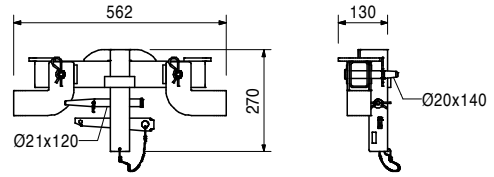
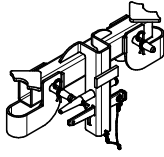

117377	1.030
--------	-------

## Mounting shaft VST

For adjusting the head spindle VST 100.

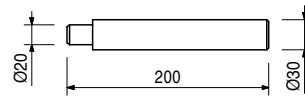
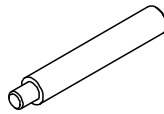

117678	17.400
--------	--------

## Hydraulic unit VST

Flexible hydraulic unit for use in the head spindle VST 100.

## Note

Observe Instructions for Use!

## Technical data

Lifting height 16 mm.

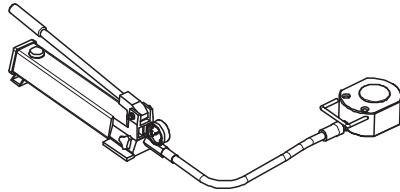

# VST Heavy-Duty Shoring Tower

Art. no.	Weight kg		L
103868	18.100	Steel waler universal SRU	722
103871	24.200	Steel waler universal SRU U120, L = 0.72 m	972
103874	30.900	Steel waler universal SRU U120, L = 0.97 m	1222
103877	38.100	Steel waler universal SRU U120, L = 1.22 m	1472
103886	44.700	Steel waler universal SRU U120, L = 1.47 m	1722
103889	52.000	Steel waler universal SRU U120, L = 1.97 m	1972
103898	58.600	Steel waler universal SRU U120, L = 2.22 m	2222
103892	65.600	Steel waler universal SRU U120, L = 2.47 m	2472
103929	72.000	Steel waler universal SRU U120, L = 2.72 m	2722
103903	81.000	Steel waler universal SRU U120, L = 2.97 m	2972
103906	92.600	Steel waler universal SRU U120, L = 3.47 m	3472
103915	106.000	Steel waler universal SRU U120, L = 3.97 m	3972
103918	119.000	Steel waler universal SRU U120, L = 4.47 m	4472
103922	135.000	Steel waler universal SRU U120, L = 4.97 m	4972
103925	146.000	Steel waler universal SRU U120, L = 5.47 m	5472
103928	159.000	Steel waler universal SRU U120, L = 5.97 m	5972

Universal steel waler profile U120 used as waling for girder wall formwork and for diverse special applications. With adjustable spacers.

**Note**  
See PERI Design Tables for permissible load!

**Technical data**  
U120:  $W_y = 121.4 \text{ cm}^3$ ,  $I_y = 728 \text{ cm}^4$ .

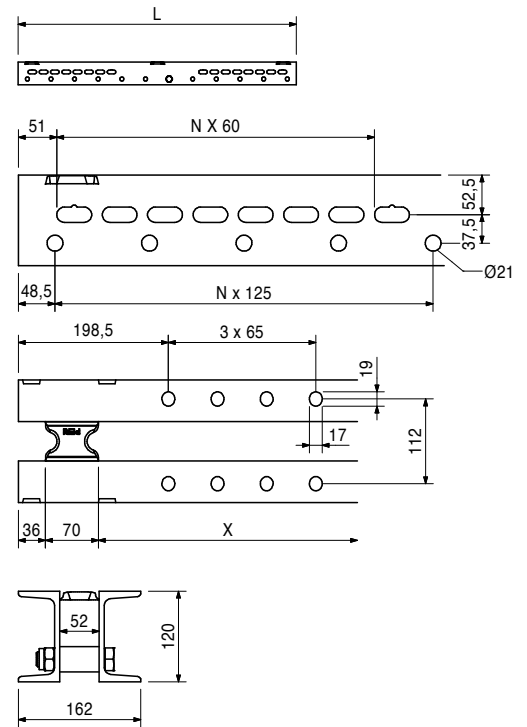
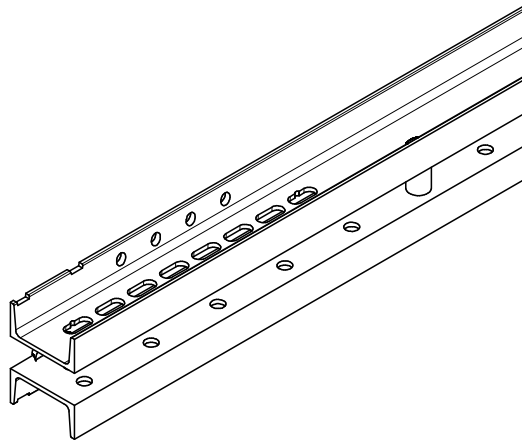

Art. no.	Weight kg		
104027	7.610	<b>Extension VARIO 24 U120</b>	<b>Complete with</b>

For mounting on steel waler SRU.

- 4 pc. 710252 bolt ISO 4017 M16 x 50-8.8, galv.
- 4 pc. 104024 nut ISO 7040 M16-8, galv.
- 4 pc. 710880 washer DIN 434 18, galv.

**Technical data**  
U120:  $W_y = 121.4 \text{ cm}^3$ ,  $I_y = 728 \text{ cm}^4$ .

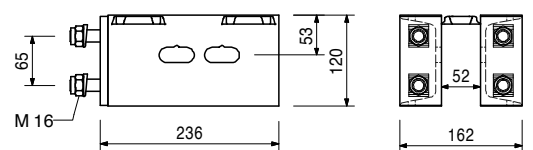
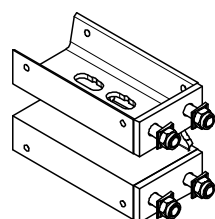

# VST Heavy-Duty Shoring Tower

Art. no.	Weight kg		L
114166	78.200	<b>Climbing rails RCS</b>	1480
109610	524.000	<b>Climbing rail RCS 148</b>	9980
109472	393.000	<b>Climbing rail RCS 998</b>	7480
109471	262.000	<b>Climbing rail RCS 748</b>	4980
109470	182.000	<b>Climbing rail RCS 498</b>	3480
109469	130.000	<b>Climbing rail RCS 348</b>	2480
112102	156.000	<b>Climbing rail RCS 248</b>	2980
112141	209.000	<b>Climbing rail RCS 398</b>	3980

Steel profile for all-purpose use for climbing applications or civil constructions. With spacers M20-82 and M24-82.

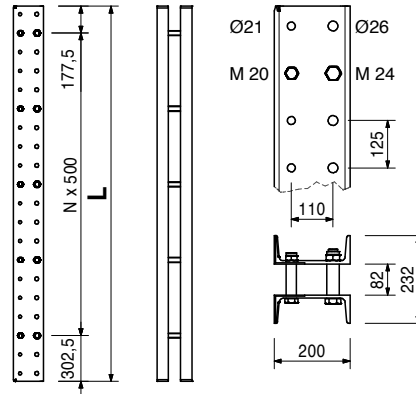

110022 0.491

## Spacer M20-82

Spacer for climbing rails RCS.

## Complete with

1 pc. 104477 bolt ISO 4014 M20 x 120-8.8, galv.  
1 pc. 130341 nut ISO 7042 M20-8, galv.

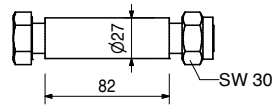
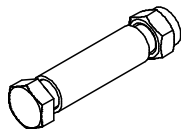

110023 0.910

## Spacer M24-82

Spacer for climbing rails RCS.

## Complete with

1 pc. 109612 bolt ISO 4014 M24 x 130-8.8, galv.  
1 pc. 130342 nut ISO 7042 M24-8, galv.

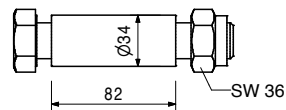
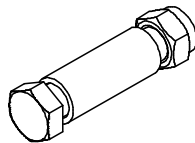

# VST Heavy-Duty Shoring Tower

Art. no.	Weight kg
111035	12.100
101773	14.700
101774	18.200
101776	24.700
101778	32.100
101779	38.300
109726	44.600
109785	50.800

- Heavy-duty spindles SLS**  
**Heavy-duty spindle SLS 40/80**  
**Heavy-duty spindle SLS 80/140**  
**Heavy-duty spindle SLS 100/180**  
**Heavy-duty spindle SLS 140/240**  
**Heavy-duty spindle SLS 200/300**  
**Heavy-duty spindle SLS 260/360**  
**Heavy-duty spindle SLS 320/420**  
**Heavy-duty spindle SLS 380/480**

Used as adjustable spindle for truss beams made of steel walers SRU and climbing rails RCS.

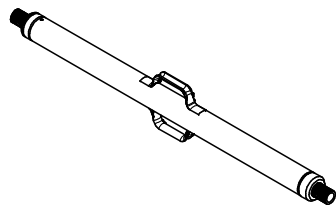

A	min. L	max. L
344	400	800
746	800	1400
946	1000	1800
1346	1400	2400
1944	2000	3000
2544	2600	3600
3144	3200	4200
3744	3800	4800

**Note**

See PERI Design Tables for permissible load.

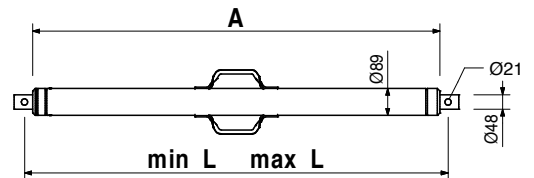

104031	0.462
018060	0.030
110477	3.990

- Accessories  
**Fitting pin Ø 21 x 120**  
**Cotter pin 4/1, galv.**  
**Spindle adapter SLS/RCS**

110477	3.990
--------	-------

- Spindle adapter SLS/RCS**  
 For connecting heavy-duty spindles SLS to the climbing rail RCS.

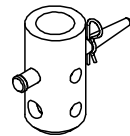

**Complete with**

- 1 pc. 104031 fitting pin Ø 21 x 120  
 1 pc. 018060 cotter pin 4/1, galv.

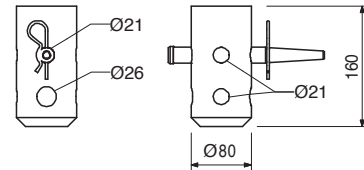

104031	0.462
018060	0.030
111567	0.729
022230	0.033

- Accessories  
**Fitting pin Ø 21 x 120**  
**Cotter pin 4/1, galv.**  
**Fitting pin Ø 26 x 120**  
**Cotter pin 5/1, galv.**

104031	0.462
--------	-------

- Fitting pin Ø 21 x 120**  
 For diverse connections.

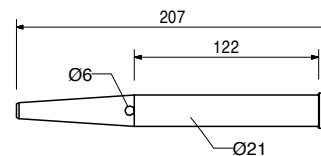
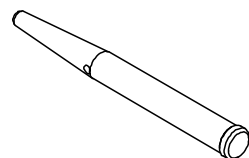

018060	0.030
--------	-------

- Accessories  
**Cotter pin 4/1, galv.**

# VST Heavy-Duty Shoring Tower

Art. no.	Weight kg	
018060	0.030	<b>Cotter pin 4/1, galv.</b>



Art. no.	Weight kg		L
105416	0.360	<b>Bolts ISO 4014-8.8, galv.</b>	80
113994	0.421	<b>Bolt ISO 4014 M24 x 80-8.8, galv.</b>	140
		<b>Bolt ISO 4014 M20 x 140-8.8, galv.</b>	

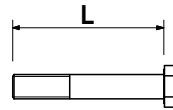
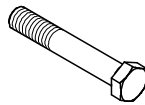

Art. no.	Weight kg		L
117452	0.360	<b>Bolts ISO 4014-10.9, galv.</b>	130
114563	0.627	<b>Bolt ISO 4014 M20 x 130-10.9</b>	140
		<b>Bolt ISO 4014 M24 x 140-10.9</b>	

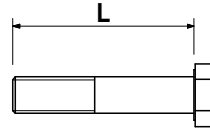
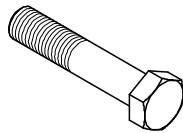

118256	0.020	<b>Cyl. Bolt ISO 4762 M20 x 150-8.8, galv.</b>
--------	-------	--

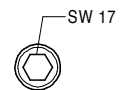
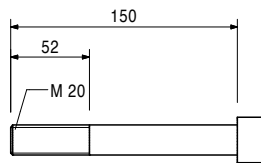
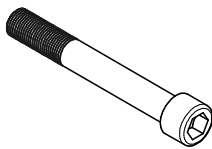

781053	0.065	<b>Nut ISO 7040 M20-8, galv.</b> Self-locking.
--------	-------	---





# VST Heavy-Duty Shoring Tower

Art. no.	Weight kg	
105032	0.070	<b>Nut ISO 7040 M24-8, galv.</b> Self-locking.

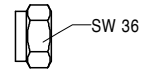

117492	0.109	<b>Sleeve VST, galv.</b>
--------	-------	--------------------------

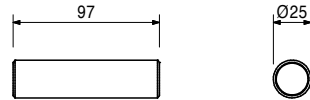
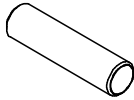

105400	0.330	<b>Pin Ø 20 x 140, galv.</b> For diverse connections.
--------	-------	--

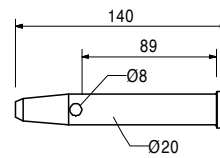
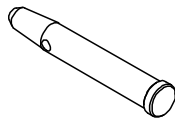

Accessories

018060	0.030	<b>Cotter pin 4/1, galv.</b>
--------	-------	------------------------------

024250	0.331	<b>Wedge K, galv.</b> For coupling compression plate KDP, wedge head piece SRZ/SRU and waler connector SB-A, B, C.
--------	-------	---

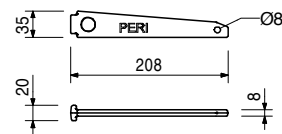

# VST Heavy-Duty Shoring Tower

Art. no.	Weight kg
102860	7.690
100012	14.700

**Standards UVR**  
**Vertical leg UVR 150**  
**Vertical leg UVR 300**

**L**  
 1500  
 3000

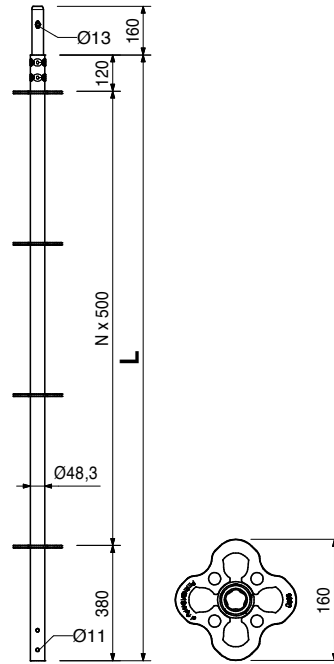
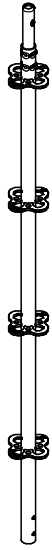

100021	4.690
--------	-------

**Ledger UH 150**

**Note**  
 From 01.07.2009, available only as rentable item.

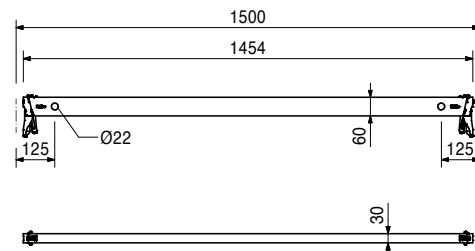
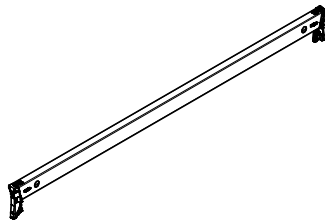

030030	1.440
030050	0.000

**Tie rod DW 15**  
**Tie rod DW 15, special length**  
**Cutting cost tie rod DW 15, B 15**

**Note**  
 Non-weldable! Observe the permissions!  
**Technical data**  
 Permissible tension force 90 kN.

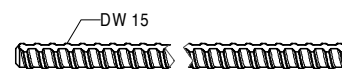
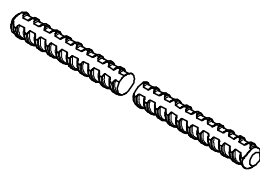

# VST Heavy-Duty Shoring Tower

Art. no.	Weight kg
030130	0.318

**Cam nut DW 15, galv.**  
For anchoring with tie rod DW 15 and B 15.

**Technical data**  
Permissible load 90 kN.

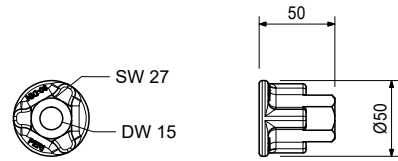
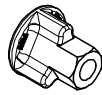

030370	1.660
--------	-------

**Wingnut pivot plate DW 15, galv.**  
For anchoring with tie rod DW 15 and B 15. With articulated, captive nut. Maximum inclination of anchor: 8°.

**Note**  
Wrench size SW 27.  
**Technical data**  
Permissible load 90 kN.

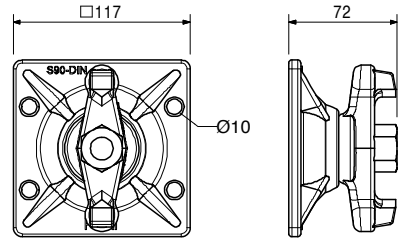
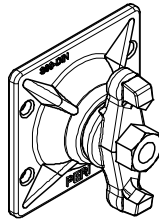

030340	4.480
030500	0.000

**Tie rod DW 26**  
**Tie rod DW 26, special length**  
**Cutting cost tie rod DW 26**

**Note**  
Non-weldable! Observe the permissions!  
**Technical data**  
Permissible tension force 250 kN.

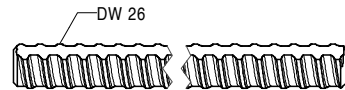
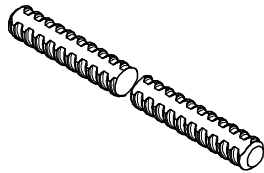

123825	1.130
--------	-------

**Counterplate DW 26**

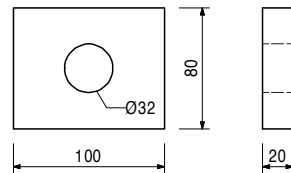
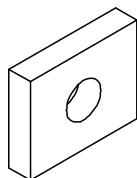

# VST Heavy-Duty Shoring Tower

Art. no.	Weight kg
030970	0.800

**Hex. coupler DW 26 SW 46/80, weldable**  
For anchoring with tie rod DW 26.

## Note

Weldable!

## Technical data

Permissible load 250 kN.

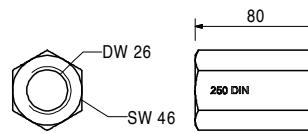
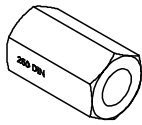





**PERI Norge AS**  
**Forskaling Stillas Engineering**  
Orhusveien 6  
3070 Sande i Vestfold  
Norge  
Tel. +47 32 20 49 40  
info@peri.no  
www.peri.no

