

VARIOKIT VCB Cantilever Bracket

Instructions for Assembly and Use – Standard Configuration

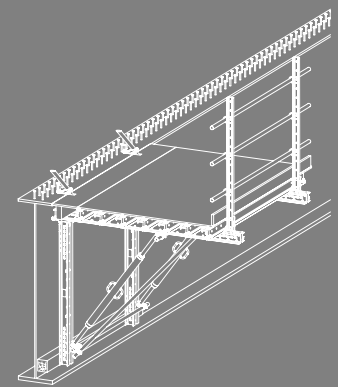

Overview

Main components	1
Key	2
Presentational reference	2

Introduction

Target groups	3
Additional technical documentation	3
Intended use	4
Instructions for Use	4
Care and maintenance instructions	5

Safety instructions

Cross-system	6
System-specific	7
Storage and transportation	7

Pre-assembly

A1	Views	8
A2	Load conditions	11
A3	Platform	
	Platform grid	12
	Guardrail Post RCS/SRU 184	13
	Waler Jack with Connector VARIOKIT	13
	Tie Rod DW 15	14
	Device Suspension Lock VCB DW 15	15
A4	Formwork	
	Planking	17
	Stopend formwork on the planking	18
A5	Guardrails	
	Rear guardrails with	
	Guardrail Post RCS/SRU 184	19
	Lateral guardrails with	
	Guardrail Post SCS 150	20
A6	Formwork unit	
	Preparation	21
	Horizontal Waler Jack with	
	Connector VARIOKIT	22
	Vertical Steel Waler SRU U120	23
	Formwork unit triangle	24
A7	Moving the cantilever bracket	
	Mounting timbers	26
	Lifting the cantilever bracket	26
A8	Anchor Bracket VARIOKIT	27

Assembly

B1	Positioning and fixing the cantilever bracket	
	Positioning the cantilever bracket	28
	Fixing the cantilever bracket	29
B2	Bottom sealing of the platform levels	30
B3	Removing the lifting fork	31
B4	Closing the planking	
	Filler plates	32
	Opening	32
B5	Top sealing of the suspension	33

Concreting

C1	Concreting	36
----	------------	----

Dismantling

D1	Breaking open the anchor points	37
D2	Removing the Plug Lock VCB DW 15	38
D3	Loosening and removing the cantilever bracket	39
D4	Dismantling the cantilever bracket	43

Components

	Cantilever Bracket VCB	46
--	------------------------	----

Main components/System assemblies

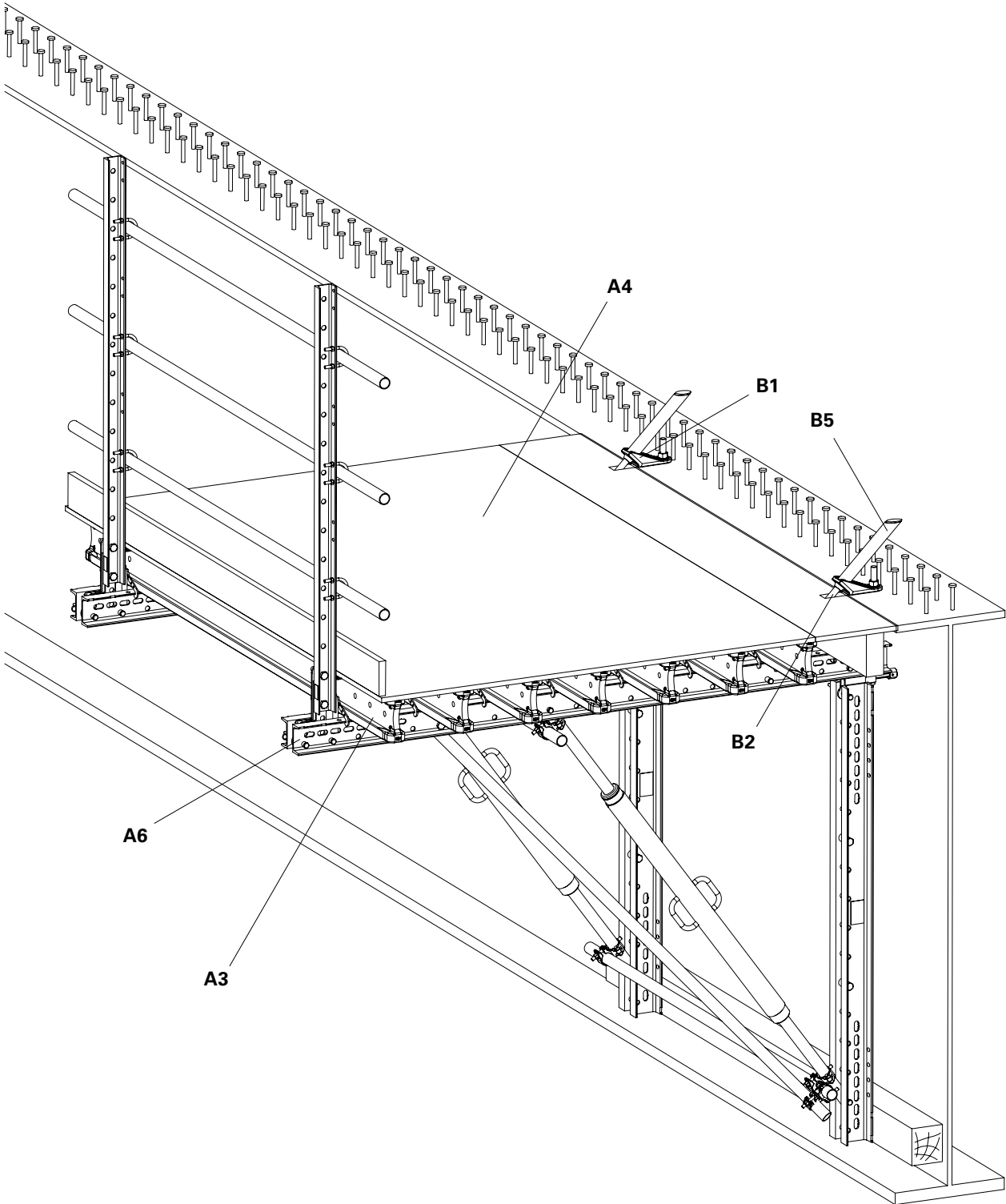

- A3 Platform
- A4 Formwork
- A6 Formwork unit
- B1 Fixing the cantilever bracket
- B2 Bottom sealing of the platform levels
- B5 Top sealing of the suspension

Key

Pictogram | Definition

 Safety instructions

 Note

 Visual check

 Tip

 Safety helmet

 Safety glasses

 Safety gloves

 Personal protective equipment to prevent falling from a height (PPE)

 Misapplication

Dimension specifications

Dimensions are usually given in mm. Other measurement units, e.g. cm, are shown in the illustrations.

Conventions

- Instructions are numbered with:
1. , 2. , 3.
- The result of an instruction is shown by: →
- Position numbers are clearly provided for the individual components and are given in the drawing, e.g. **1**, in the text in brackets, for example (1).
- Multiple position numbers, i.e. alternative components, are represented with a slash, e.g. **1 / 2**.

Arrows

 Arrow representing an action

 Arrow representing a reaction of an action*

* If not identical to the action arrow.

Presentational reference

The illustration on the front cover of these instructions is understood to be a system representation only. The assembly steps presented in these Instructions for Assembly and Use are shown in the form of examples with only one component size. They are valid accordingly for all component sizes contained in the standard configuration.

For a better understanding, detailed illustrations are partly incomplete. The safety installations which have possibly not been featured in these detailed drawings must nevertheless still be available.

Target groups

Contractors

These Instructions for Assembly and Use are designed for contractors who use the formwork systems for

- assembling, modifying and dismantling operations, or
- use them, e.g. for concreting, or
- for other operations, e.g. carpentry or electrical work.

Construction site coordinator

The Safety and Health Protection Coordinator*

- is appointed by the client,
- must identify potential hazards during the planning phase,
- determines measures that provide protection against risks,
- creates a safety and health plan,
- coordinates the protective measures for the contractor and site personnel so that they do not endanger each other,
- monitors compliance with the protective measures.

Competent persons

Due to the specialist knowledge gained from professional training, work experience and recent professional activity, the competent person has a reliable understanding of safety-related issues and can correctly carry out inspections. Depending on the complexity of the test to be undertaken, e.g. scope of testing, type of testing or the use of a certain measuring device, a range of specialist knowledge is necessary.

Qualified persons

Formwork systems may only be assembled, modified or dismantled by personnel who are suitably qualified to do so. For the work to be carried out, the qualified persons must have received instructions** which contain at least the following points:

- Explanation of the plan for the assembly, modification or dismantling of the formwork in an understandable form and language.
- Description of measures in order to safely assemble, modify or dismantle the formwork system.

- Designation of the preventive measures to avoid the risk of persons and objects falling.
- Designation of the safety precautions in the event of changing weather conditions which could adversely affect the safety of the formwork system concerned as well as the personnel.
- Details regarding the permissible loads.
- Description of any other risks that are associated with the assembly, modification or dismantling procedures.



- **In other countries, ensure that the relevant national guidelines and regulations in the respective current version are complied with!**
- **If no country-specific regulations are available, it is recommended to proceed according to German rules and regulations.**

* Valid in Germany: Regulations for Occupational Health and Safety on Construction Sites 30 (RAB 30).

** Instructions are given by the contractor himself or a competent person selected by him.

Additional technical documentation

- Instructions for Use:
 - Table Lifting Fork
- PERI Design Tables
 - Formwork and Shoring

Intended use

Product description

PERI products have been designed for exclusive use in the industrial and commercial sectors by qualified users only.

The PERI Cantilever Bracket is a flexible and safe system solution for forming cantilevers on steel composite and pre-cast concrete bridges.

All work operations such as platform anchoring, sealing, shuttering, reinforcement, striking as well as loosening and dismantling can be carried out from the top.

Concrete compaction is possible with this cantilever formwork during concreting and smoothing of the bridge superstructure slab with the help of a vibrating beam without encountering any obstacles.

Main components are standardized PERI components taken from the VARIOKIT Engineering Construction Kit.

The supporting structure of the platform features two parallel brackets consisting of SRU Steel Walers and SLS Spindles, which are selected and adjusted in accordance with the size and geometry of the cantilever as well as the bridge radius.

Both brackets are thereby connected by means of wind bracing and other reinforcement measures.

Instructions for Use

The use in a way not intended, deviating from the standard configuration or the intended use according to the Instructions for Assembly and Use, represents a misapplication with a potential safety risk, e.g. risk of falling.

Only PERI original components may be used. The use of other products and spare parts is not allowed.

Changes to PERI components are not permitted.

Features

The PERI Cantilever Bracket is a system which is positioned under the superstructure slab.

- No interference on and under the bridge through the formwork components.
- Directly accessible.

The PERI Cantilever Bracket consists of:

- Supporting structure
- Platform
- Formwork

Technical data

Maximum permissible load per anchoring point:

- 70 kN when using the "VARIOKIT Anchor Bracket"
- 50 kN during project-specific use of the "Tie Bracket 15" – not shown in the following.

The direction of the load transfer into the anchor bracket allows an angle deviation of $\pm 5^\circ$ – compare with design information for the Cantilever Bracket.

Care and maintenance instructions

In order to maintain the value and operational readiness of the formwork materials over the long term, clean the elements after each use. Some repair work may also be inevitable due to the tough working conditions.

The following points should help to keep care and maintenance costs as low as possible.

Spray the formwork on both sides with concrete release agent before each use; this allows easier and faster cleaning of the formwork. Spray the concrete release agent very thinly and evenly!

Spray the rear side of the formwork with water immediately after concreting; this avoids any time-consuming and costly cleaning operations.

When used continuously, spray the panel formlining with the concrete release agent immediately after striking; then clean by means of a scraper, brush or rubber lip scraper. Important: do not clean formlining made of plywood with high-pressure equipment; this could result in the formlining being damaged.

Fix box-outs recesses and mounting parts with double-headed nails; as a result, the nails can be easily removed later, and damage to the formlining is largely avoided.

Close all unused anchor holes with plugs; this eliminates any subsequent cleaning or repair work. Anchor holes accidentally blocked with concrete are freed by means of a steel pin from the formlining side.

When placing bundles of reinforcement bars or other heavy objects on horizontally-stored formwork elements, suitable support, e.g. square timbers, is to be used; as a result, impressions and damage to the formlining are largely avoided.

Internal concrete vibrators should be fitted with rubber caps if possible; as a result, any damage to the formlining is reduced if the vibrator is accidentally "inserted" between the reinforcement and formlining.

Never clean powder-coated components, e.g. elements and accessories, with a steel brush or hard metal scraper; this ensures that the powder coating remains intact.

Use spacers for reinforcement with large-sized supports or extensive areas of support; this largely avoids impressions being formed in the formlining when under load.

Mechanical components, e.g. spindles or gear mechanisms, must be cleaned of dirt or concrete residue before and after use, and then greased with a suitable lubricant.

Provide suitable support for the components during cleaning so that no unintentional change in their position is possible.

Do not clean components when suspended on a crane.

Cross-system

General

The contractor must ensure that the Instructions for Assembly and Use supplied by PERI are available at all times and are understood by the site personnel.

These Instructions for Assembly and Use can be used as the basis for creating a risk assessment. The risk assessment is compiled by the contractor. The Instructions for Assembly and Use do not replace the risk assessment!

Always take into consideration and comply with the safety instructions and permissible loads.

For the application and inspection of PERI products, the current safety regulations and guidelines must be observed in the respective countries where they are being used.

Materials and working areas are to be inspected on a regular basis especially before each use and assembly for:

- signs of damage,
- stability and
- function.

Damaged components must be exchanged immediately on site and may no longer be used.

Safety components are to be removed only when they are no longer required.

Components provided by the contractor must conform with the characteristics required in these Instructions for Assembly and Use as well as with all valid construction guidelines and standards. In particular, the following applies if nothing else is specified:

- Timber components: Strength Class C24 for Solid Wood according to EN 338.
- Scaffold tubes: galvanized steel tubes with minimum dimensions of Ø 48.3 x 3.2 mm according to EN 12811-1:2003 4.21.2.
- Scaffold tube couplings according to EN 74.

Deviations from the standard configuration are only permitted after a further risk assessment has been carried out by the contractor. On the basis of this risk assessment, appropriate measures for working and operational safety as well as stability are to be determined.

Corresponding proof of stability can be provided by PERI on request if the risk assessment and resulting measures to be implemented are made available.

Before and after exceptional occurrences that may have had an adverse effect regarding the safety of the formwork system, the contractor must immediately

- create another risk assessment, with appropriate measures for ensuring the stability of the formwork system being carried out based on the results,
- and arrange for an extraordinary inspection by a competent person. The aim of this inspection is to identify and rectify any damage in good time in order to guarantee the safe use of the formwork system.

Exceptional occurrences can include:

- accidents,
- longer periods of non-use,
- natural events, e.g. heavy rainfall, icing, heavy snowfall, storms or earthquakes.

Assembly, modification and dismantling work

Assembly, modification or dismantling of formwork systems may only be carried out by qualified persons under the supervision of a competent person. The qualified persons must have received appropriate training for the work to be carried out with regard to specific risks and dangers.

On the basis of the risk assessment and Instructions for Assembly and Use, the contractor must create installation instructions in order to ensure safe assembly, modification and dismantling of the formwork system.

The contractor must ensure that the personal protective equipment required for the assembly, modification or dismantling of the system, e.g.

- safety helmet,
 - safety shoes,
 - safety gloves,
 - safety glasses,
- is available and used as intended.

If personal protective equipment against falling (PPE) is required or specified in local regulations, the contractor must determine appropriate attachment points on the basis of the risk assessment.

The personal protective equipment against falling to be used is determined by the contractor.

The contractor must

- provide safe working areas for site personnel which are to be reached through the provision of safe access ways. Areas of risk must be cordoned off and clearly marked.
- ensure the stability during all stages of construction, in particular during assembly, modification and dismantling of the formwork.
- ensure and prove that all loads can be safely transferred.

Utilisation

Every contractor who uses or allows formwork systems or sections of the formwork to be used, has the responsibility for ensuring that the equipment is in good condition.

If the formwork system is used successively or at the same time by several contractors, the health and safety coordinator must point out any possible mutual hazards and all work must be then coordinated.

System-specific

Retract components only when the concrete has sufficiently hardened and the person in charge has given the go-ahead for striking to take place.

Anchoring is to take place only if the anchorage has sufficient concrete strength.

Working areas situated below must be protected by means of appropriate measures.

Tools and materials are to be secured to prevent them from falling to the ground. Concrete excess and other forms of dirt are to be removed.

Every cantilever bracket must be mounted together with two anchors. Platforms may be accessed only after bracing has been mounted.

When storing heavy items on the formwork, the maximum load-bearing capacity must be taken into consideration.

Damaged suspension components must not be used.

Examples of damage:

- welding spatter on the threaded rod
- bent components
- rough-running threads
- deformed anchor brackets and tube nuts
- buckled, deformed, bent Tie Rods DW 15

Storage and transportation

Store components ensuring that no unintentional change in their position is possible. Detach lifting accessories and slings from the lowered components only if they are in a stable position and no unintentional change is possible.

Do not drop the components.

Use PERI lifting accessories and slings as well as only those load-bearing points provided on the component.

During transport

- ensure that components are picked up and set down so that unintentional falling over, falling apart, sliding, falling down or rolling is avoided.
- no persons are allowed to remain under the suspended load.

The access areas on the jobsite must be free of obstacles and tripping hazards as well as being slip-resistant.

For transportation, the surface must have sufficient load-bearing capacity.

Use original PERI storage and transport systems, e.g. crate pallets, pallets or stacking devices.

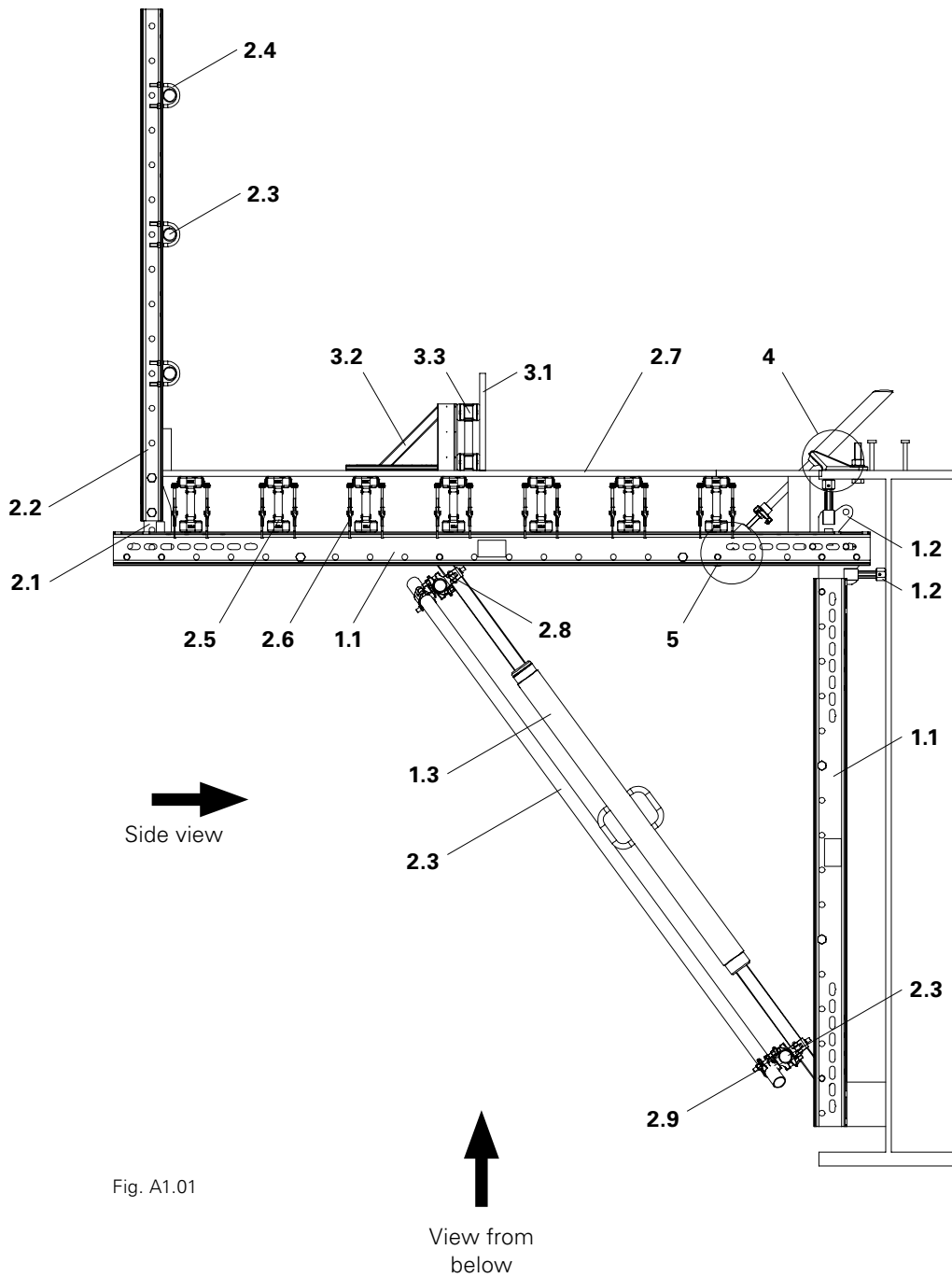

Fig. A1.01

Side view

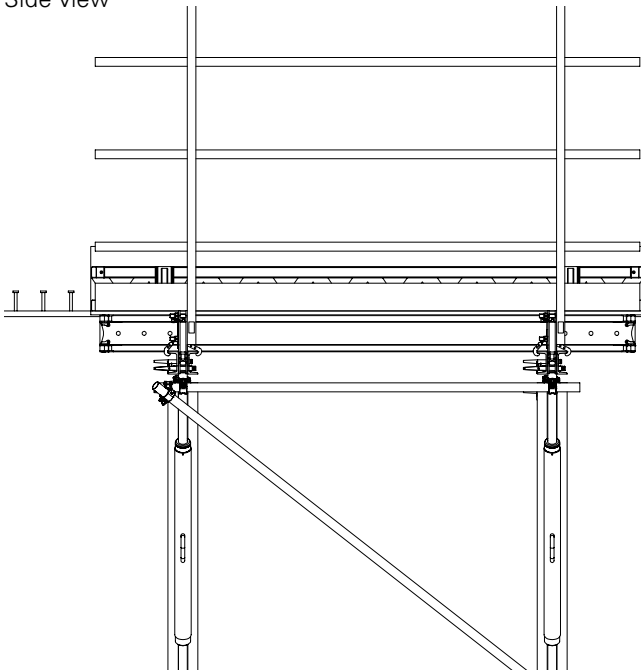

Fig. A1.02

View from below

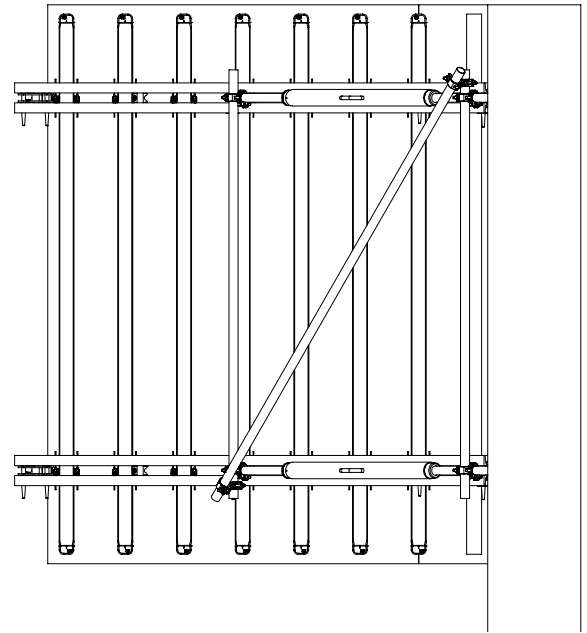

Fig. A1.03

1	Formwork unit	Item no.
1.1	Steel Waler SRU U120	
1.2	Waler Jack with Connector VARIOKIT	115616
1.3	Heavy-Duty Spindle SLS	
2	Platform	
2.1	Corner Connector SRU VARIOKIT	115623
2.2	Guardrail Post RCS/SRU 184	114328
2.3	Steel Scaffold Tube Ø 48.3 x 3.2	
2.4	Clamp A64 DIN 3570 M12, galv.	110296
2.5	Girder VT 20K	
2.6	Hook Strap Uni HBU 20-24	104931
2.7	Formlining (e.g. Finply 21 mm)	(052060)
2.8	Standard Coupling NK 48/48, galv.	017020
2.9	Swivel Coupling DK 48/48, galv.	017010
3	Formwork	
3.1	Formlining (e.g. Finply 21 mm)	(052270)
3.2	AW Slab Stopend Angle	065070
3.3	Girder VT 20K	
4	Suspension on the steel construction – see following pages	
5	Suspension on the formwork unit – see following pages	

Table
A1.01

Suspension on the steel construction

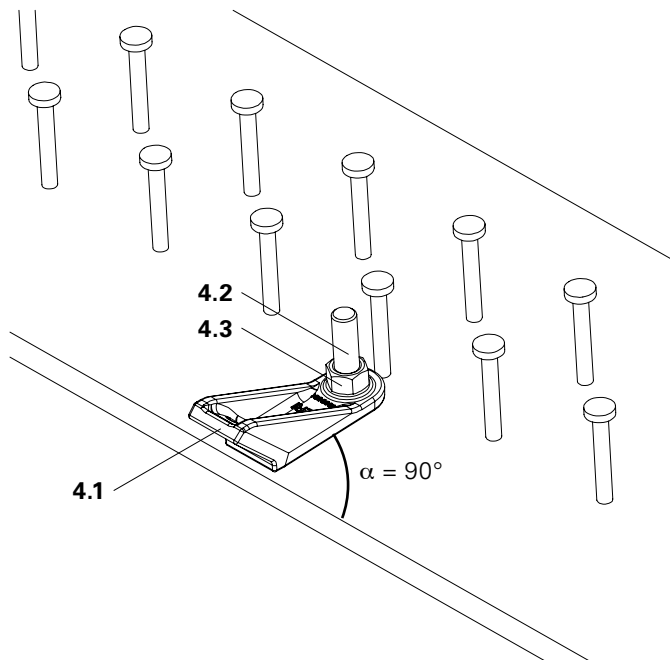

Fig. A1.04

Suspension on the formwork unit

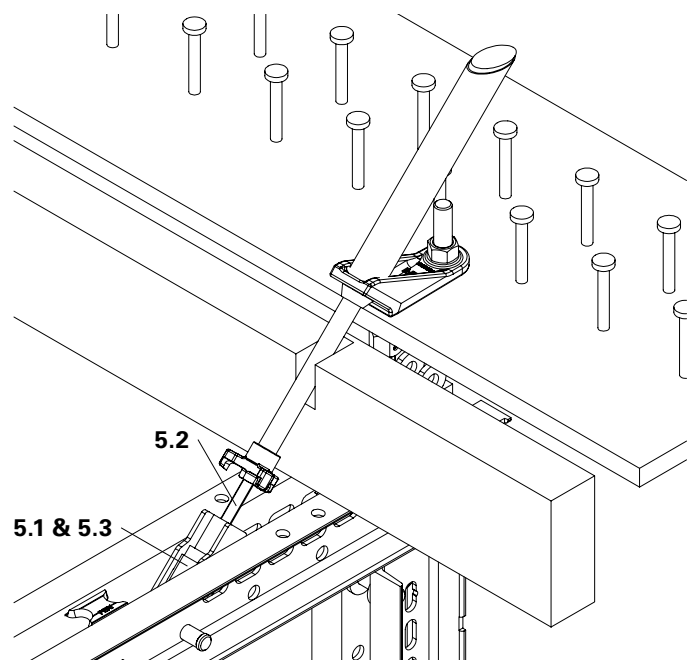

Fig. A1.05



Secure the Anchor Bracket VARIOKIT at right-angles to the front edge of the structural beam. This is required for inserting the Tie Rods DW 15.

4	Suspension on the steel construction – cf. Design Information for the Cantilever Bracket	Item no.
4.1	Anchor Bracket VARIOKIT	115808
4.2	Bolt ISO 4017 M24 x 100-10.9	706489
4.3	Nut ISO 4032-M24-10	706488
5	Suspension on formwork unit – cf. Design Information for the Cantilever Bracket	
5.1	Suspension Lock VCB DW 15	129754
5.2	Tie Rod DW 15	030010
5.3	Hex. Nut DW 15 SW 30/50, galv.	030070

Table A1.02

Load conditions when using the Cantilever Bracket VCB



- The standard values are to be considered as reference points and must be verified in each respective project.
- If necessary, place ballast on the cantilever bracket units in order to prevent tipping.

Work procedures

- Adjusting the formwork
- Installing reinforcement in the cantilevered parapet
- Closing the side formwork and concreting
- Striking
- Inspection and maintenance

Load Case: Working Operations	
Live load on the platform	2.00 kN/m ²
Working wind	0.20 kN/m ²

Table A2.01



Live loads and fresh concrete loads are transferred via tension rods into the steel sub-structure.

Load Case: Concreting	
Live load on the platform	0.75 kN/m ²
Working wind	0.20 kN/m ²

Table A2.02

Load Case: Storm
<ul style="list-style-type: none"> – Position, width of influence etc. must be determined individually for each project. – Possible countermeasures must be featured in the general arrangement drawings.

Table A2.03

Assembly area



We recommend preparing a flat assembly area.

- Stops positioned at right-angles simplify precise and fast pre-assembly of the cantilever brackets.
- Take into consideration extensions for the assembly trestle for assembling the formwork unit.
- More information can be provided by PERI on request.

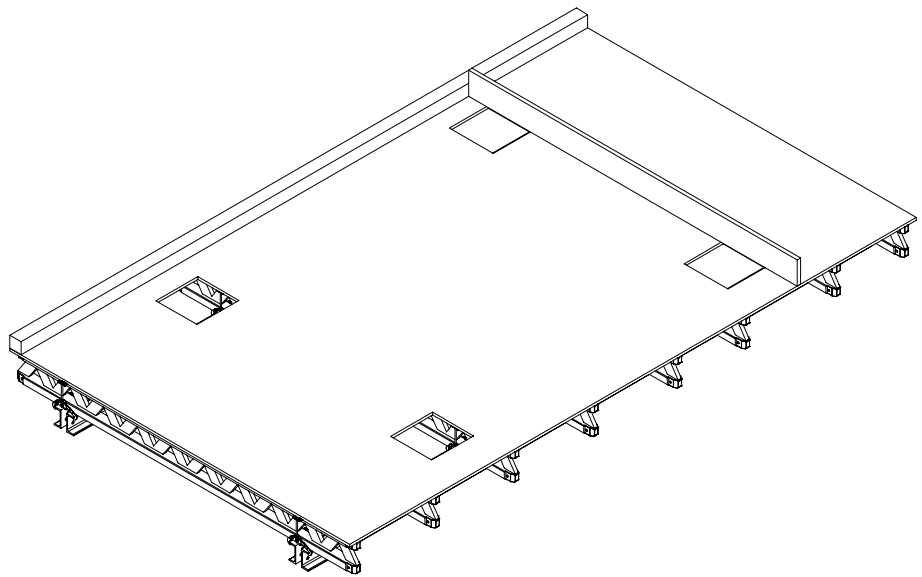

Fig. A3.01

Platform grid



- Use timbers for adapting to the structural beam and for the openings of the tie rod penetrations.
- The inclination of the opening is given in the project-specific drawings.
- The width of influence can be taken from the PERI general arrangement drawings.

Assembly

1. Position Steel Waler SRU U120 (1.1) according to the width of influence.
2. Mount Girder VT 20K (2.5) with 2x Hook Strap HBU (2.6) in each case. (Fig. A3.02a)
3. Mount timbers by means of hex. wood screws.

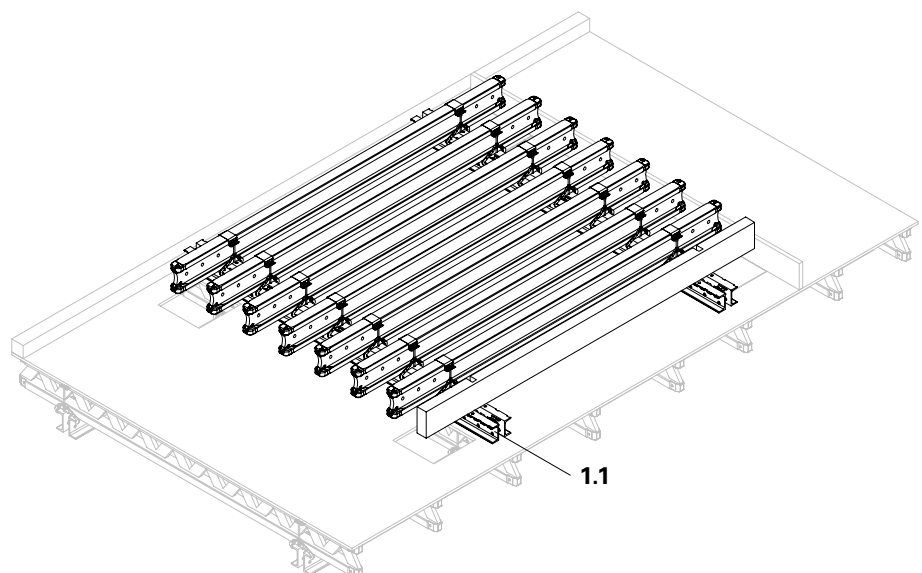

Fig. A3.02



Girder VT 20 or Girder GT 24 can also be used instead of Girder VT 20K.

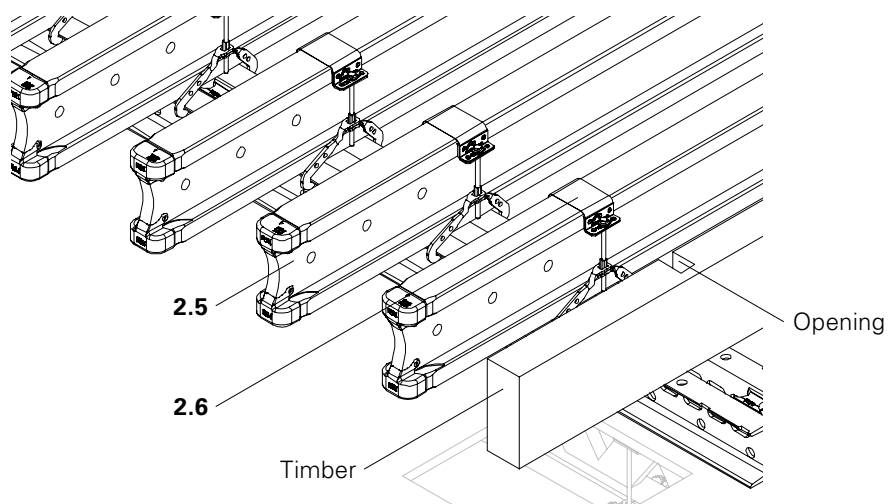

Fig. A3.02a

Guardrail Post RCS/SRU 184

Pos.	Designation	Pieces
2.1	Corner Connector SRU VARIOKIT	2x
2.2	Guardrail Post RCS/SRU 184	2x
1.4	Fitting Pins Ø 21 mm	4x
1.5	Bolt ISO 4014 M20 x 100	4x
	Nut ISO 4032 M20	4x

Assembly

1. Mount Corner Connector SRU VARIOKIT (2.1) onto the Steel Waler SRU U120 (1.1) using 2x Fitting Pins Ø 21 mm (1.4), and secure with cotter pins 4/1, galv. (Fig. A3.03a)
2. Mount Guardrail Post RCS/SRU 184 (2.2) onto the Corner Connector VARIOKIT (2.1) using 2x Bolts ISO 4014 M20 x 100 and Nuts ISO 4032 M20. (Fig. A3.03a)

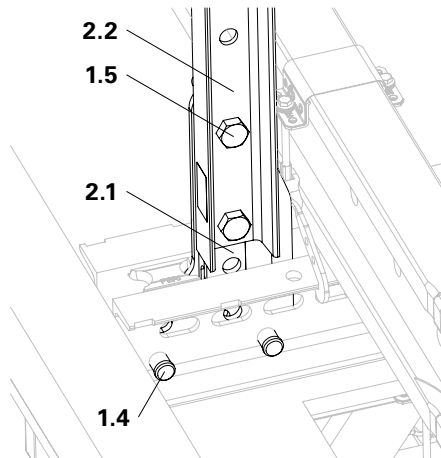

Fig. A3.03a

Waler Jack with Connector VARIOKIT

Pos.	Designation	Pieces
1.2	Waler Jack with Connector VARIOKIT	2x
1.4	Fitting Pins Ø 21 mm (1.4) Mount Corner Connector SRU VARIOKIT (2.1) onto the Steel Waler SRU U120 (1.1) using 2x Fitting Pins Ø 21 mm (1.4), and secure with cotter pins 4/1, galv. 21 mm (1.4)	4x

Assembly

Mount Waler Jack with Connector VARIOKIT (1.2) onto the Steel Waler SRU U120 (1.1) using 2x Fitting Pins Ø 21 mm (1.4), and secure with cotter pins 4/1, galv. (Fig. A3.03b)

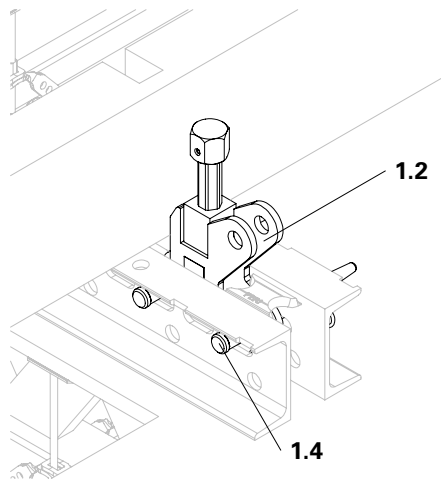

Fig. A3.03b

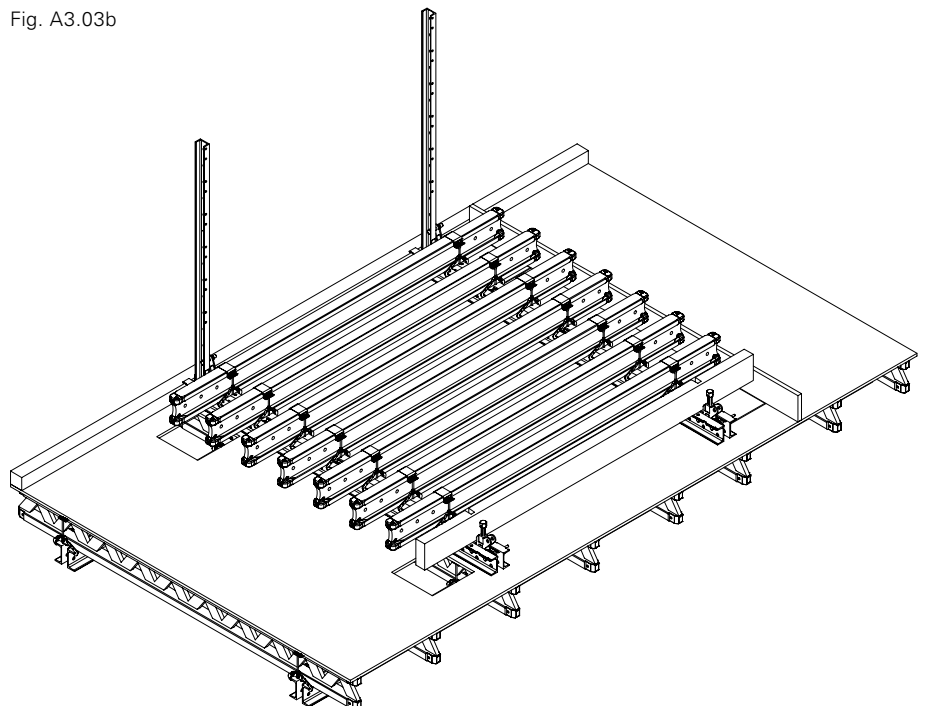

Fig. A3.03

Tie Rod DW 15



Do not use any Tie Rods DW 15 which are damaged (bent or buckled).



Ensure tie rods are not damaged (bent or buckled) when inserted through the Anchor Brackets VARIOKIT. (Fig. A3.04a)

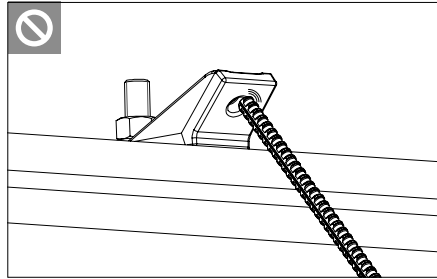

Fig. A3.04a



Carefully insert tie rods into the Anchor Brackets VARIOKIT. (Fig. A3.04b)

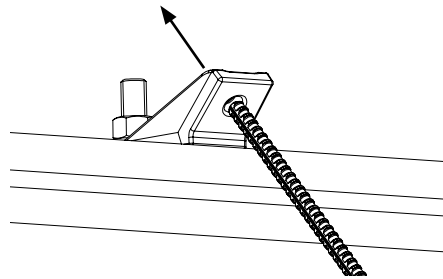

Fig. A3.04b



Ensure that the Tie Rod DW 15 (5.2) is not positioned on the steel waler as it will be bent. (Fig. A3.04c)

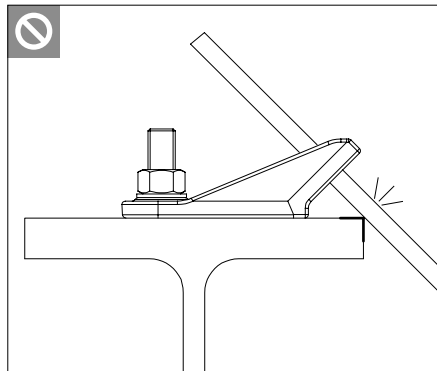

Fig. A3.04c



During the planning of the VARIOKIT Cantilever Bracket, attention must be paid that there is sufficient spacing between the Tie Rods DW 15 (5.2) and the steel girders of the bridge. (Fig. A3.04d + Fig. A3.04e)

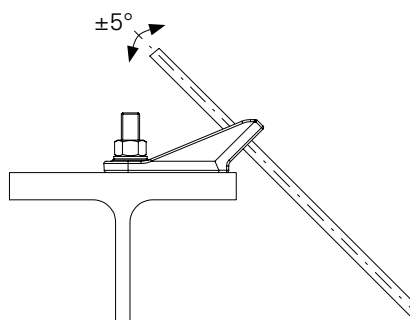

Fig. A3.04d

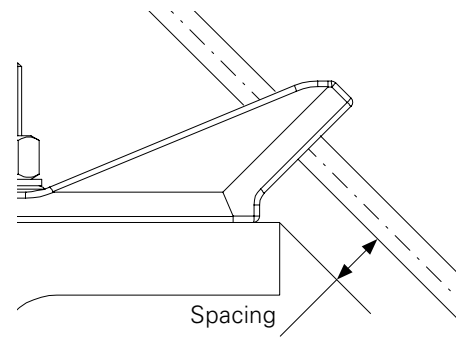

Fig. A3.04e

Device Suspension Lock VCB DW 15

Pos.	Designation	Pieces
5.1	Suspension Lock VCB DW 15	1x
5.2	Tie Rod DW 15	1x
5.3	Hex. Nut DW 15	1x
5.4	Spacer Tube rough DR 22	1x
5.5	Triple Wingnut DW 15	1x
5.6	Cone DR 22	1x



Due to the 20 mm overlap, the nut is prevented from sliding back after bolting the Device Suspension Lock VCB DW 15 to the Steel Waler SRU U120.

Assembly

1. Cut the Tie Rod DW 15 (5.2) to length according to the project general arrangement drawings. (Fig. A3.05a)
2. Screw Triple Wingnut DW 15 (5.5) on the Tie Rod DW 15 (5.2). (Fig. A3.05a)
3. Slide Suspension Lock VCB DW 15 (5.1) onto the Tie Rod DW 15 (5.2). (Fig. A3.05b)
4. Screw Hex. Nut DW 15 (5.3) onto the Tie Rod DW 15 (5.2). The tie rod protrusion is 20 mm. (Fig. A3.05c)
5. Insert Tie Rod DW 15 (5.2) complete with Hex. Nut DW 15 (5.3) into the Suspension Lock VCB DW 15. (Fig. A3.05d)
6. Loosen Triple Wingnut DW 15 (5.5) in the direction of the Suspension Lock VCB DW 15. (Fig. A3.05d)
7. Slide Spacer Tube rough DR 22 (5.4) onto the Tie Rod DW 15 until there is contact with the Triple Wingnut DW 15. (Fig. A3.05e)
8. Push Cone DR 22 (5.6) onto the tie rod. (Fig. A3.05f)
9. Insert the cylindrical supports of the Cone DR 22 (5.6) into the Spacer Tube rough DR 22 (5.4) as far as possible. (Fig. A3.05g)

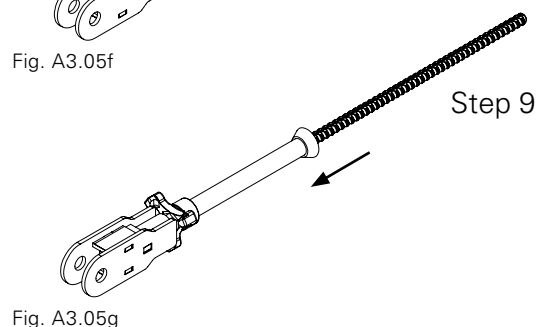
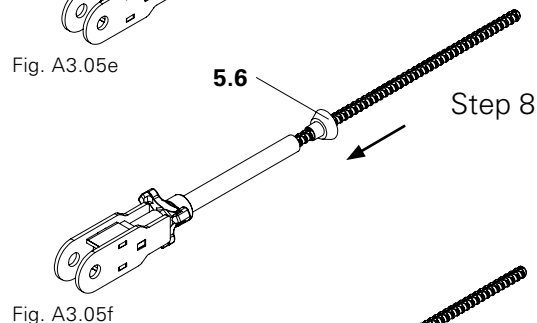
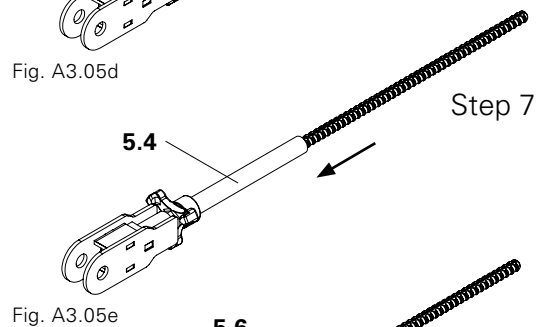
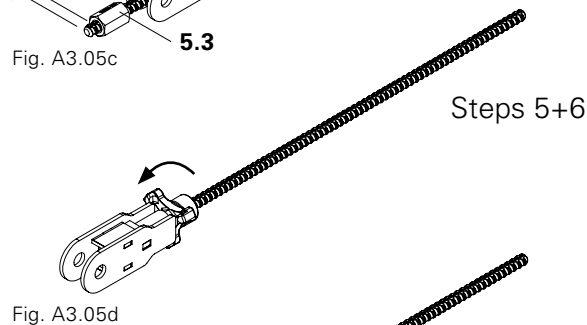
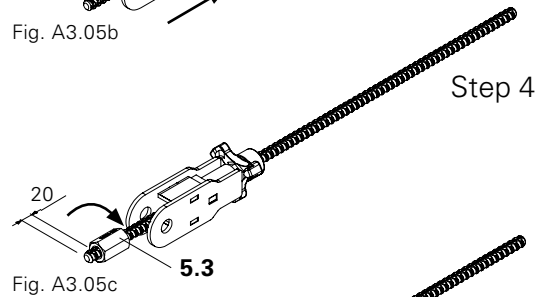
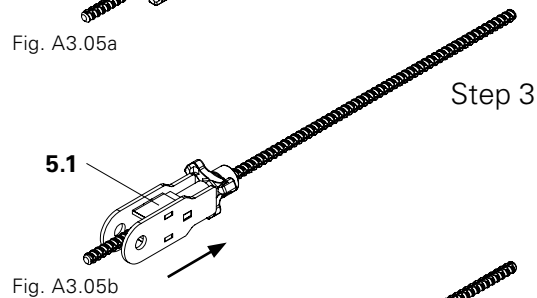
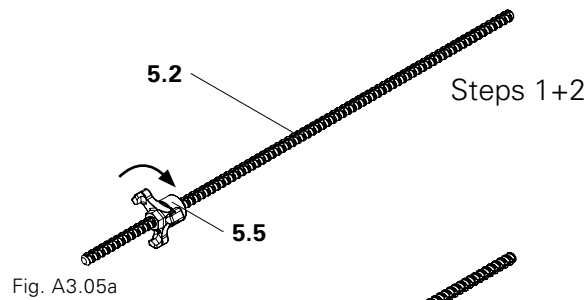



Pre-assembled Device Suspension Lock VCB DW 15 (5.7) ready for mounting on the Steel Waler SRU U120 (1.1).

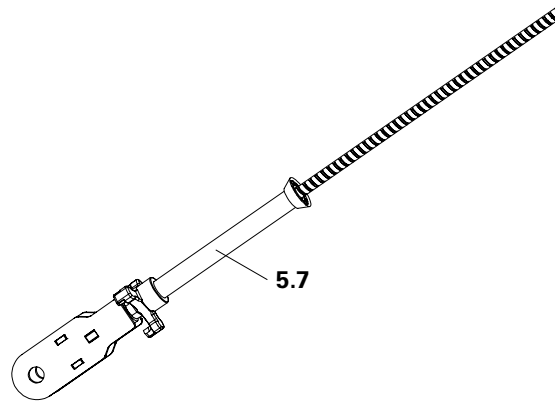

Fig. A3.06



The exact position is given in the operational planning drawings.

Pos.	Designation	Pieces
5.7	Device Suspension Lock VCB DW 15	2x
1.4	Fitting Pins Ø 21 mm	2x

Installation

Install pre-assembled Device Suspension Lock VCB DW 15 (5.7) in the Steel Waler SRU U120 (1.1) using 1x Fitting Pin Ø 21 mm (1.4), and secure with cotter pin 4/1, galv. (Fig. A3.07a)

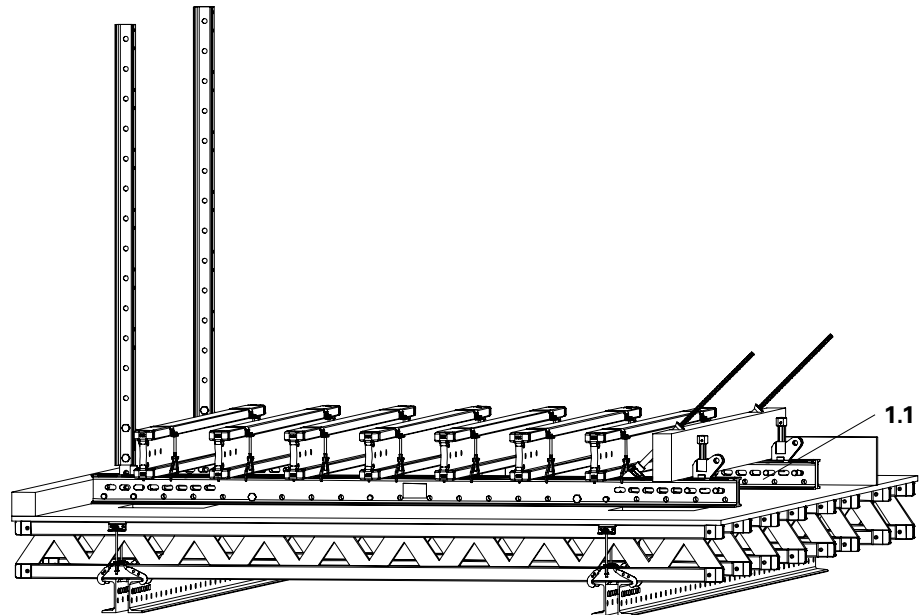

Fig. A3.07

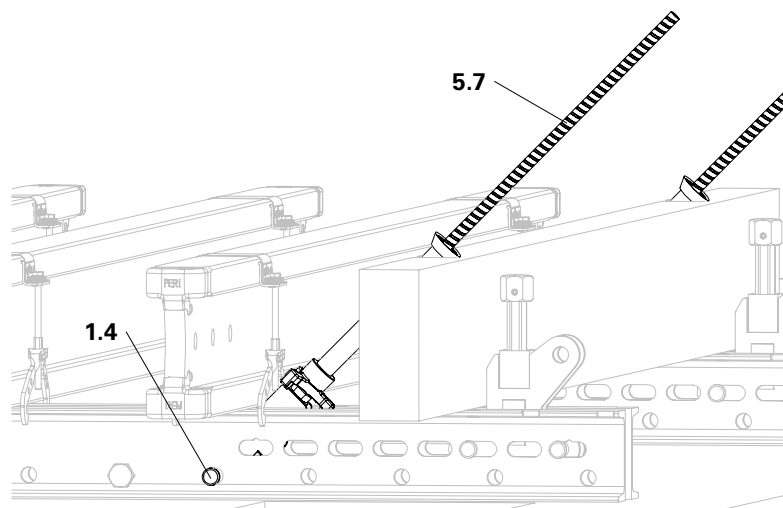

Fig. A3.07a

Planking



Select fastening means in accordance with the planking (plywood formlining, tongue and groove boards, open formwork etc.).



In the front area, take into account the accessibility to the lower sealing. Do not close the last girder field. Cut the planking to size and fix on the mounted planking for transport. Carry out the cutting with the openings for penetrating the suspensions.

Assembly

1. Fix planking (2.7) to Girders VT 20K (2.5).
2. Fix toe board (2.10) tightly against the planking (2.7) on the Guardrail Post RCS/SRU 184 (2.2) by means of screws.



After completion, make sure the planking is fastened properly.



Depending on the type of planking, the platforms can be mounted shorter at both lateral ends if necessary; after the platforms have been suspended, the platform joints can be closed using filler plates.

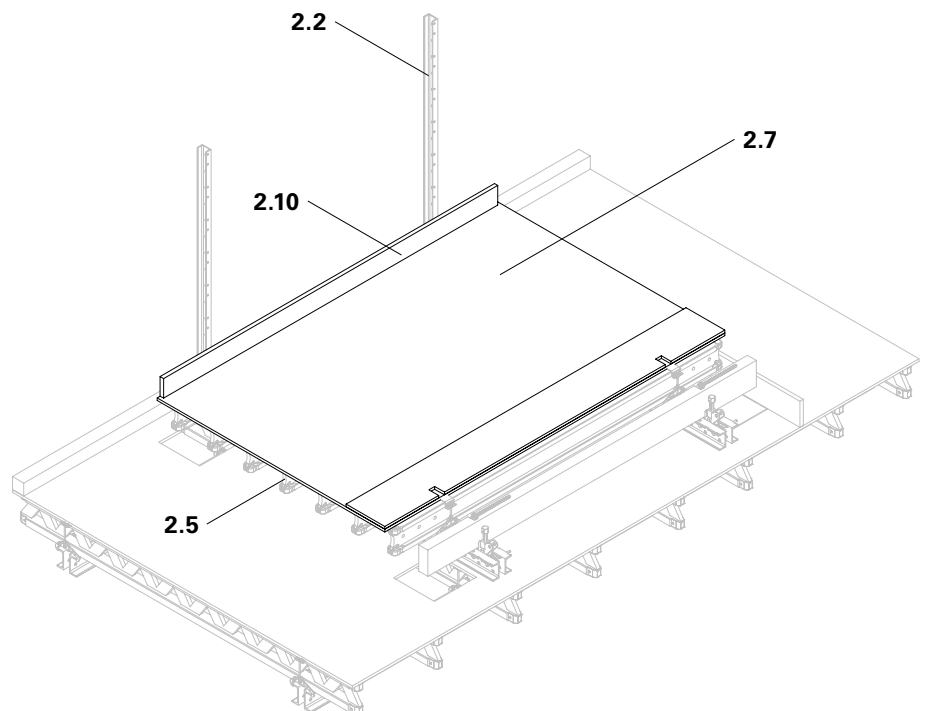

Fig. A4.01

Stopend formwork on the planking



The stopend formwork used is given in the project-specific drawings.

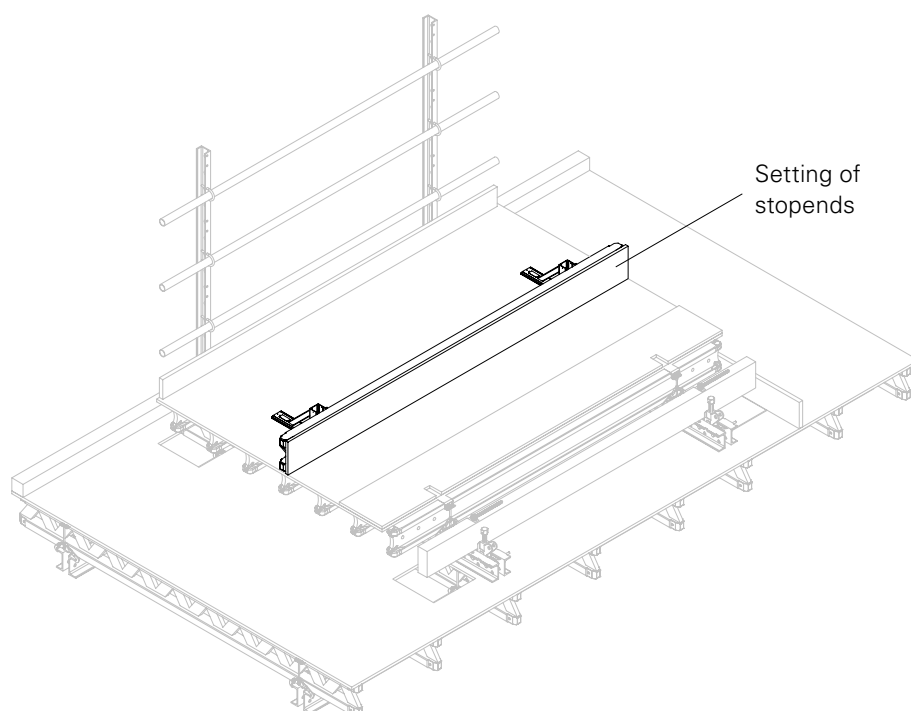

Fig. A4.02

Rear guardrails with Guardrail Post RCS/SRU 184



Rear guardrails are to be installed on all platforms.

Pos.	Designation	Pieces
2.3	Steel Scaffold Tube Ø 48.3 x 3.2	3x
2.4	Clamp A64 DIN 3570 M12, galv.	6x
2.4.1	Nut ISO 4032 M18-8	12x

Assembly

1. Adjust the length of the Steel Scaffold Tube Ø 48.3 x 3.2 (2.3) to suit the element width.
2. Position Steel Scaffold Tube Ø 48.3 x 3.2 (2.3) on the guardrail post.
3. Bring Clamp A64 DIN 3570 M12 (2.4) over the Steel Scaffold Tube Ø 48.3 x 3.2 (2.3) and insert into the holes of the guardrail post.
4. Secure both ends of the Clamp A64 DIN 3570 M12 (2.4) at the rear of the guardrail post using Nuts ISO 4032 M18-8 (2.4.1).



Check Steel Scaffold Tube Ø 48.3 x 3.2 (2.3) to ensure it is firmly in place.

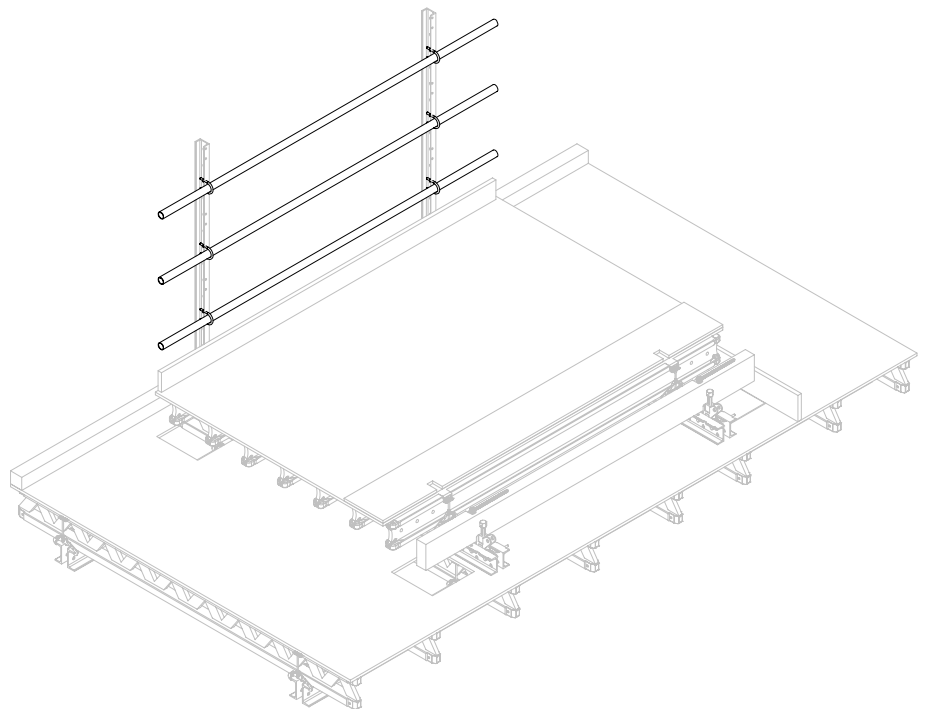

Fig. A5.01

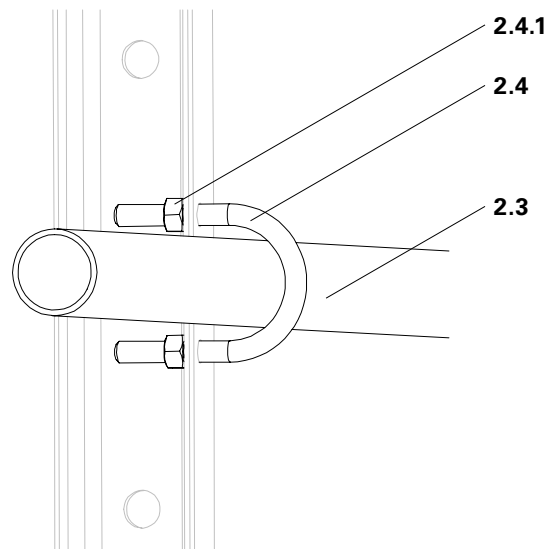

Fig. A5.01a

Lateral guardrails with Guardrail Post SCS 150



Lateral guardrails are required to be installed on all end platforms.

Pos.	Designation	Pieces
2.3	Steel Scaffold Tube Ø 48.3 x 3.2	3x
2.4	Clamp A64 DIN 2570 M12	6x
2.11	Guardrail Post Holder Multi	2x
2.12	Guardrail Post SCS 150	2x
2.10	Toe Board	1x
2.13	Guardrail Connection Plate ACS/SCS	6x

Assembly

1. Mount Guardrail Post Holder Multi (2.11) on both sides of the Girder VT 20K (2.5) using 6x Torx 6 x 60 or M8 x 100 MU.
2. Insert Guardrail Post SCS 150 (2.12) into the Guardrail Post Holder Multi (2.11) and connect using 2x Bolts M20 and Nuts M20 x 120.
3. Fix toe board (2.10) in bottom holes of the Guardrail Post SCS 150 (2.12) using F.H. Bolts M8 x 70 MU.
4. Fix Guardrail Connection Plate ACS/SCS (2.13) to Guardrail Post SCS 150 (2.12) using F.H. Bolts M8 x 100 MU. (Fig. A5.02a)
5. Adjust the length of the Steel Scaffold Tube Ø 48.3 x 3.2 (2.3) to suit the element width.
6. Position Steel Scaffold Tube Ø 48.3 x 3.2 (2.3) on the Guardrail Post SCS 150 (2.12).
7. Bring Clamp A64 DIN 3570 M12 (2.4) over the Steel Scaffold Tube Ø 48.3 x 3.2 (2.3) and insert into the holes of the Guardrail Connection Plate ACS/SCS (2.13).
8. Secure both ends of the Clamp A64 DIN 3570 M12 (2.4) at the rear of the guardrail post using Nuts ISO 4032 M18-8.

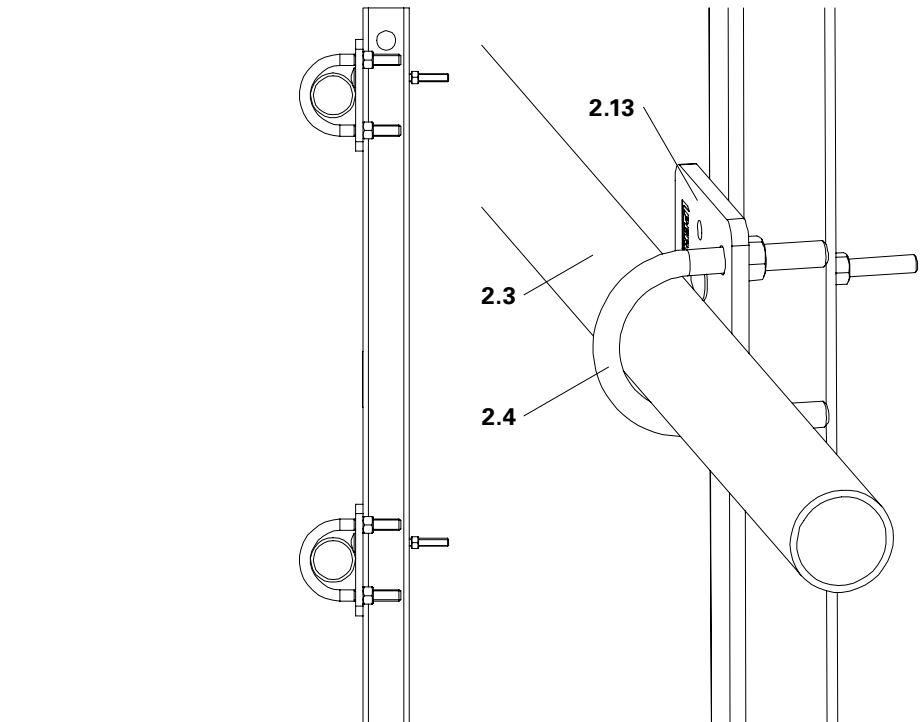

Fig. A5.02a

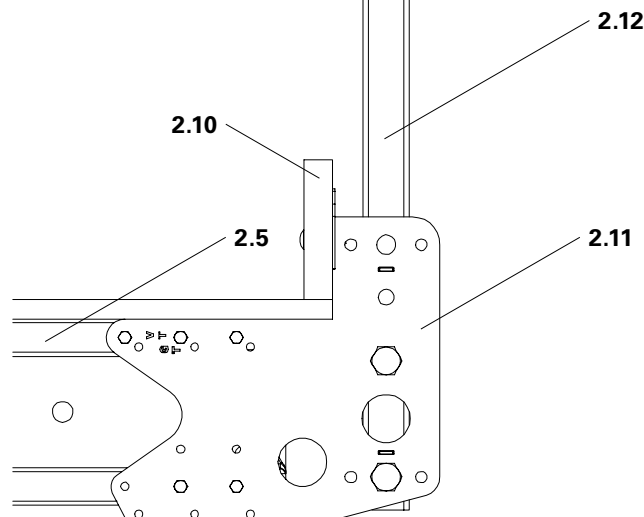

Fig. A5.02



Check Steel Scaffold Tube Ø 48.3 x 3.2 (2.3) to ensure it is firmly in place.

Enhancing the assembly construction



- Now supplement the prepared assembly area with vertical supports.
- More information can be provided by PERI on request.

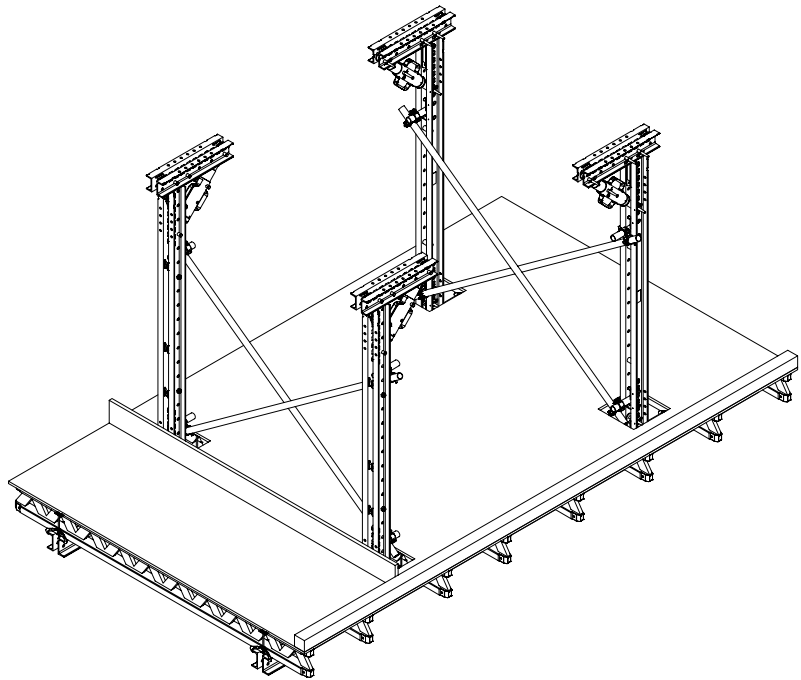

Fig. A6.01

Preparation



- **Secure the platform during and after positioning against falling to the ground as well as slipping.**
- **Do not stand under the suspended load.**
- **Do not step on the suspended load.**



The pre-assembled platform can be positioned without the use of a crane on the previously erected assembly trestle with the help of construction site lifting equipment. (Fig. A6.02)

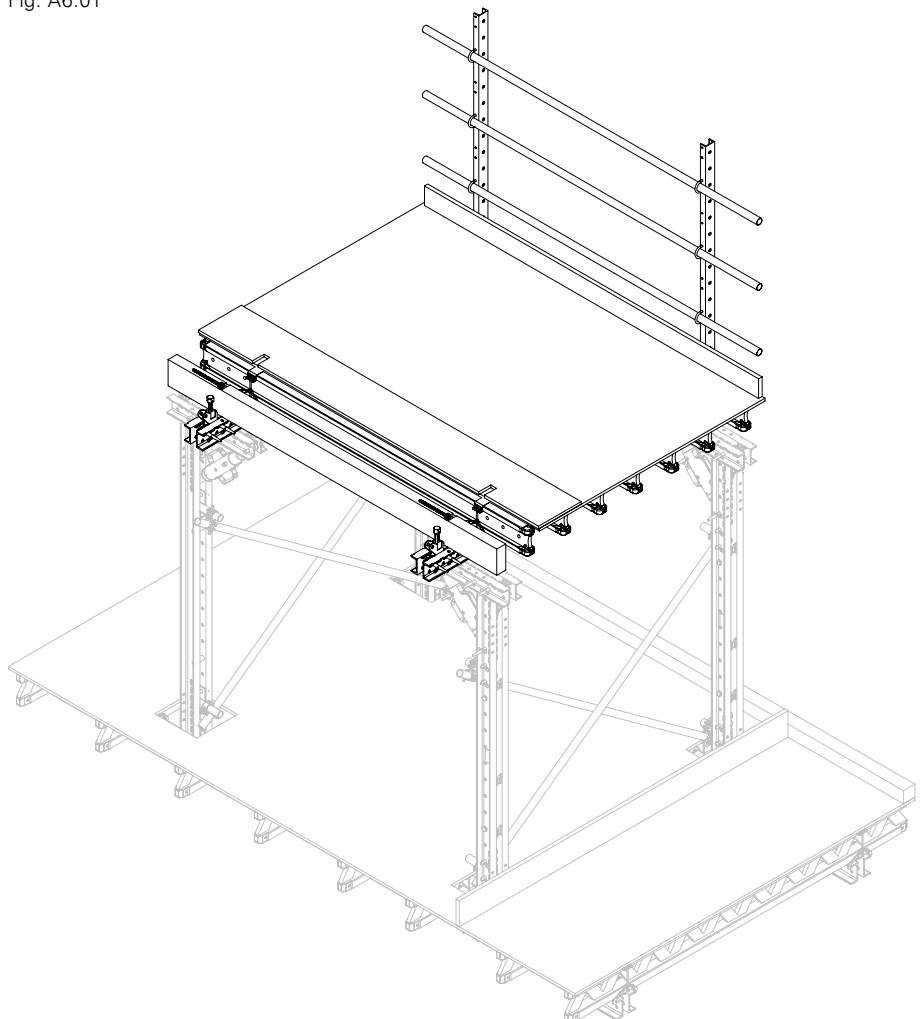

Fig. A6.02

Horizontal Waler Jack with Connector VARIOKIT



Horizontally align the Waler Jack with Connector VARIOKIT and bolt to the Steel Waler SRU in accordance with the project-specific assembly drawing.

Pos.	Designation	Pieces
1.2	Waler Jack with Connector VARIOKIT	2x
1.4	Fitting Pins Ø 21 mm	4x

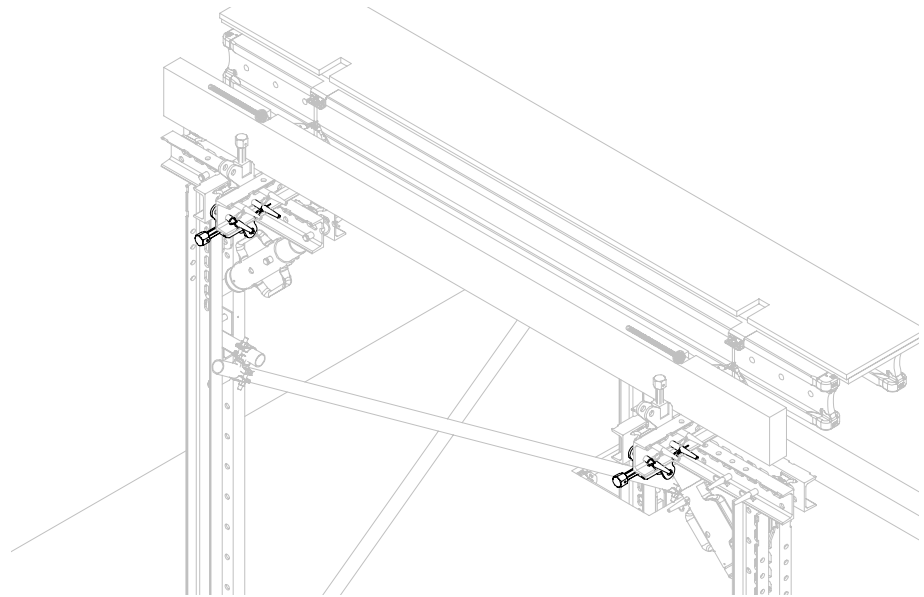

Fig. A6.03

Assembly

Mount Waler Jack with Connector VARIOKIT (1.2) onto the Steel Waler SRU U120 (1.1) using 2x Fitting Pins Ø 21 mm (1.4), and secure with cotter pins 4/1, galv. (Fig. A6.03a)

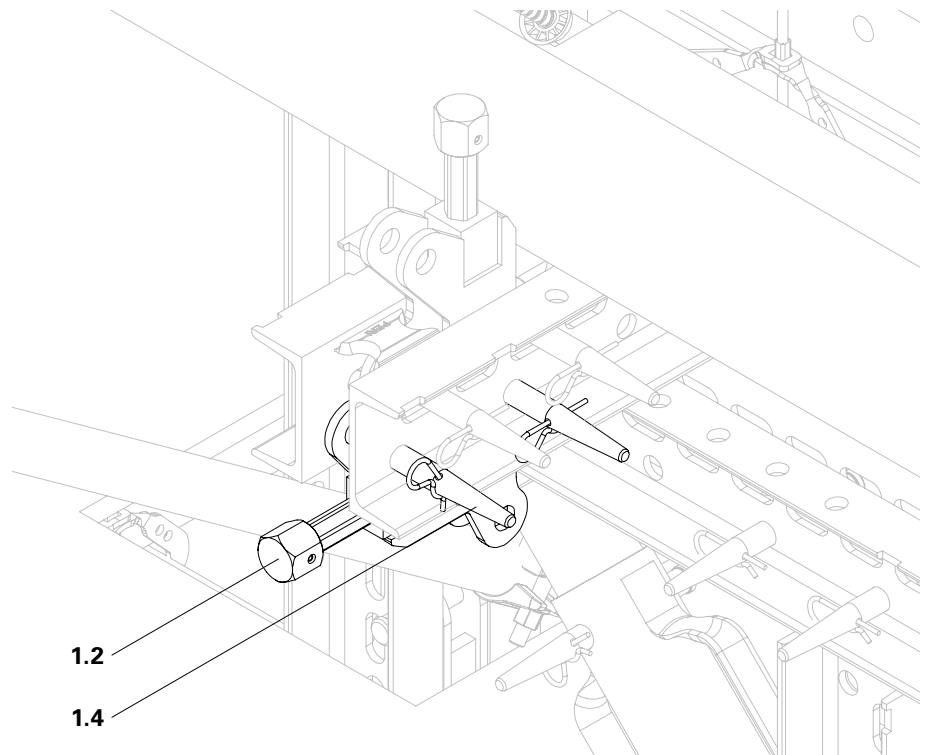

Fig. A6.03a

Vertical Steel Waler SRU U120

Pos.	Designation	Pieces
1.1	Steel Waler SRU U120	2x
1.4	Fitting Pins Ø 21 mm	2x

Assembly

Mount Steel Waler SRU U120 (1.1) onto the Waler Jack with Connector VARIOKIT (1.2) using 1x Fitting Pin Ø 21 mm (1.4), and secure with cotter pin 4/1, galv. (Fig. A6.04a)

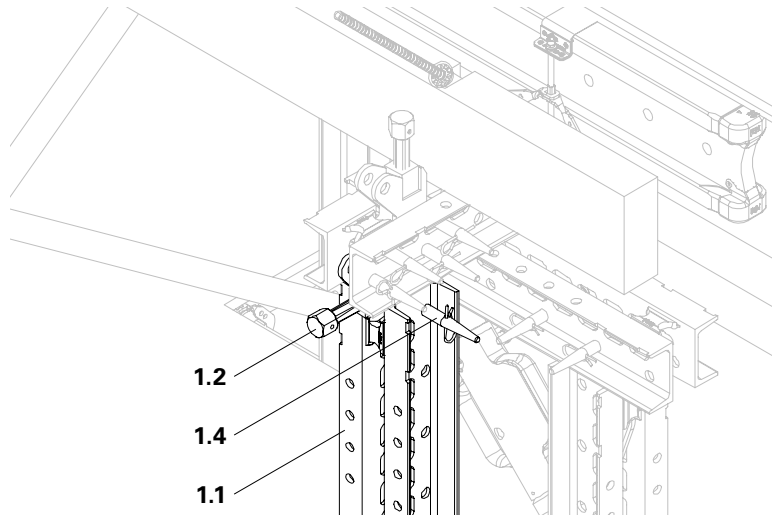

Fig. A6.04a

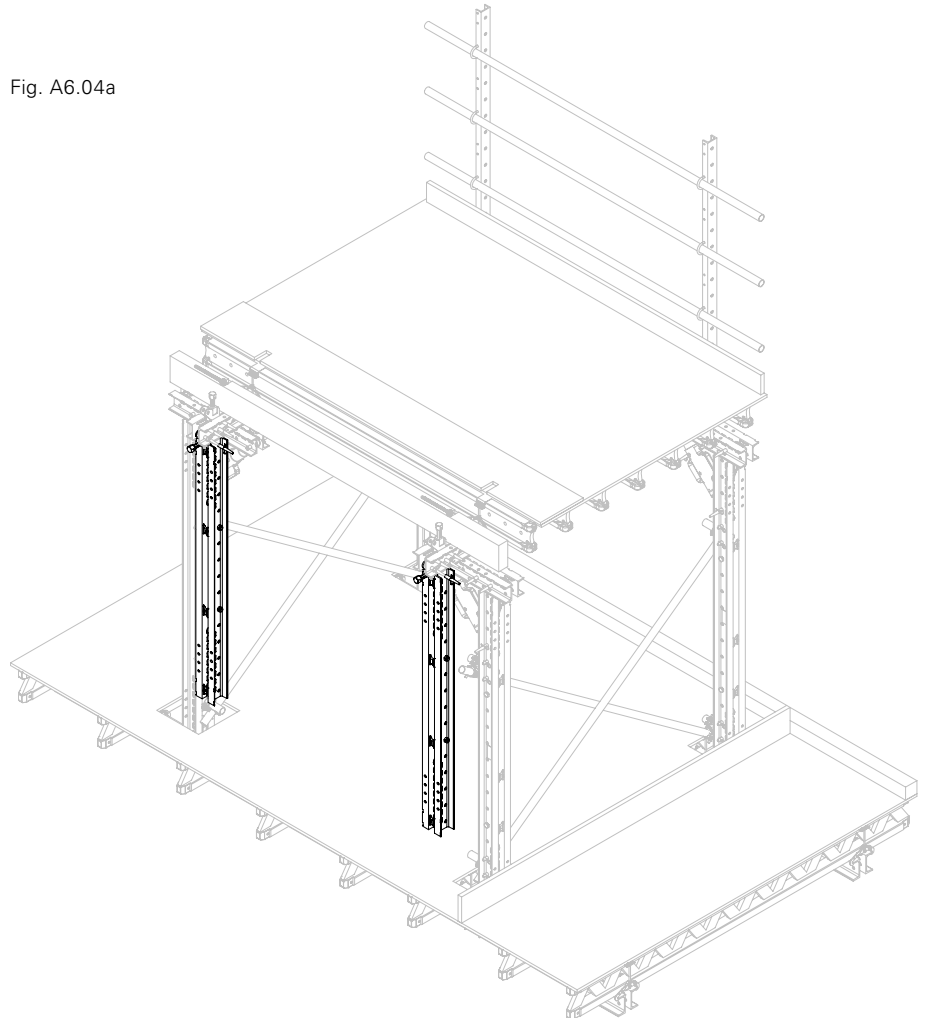

Fig. A6.04

Formwork unit triangle



Evenly spindle out the Heavy-Duty Spindles SLS (1.3), and check the angle of the two Steel Walers SRU U120 – which is specified in the general arrangement drawing – with a gauge after installing the spindles.

Pos.	Designation	Pieces
1.3	Heavy-Duty Spindle SLS	2x
1.4	Fitting Pins Ø 21 mm	4x
2.3	Steel Scaffold Tube Ø 48.3 x 3.2	2x
2.8	Standard Coupler NK 48/48	4x

Assembly of Heavy-Duty Spindles SLS

Mount the extended Heavy-Duty Spindles SLS (1.3) – the spindling length is specified in the general arrangement drawings – onto the two Steel Walers SRU U120 (1.1) using 2x Fitting Pins Ø 21 mm (1.4), and secure with cotter pins 4/1, galv. (Fig. A6.05a)

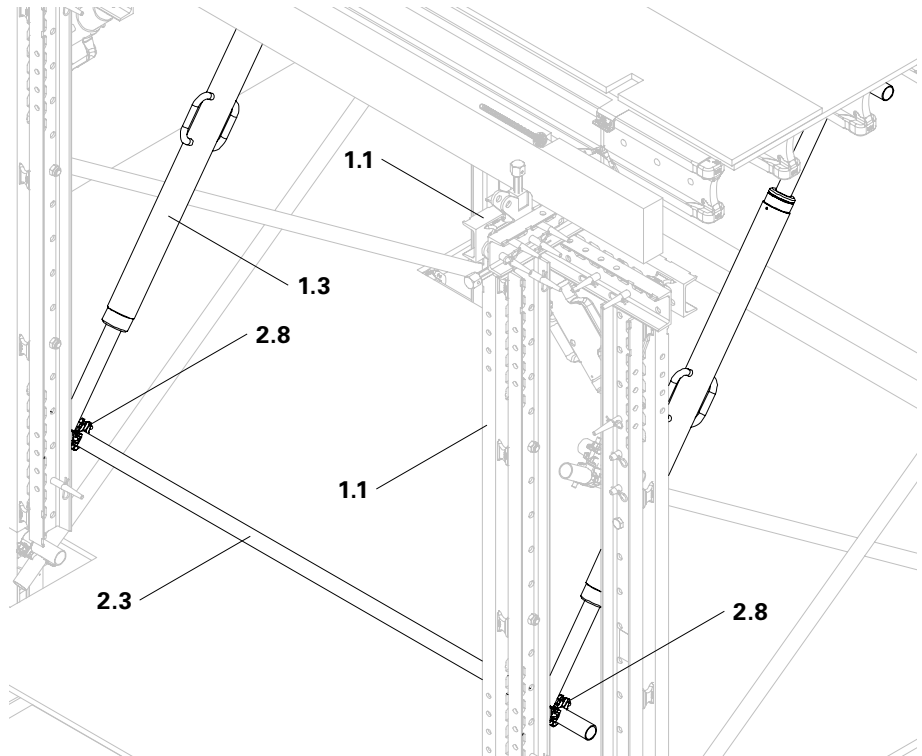

Fig. A6.05a

Assembly of scaffold tubes



The scaffold tubes must not extend over the edge of the bracket.

1. Attach 1 x Standard Coupler 48/48 (2.8) to the top and bottom ends respectively of the two heavy-duty spindles.
2. Horizontally mount 1 x Steel Scaffold Tube Ø 48.3 x 3.2 mm (2.3) to the top and bottom Standard Couplers NK 48/48 (2.8) respectively. Mount the extended Heavy-Duty Spindles SLS (1.3) – the spindling length is specified in the general arrangement drawings – onto the two Steel Walers SRU U120 (1.1) using 2x Fitting Pins Ø 21 mm (1.4) each, and secure with cotter pins 4/1, galv. 48.3 x 3.2 mm (2.3) to the top and bottom Standard Coupler NK 48/48 (2.8) respectively. (Fig. A6.05a)

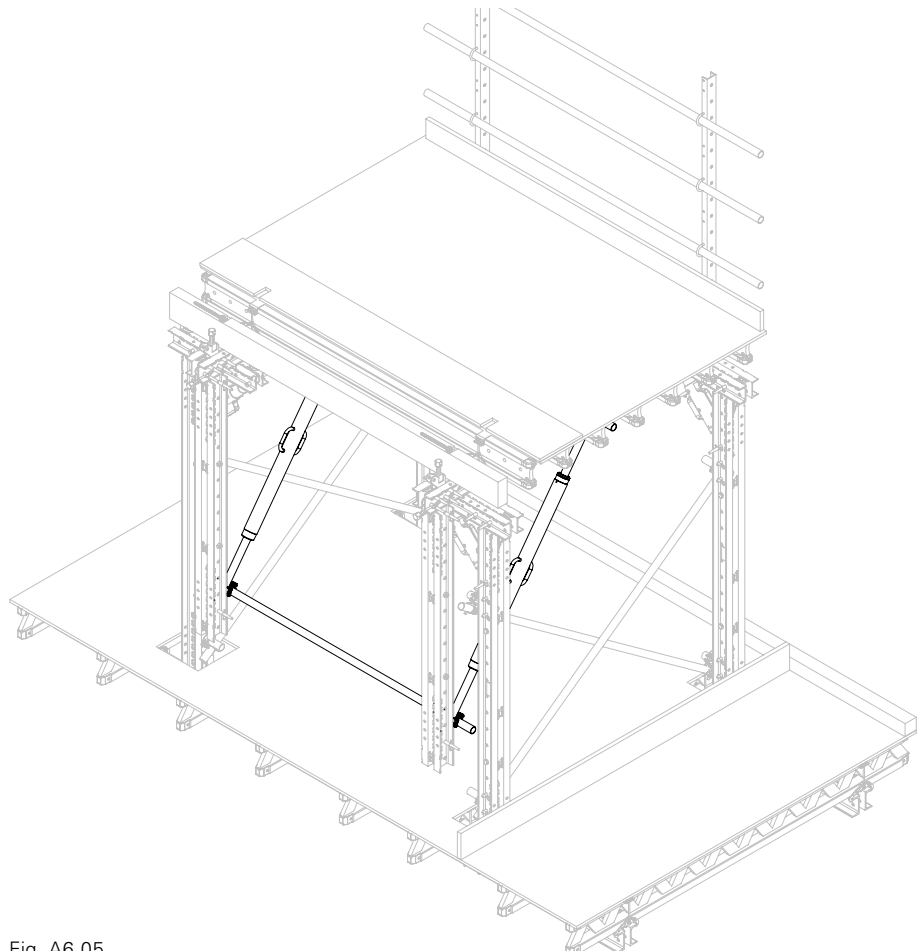

Fig. A6.05

Pos.	Designation	Pieces
2.3	Steel Scaffold Tube Ø 48.3 x 3.2	1x
2.9	Swivel Coupling DK 48/48	2x

Assembly of scaffold tube (diagonal)

1. Install 1 x Swivel Coupling DK 48/48 (2.9) each on the opposite scaffold tube ends of the horizontal Steel Scaffold Tubes Ø 48.3 x 3.2.
2. Diagonally attach Steel Scaffold Tube Ø 48.3 x 3.2 (2.3) to the Swivel Couplings DK 48/48 (2.9). (Fig. A6.06a)

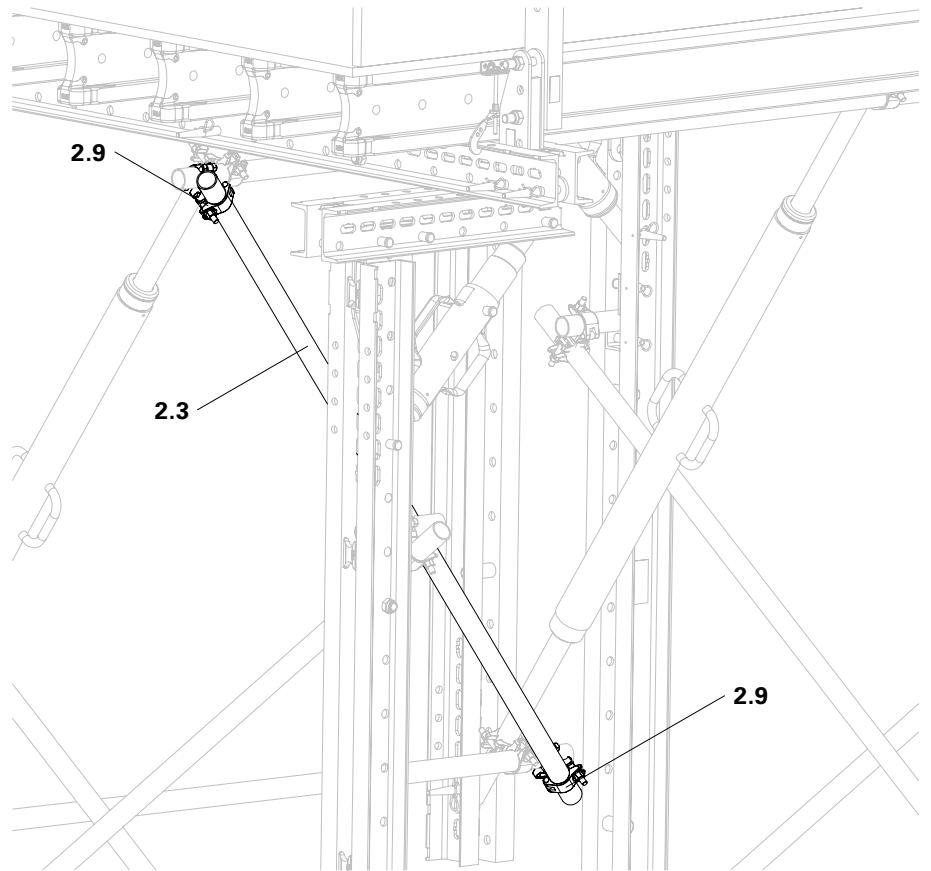

Fig. A6.06a

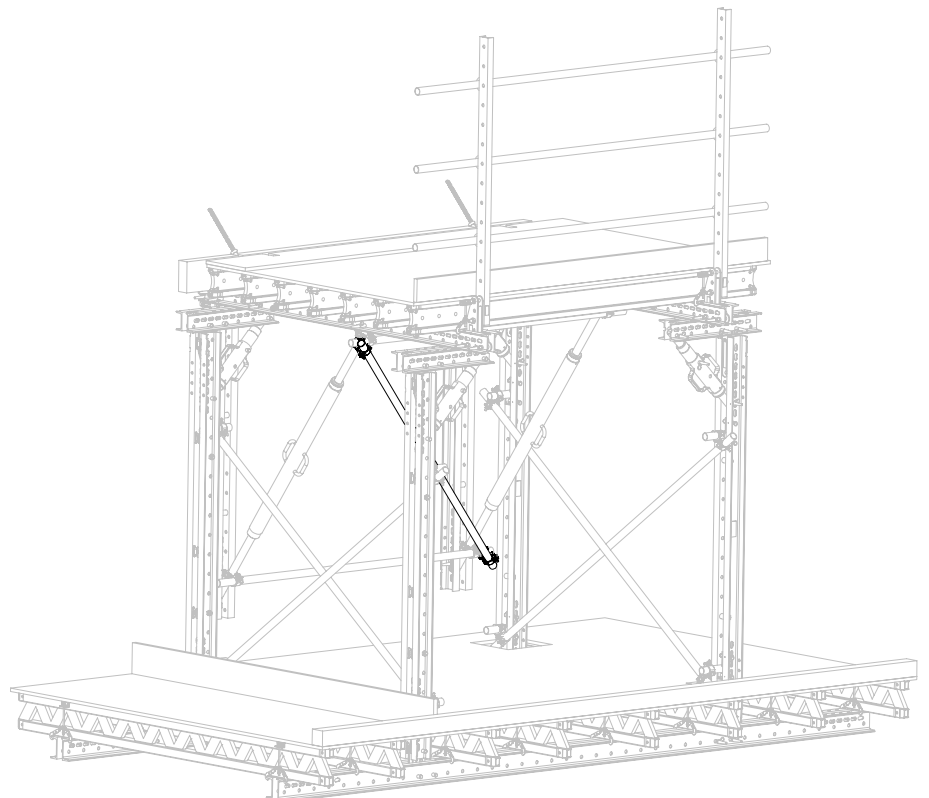

Fig. A6.06

Mounting timbers



The timbers must not extend over the edge of the bracket.

1. Mount timbers on Steel Walers SRU U120 (1.1) by means of bolts.

Lifting the cantilever bracket

1. Lift pre-assembled cantilever bracket from the assembly trestle using the Table Lifting Fork 1 t / 5.0 m (6.1). (Fig. A7.01)

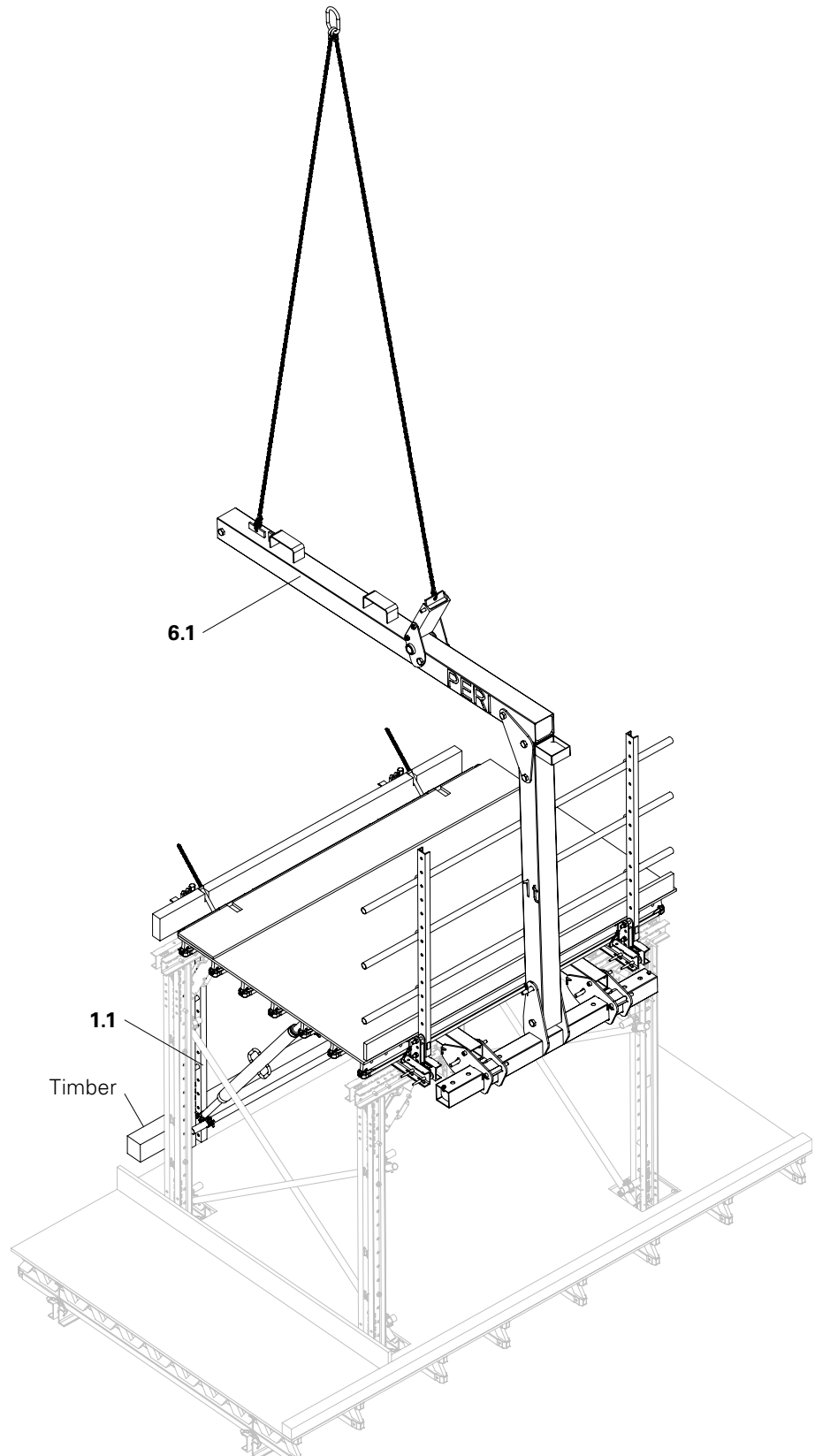

Fig. A7.01



Proof regarding the correct load action and transfer of the reaction forces into the building must be provided by a structural engineer selected by the contractor.

Possible angle deviation due to the acting force: $\pm 5^\circ$.

Resulting forces at max. load:
 $F = 70 \text{ kN}$. (Fig. A8.01)

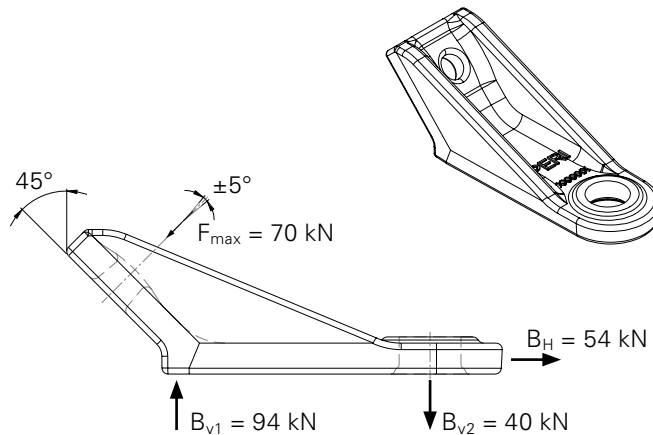

Fig. A8.01

Transfer of the resulting forces

Version 1

Fixing the Anchor Bracket VARIOKIT with welded Threaded Bolts M24 (drawn arc stud welding). (Fig. A8.02)

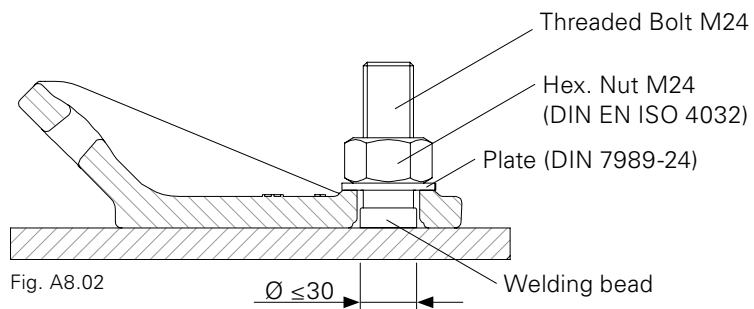

Fig. A8.02

Version 2

Welding on the Anchor Bracket VARIOKIT.



Size a_w and length l_w of the weld seam are dependent on the grade of steel used in the sub-construction.

Minimum requirements:

a_w : continually weld with $a_w \geq 5 \text{ mm}$ in the rounded area ($\text{Ø } 70 \text{ mm}$).

l_w : the length of the continuously welded extension of the weld seam is $l_w \geq 30 \text{ mm}$.

Both values a_w and l_w are to be increased if necessary according to the steel quality of the steel girders.

(Fig. A8.03)

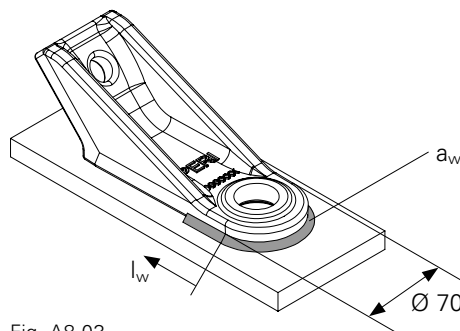

Fig. A8.03

Version 3

Bolting of the Anchor Bracket VARIOKIT.



The bolted connection must be designed in accordance with the acting forces in the applications.

(Fig. A8.04)

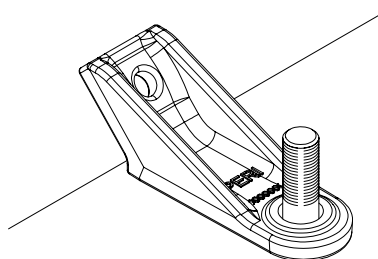

Fig. A8.04

Positioning the cantilever bracket



Risk of falling!

- Use personal protection equipment against falling (PPE) as intended and determine attachment points.
- Do not stand on suspended loads.
- Do not stand under the suspended load.
- Ensure tie rods are not damaged (bent or buckled) when inserted through the Anchor Brackets VARIOKIT. Otherwise the load-bearing capacity is no longer guaranteed.
- Remove the Table Lifting Fork 1 t / 5.0 m only when the cantilever bracket is fixed to the structure.



Positioning

Position the cantilever bracket on the building using the Table Lifting Fork 1 t / 5.0 m. (Fig. B1.01)

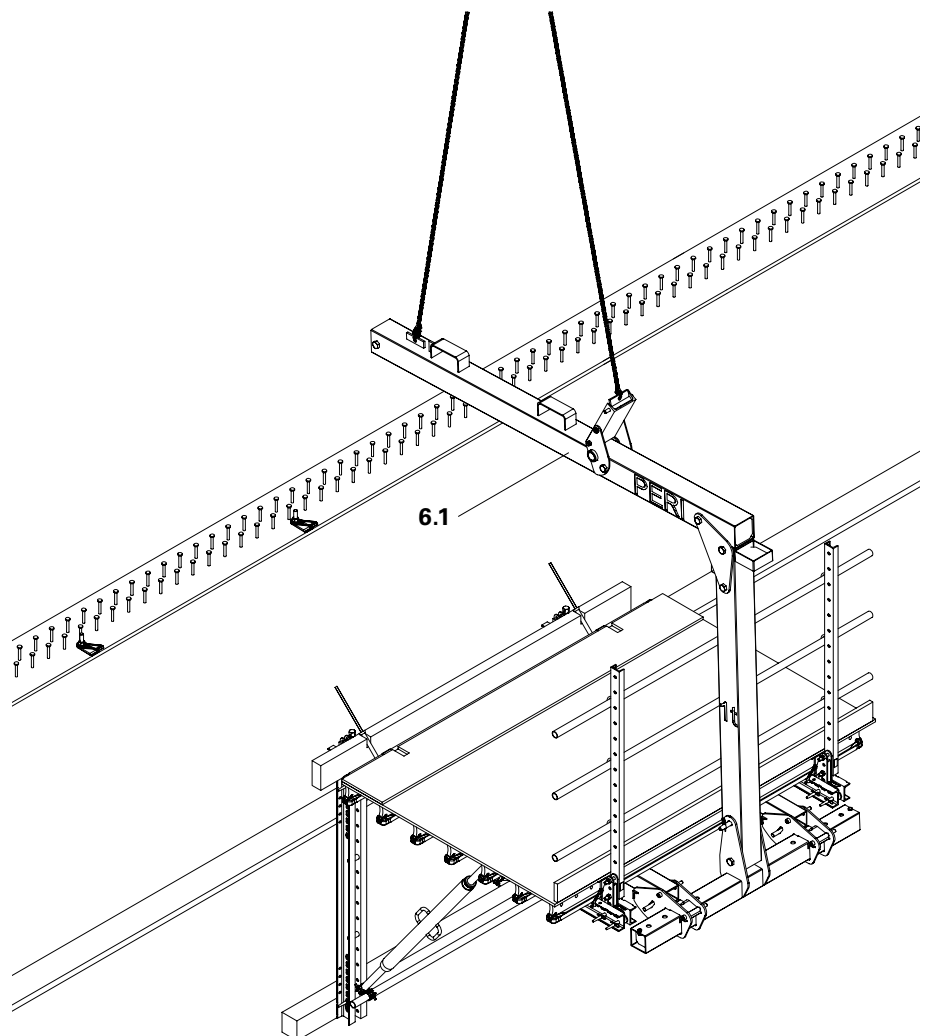

Fig. B1.01

Fixing the cantilever bracket

Pos.	Designation	Pieces
5.12	Tube Nut	2x
	Seal Ring	2x

Preparing the Tube Nut

Mount the seal ring on the offset spigot of the tube nut (5.12). (Fig. B1.02)

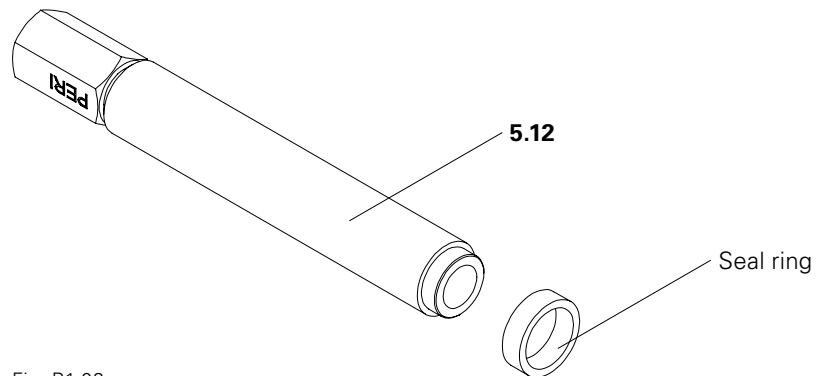

Fig. B1.02



- When positioning the cantilever bracket, do not allow any impact on the Anchor Bracket VARIOKIT.
- Do not compress Tie Rods DW 15.
- It is forbidden to use damaged (bent or compressed) Tie Rods DW 15.
- Replace damaged tie rods.
- Do not use excessive force on the seal rings.

Fixing the cantilever bracket

1. Carefully insert Tie Rods DW 15 (5.2) into the Anchor Bracket VARIOKIT (4.1).
2. Screw prepared tube nuts (5.12) onto the Tie Rods DW 15 (5.2). (Fig. B1.03)
3. By tightening the tube nuts (5.12), pull the cantilever bracket to the superstructure until the cantilever bracket is correctly positioned and inclined. (Fig. B1.03a)

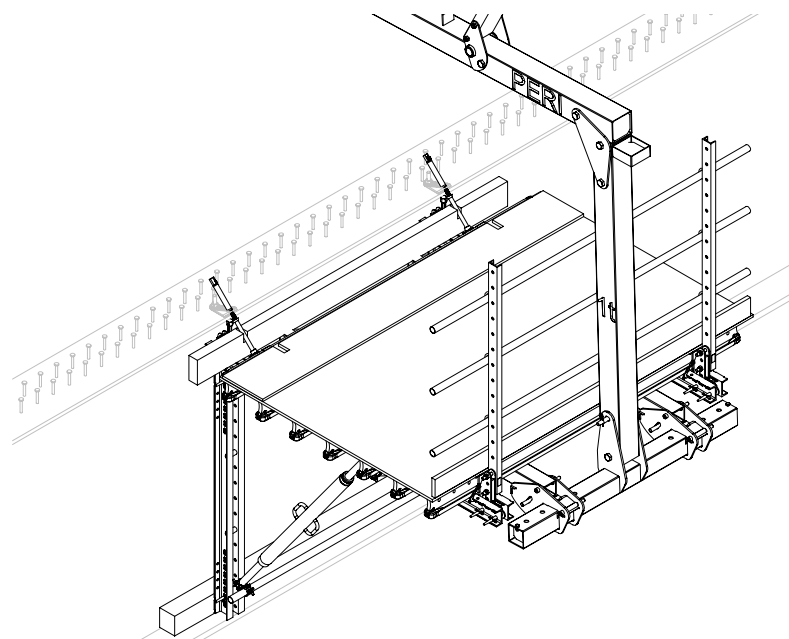

Fig. B1.03



Check the connections of the tie rods with the structure.

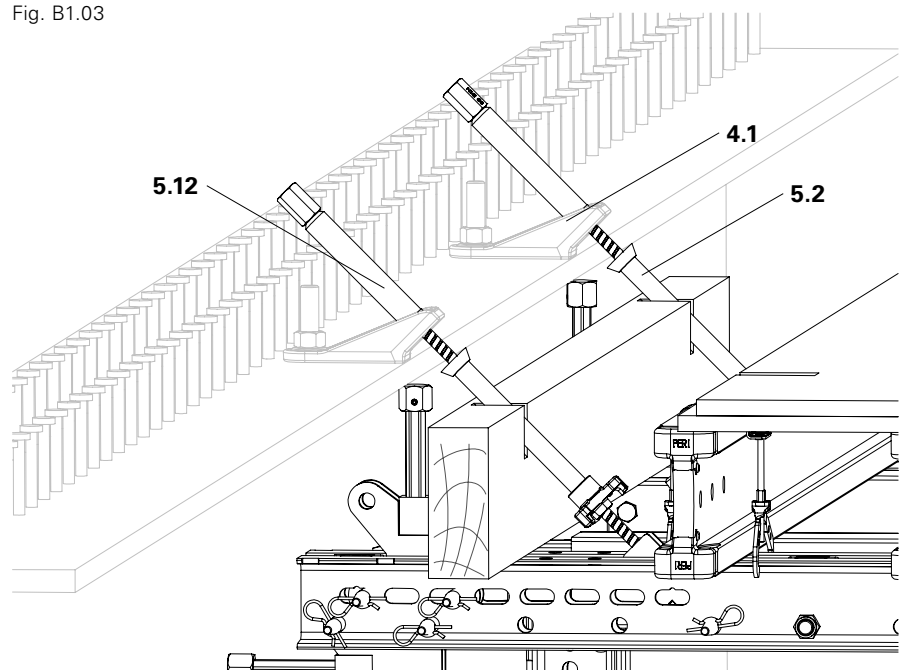

Fig. B1.03a

Closing the bottom sealing

Tighten Triple Wingnut DW 15 (5.5) until the cone and the Anchor Bracket VARIOKIT (4.1) have full surface contact.

(Fig. B2.01)

(Fig. B2.02)

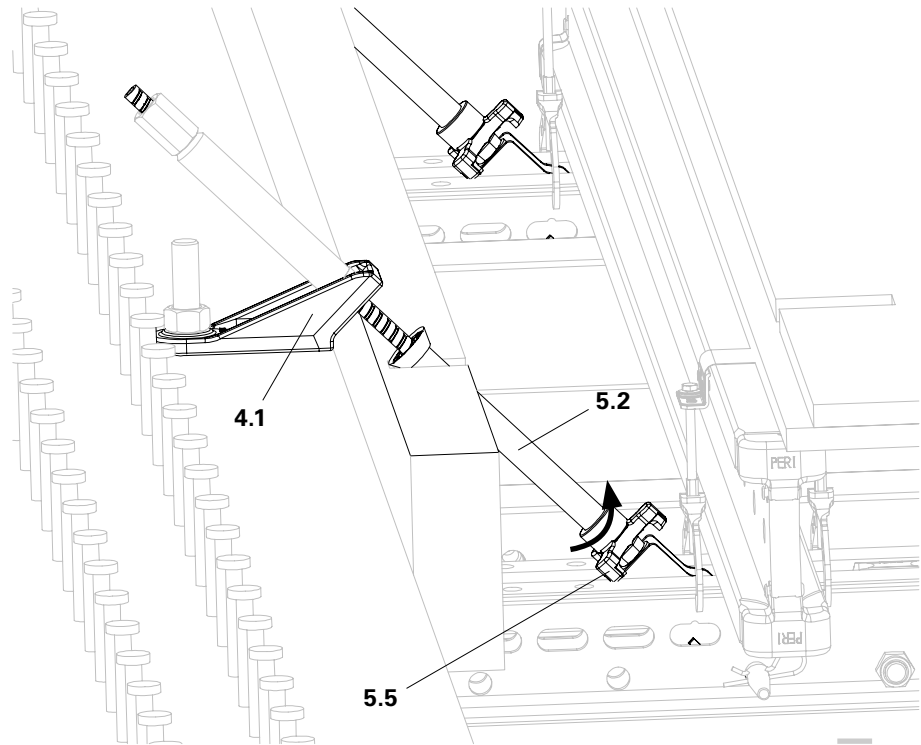

Fig. B2.01



The Tie Rod DW 15 (5.2) must protrude 20 mm to the tube nut (5.12).

(Fig. B2.02)

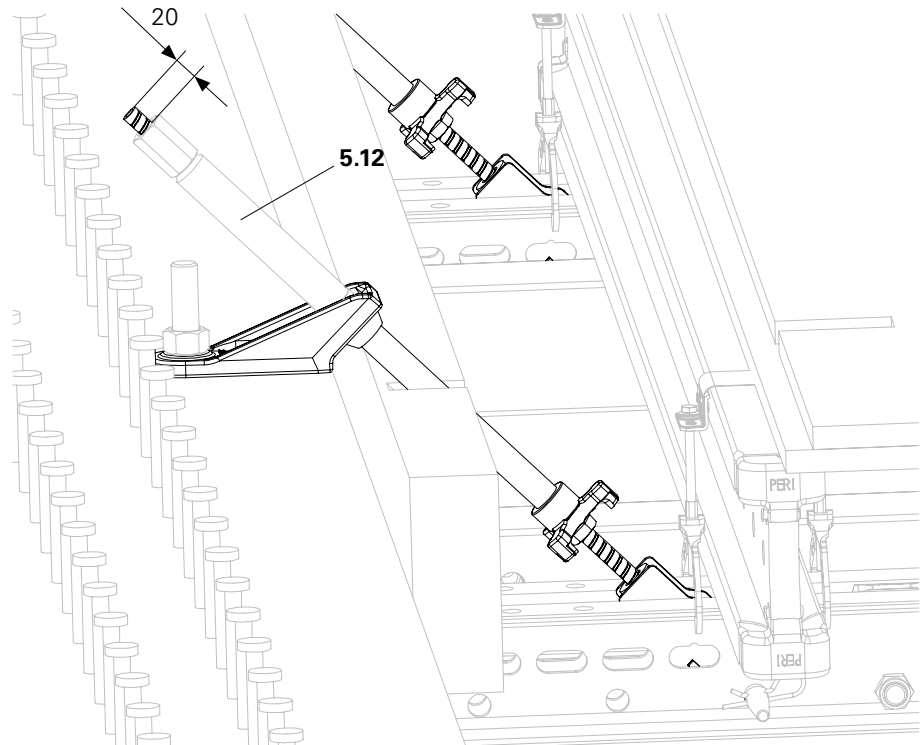

Fig. B2.02



- The Table Lifting Fork 1 t / 5.0 m is removed only when the cantilever bracket is fixed to the structure and can be loaded.
- Only access the cantilever bracket wearing PPE against falling after a competent person has checked and approved the cantilever bracket and its fixations.

Moving

After having the fixation verified and approved, remove the Table Lifting Fork 1 t / 5.0 m (6.1) with the crane. (Fig. B3.01)

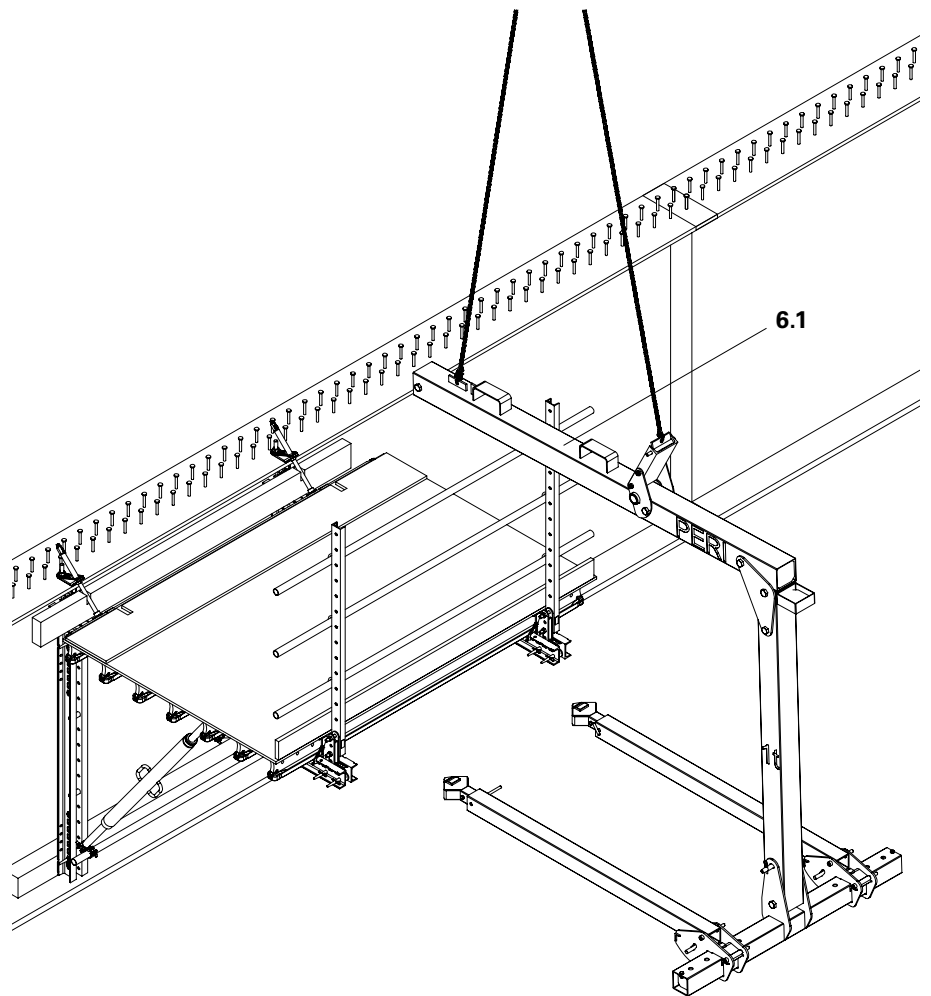

Fig. B3.01

Filler plates



- Watch out for unsecured building edges.
- Use PPE against falling.

Using filler plates

Install the filler plates (7.1) of the planking in the open space. (Fig. B4.01)

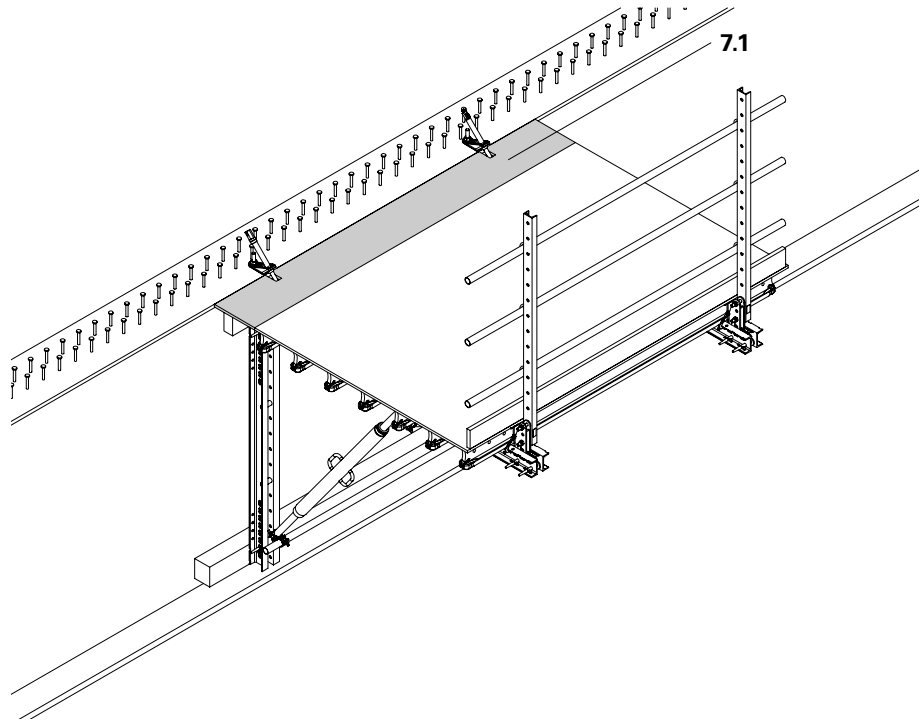

Fig. B4.01

Opening



Safety data sheet of the building foam used is to be taken into consideration.

Filling the opening with building foam

1. Fill the opening (7.2) in the planking with building foam.
2. Wait until the building foam has hardened.
3. Remove excess building foam until the level is flush with the planking surface. (Fig. B4.02)

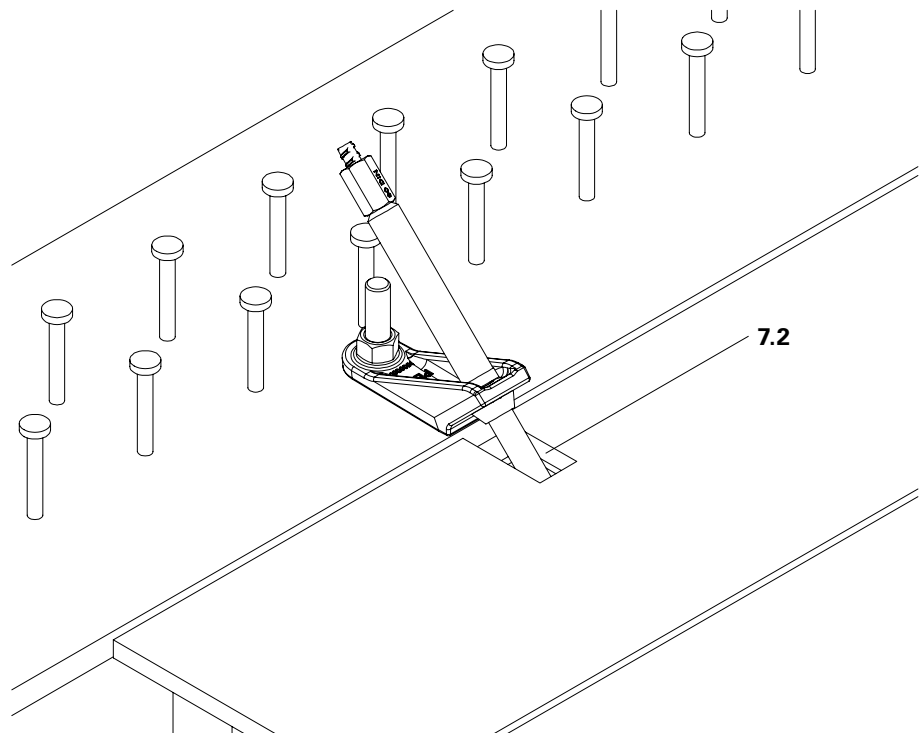

Fig. B4.02



Safety data sheet of the silicone spray used is to be taken into consideration.



Spray the tube nut with silicone spray. This makes it easier to slide on the Pipe Insulation PE 28 x 9 (5.7). (Fig. B5.01)

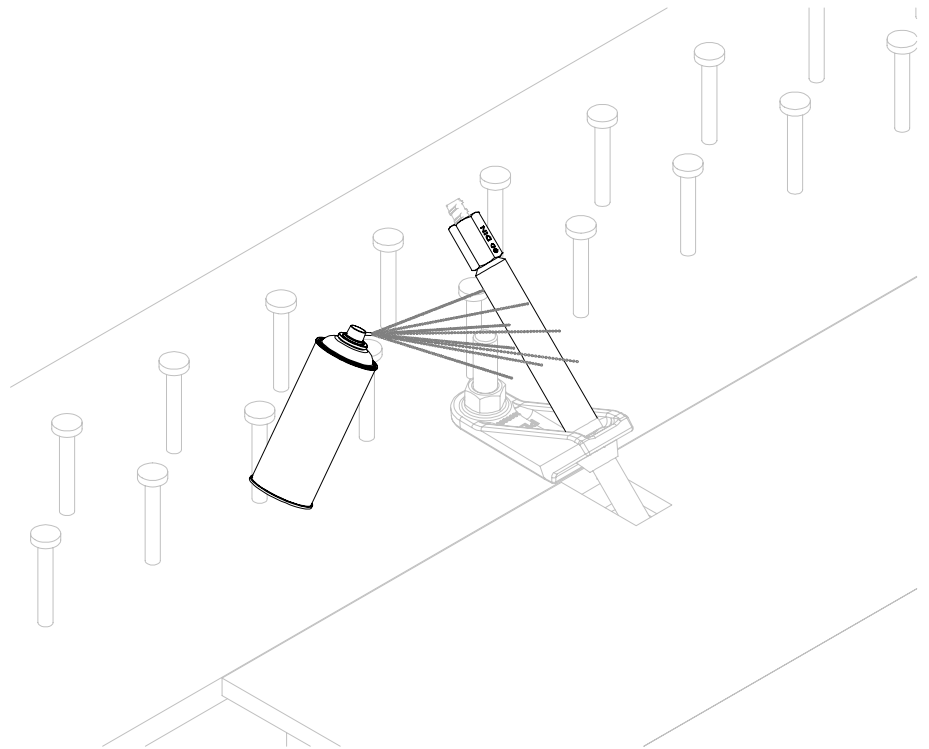

Fig. B5.01

Pipe insulation

Slide the Pipe Insulation PE 28 x 9 (5.7) onto the tube nut until it overlaps the seal ring. (Fig. B5.02)

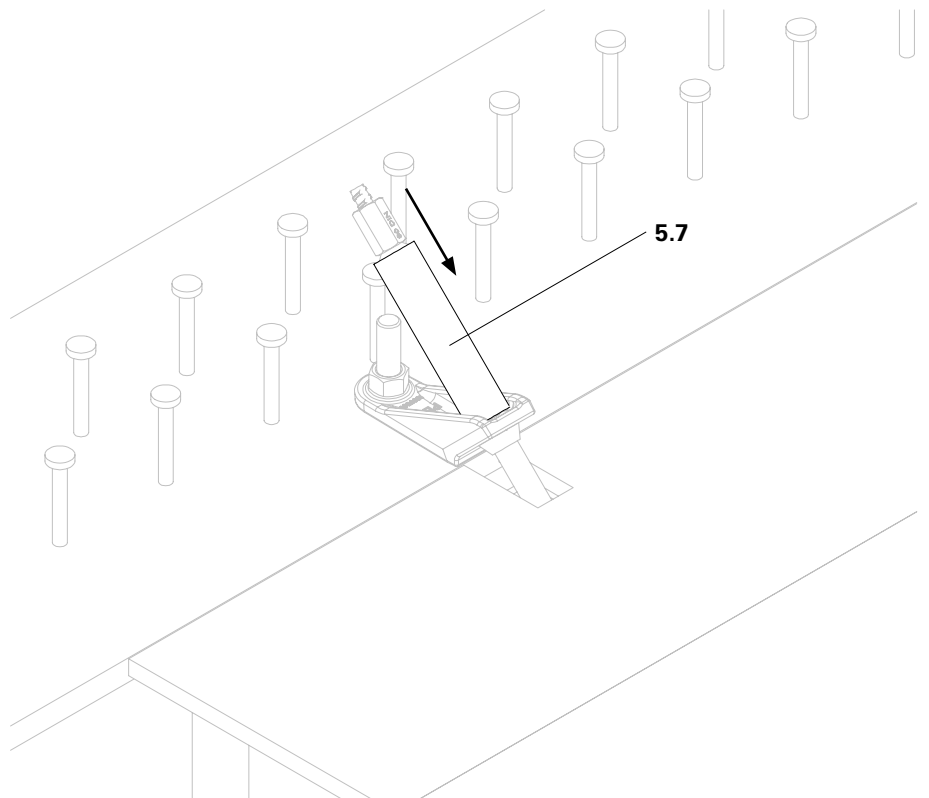

Fig. B5.02



Turn the Plug Lock VCB DW 15 until it can be completely attached.

Plug Lock VCB DW 15

Push the Plug Lock VCB DW 15 (5.8) onto the hex. nut of the tube nut as far as it will go. (Fig. B5.03)

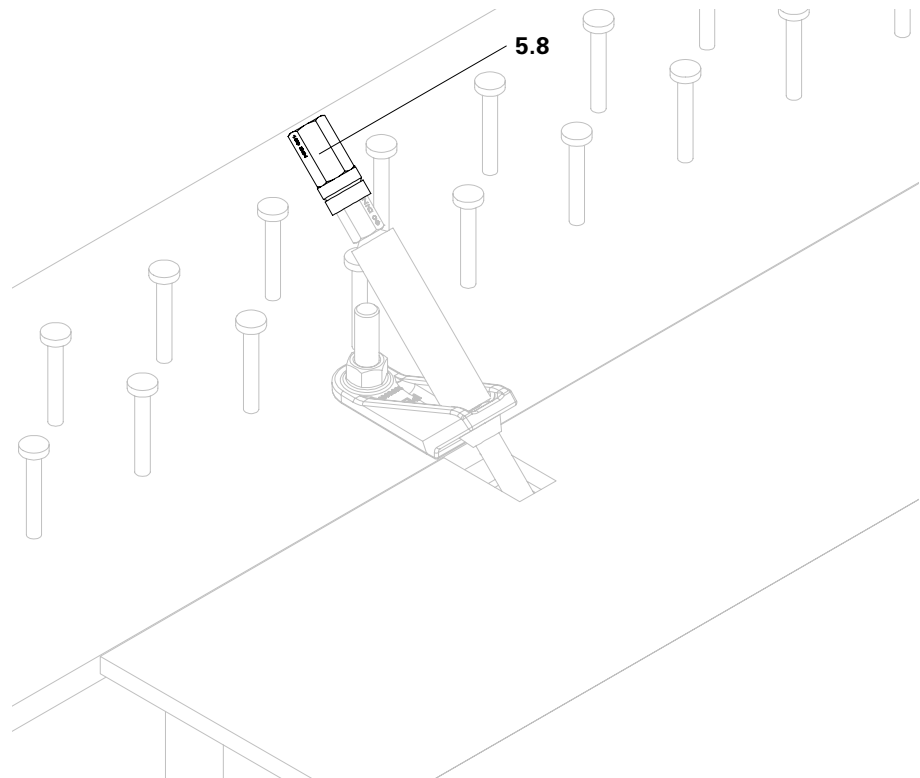

Fig. B5.03

HT-Tube

Slide the HT-Tube (5.9) over the Pipe Insulation PE 28 x 9 until it overlaps the seal ring of the tube nut and protrudes at least 80 mm over the Plug Lock VCB DW 15 (5.8). (Fig. B5.04)

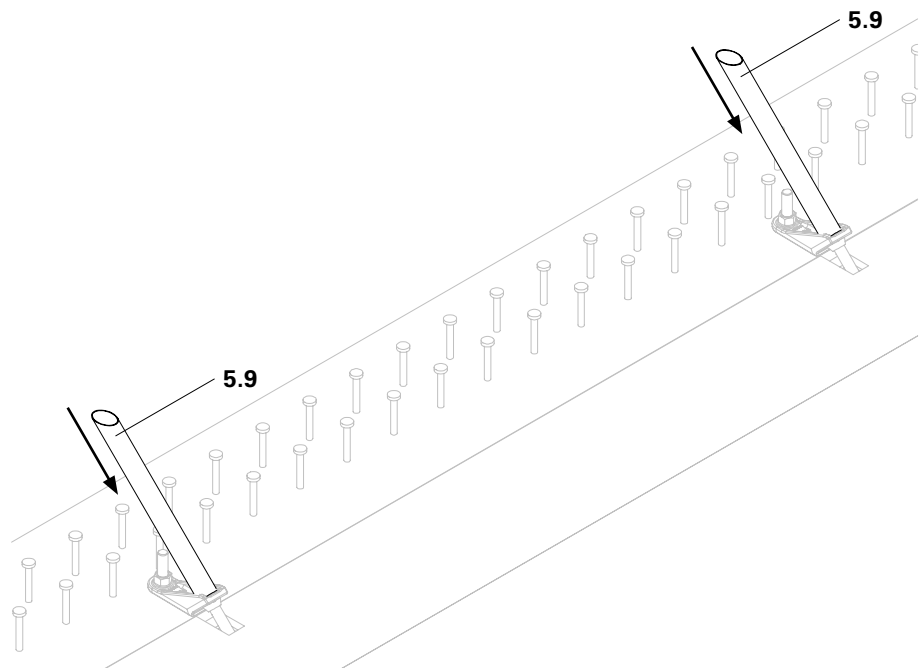

Fig. B5.04



- Mark the PE-Solid Profiles D50 with a PE-compatible and permanent signal colour. This makes it easier to mount the reinforcement and carry out the concreting.
- Pay attention during concreting that the reinforcement bars do not deform the suspension.



The PE-Solid Profile 50 must fulfil the following prerequisites:

- it must protrude at least 80 mm into the HT-Tube.
- It must be fitted with the required inclination to the carriageway surfacing.
- The cut surface of the PE-Solid Profile D50 must be approx. 5 mm below the level of the carriageway slab.

PE-Solid Profile

Seal the HT-Tube (5.9) with PE-Solid Profile D50 (5.10) by sliding into position. (Fig. B5.05)

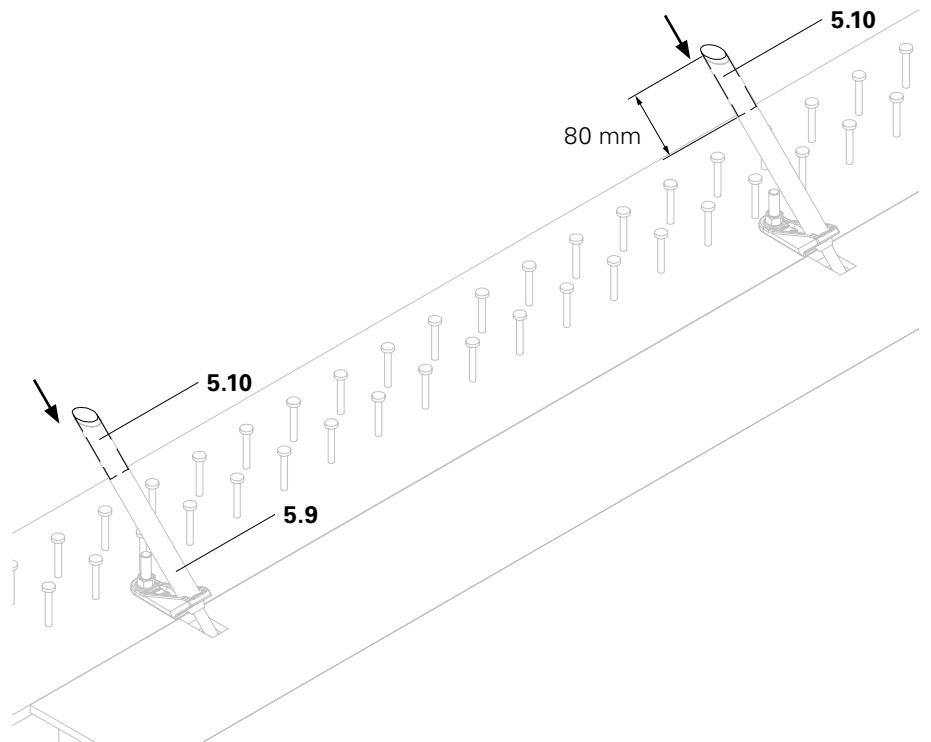

Fig. B5.05



- The suspension of the cantilever bracket does not protrude over the top edge of the superstructure concrete slab but is positioned underneath this.
- The elimination of any obstacles allows the use of a vibrating beam during concreting.
- If demanded by the required surface quality, a mobile smoothing machine can be used for machining and smoothing the concrete surface.

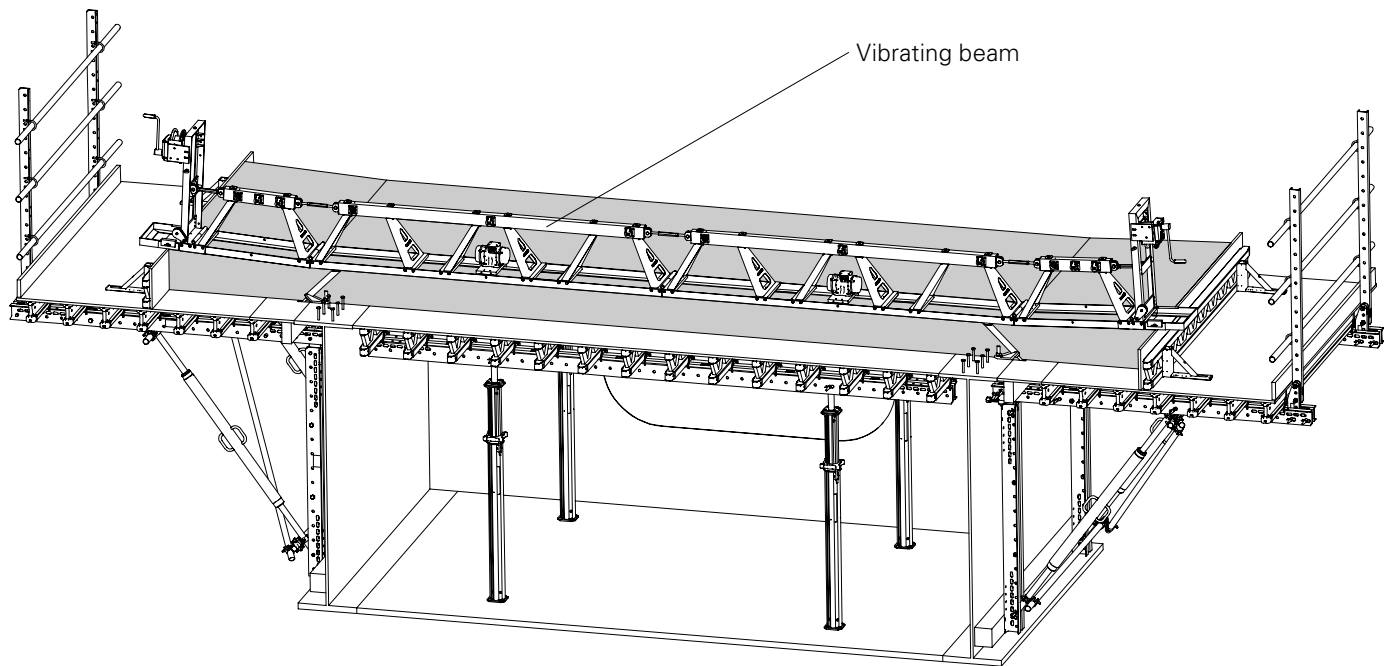

Fig. C1.01

D1 Breaking open the anchor points



Risk of injury from concrete splinters during removal. Wear personal protective equipment.



Breaking open

Carefully break open the anchor points using suitable tools until the PE-Solid Profile D50 (5.10) can be accessed. (Fig. D1.01a)

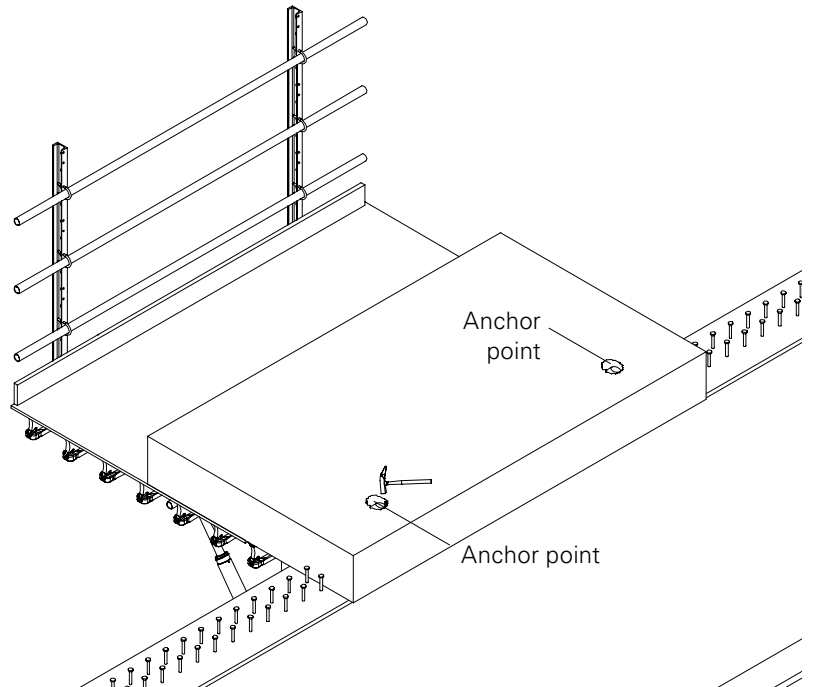

Fig. D1.01

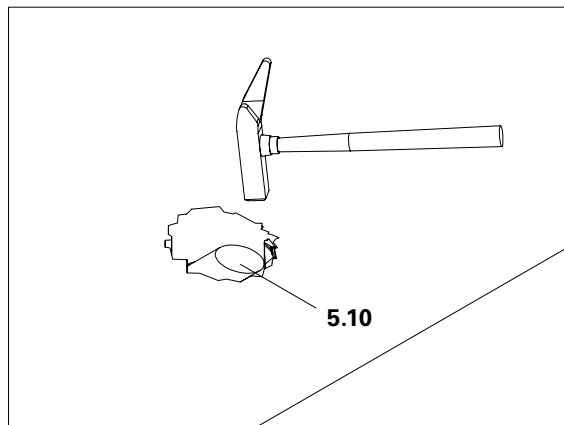

Fig. D1.01a



Do not loosen the tube nuts before the cantilever bracket is secured with the Table Lifting Fork 1 t / 5.0 m.

Dismantling

Remove the PE-Solid Profile D50 (5.10) from the released HT-Tube (5.9) by hand. (Fig. D2.01)

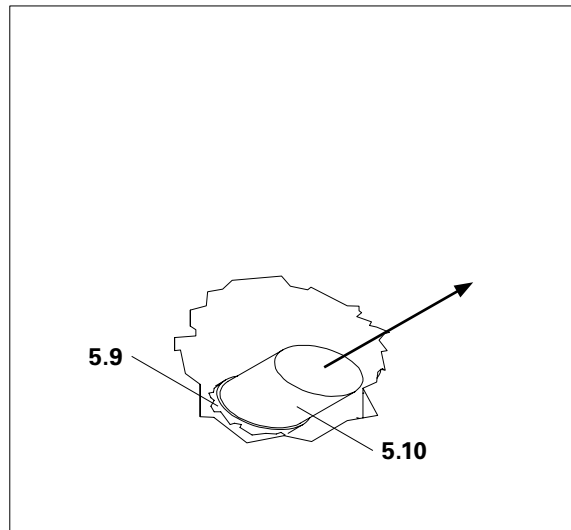

Fig. D2.01

Pos.	Designation	Pieces
5.11	Multi Tool VCB	1x

With magnet

Pull Plug Lock VCB DW 15 (5.8) with the magnetic Multi Tool VCB (5.11) downwards from the Tie Rod DW 15 (5.2) and remove from the HT-Tube (5.9). (Fig. D2.02)

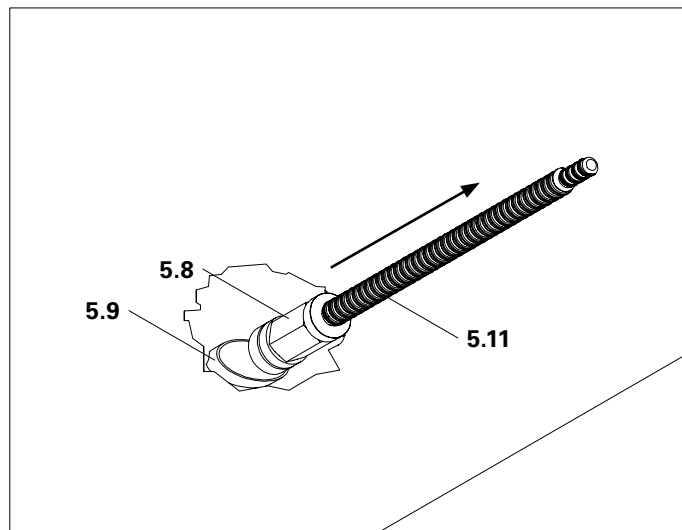

Fig. D2.02

Without magnet

If the Plug Lock VCB DW 15 (5.8) cannot be pulled out of the HT-Tube with the magnet (5.11.1), alternatively the other end of the Multi Tool VCB (5.11) can be used.

1. Screw in the thread end for a depth of two threads into the Plug Lock VCB DW 15 (5.8).
2. Remove the Plug Lock VCB DW 15 (5.8) from the HT-Tube (5.9). (Fig. D2.03)

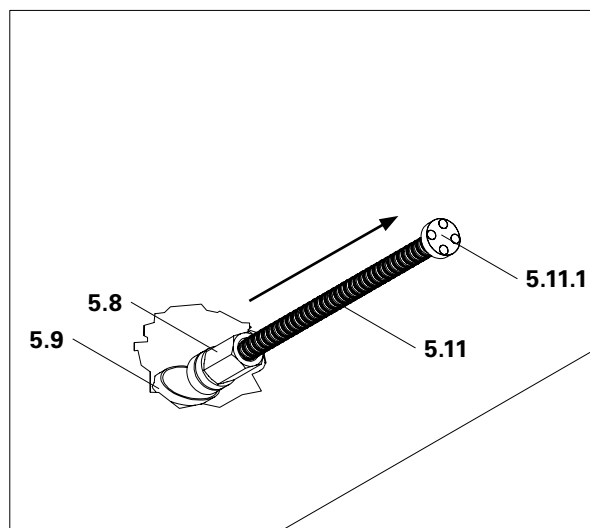

Fig. D2.03

D3 Loosening and removing the cantilever bracket



Cantilever bracket must be secured against falling to the ground or sliding.

Securing the cantilever bracket

Position the Table Lifting Fork 1 t / 5.0 m (6.1) under the cantilever bracket, and then support the cantilever bracket. (Fig. D3.01)

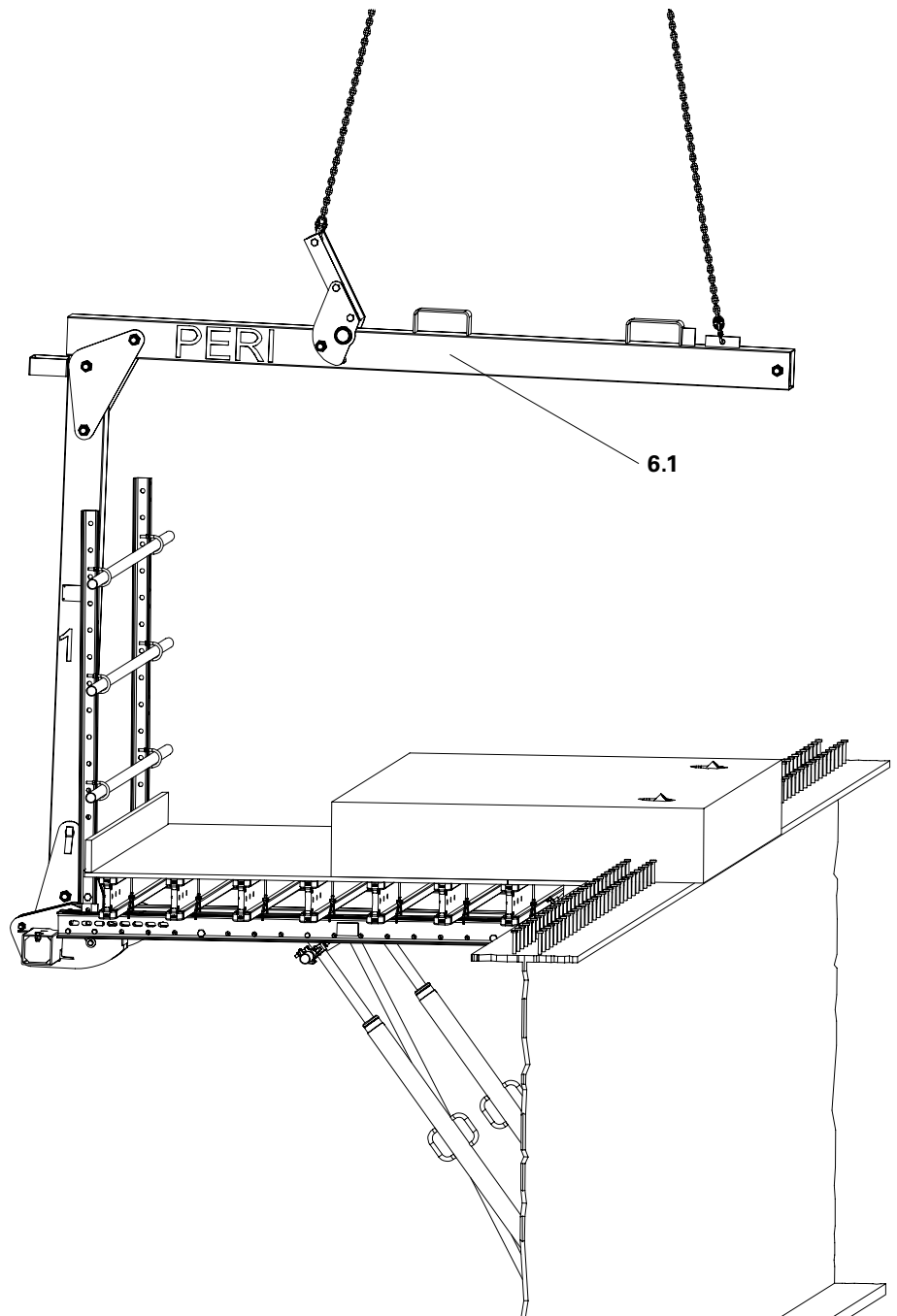

Fig. D3.01

D3 Loosening and removing the cantilever bracket



- Cantilever bracket must be secured against falling to the ground or sliding.
- Do not stand on the cantilever bracket.
- Watch out for unsecured building edges.
- Wear PPE against falling.



When the two tube nuts are unscrewed, the suspensions of the cantilever bracket are detached from the structure and the Table Lifting Fork 1 t / 5.0 m then carries the load of the cantilever bracket weight.

Removing the tube nut

1. Use a Socket Wrench SW 30, an extension and a ratchet wrench to unscrew the tube nut from the Tie Rod DW 15.
(Fig. D3.02)

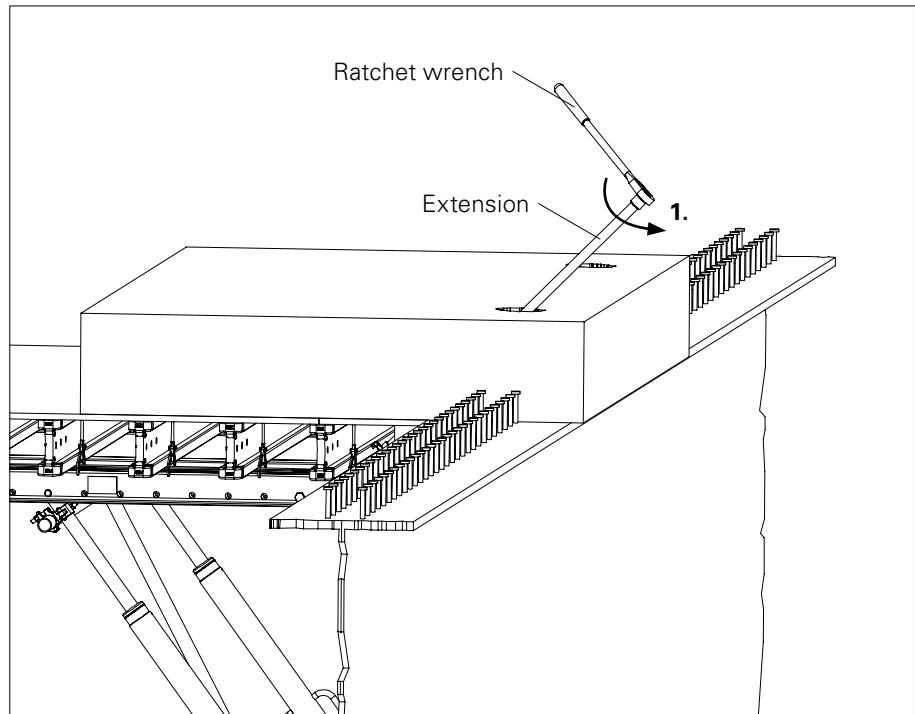

Fig. D3.02



From this point on, the cantilever bracket is no longer connected to the structure.

2. Turn the Multi Tool VCB (5.11) in the tube nut.
3. Remove the tube nut, which has been released from the Tie Rod DW 15 (5.2), from the HT-Tube (5.9) with the aid of the screwed in Multi Tool VCB (5.11). (Fig. D3.03)

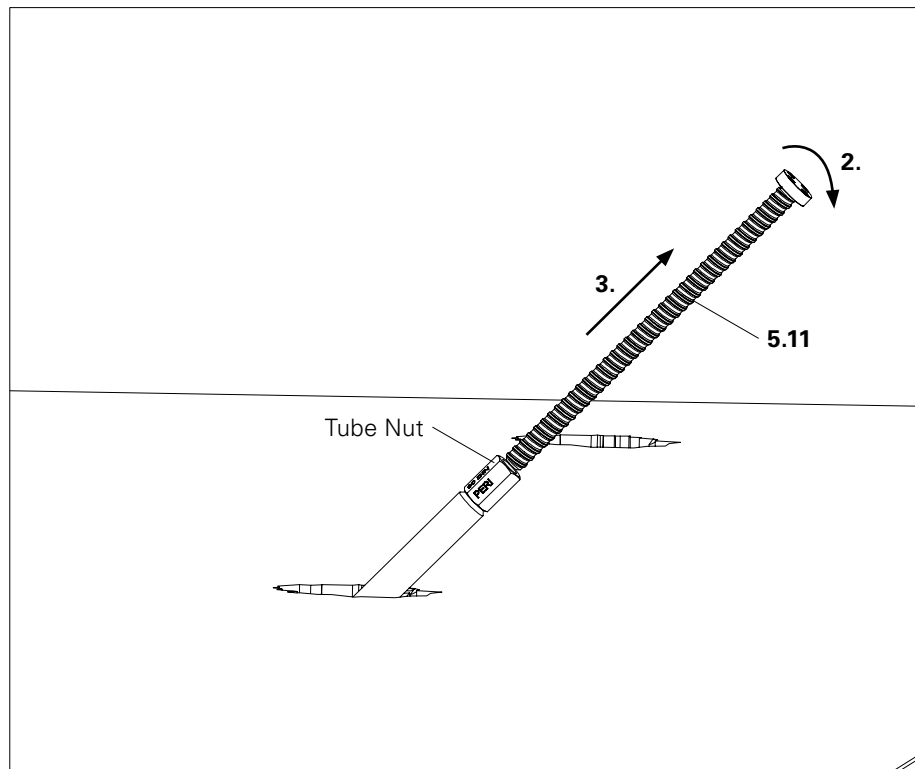

Fig. D3.03

D3 Loosening and removing the cantilever bracket



- Secure the cantilever bracket against falling to the ground as well as slipping during the moving procedure.
- Do not stand under suspended loads.

Moving the cantilever bracket

1. Remove the cantilever bracket from the building using the Table Lifting Fork 1 t / 5.0 m (6.1). (Fig. D3.04)
2. Transport the cantilever bracket to the next casting segment.

or

3. Position on the assembly construction for dismantling. (See Section A6)

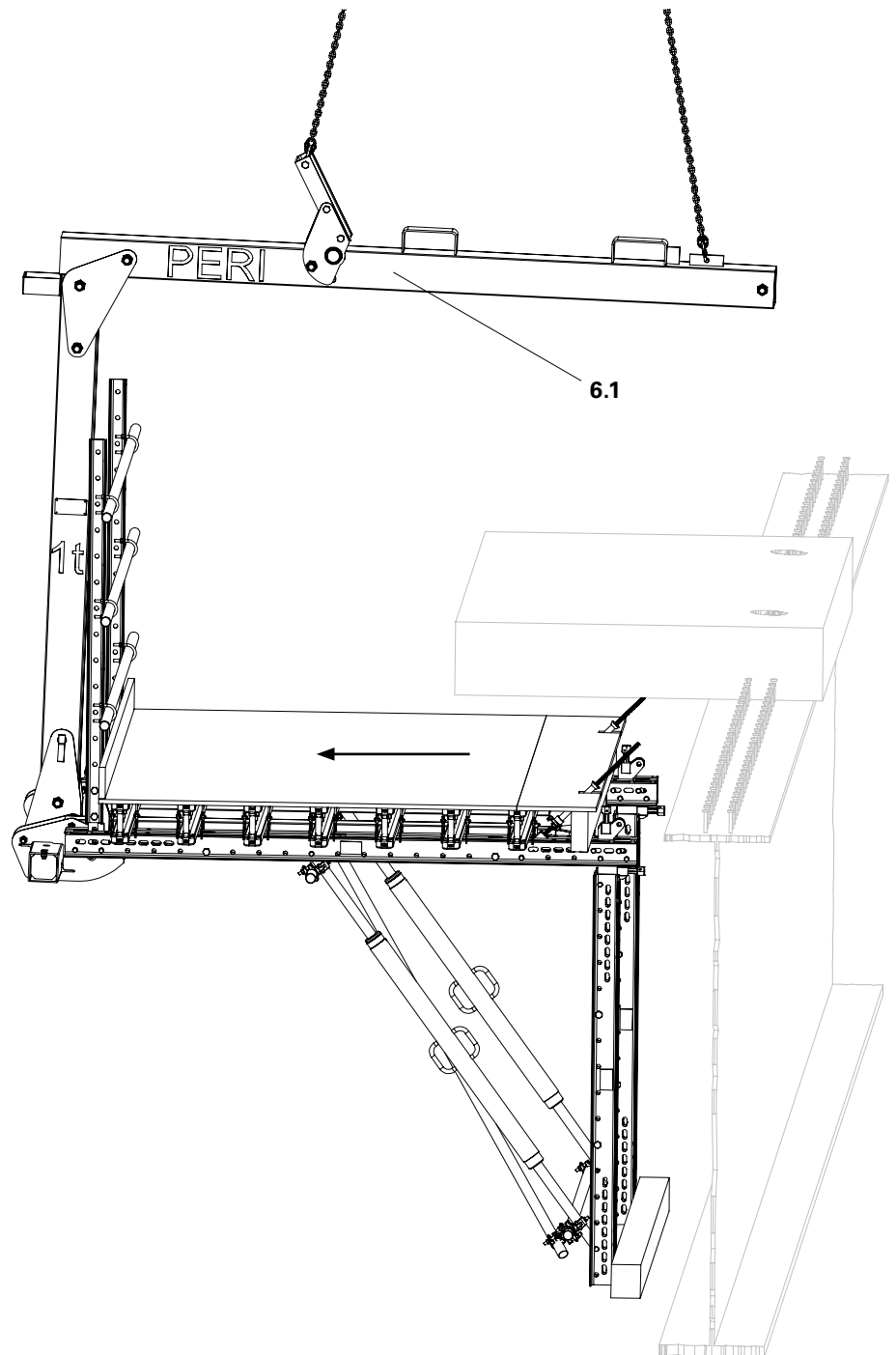

Fig. D3.04

D3 Loosening and removing the cantilever bracket



- After positioning, secure the cantilever bracket against falling to the ground as well as slipping.
- Do not stand under suspended loads.

Setting down the cantilever bracket

Set down the cantilever bracket on the assembly trestle using the Table Lifting Fork 1 t / 5.0 m (6.1). (Fig. D3.05)

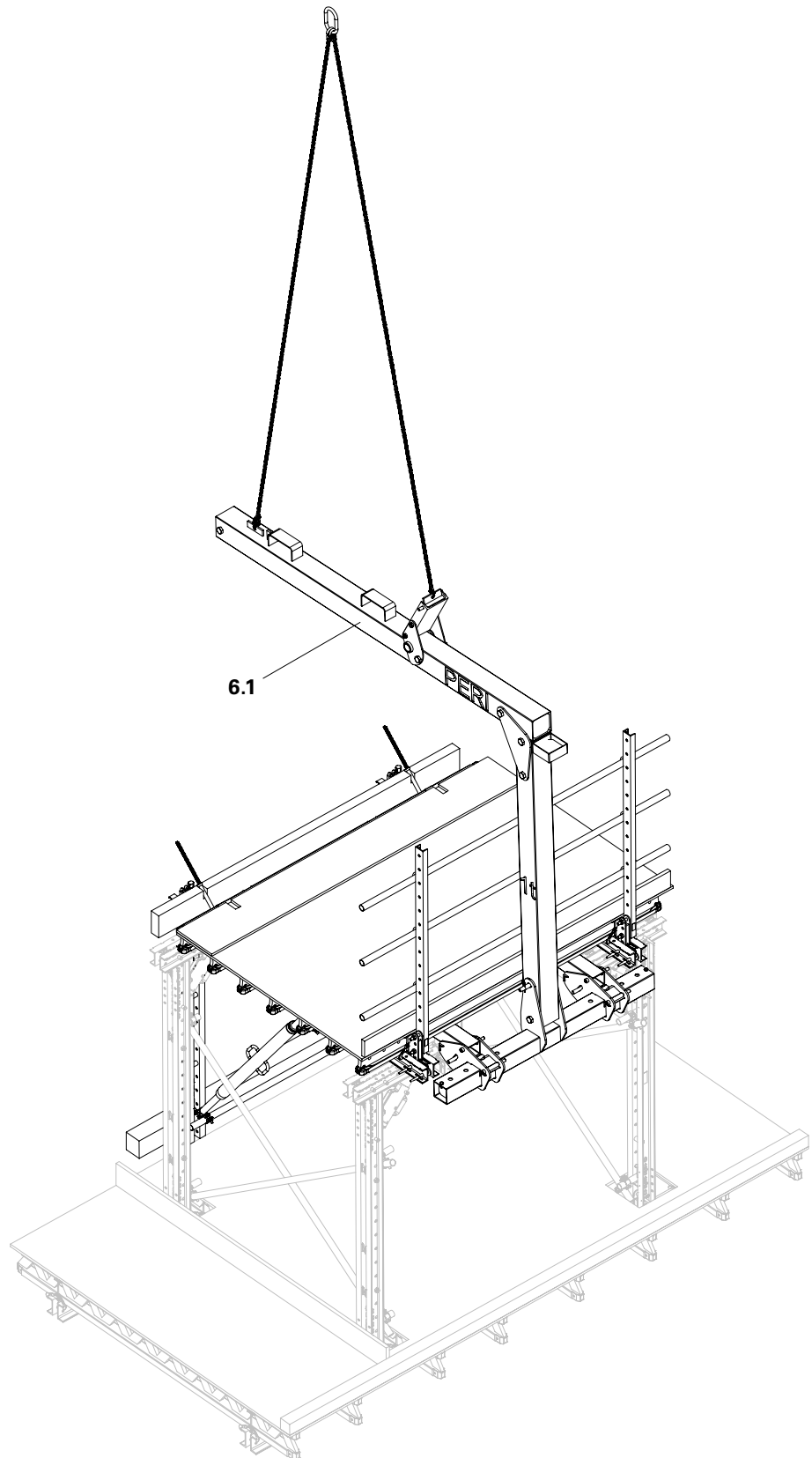

Fig. D3.05



- Watch out for falling components.
- Before dismantling, ensure all components and materials have been removed.



Dismantling

1. Remove timbers from Steel Waler SRU U120 (1.1).
2. Remove the diagonally installed Steel Scaffold Tube \varnothing 48.3 x 3.2 (2.3) and Swivel Couplings DK 48/48 (2.9). (Fig. D4.01)
3. Remove the horizontal Steel Scaffold Tubes \varnothing 48.3 x 3.2 (2.3) and Standard Couplers NK 48/48 (2.8). (Fig. D4.02)
4. Remove the Heavy-Duty Spindles SLS (1.3). (Fig. D4.01)
5. Remove the vertical Steel Waler SRU U120 (1.1). (Fig. D4.02)
6. Remove the Waler Jack with Connector VARIOKIT (1.2) on the front side. (Fig. D4.02)

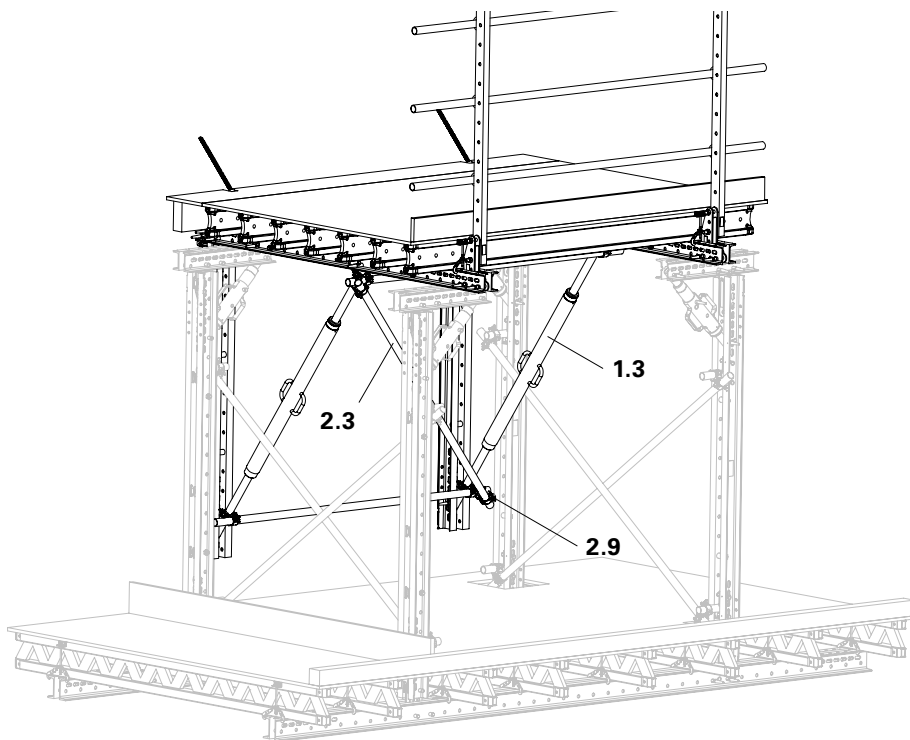

Fig. D4.01

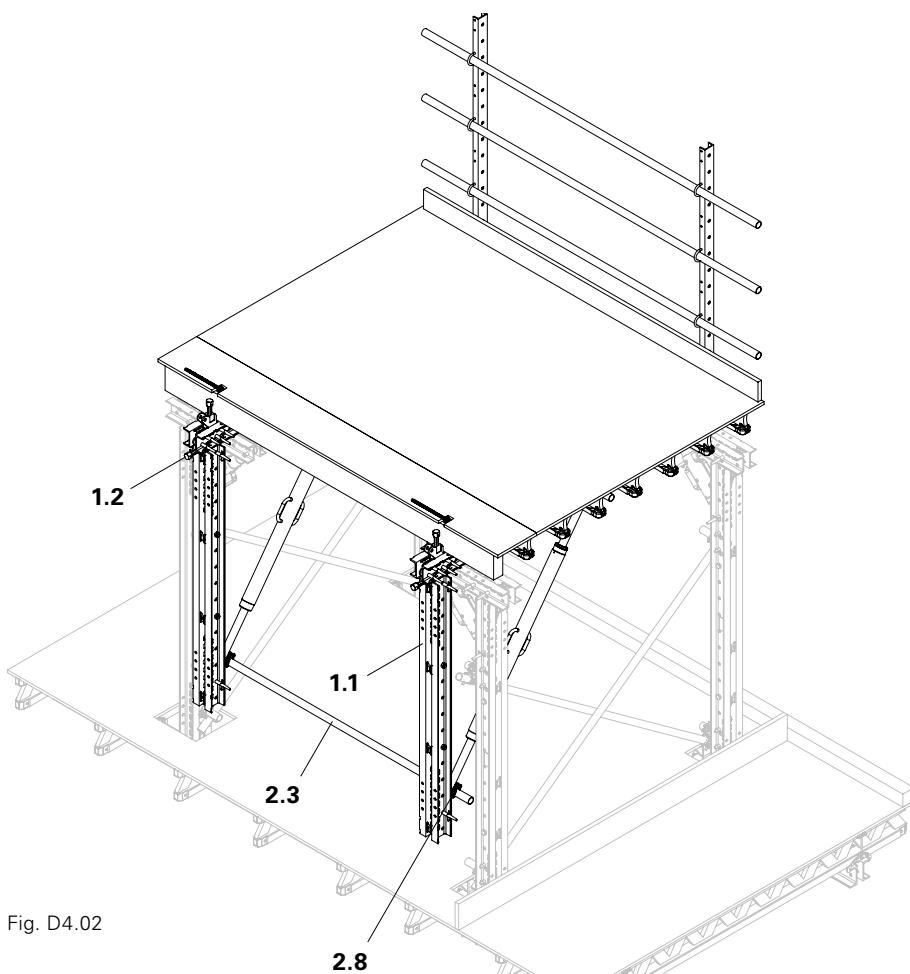

Fig. D4.02



The dismantled cantilever bracket can be positioned without the use of a crane on the previously erected assembly area with the help of construction site lifting equipment.

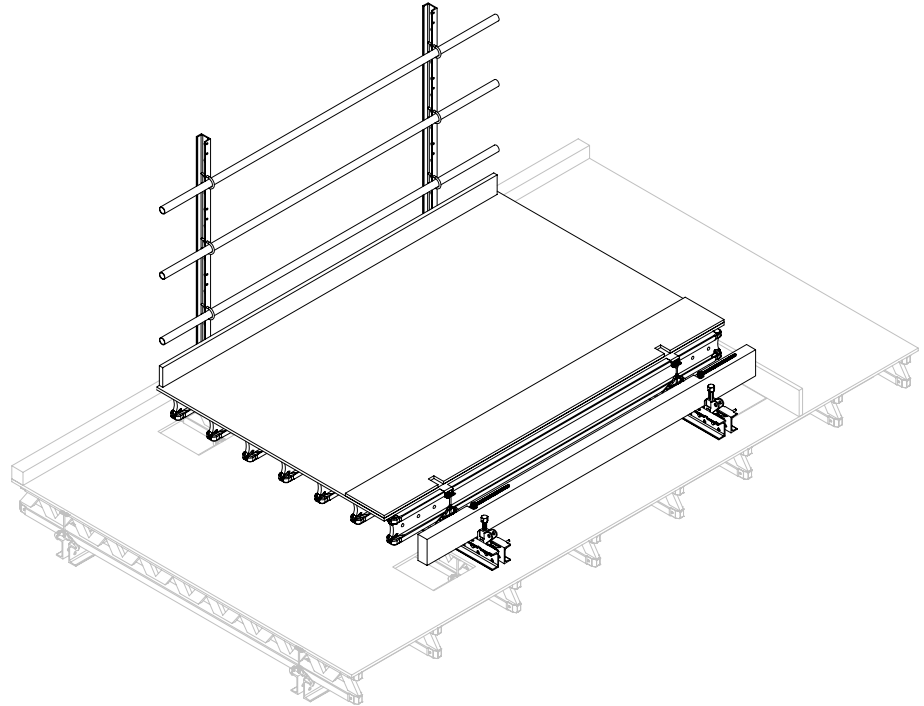

Fig. D4.03

Dismantling

1. Remove Steel Scaffold Tube \varnothing 48.3 x 3.2 (2.3), Clamp A64 DIN 3570 M12 (2.4) and Nuts M12.
2. Remove toe board (2.10).
3. Remove planking (2.7).
4. Remove Guardrail Posts RCS/SRU 184 (2.2).
5. Remove Corner Connector SRU VARIOKIT (2.1). (See Section A3 Platform and A4 Formwork)
6. Remove the Waler Jack with Connector VARIOKIT (1.2).
7. Remove the Device Suspension Lock VCB DW 15 (5.7).
8. Remove the Girder VT 20K (2.5) and timbers by removing the Hook Strap HBU (2.6) and Hex. Wood Screws.

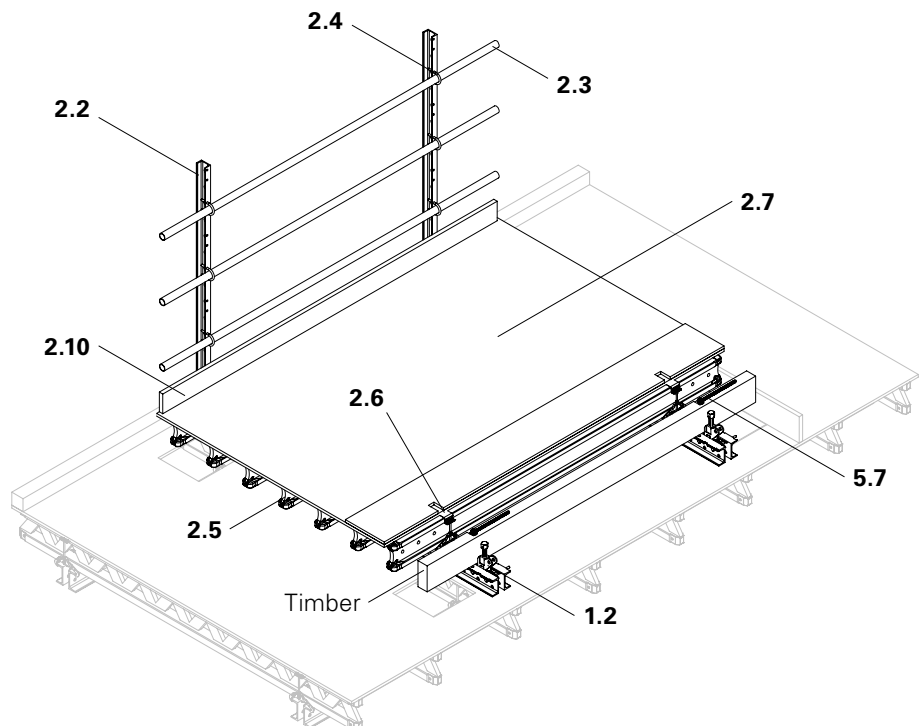

Fig. D4.04

VARIOKIT VCB Cantilever Bracket



Item no.	Weight kg
115616	3.210

Waler Jack with Connector VARIOKIT

Used as connector part and adjustable compression point.

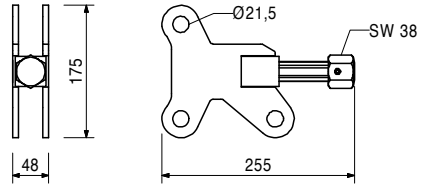
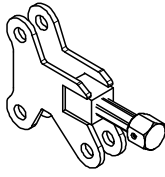

115623	5.060
--------	-------

Connector SRU VARIOKIT

For a rigid connection of Steel Walers SRU.

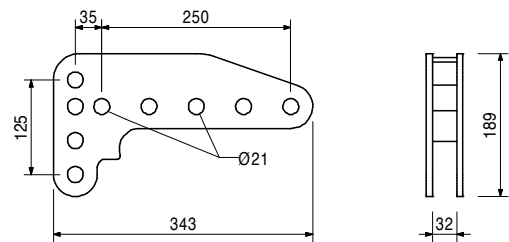
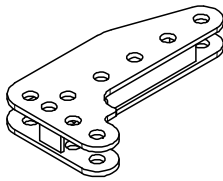

104031	0.462
018060	0.030

Accessories

Fitting Pin Ø 21 x 120
Cotter Pin 4/1, galv.

110756	7.980
--------	-------

Tie Yoke Head SRU

For mounting in the Steel Waler SRU. Suitable for Tie Rod DW 15.

Complete with

- 2 pc. 105400 Pin Ø 20 x 140, galv.
- 2 pc. 018060 Cotter Pin 4/1, galv.
- 2 pc. 770013 Split Pin ISO 8752 8 x 70, galv.
- 1 pc. 110755 Tie Yoke SRU

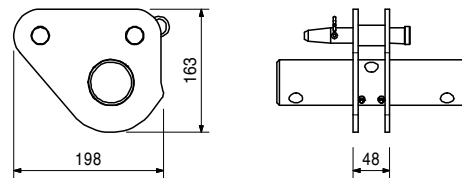
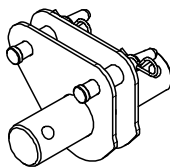

116532	1.890
--------	-------

Tie Yoke VARIOKIT Ø 22 / DW 15

For assembling in Steel Waler SRU.

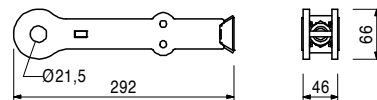
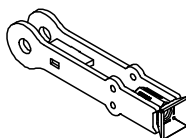

VARIOKIT VCB Cantilever Bracket



Item no.	Weight kg
115808	2.360

Anchor Bracket VARIOKIT
Lost part for brackets.

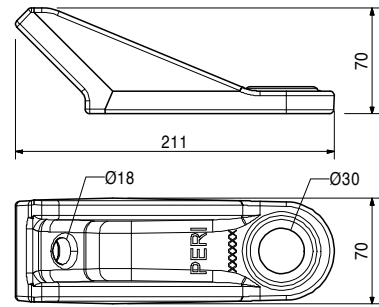
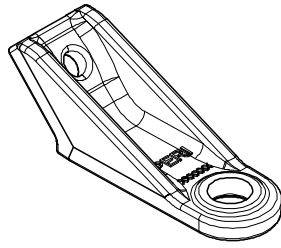

030030	1.440
030050	0.000

Tie Rod DW 15
Tie Rod DW 15, spec. length
Cutting Cost Tie Rod DW 15, B 15

Note
Non-weldable! Take official approval into consideration!

Technical Data
Permissible tension force 90 kN.

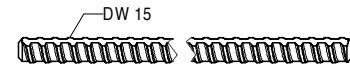
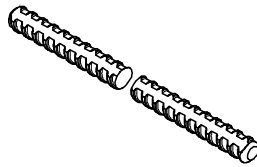

030550	0.233
--------	-------

Hex. Nut DW 15 SW 30/50, weldable
For anchoring with Tie Rod DW 15 and B 15.

Note
Weldable!
Technical Data
Permissible load 90 kN.

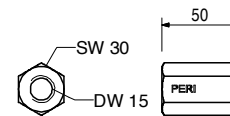

110797	2.790
--------	-------

Tension Rod 15 SRU, l = 1.50 m
Suitable for Strut SRU l = 1.65 - 2.40 m,
item no. 110765 and the Spacer Tube DW 15-550
VARIOKIT.

Technical Data
Permissible load 85 kN.

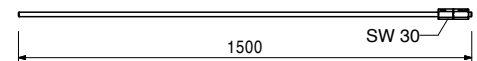
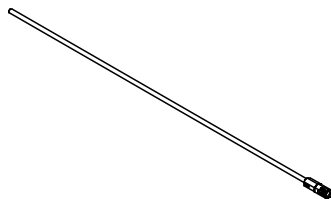

VARIOKIT VCB Cantilever Bracket



Item no.	Weight kg
115535	2.740

Spacer Tube DW 15-550 VARIOKIT
 Conical nut for anchoring to the Anchor Bracket VARIOKIT.

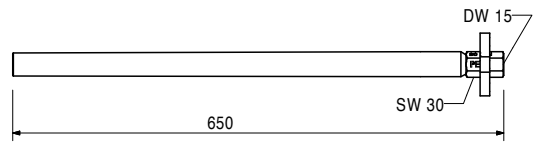
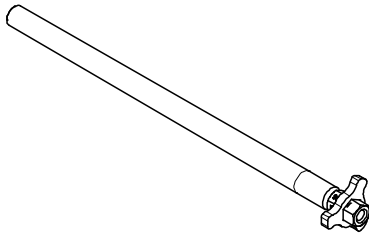

065070	1.670
--------	-------

AW Slab Stopend Angle
 For forming stopends for slabs and to form beams.

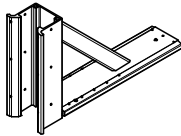

Note
 Permissible load: see PERI Design Tables.

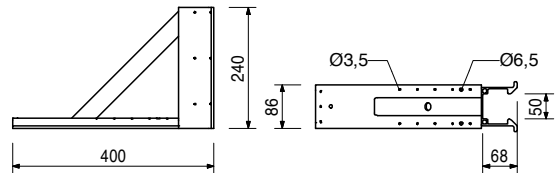

126299	0.466
--------	-------

Plastic Slab Stopend Angle

Note
 See data sheet!

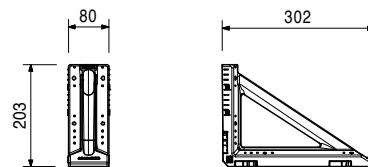
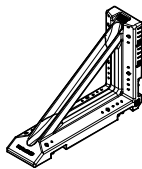

129754	1.530
--------	-------

Suspension Lock VCB DW 15

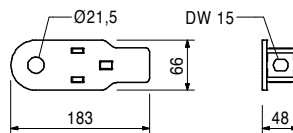
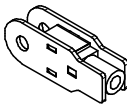

129757	1.120
--------	-------

Tube Nut VCB DW 15-25

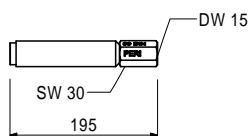
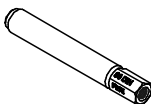

Item no.	Weight kg
129776	0.004

Seal Ring VCB

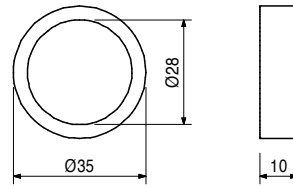
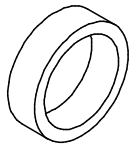

129783	0.568
--------	-------

Plug Lock Hex. Nut VCB DW 15

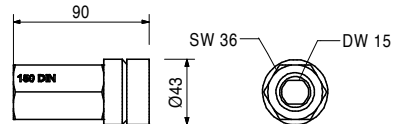
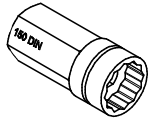

030190	0.462
--------	-------

Three Wingnut DW 15, galv.

For anchoring with Tie Rod DW 15 and B 15.

Technical Data

Permissible load 90 kN.

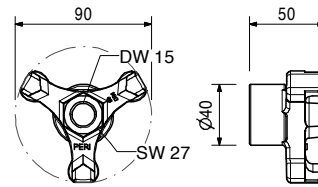

065033	0.010
--------	-------

Cone DR 22

Plastic. Suitable for Spacer Tube DR 22.

Note

Delivery unit 500 pieces.

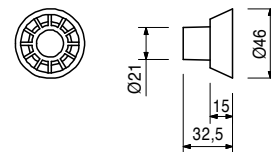

Spacer Tubes	
065027	0.359
065030	0.039
065031	0.050

Spacer Tubes

Spacer Tube rough DR 22, l = 2.00 m

Spacer Tube rough DR 22, l = 0.21 m

Spacer Tube rough DR 22, l = 0.27 m

Plastic Spacer Tube for DW 15, B 15.

L

2000

210

270

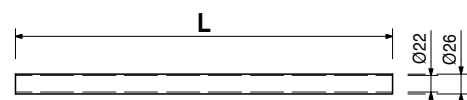
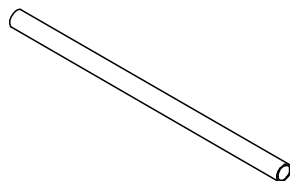

Item no.	Weight kg
065036	0.002

Plug DR 22
Plastic. Suitable for Spacer Tube DR 22.

Note
Delivery unit 1000 pieces.

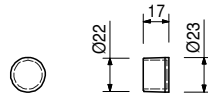

031260	1.500
031320	0.000

Concrete Spacer Tube
Concrete Spacer Tube FZR 22, l = 0.90 m
Cutting Cost Tube FZR 22
Spacer Tube made of fibre reinforced concrete for use with Tie Rod DW 15, wall thickness 9 mm, asbestos-free!

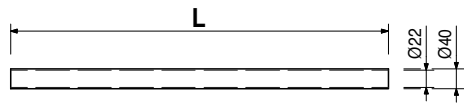
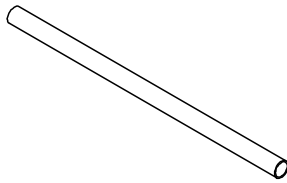

031360	0.017
--------	-------

Plug FZR 22 mm
Made of fibre reinforced concrete. Suitable for FZR 22.

Note
Delivery unit 1000 pieces.

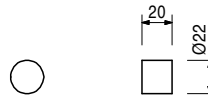

130585	1.160
--------	-------

Multi Tool VCB

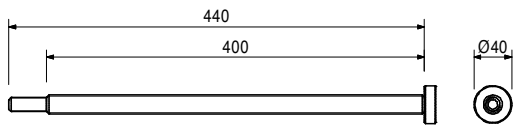
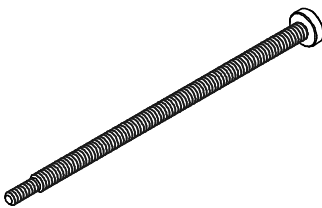

129774	0.026
--------	-------

Pipe Insulation PE 28 x 9

129775	0.285
--------	-------

HT-Tube Ø 50 x 1.8

129773	0.049
--------	-------

PE-Solid Profile Ø 50

VARIOKIT VCB Cantilever Bracket



Item no.	Weight kg
104131	3.940

Guardrail Holder SRU/SRZ

For assembling a guardrail to the Steel Walers SRU and SRZ, Profile U100 to U140.

Complete with

2 pc. 105400 Pin \varnothing 20 x 140, galv.
2 pc. 018060 Cotter Pin 4/1, galv.

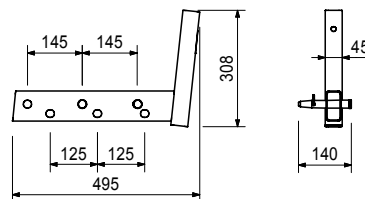
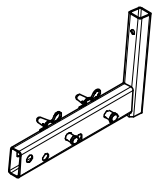

Accessories

116292	4.720
061260	6.150

Guardrail Post HSGP-2

Guardrail Post SGP

101290	5.670
--------	-------

Guardrail Holder GT 24 / VT 20

For assembling a guardrail to GT 24 and VT 20 Girders.

Complete with

1 pc. 105400 Pin \varnothing 20 x 140, galv.
1 pc. 018060 Cotter Pin 4/1, galv.

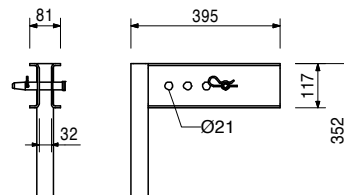
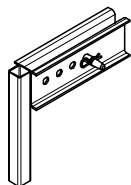

Accessories

116292	4.720
061260	6.150

Guardrail Post HSGP-2

Guardrail Post SGP

126088	4.390
--------	-------

Guardrail Post Holder Multi

For fixing of an end guardrail post on Girders GT 24, VT 20 or Timbers 80/160.

Fixing of the guardrail posts by means of Hex. Bolts M20 or Clamp A64.

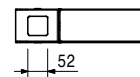
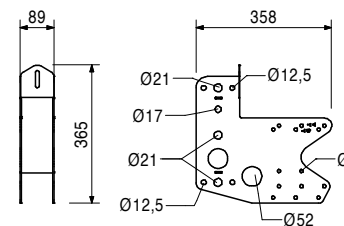
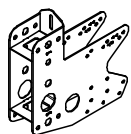

Accessories

710285	0.050
024090	0.005
024470	0.008

Bolt ISO 4014 M8 x 100-8.8, galv.

Nut ISO 4032 M8-8, galv.

TSS-Torx 6 x 60, galv.

VARIOKIT VCB Cantilever Bracket



Item no.	Weight kg
114557	7.050

Platform Beam SRU

For assembling a platform and guardrail at vertical Steel Waler SRU.

Complete with

2 pc. 104031 Fitting Pin \varnothing 21 x 120
2 pc. 018060 Cotter Pin 4/1, galv.

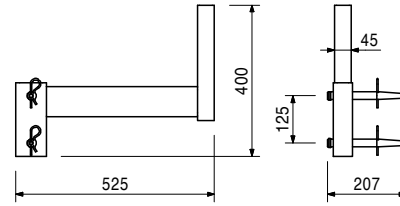
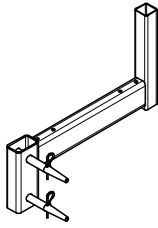

Accessories

116292	4.720
--------	-------

Guardrail Post HSGP-2

116292	4.720
--------	-------

Guardrail Post HSGP-2

As guardrail for different systems.

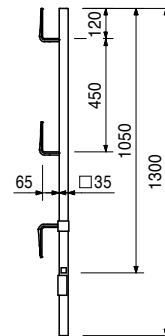

061260	6.150
--------	-------

Guardrail Post SGP

As guardrail for different systems.

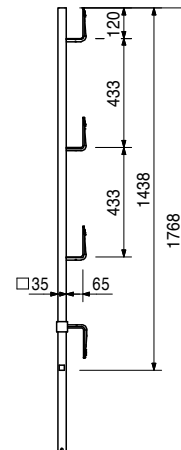

VARIOKIT VCB Cantilever Bracket



Item no.	Weight kg
019040	6.480

Guardrail Post PD 8

As guardrail for different systems. Screwed onto sub-structure.

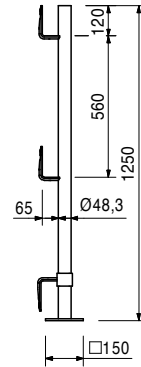

116363	0.089
--------	-------

Spacer RCS 184

Compensator between Angle Connector RCS/SRU and Guardrail Post RCS 184.

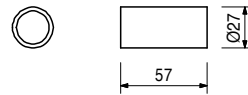

114328	16.600
--------	--------

Guardrail Post RCS/SRU 184

For assembly of the guardrail on the Platform Beam RCS/SRU or Angle Connector RCS/SRU.

Complete with

2 pc. 114727 Bolt ISO 4017 M20 x 100-8.8, galv.
2 pc. 781053 Nut ISO 7042 M20-8, galv.

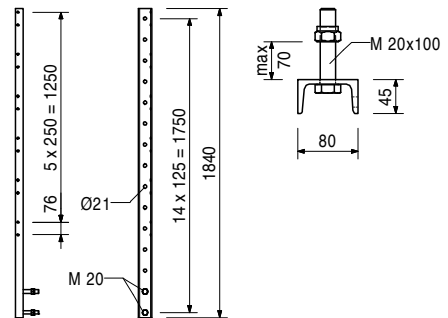

Item no.	Weight kg
109720	26.600

Guardrail Post RCS 226

For assembly of the guardrail on the main platform with RCS formwork scaffolding or as horizontal strut in the bracing.

Complete with

2 pc. 104477 Bolt ISO 4014 M20 x 120-8.8, galv.
2 pc. 781053 Nut ISO 7042 M20-8, galv.

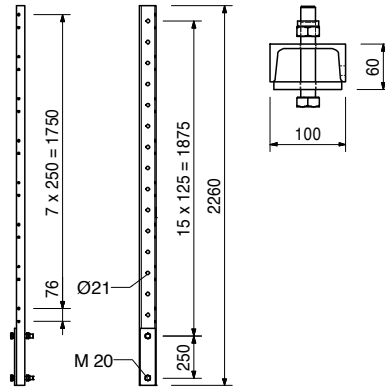

109721	40.700
--------	--------

Guardrail Post RCS 384

For assembly of the guardrail on the intermediate and finishing platforms with RCS formwork scaffolding or as horizontal strut in the bracing.

Complete with

1 pc. 104477 Bolt ISO 4014 M20 x 120-8.8, galv.
1 pc. 781053 Nut ISO 7042 M20-8, galv.

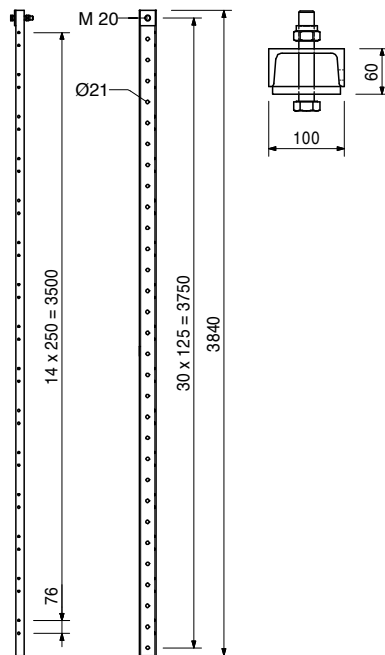

VARIOKIT VCB Cantilever Bracket



Item no.	Weight kg
109773	67.900

Guardrail Post RCS 509

For assembly of the guardrail on the intermediate and finishing platforms with RCS formwork scaffolding or as horizontal strut in the bracing.

Complete with

- 1 pc. 104477 Bolt ISO 4014 M20 x 120-8.8, galv.
- 1 pc. 781053 Nut ISO 7042 M20-8, galv.

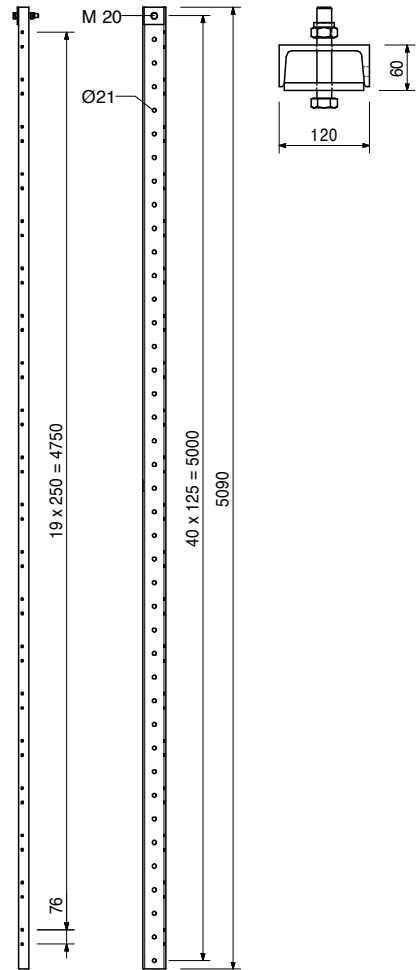

Item no.	Weight kg
126495	24.200

Guardrail Post RCS-MP

For fixation of the side protection on Material Platforms RCS-MP with horizontal Climbing Rail RCS.

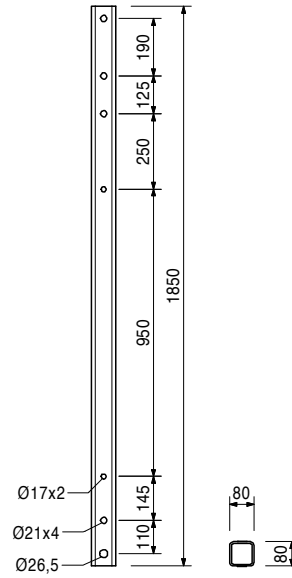

104477	0.300
781053	0.065
104031	0.462
018060	0.030

Accessories

Bolt ISO 4014 M20 x 120-8.8, galv.

Nut ISO 7042 M20-8, galv.

Fitting Pin Ø 21 x 120

Cotter Pin 4/1, galv.

110296	0.220
--------	-------

Clamp A64 DIN 3570 M12, galv.

For assembling Scaffold Tubes Ø 48 or Ø 60.

Note

Wrench size SW 19.

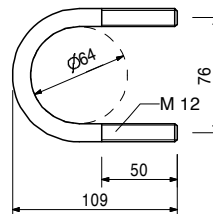
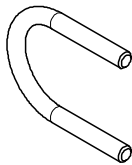

710330	0.017
--------	-------

Accessories

Nut ISO 4032 M12-8, galv.

VARIOKIT VCB Cantilever Bracket

Item no.	Weight kg		L
075100	5.300	Girders GT 24	918
075120	7.100	Girder GT 24, l = 0.90 m	1214
075150	8.900	Girder GT 24, l = 1.20 m	1510
075180	10.600	Girder GT 24, l = 1.80 m	1806
075210	12.400	Girder GT 24, l = 2.10 m	2102
075240	14.200	Girder GT 24, l = 2.40 m	2398
075270	15.900	Girder GT 24, l = 2.70 m	2694
075300	17.700	Girder GT 24, l = 3.00 m	2990
075330	19.500	Girder GT 24, l = 3.30 m	3286
075360	21.200	Girder GT 24, l = 3.60 m	3582
075390	23.000	Girder GT 24, l = 3.90 m	3878
075420	24.800	Girder GT 24, l = 4.20 m	4174
075450	26.600	Girder GT 24, l = 4.50 m	4470
075480	28.300	Girder GT 24, l = 4.80 m	4766
075510	30.100	Girder GT 24, l = 5.10 m	5062
075540	31.900	Girder GT 24, l = 5.40 m	5358
075570	33.600	Girder GT 24, l = 5.70 m	5654
075600	35.400	Girder GT 24, l = 6.00 m	5950

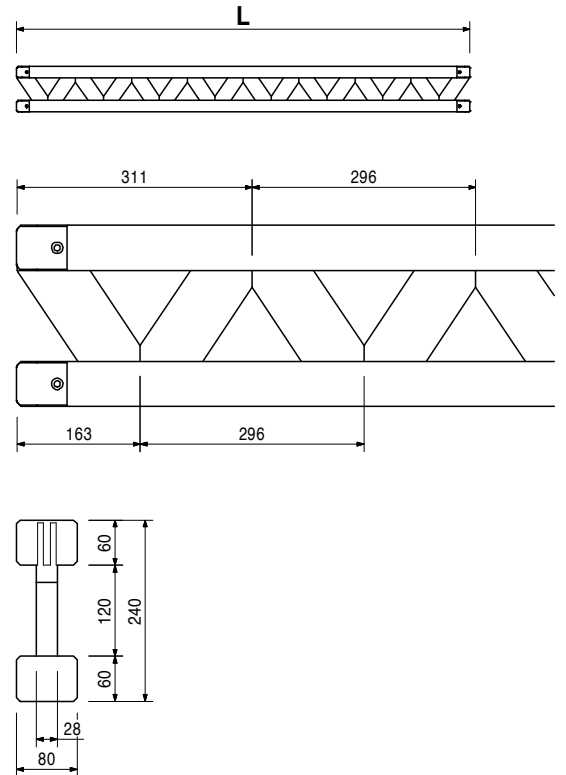
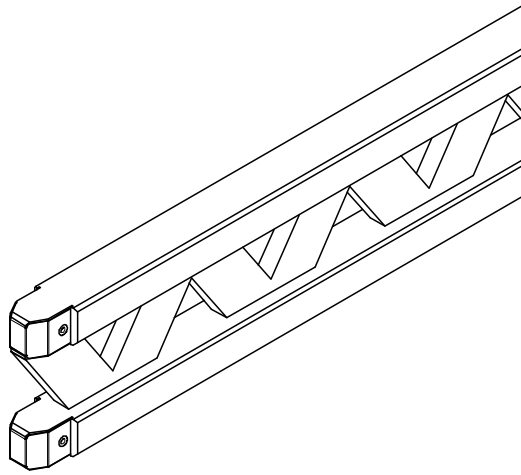

VARIOKIT VCB Cantilever Bracket



Item no.	Weight kg		L
		Girder VT 20K with Steel Cap	
074990	8.560	Girder VT 20K, l = 1.45 m	1445
074905	12.700	Girder VT 20K, l = 2.15 m	2150
074910	14.460	Girder VT 20K, l = 2.45 m	2450
074890	15.640	Girder VT 20K, l = 2.65 m	2650
074920	17.110	Girder VT 20K, l = 2.90 m	2900
074930	19.470	Girder VT 20K, l = 3.30 m	3290
074940	21.240	Girder VT 20K, l = 3.60 m	3590
074950	23.010	Girder VT 20K, l = 3.90 m	3890
074960	26.550	Girder VT 20K, l = 4.50 m	4490
074970	28.910	Girder VT 20K, l = 4.90 m	4900
074980	34.810	Girder VT 20K, l = 5.90 m	5900
074900	0.000	Cutting Cost VT Girder	

Universal formwork girder made of wood.

Note
The girder fulfils all requirements of DIN EN 13377 class P20 (Declaration of Conformity).

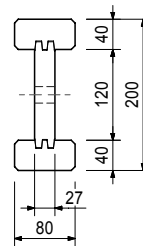
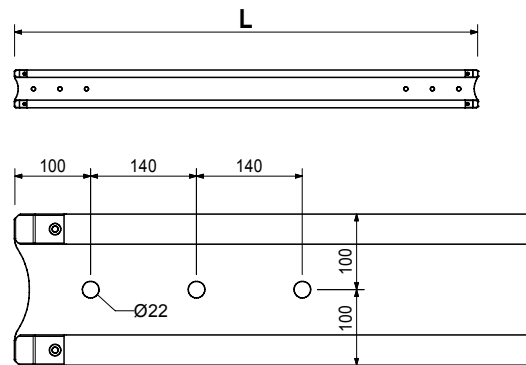
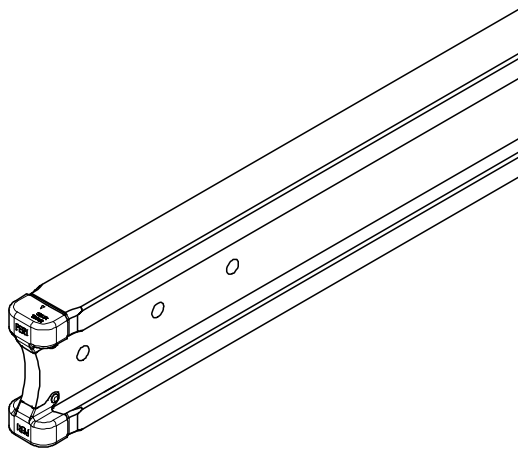

024070	0.691	Hook Strap HB 24-100/120, galv. For fixing GT 24 Girders to Steel Walers SRZ, SRU and BR: U100 – U120.
--------	-------	--

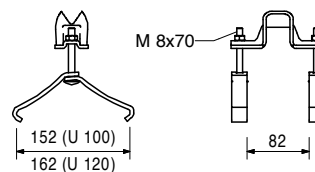
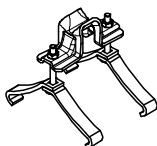

VARIOKIT VCB Cantilever Bracket



Item no.	Weight kg
024080	0.735

Hook Strap HB 24-140/160, galv.

For fixing GT 24 Girders to Steel Walers SRZ, SRU and BR: U140 – U160.

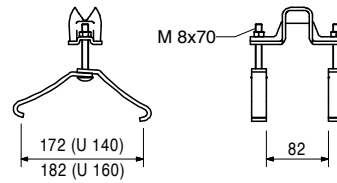
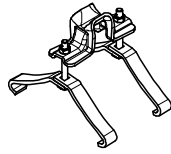

104931	0.865
103845	0.893

Hook Straps Uni

Hook Strap Uni HBU 20-24

Hook Strap Uni HBU 24-28

For fixing GT 24 Girders or VT 20 Girders to Steel Walers SRZ and SRU Profiles U100 – U140.

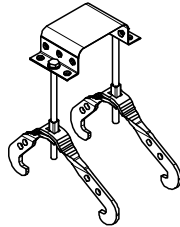

Note

The girders can be mounted at right-angles or diagonally to the steel walers and also outside of the nodes.

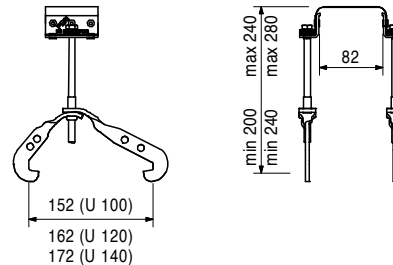

024540	0.005
--------	-------

Accessories

TSS-Torx 6 x 40, galv.

104930	0.887
104096	0.912

Hook Straps Uni Double

Hook Strap Uni Double HBUD 20-24

Hook Strap Uni Double HBUD 24-28

For fixing two GT 24 Girders or VT 20 Girders to SRZ Steel Walers and SRU Profiles U100 – U140.

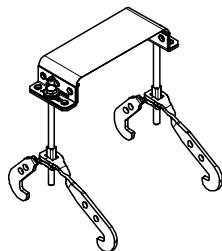

Note

The girders can be mounted at right-angles or diagonally to the steel walers and also outside of the nodes.

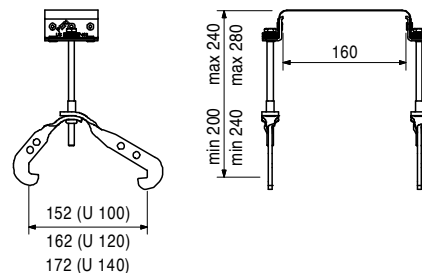

VARIOKIT VCB Cantilever Bracket



Item no.	Weight kg
024860	0.616

Hook Strap HB 24 QB 150, galv.

For fixing GT 24 Girders independent from girder node and timber beams to Steel Walers SRZ, SRU and BR: U100 – U120.

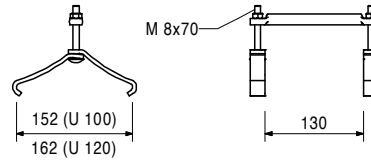
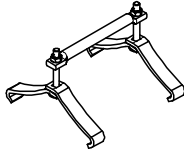

024600	0.907
--------	-------

Girder Claw HB

For mounting the GT 24 Edge Girder on the Steel Waler SRZ and SRU Profile U100 – U120.

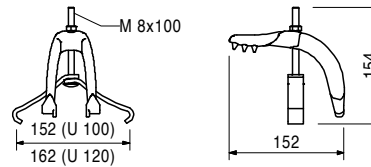
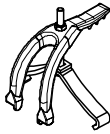

024640	0.923
--------	-------

Quick Str. Hook Strap 24-100/140, galv.

For fixing GT 24 Girders to Steel Waler SRZ, SRU, Profile U100 – U140 outside of the girder nodes.

Note

Girders fixed in position with the Quick Strap must be specially screwed to the formlining when using crane lifting gears.

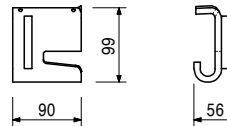
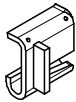

024630	0.742
--------	-------

Fix Strap U100 – U120, galv.

For fixing the GT 24 Girder in the VARIO Corner.

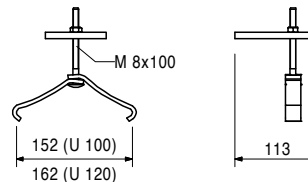
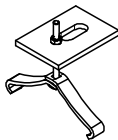

VARIOKIT VCB Cantilever Bracket



Item no. Weight kg

Item no.	Weight kg	Steel Waler Universal SRU U120	L
103868	18.100	Steel Waler Universal SRU U120, l = 0.72 m	722
103871	24.200	Steel Waler Universal SRU U120, l = 0.97 m	972
103874	30.900	Steel Waler Universal SRU U120, l = 1.22 m	1222
103877	38.100	Steel Waler Universal SRU U120, l = 1.47 m	1472
103886	44.700	Steel Waler Universal SRU U120, l = 1.72 m	1722
103889	52.000	Steel Waler Universal SRU U120, l = 1.97 m	1972
103898	58.600	Steel Waler Universal SRU U120, l = 2.22 m	2222
103892	65.600	Steel Waler Universal SRU U120, l = 2.47 m	2472
103929	72.000	Steel Waler Universal SRU U120, l = 2.72 m	2722
103903	81.000	Steel Waler Universal SRU U120, l = 2.97 m	2972
103906	92.600	Steel Waler Universal SRU U120, l = 3.47 m	3472
103915	106.000	Steel Waler Universal SRU U120, l = 3.97 m	3972
103918	119.000	Steel Waler Universal SRU U120, l = 4.47 m	4472
103922	135.000	Steel Waler Universal SRU U120, l = 4.97 m	4972
103925	146.000	Steel Waler Universal SRU U120, l = 5.47 m	5472
103928	159.000	Steel Waler Universal SRU U120, l = 5.97 m	5972

Universal Steel Waler Profile U120 used as waling for girder wall formwork and for diverse special applications. With adjustable spacers.

Note

Permissible load: see PERI Design Tables.

Technical Data

U120: $W_y = 121.4 \text{ cm}^3$, $I_y = 728 \text{ cm}^4$.

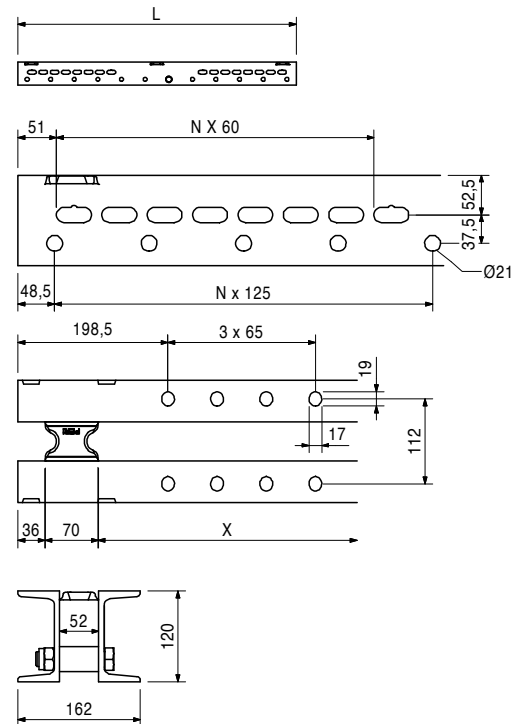
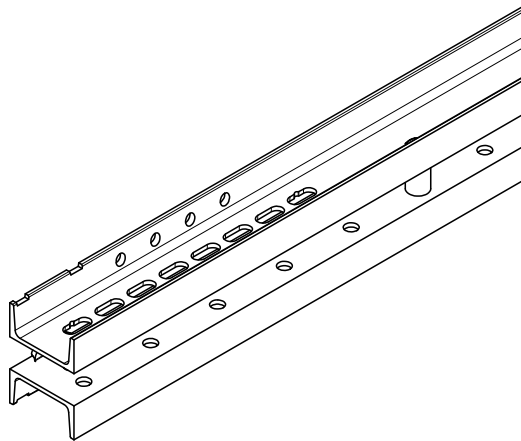

104027 7.610

Extension VARIO 24 U120

For assembly on Steel Waler SRU.

Complete with

4 pc. 710252 Bolt ISO 4017 M16 x 50-8.8, galv.

4 pc. 104024 Nut ISO 7040 M16-8, galv.

4 pc. 710880 Washer DIN 434 18, galv.

Technical Data

U120: $W_y = 121.4 \text{ cm}^3$, $I_y = 728 \text{ cm}^4$.

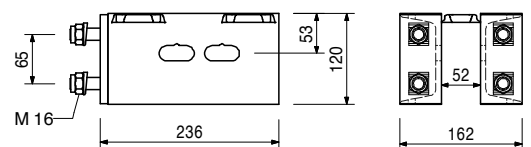
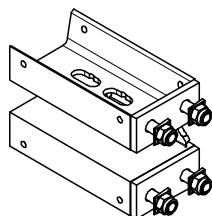

VARIOKIT VCB Cantilever Bracket



Item no.	Weight kg		A	min. L	max. L
111035	12.100	Heavy Duty Spindles SLS	344	400	800
101773	14.700	Heavy Duty Spindle SLS 40/80	746	800	1400
101774	18.200	Heavy Duty Spindle SLS 100/180	946	1000	1800
101776	24.700	Heavy Duty Spindle SLS 140/240	1346	1400	2400
101778	32.100	Heavy Duty Spindle SLS 200/300	1944	2000	3000
101779	38.300	Heavy Duty Spindle SLS 260/360	2544	2600	3600
109726	44.600	Heavy Duty Spindle SLS 320/420	3144	3200	4200
109785	50.800	Heavy Duty Spindle SLS 380/480	3744	3800	4800

Used as adjustable spindle for truss beams made of Steel Walers SRU and Climbing Rails RCS.

Note
Permissible load see PERI Design Tables.

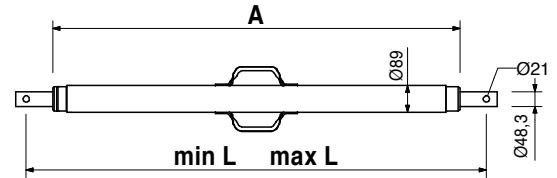
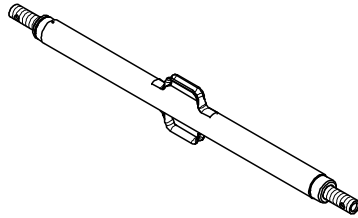

		Accessories
104031	0.462	Fitting Pin Ø 21 x 120
018060	0.030	Cotter Pin 4/1, galv.
110477	3.990	Spindle Adapter SLS/RCS

110477	3.990	Spindle Adapter SLS/RCS For connecting the Heavy-Duty Spindle SLS to the Climbing Rail RCS.
--------	-------	---

Complete with
1 pc. 104031 Fitting Pin Ø 21 x 120
1 pc. 018060 Cotter Pin 4/1, galv.

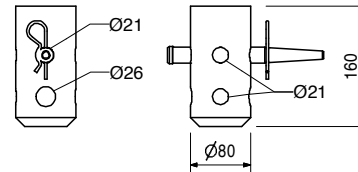
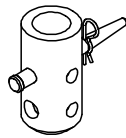

		Accessories
104031	0.462	Fitting Pin Ø 21 x 120
018060	0.030	Cotter Pin 4/1, galv.
111567	0.729	Fitting Pin Ø 26 x 120
022230	0.033	Cotter Pin 5/1, galv.

104031	0.462	Fitting Pin Ø 21 x 120 For different connections.
--------	-------	---

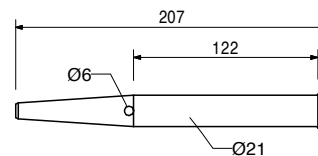
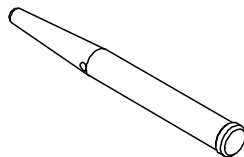

		Accessories
018060	0.030	Cotter Pin 4/1, galv.

VARIOKIT VCB Cantilever Bracket

Item no. Weight kg

018060 0.030 **Cotter Pin 4/1, galv.**

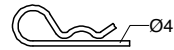

017020 1.120 **Standard Coupler NK 48/48, galv.**
For Scaffold Tubes \varnothing 48 mm.

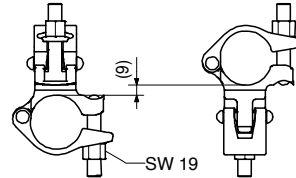
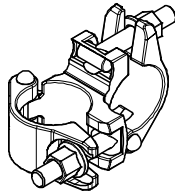

017010 1.400 **Swivel Coupling DK 48/48, galv.**
For Scaffold Tubes \varnothing 48 mm.

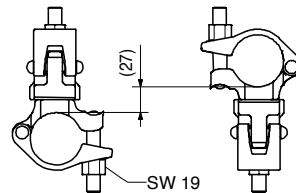
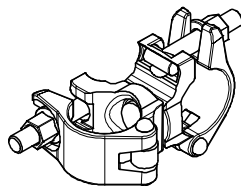

		Scaffold Tubes Steel \varnothing 48.3	L
026415	3.550	Scaff. Tube Steel \varnothing 48.3 x 3.2, special length	
026417	0.000	Cutting Cost Scaffold Tube	
026411	3.550	Scaff. Tube Steel \varnothing 48.3 x 3.2, l = 1.0 m	1000
026412	7.100	Scaff. Tube Steel \varnothing 48.3 x 3.2, l = 2.0 m	2000
026413	10.650	Scaff. Tube Steel \varnothing 48.3 x 3.2, l = 3.0 m	3000
026414	14.200	Scaff. Tube Steel \varnothing 48.3 x 3.2, l = 4.0 m	4000
026419	17.750	Scaff. Tube Steel \varnothing 48.3 x 3.2, l = 5.0 m	5000
026418	21.600	Scaff. Tube Steel \varnothing 48.3 x 3.2, l = 6.0 m	6000

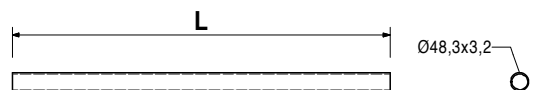
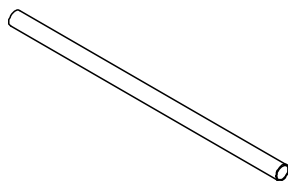

PERI International

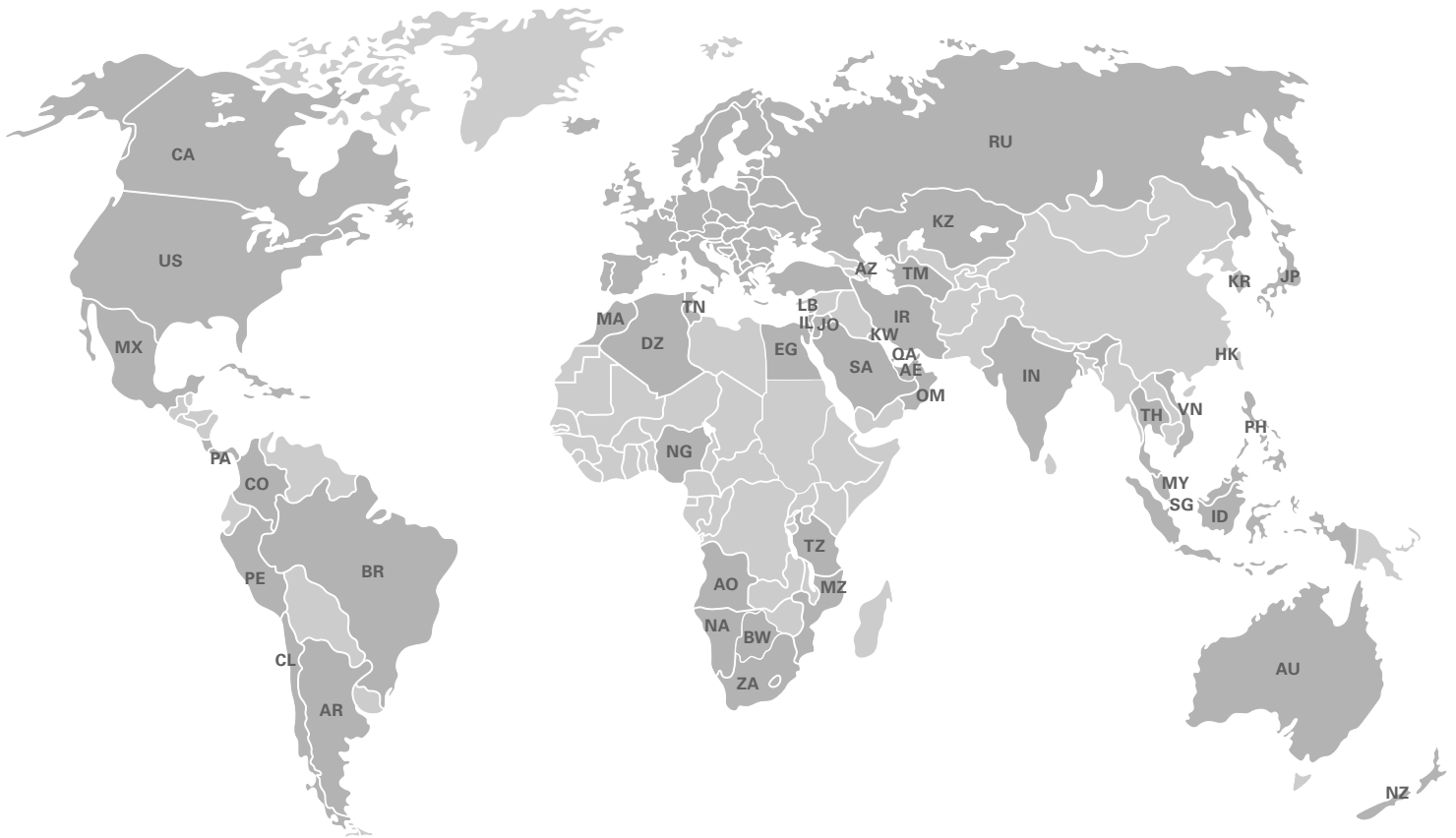

North America

- CA** Canada
PERI Formwork Systems, Inc.
www.peri.ca
- MX** Mexico
PERI Cimbras y Andamios, S.A. de C.V.
www.peri.com.mx
- PA** Panama
PERI Panama Inc.
www.peri.com.pa
- US** USA
PERI Formwork Systems, Inc.
www.peri-usa.com

South America

- AR** Argentina
PERI S.A.
www.peri.com.ar
- BR** Brazil
PERI Formas e Escoramentos Ltda.
www.peribrasil.com.br
- CL** Chile
PERI Chile Ltda.
www.peri.cl
- CO** Colombia
PERI S.A.S.
www.peri.com.co
- PE** Peru
PERI Peruana S.A.C.
www.peri.com.pe

Africa

- AO** Angola
Pericofragens, Lda.
www.peri.pt
- DZ** Algeria
S.A.R.L. PERI
www.peri.dz
- BW** Botswana
PERI (Proprietary) Limited
www.peri.co.bw
- EG** Egypt
Egypt Branch Office
www.peri.com.eg
- MA** Morocco
PERI S.A.
www.peri.ma
- MZ** Mozambique
PERI (Pty.) Ltd.
www.peri.co.mz
- NA** Namibia
PERI (Pty.) Ltd.
www.peri.na
- NG** Nigeria
PERI Nigeria Ltd.
www.peri.ng
- TN** Tunisia
PERI S.A.U.
www.peri.es
- TZ** Tanzania
PERI Formwork and Scaffolding Ltd
www.peritanzania.com
- ZA** South Africa
PERI Formwork Scaffolding (Pty) Ltd
www.peri.co.za

Asia

- AE** United Arab Emirates
PERI (L.L.C.)
www.perime.com
- AZ** Azerbaijan
PERI Representative Office
www.peri.com.tr
- HK** Hong Kong
PERI (Hong Kong) Limited
www.perihk.com
- ID** Indonesia
PT Beton Perkasa Wijaksana
www.betonperkasa.com
- IL** Israel
PERI F.E. Ltd.
www.peri.co.il
- IN** India
PERI (India) Pvt Ltd
www.peri.in
- IR** Iran
PERI Pars. Ltd.
www.peri.ir
- JO** Jordan
PERI GmbH – Jordan
www.peri.com
- JP** Japan
PERI Japan K.K.
www.perijapan.jp
- KR** Korea
PERI (Korea) Ltd.
www.perikorea.com
- KW** Kuwait
PERI Kuwait W.L.L.
www.peri.com.kw
- KZ** Kazakhstan
TOO PERI Kazakhstan
www.peri.kz
- LB** Lebanon
PERI Lebanon Sarl
lebanon@peri.de
- MY** Malaysia
PERI Formwork Malaysia Sdn. Bhd.
www.perimalaysia.com
- OM** Oman
PERI (L.L.C.)
www.perime.com
- PH** Philippines
PERI-Asia Philippines, INC.
www.peri.com.ph
- QA** Qatar
PERI Qatar LLC
www.peri.qa
- SA** Saudi Arabia
PERI Saudi Arabia Ltd.
www.peri.com.sa
- SG** Singapore
PERI Asia Pte Ltd
www.periasia.com
- TM** Turkmenistan
PERI Kalıp ve İşkeleleri
www.peri.com.tr
- TH** Thailand
Peri (Thailand) Co., Ltd.
www.peri.co.th
- VN** Vietnam
PERI ASIA PTE LTD
www.peri.com.vn

PERI

PERI GmbH
Formwork Scaffolding Engineering
 Rudolf-Diesel-Strasse 19
 89264 Weissenhorn
 Germany
 Tel. +49 (0)7309.950-0
 Fax +49 (0)7309.951-0
 info@peri.com
 www.peri.com



Oceania

AU Australia
 PERI Australia Pty. Ltd.
 www.periaus.com.au

NZ New Zealand
 PERI Australia Pty. Limited
 www.peri.co.nz

Europe

AL Albania
 PERI Kalıp ve İskeleleri
 www.peri.com.tr

AT Austria
 PERI Ges.mbH
 www.peri.at

BA Bosnia and Herzegovina
 PERI oplate i skele d.o.o
 www.peri.com.hr

BE Belgium
 N.V. PERI S.A.
 www.peri.be

BG Bulgaria
 PERI Bulgaria EOOD
 www.peri.bg

BY Belorussia
 IOOO PERI
 www.peri.by

CH Switzerland
 PERI AG
 www.peri.ch

CZ Czech Republic
 PERI spol. s r.o.
 www.peri.cz

DE Germany
 PERI GmbH
 www.peri.de

DK Denmark
 PERI Danmark A/S
 www.peri.dk

EE Estonia
 PERI AS
 www.peri.ee

ES Spain
 PERI S.A.U.
 www.peri.es

FI Finland
 PERI Suomi Ltd. Oy
 www.perisuomi.fi

FR France
 PERI S.A.S.
 www.peri.fr

GB United Kingdom
 PERI Ltd.
 www.peri.ltd.uk

GR Greece
 PERI Hellas Ltd.
 www.perihellas.gr

HR Croatia
 PERI oplate i skele d.o.o.
 www.peri.com.hr

HU Hungary
 PERI Kft.
 www.peri.hu

IR Ireland
 Siteserv Access & Formwork
 www.siteservaccess.ie

IS Iceland
 Armar ehf.
 www.armor.is

IT Italy
 PERI S.r.l.
 www.peri.it

LT Lithuania
 PERI UAB
 www.peri.lt

LU Luxembourg
 N.V. PERI S.A.
 www.peri.lu

LV Latvia
 PERI SIA
 www.peri-latvija.lv

NL Netherlands
 PERI B.V.
 www.peri.nl

NO Norway
 PERI Norge AS
 www.peri.no

PL Poland
 PERI Polska Sp. z o.o.
 www.peri.com.pl

PT Portugal
 Pericofragens Lda.
 www.peri.pt

RO Romania
 PERI România SRL
 www.peri.ro

RS Serbia
 PERI oplate d.o.o.
 www.peri.rs

RU Russia
 OOO PERI
 www.peri.ru

SE Sweden
 PERI Sverige AB
 www.peri.se

SI Slovenia
 PERI oplate i skele d.o.o
 www.peri.com.hr

SK Slovakia
 PERI spol. s r.o.
 www.peri.sk

TR Turkey
 PERI Kalıp ve İskeleleri
 www.peri.com.tr

UA Ukraine
 TOW PERI
 www.peri.ua

**The optimal System
for every Project and
every Requirement**



Wall Formwork



Column Formwork



Slab Formwork



Climbing Systems



Bridge Formwork



Tunnel Formwork



Shoring Systems



Construction Scaffold



Facade Scaffold



Industrial Scaffold



Access



Protection Scaffold



Safety Systems



System-Independent Accessories



Services



PERI Norge AS
Forskaling Stillas Engineering
 Orhusveien 6
 3070 Sande i Vestfold
 Norge
 Tel. +47 32 20 49 40
 info@peri.no
 www.peri.no