

# VGK Console Bracket System

Instructions for Assembly and Use – standard configuration – Version 2.1

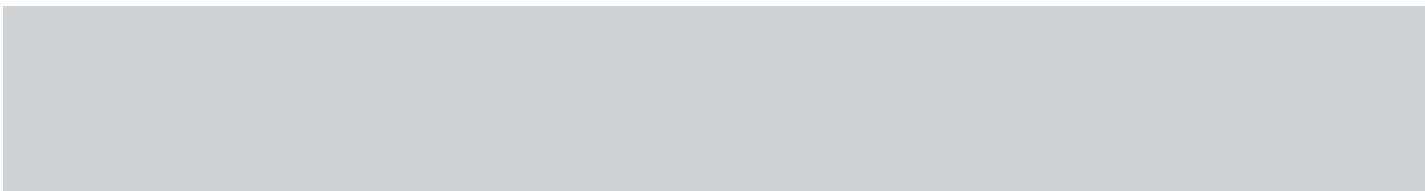

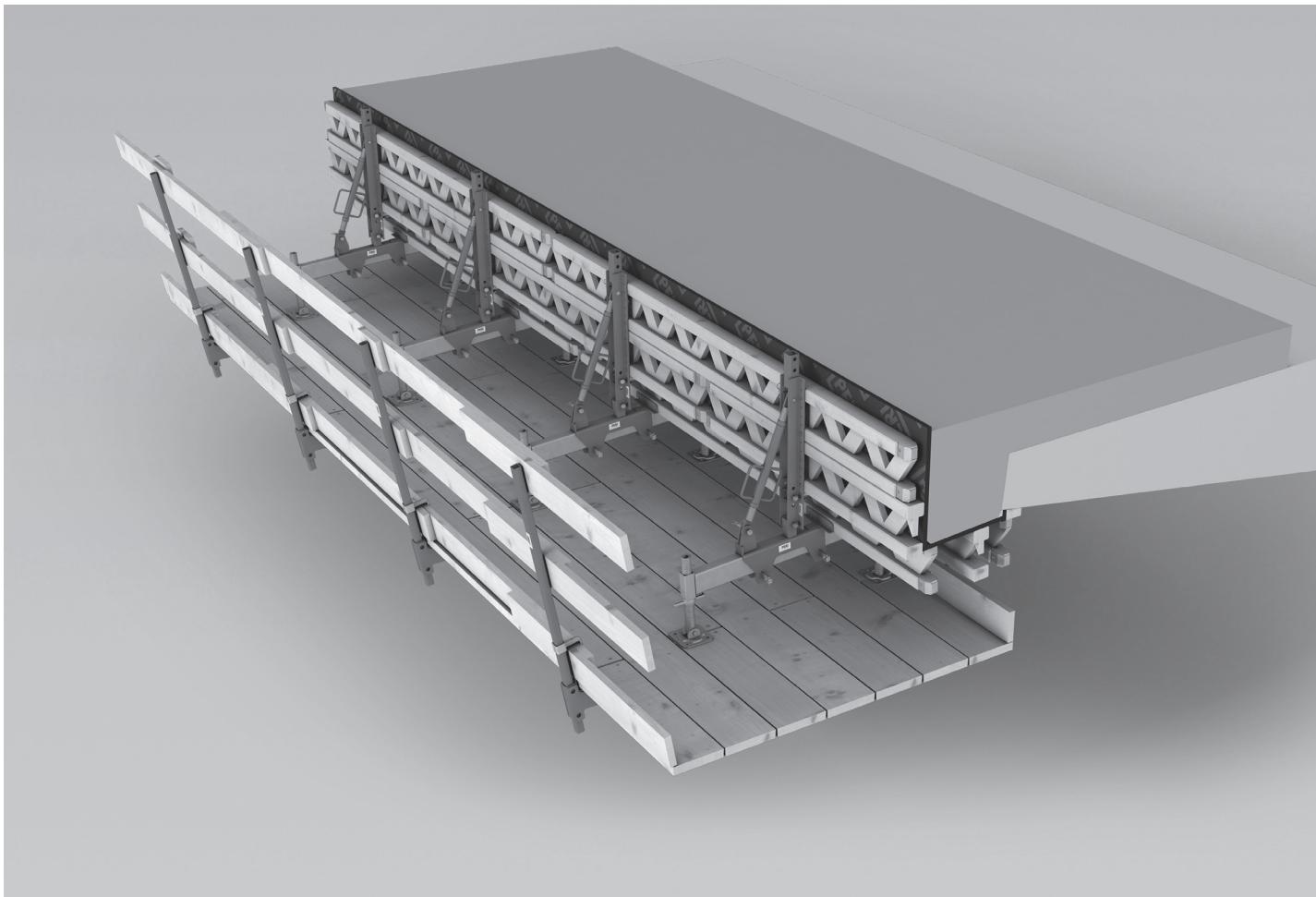

## Overview

Main components	4
Dimensions	4
Key	5

## Introduction

Target groups	6
Instructions for Use	6
Intended use	7
Additional technical documentation	7
Cleaning and maintenance instructions	8

## Safety instructions

Cross-system	9
System-specific	11
Storage and transportation	11

## Component overview and tool list

Component overview	12
Tool list and tightening torques	13

## Process planning

A1	Structural arrangements	14
	Standard use on cantilevers $\geq 75$ cm	14
	Intermediate area on cantilevers 35 – 75 cm	14
	Vertical application on abutments	15
	Work Platform VGK 160	15
	Complete 1.65 m enclosure with Guardrail Post RCS/SRU 184	16
	Complete 2.0 m enclosure with 2x Guardrail Post RCS/SRU 184	17
	Work Platform VGK Flex	18
A2	Load conditions	19
	Use as formwork scaffolding	19
	Use as Work Platform VGK 160	20
	Use as Work Platform VGK Flex on structures	21
	Use with full enclosure	22
A3	System Selection	23
	Cantilevered Parapet with Bracket Post VGK 70	23
	Cantilevered Parapet with Bracket Post VGK 110	24
	Cantilevered Parapet with Bracket Post VGK 139	25
	Work Platform VGK Flex	26
A4	Assembly guidelines	27
	Cantilevered Parapet with Bracket Post VGK 70	27
	Cantilevered Parapet with Bracket Post VGK 110	28
	Cantilevered Parapet with Bracket Post VGK 139	29
	Work Platform VGK Flex	30
A5	Anchoring	32
	On the cantilever (new structures)	32
	On abutment or wall	34
	Removal and closure	38
	Refurbishment on the cantilever	39

A6	Decks and lateral protection	42
	Platform decking	42
	Safety scaffold	42
	Lateral protection	43
A7	Storm protection	44
	Use as formwork scaffolding	44
	Use as work platform	45
A8	Horizontal bracing at $3\% < s \leq 7\%$	46
	On the cantilever	46
	On the abutment	47
A9	Horizontal bracing for crane misalignment	48
A10	Horizontal bracing for demolition work and strong vibrations	49
A11	Inspecting the Bracket Cantilever VGK 50	50

## Assembly

B1	Bracket unit	52
	Assembly on the cantilever	52
	Assembly on the abutment	55
B2	Deck unit	56
B3	Pre-assembling complete platform unit	57
	Preparing for assembly	57
	Mounting Platform VGK 160	57
	Installing Platform VGK Flex	60
B4	Attaching complete platform unit	63
	With transportation fork	63
	With round slings	64
	With suspension link A13	65
B5	Formwork unit	66
	Assembly with the Formwork Support VGK 60	66
	Assembly with the Formwork Support VGK 100	67
B6	Formwork	69

## Application

C1	Concreting	70
C2	Deshuttering	71
C3	Dismantling	72
	On the cantilever	72
	On the abutment	73
C4	Guardrail at the edge of the bridge	74
	Guardrail Post GKB	74

## Use in building construction

D1	Standing scaffold on Work Platforms VGK 160 VGK Bracket System	78
		80





## Key

### Pictogram | Definition

Danger/Warning/Caution

Note

To be complied with

Load-bearing point

Visual inspection

Tip

Incorrect use

Safety helmet

Safety shoes

Safety gloves

Safety goggles

Personal protective equipment to prevent falling from a height (PPE)

Observe additional documentation.

### Arrows

- Arrow representing an action
- Arrow representing a reaction of an action\*
- Arrow representing forces

\* If not identical to the action arrow.

### Safety instruction categories

The safety instructions alert site personnel to the risks involved and provide information on how to avoid these risks. Safety instructions can be found at the beginning of the section or before instructions for action and are highlighted as follows:

#### **Danger**

This sign indicates an extremely hazardous situation that could result in death or serious, irreversible injury if the safety instructions are not followed.

#### **Warning**

This sign indicates a hazardous situation that could result in death or serious irreversible injury if the safety instructions are not followed.

#### **Caution**

This sign indicates a hazardous situation that could result in minor or moderate injury if the safety instructions are not followed.

#### **Note**

This sign indicates situations in which failure to observe the information can result in material damage.

### Format of the safety instructions

#### **Signal word**

Type and source of hazard!  
Consequences of non-compliance.  
⇒ Preventative measures.

### Dimensions

Dimensions are usually given in cm. Other measurement units, e.g. m, are shown in the illustrations.

### Conventions

- Instructions are numbered with: 1. ...., 2. ...., 3. ....
- The result of an instruction is shown by: →
- Position numbers are clearly provided for the individual components and are given in the drawing, e.g. **1**, in the text in brackets, for example (**1**).
- Multiple position numbers, i.e. alternative components, are represented with a slash: e.g. **1/2**.

### Notes on illustrations

The illustration on the front cover of these instructions is understood to be a system representation only. The assembly steps presented in these Instructions for Assembly and Use are shown in the form of examples with only one component size. They are valid for all component sizes contained in the standard configuration.

To facilitate understanding, detailed illustrations are sometimes incomplete. The safety equipment that might not be shown in these detailed illustrations must nevertheless be available.

## Target groups

### Contractors

These Instructions for Assembly and Use are designed for contractors who either

- assemble, modify and dismantle PERI systems, or
- use them, e.g. for concreting, or
- allow them to be used for other operations, e.g. carpentry or electrical work.

### Safety and Health Protection Coordinator\*

- is appointed by the client,
- must identify potential hazards during the planning phase,
- determines measures that provide protection against risks,
- creates a safety and health protection plan,
- coordinates the protective measures for the contractor and site personnel so that they do not endanger each other,
- monitors compliance with the protective measures.

### Competent person

- is appointed by the contractor,
- must be on site for all system operations,
- prepares and updates the plan for assembly, modification and dismantling,
- prepares and updates the plan for use of the system by the user,
- supervises the assembly, modification and dismantling work (supervisor).

### Competent persons qualified to carry out inspections

Due to the specialist knowledge gained from professional training, professional experience and recent professional activity, the competent person qualified to carry out inspections has a reliable understanding of safety-related issues and can carry out inspections correctly. Depending on the complexity of the inspection to be undertaken, e.g. scope of testing, type of testing or the use of certain measuring devices, a range of specialist knowledge is necessary.

### Qualified personnel

PERI systems may only be assembled, modified or dismantled by personnel who are suitably qualified to do so. Qualified personnel must have completed a course of training\*\* in the work to be performed, covering the following points at least:

- Explanation of the plan for the assembly, modification or dismantling of the system in an understandable form and language.
- Description of the measures for safely assembling, modifying or dismantling the system.
- Naming of the preventive measures to be taken to avoid the risk of persons and objects falling.

- Designation of the safety precautions in the event of changing weather conditions that could adversely affect the safety of the system, as well as the personnel concerned.
- Details regarding permissible loads.
- Description of all other risks and dangers associated with assembly, modification or dismantling operations.



- **Ensure that relevant national guidelines and regulations in the respective current version are complied with!**
- **If no country-specific regulations are available, PERI recommends that you proceed according to German guidelines and regulations.**

\* Valid in Germany e.g.: Regulations for Occupational Health and Safety on Construction Sites 30 (RAB 30).

\*\* Instructions are given by the contractor themselves or a competent person selected by them.

## Instructions for Use

Use in a way not intended, deviating from the standard configuration or the intended use according to the Instructions for Assembly and Use, represents a misapplication with a potential safety risk, e.g. risk of falling.

Only PERI original components may be used. The use of other products and spare parts is not allowed and represents a misapplication with associated safety risks.

Changes to PERI components are not permitted.

The system described in these Instructions for Assembly and Use may contain patent-protected components.

## Intended use

### Product description

PERI products have been designed for exclusive use in the industrial and commercial sectors only by suitably trained personnel.

The VGK Console Bracket System is used for the concreting of cantilevered parapets in cantilever and abutment areas of bridges cast in-situ or constructed using prefabricated elements.

The VGK Console Bracket System system can also be used as a pure work platform, either in the standard configuration VGK 160 or in the VGK Flex configuration.

The system facilitates the forming of parapet geometries up to H/W = 100/60 cm. Work platforms and formwork units are separate. This allows the formwork unit to be readjusted to match the geometry of the parapet from the work platform.

The individual bracket consists of a standard, bracket cantilever, platform beam and spindle, and can be fixed to the bridge at variable distances to one another depending on the parapet cross-section, thus resulting in excellent load optimisation.

In the VGK Flex configuration as a work platform, a single bracket is composed of a standard, formwork girder and Kicker AV.

When used in bridge construction, the console bracket is anchored using the Anchor Sleeve M24. For refurbishment work, the console bracket can be anchored afterwards by means of composite anchoring systems.

In combination with Suspension Head Flex VGK, two bracket discs can also be suspended from the structure as pre-assembled units. With both Suspension Head VGK and Suspension Head Flex VGK, all structural arrangements can be carried out. (Exception: VGK 70 with formwork construction at the abutment)

### Features

- Platform and formwork units are separated.
- No openings or penetration in the platform decking.
- Operation and adjustment is carried out from the work platform.
- Continuous inclination adjustment of the slab and side formwork.
- High load-bearing capacity.

### Technical data

- Parapet dimensions:  
max. H/W = 100/60 cm.
- Perm. influence widths up to 185 cm.

---

## Additional technical documentation

- Approvals:
  - Approval No. Z-21.6-1764 Alternative Anchoring
  - Approval No. Z-21.6-1766 PERI Screw-On Cone for the Anchoring of Bracket Scaffold
  - Approval No. Z-21.6-1768 Peri Anchor Sleeve M24 and PERI Anchor Sleeve DW 15
  - Approval No. Z-21.8-2048 Refurbishment Anchor
- Design information:
  - Design Information for the VARIOKIT VGK
- Instructions for Assembly and Use:
  - Concrete cones and concrete adhesive tie points
  - MAXIMO System Supplement
- User information:
  - Pallets and stacking devices
- Type tests:
  - VARIOKIT VGK Cantilevered Parapet Bracket
- Technical Data Sheets
  - Screw-On Sleeve M16/164
- Design Tables 2015 – Formwork and Shoring
- Product brochures:
  - DK, SK anchor technology – Reliable sealing of clamping points

## Cleaning and maintenance instructions

In order to maintain the value and operational readiness of the formwork materials over the long term, clean the panels after each use.

Some repair work may also be inevitable due to the tough working conditions.



The contractor must ensure that the personal protective equipment required for cleaning, maintenance and repair work such as

- Safety helmet,
- Safety shoes,
- Safety gloves,
- Safety goggles,

is available and used as intended.

The following instructions should help to keep cleaning and maintenance costs as low as possible.

Cleaning tools must be adapted to the respective surfaces of the components so that they are not damaged.

Spray the formwork on both sides with concrete release agent before each use; this makes the formwork easier and faster to clean. Spray the concrete release agent very thinly and evenly!

Do not spray work platforms and access routes with concrete release agent.

Slip hazard.

Spray the rear side of the formwork with water immediately after concreting; this avoids any time-consuming and costly cleaning operations.

When used continuously, spray the formlining elements with concrete release agent immediately after deshuttering; then clean by means of a scraper, brush or rubber lip scraper. Important: do not clean formlining made of plywood with high-pressure equipment. This could result in the formlining being damaged.

Fix recesses and built-in parts with double-headed nails; as a result, the nails can easily be removed later, and damage to the formlining is largely avoided.

Close all unused tie holes with plugs; this eliminates any subsequent cleaning or repair work.

Tie holes accidentally blocked with concrete are cleared by means of a steel pin from the formlining side.

When placing bundles of reinforcement bars or other heavy objects on horizontally supported formwork elements, suitable support, e.g. squared timbers, is to be used: this prevents impressions and damage to the formlining to a large extent.

Internal concrete vibrators should be fitted with rubber caps if possible; as a result, any damage to the formlining is reduced if the internal vibrator is accidentally inserted between the reinforcement and formlining.

Never clean powder-coated components, e.g. elements and accessories, with steel brushes or hard metal scrapers; this preserves the powder coating. Use spacers for reinforcements with large or flat supports; this largely avoids indentations in the formlining under load.

Mechanical components, e.g. spindles or gear mechanisms, must be cleaned of dirt or concrete residue before and after use, and then greased with a suitable lubricant.

Provide suitable support for the components during cleaning so that no unintentional change in their position is possible.

Do not clean components suspended on crane lifting gear.

## Cross-system



### Safety instructions apply to all service life phases of the system.

#### General information

The contractor must ensure that the Instructions for Assembly and Use supplied by PERI are available at all times and understood by the site personnel.

These Instructions for Assembly and Use can be used as the basis for creating a risk assessment. The risk assessment is compiled by the contractor. The Instructions for Assembly and Use are not a substitute for a risk assessment!

Observe and comply with the safety instructions and permissible loads.

For the application and inspection of PERI products, observe the current laws and regulations in force in the respective countries.

Materials and working areas are to be inspected before each use and assembly, for:

- damage,
- stability and
- functional correctness.

Damaged components must be exchanged immediately on site and may no longer be used.

Safety components are to be removed only when they are no longer required.

When on slab formwork, scaffolds and working platforms:

- do not jump,
- do not run,
- do not drop anything from or onto it.

Components provided by the contractor must comply with the characteristics stipulated in these Instructions for Assembly and Use and all applicable laws and standards. Unless otherwise indicated, the following applies in particular:

- Timber components:  
Strength class C24 for solid wood according to DIN EN 338:2016-07.
- Scaffolding tubes:  
Galvanised steel tubes with minimum dimension  $\varnothing$  48.3 x 3.2 mm according to DIN EN 12811-1:2004-03 4.2.1.2.
- Scaffolding tube couplings:  
according to DIN EN 74-1:2022-09 and DIN EN 74-2:2022-09.

Deviations from the standard configuration are only permitted after a further risk assessment has been carried out by the contractor.

Appropriate measures for working and operational safety, as well as stability, are defined on the basis of this risk assessment.

Corresponding proof of stability can be provided by PERI on request if the risk assessment and resulting measures to be implemented are made available.

Nails and wood screws must not protrude. Only allow other connecting components to protrude to the extent that is necessary.

If necessary, mark protruding components or fit them with protective material.

Secure all bolts with cotter pins and all screws with nuts

Before and after extraordinary events that may have damaging effects on the safety of the climbing system, the contractor shall immediately

- produce another risk assessment and make use of its results to take suitable steps to guarantee the stability of the climbing system,
- arrange for an extraordinary inspection to be carried out by a competent person qualified to do so. The aim of this inspection is to detect and repair damage in good time in order to ensure the safe use of the system.

Exceptional events could be:

- accidents,
- long periods of non-use,
- natural events, e.g. heavy rainfall, icing, heavy snowfall, storms or earthquakes.

## Assembly, modification and dismantling work

PERI systems may only be assembled, modified or dismantled under the supervision of a person qualified to do so and by technically suitable employees. The qualified personnel must have received appropriate training for the work to be carried out with regard to specific risks and dangers.

On the basis of the risk assessment and the Instructions for Assembly and Use, the contractor must create assembly instructions to guarantee safe assembly, modification and dismantling of the system.



The contractor must ensure that the personal protective equipment required for the assembly, modification or dismantling of the system, e.g.

- Safety helmet,
- Safety shoes,
- Safety gloves,
- Safety goggles,

is available and used as intended.

For work at a higher level, use an approved ladder or platform system, or an assembly scaffold.



If personal protective equipment against falling from a height (PPE) is required or specified in local regulations, the contractor must determine appropriate attachment points on the basis of the risk assessment.

The PPE to be used to prevent falling is determined by the contractor.

The contractor must

- provide safe working areas for site personnel, which are to be reached through the provision of safe access ways. cordon off and clearly mark danger zones.
- guarantee stability during all stages of construction, in particular during assembly, modification and dismantling operations.
- ensure and demonstrate that all loads that occur are safely transferred.

## Use

Every contractor who uses or allows the systems to be used, is responsible for ensuring that the equipment is in good condition.

If the system is used successively or at the same time by several contractors, the health and safety coordinator must point out any possible mutual hazards and all work must then be coordinated.

When systems are used in publicly accessible areas,

- measures to prevent unauthorised use, e.g. enclosure of access areas, must be taken.
- Measures are taken against injuries caused by bumping against protruding components, e.g. assembly of protective components.

Always keep the contact surfaces of the system free of dirt, objects, snow and ice.

Close off the system in extreme weather conditions.

## System-specific

Deshutter components only when the concrete has sufficiently hardened and the person in charge has given the go-ahead for deshuttering to take place.

Working areas situated below must be protected by means of appropriate measures.

Secure tools and materials to prevent them from falling to the ground. Remove concrete residue and other forms of dirt.

Every cantilevered parapet bracket must have its own anchoring. Loosening or removing the anchoring must only be possible from the load transfer side.

Constructional requirements regarding the use of the anchoring methods are to be taken into account.

Check that the anchor is correctly installed before concreting takes place. PERI recommends compiling an acceptance report.

Anchoring is to take place only if the anchorage has sufficient concrete strength.

Screw Anchor Sleeve M24 as far as possible on the fibre cement pipe on Anchor Posit. Stud M24 ga.

The threaded areas on Screw-On Cone-2 as well as Threaded Plates DW 20 must always be completely screwed in.

The required anchoring depth  $h$  must not be achieved through a reduction in the screw-in depth.

Avoid standing under suspended loads. If work under suspended loads cannot be avoided, come up with suitable safety measures and apply them. Avoid standing between a fixed object and an object that is drawing near.

Do not use any anchoring components and mountings in advance that are damaged.

Examples of damage:

- deformed components,
- rough or scratched cone surfaces,
- blocked threads,
- weld splashes on the threads.

Check the functionality of the slide bearings before every use. Do not use Bracket Cantilever VGK 50 if the grouting is damaged.

The contractor must ensure that there is safe lightning and current discharge facilities.

## Storage and transportation

Store and transport components in such a way that no unintentional change in their position is possible. Detach load-lifting accessories and lifting gear from the lowered components only if they are in a stable position and no unintentional change is possible.

Do not drop the components.

Use PERI lifting accessories and lifting gear and only those load-bearing points provided on the component.

During the relocation procedure

- ensure that components are picked up and set down in such a way that unintentional falling over, falling apart, sliding, falling down or rolling is avoided.
- no one is allowed to remain under the suspended load.

Pre-assembled assemblies should always be guided with ropes when moving them by crane.

The access areas on the construction site must be free of obstacles and tripping hazards, as well as being slip-resistant.

For transportation, the substrate must be clean, level and have sufficient load-bearing capacity.

Use original PERI storage and transport systems, e.g. crate pallets, pallets or stacking devices.



# Component overview

Pos. no.	Component name	Article no.	Pos. no.	Component name	Article no.
<b>1a</b>	Bracket Post VGK 70	134161	<b>40</b>	Height compensation	–
<b>1b</b>	Bracket Post VGK 110	124404	<b>41</b>	Wire Nail 3.0x80 mm	710312
<b>1c</b>	Bracket Post VGK 139	124427	<b>42</b>	Screw-On Sleeve M16/164	123970
<b>2a</b>	Kicker Brace AV 82	123846	<b>43</b>	Screw ISO 4017-M16x120-8.8-ga	–
<b>2b</b>	Kicker Brace AV 111	123847	<b>44</b>	Washer ISO 7094-16-100HV-ga.	113349
<b>2c</b>	Kicker Brace AV 140	028110	<b>45</b>	Anchor Posit. Plate M24 ga	029280
<b>3</b>	Bracket Cantilever VGK 50	124455	<b>46</b>	Advancing Screw M24 ga	029270
<b>4</b>	Platform Cantil. Beam VGK 170	124447	<b>47</b>	Hex wood screw 6x20 DIN571	029440
<b>5</b>	Formwork Fixing-2 VGK	124394	<b>48</b>	Blow-out pump	130015
<b>6</b>	Formwork Support VGK 100	124438	<b>49</b>	Cleaning Brush D24	130011
<b>7</b>	Formwork Post VGK 70	124371	<b>50</b>	Composite Mortar CF-T 300 V	129628
<b>8</b>	Formwork Post VGK 120	138061	<b>51</b>	Connection Bolt M16/M24x50	130012
<b>9</b>	Adj. Base Plate UJB 38 mm-80/55	100242	<b>52</b>	ITH-Sleeve TSM BC 22x75 mm IM16	129637
<b>10</b>	Bracing Connector VGK	124934	<b>54</b>	Internal formwork	–
<b>11</b>	Cutting Costs Scaffold Tube Ø48.3x3.2 mm	026417	<b>55</b>	Wood-Screw 6x60 SK-TX30 HPI	024470
<b>12a</b>	Suspension Head VGK Flex	138071	<b>56</b>	Tie Rod DW15, special length	030340
<b>12b</b>	Suspension Head VGK	124413	<b>57</b>	Hex-Nut DW15 SW30 50 mm ga	030070
<b>13</b>	Anchor Sleeve M24	026230	<b>58</b>	Formwork panel	–
<b>14</b>	Cone FRC Ø32/52 mm C=40 mm	116233	<b>59</b>	Eye Nut RCS DW15	115378
<b>15</b>	Anchor Position. M24x65 mm ga	115150	<b>60</b>	Pin Ø16x90 mm coat	118463
<b>16</b>	Screw ISO 4014-M24x100-8.8-ga	124031	<b>61</b>	Cotter Pin 4/1 ga	018060
<b>17</b>	Threaded Cone M24/40 mm	123800	<b>62</b>	Guardrail Holder VGK	138056
<b>18</b>	Wire Nail 4.6x130 mm	129157	<b>63</b>	Multi-layer plywood sheet	–
<b>19a</b>	Concrete Plug Ø40 mm	123820	<b>64</b>	Angle bracket 90x90x65 mm	123479
<b>19b</b>	Concrete Plug Ø32 mm	116234	<b>65</b>	Swivel Coupler SW Ø48/48 mm ga	017010
<b>20</b>	Threaded Anchor Plate DW20	030860	<b>66</b>	Wall Formwork Bracket MX WK	135327
<b>21</b>	Screw-On Cone-2 M24/DW20	114158	<b>67</b>	Guardrail Post SGP	061260
<b>22</b>	Anchor Posit. Stud M24 ga	026420	<b>68</b>	Bracing Shoe VGK	138455
<b>23</b>	Screw ISO 4014-M24x070-10.9	026430	<b>69</b>	Girder Support coat	124364
<b>24</b>	Hex-Nut ISO 7040-M24-8-ga	105032	<b>70</b>	Fork	–
<b>25</b>	Guardrail Post GKB	114299	<b>71</b>	Round sling	–
<b>27</b>	Anchor Lock VGK B15	134174	<b>72</b>	Four-strand hanger	–
<b>28</b>	Anchor VGK B15	134173	<b>73</b>	Anchor Bolt Ø14/20x130 mm	124777
<b>29</b>	Guardrail Post-2 HSGP	116292	<b>74</b>	Cone PP Ø31/26 mm C=25 mm	026240
<b>30</b>	Guardrail Post RCS/SRU 184	114328	<b>75</b>	Suspension Link A13	710671
<b>31</b>	Repoxal glue	031550	<b>76</b>	Screw-on Coup.- 2 HT BØ48 mm M20	131404
<b>32</b>	Swivel Coup. EN74 SW38/48 mm ga	102400	<b>77</b>	Formwork Support VGK 60	134169
<b>33</b>	Guardrail boards	–			
<b>34</b>	Toe boards	–			
<b>35</b>	Planking	–			
<b>36</b>	Wire pin/wood screws	–			
<b>37</b>	Squared timber	–			
<b>38</b>	Plank 20 x 4	–			
<b>39</b>	Wood screw 6x80 SK-TX30 HPI	024690			



Tool name
Ratchet wrench
Extension for the ratchet wrench
Socket wrench AF 13
Socket wrench AF 36
Ring/open-end wrench AF 13/AF 36
Cordless screwdriver
Wood drill Ø 8.5 mm
Screw bits Torx 30
Socket wrench AF 36, chrome-plated, article no. 031480
Hexag. Recess Wrench SW14 long, article no. 027212
Hammer

## Tightening torques

Unless otherwise indicated, PERI recommends the following guide values for screw connections as "hand-tightened" tightening torques  $M_{A,hand-tightened}$ .

These guide values are based on DIN EN 15048-1:2016-09 with minimum Safety Factor 3 against breakage.

Quality class	Quality 4.6		Quality 8.8 and 10.9
	Lightly oiled	MoS2	Undefined
Screw M8	8 Nm	6.6 Nm	8 Nm
Screw M10	16 Nm	13.0 Nm	16 Nm
Screw M12	30 Nm	23.0 Nm	30 Nm
Screw M16	65 Nm	54.0 Nm	65 Nm
Screw M20	100 Nm		100 Nm
Screw M24	150 Nm		150 Nm
Screw M30	260 Nm		260 Nm
Screw M36	350 Nm		350 Nm

Tightening torques have been determined for the following components:

Scaffolding tube coupling	50 Nm
Clamping plate for the slab tie gauge	120 Nm

## Standard use on cantilevers $\geq 75$ cm

(Fig. A1.01)

Take into account Section A3 – System Selection.

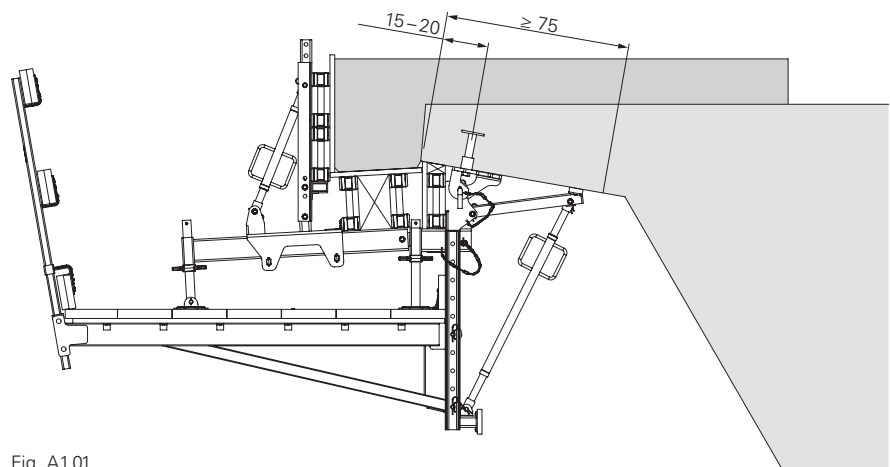

Fig. A1.01

## Intermediate area on cantilevers 35 – 75 cm



- Secure Adj. Base Plate UJB 38 mm-80/55 (9) against falling out and unintentional twisting, e.g. Screw-on Coup.-2 HT BØ48 mm M20 (76) (article no.: 131404).
- The application with Adj. Base Plate UJB 38 mm-80/55 (9) must be calculated separately for each project.
- In the case of pressure points on sloping walls, the spindle must be verified and secured against slipping in a project-specific manner.
- If Suspension Head VGK Flex (12a) is used, the influence width may be limited.

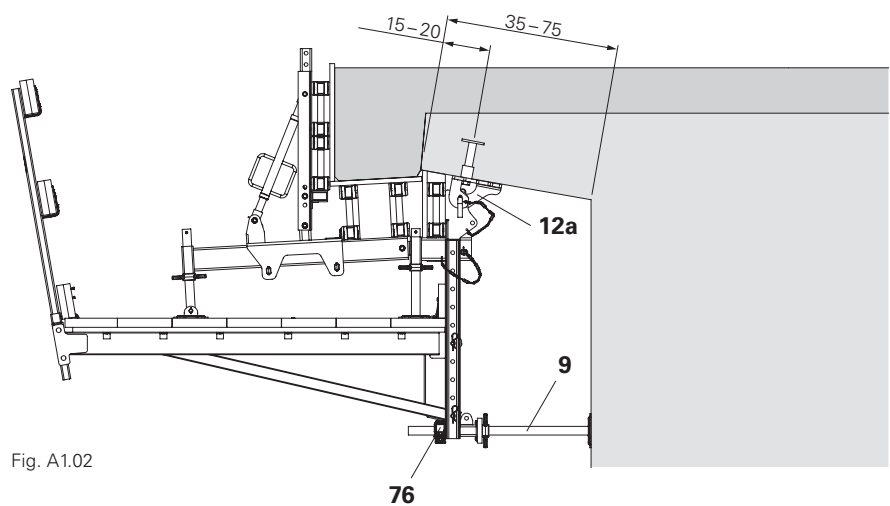

Fig. A1.02

With Adj. Base Plate UJB 38 mm-80/55 (9).  
(Fig. A1.02)

Take into account Section A3 – System Selection.

## Vertical application on abutments

Dimension x according to project-specific planning.  
(Fig. A1.03)

Take into account Section A3 – System Selection.

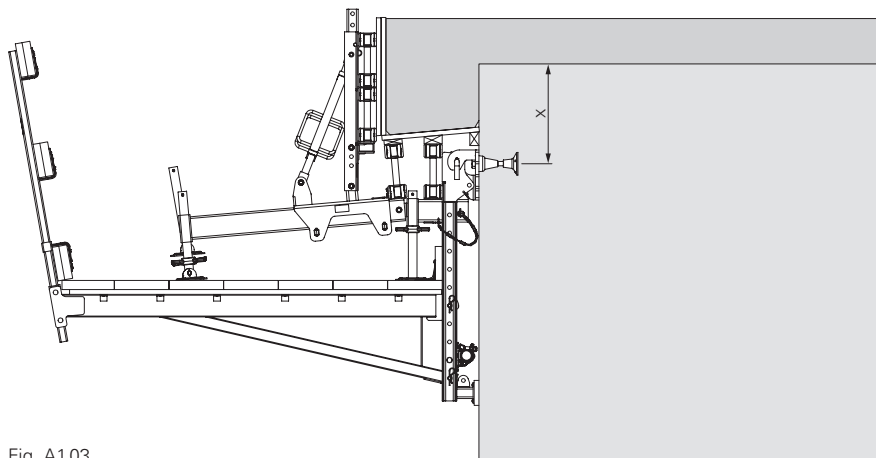

Fig. A1.03

## Work Platform VGK 160 Cantilever

(Fig. A1.04)

## Abutment

(Fig. A1.05)

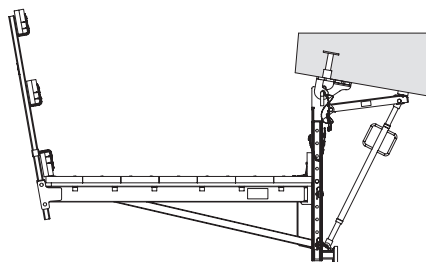

Fig. A1.04

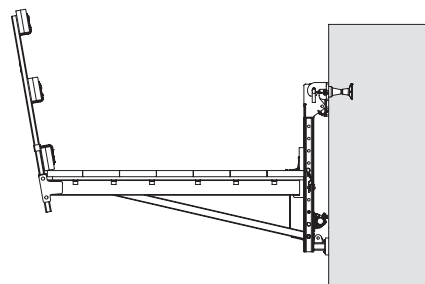

Fig. A1.05

## Complete 1.65 m enclosure with Guardrail Post RCS/SRU 184



- Installation of the complete enclosure is project-specific.
- Refer to the assembly plans.

### Assembly

1. Attach Guardrail Post RCS/SRU 184 (30) to Platform Cantil. Beam VGK 170 (4), AF 30.
2. Screw the enclosure to the guardrail posts. (Fig. A1.06 – Fig. A1.06b)

Take into account Section A3 – System Selection.

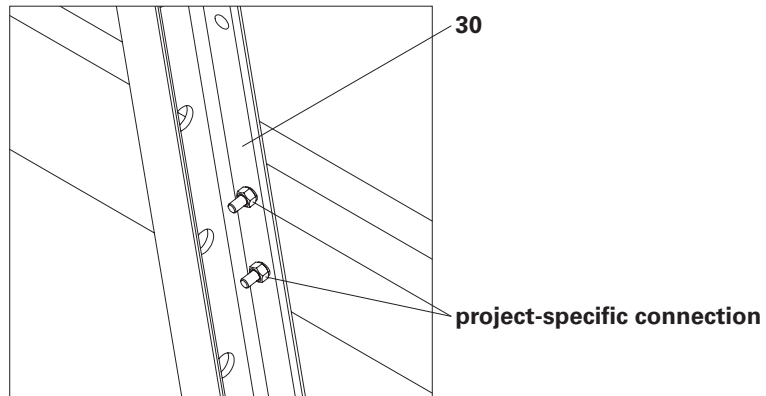

Fig. A1.06b

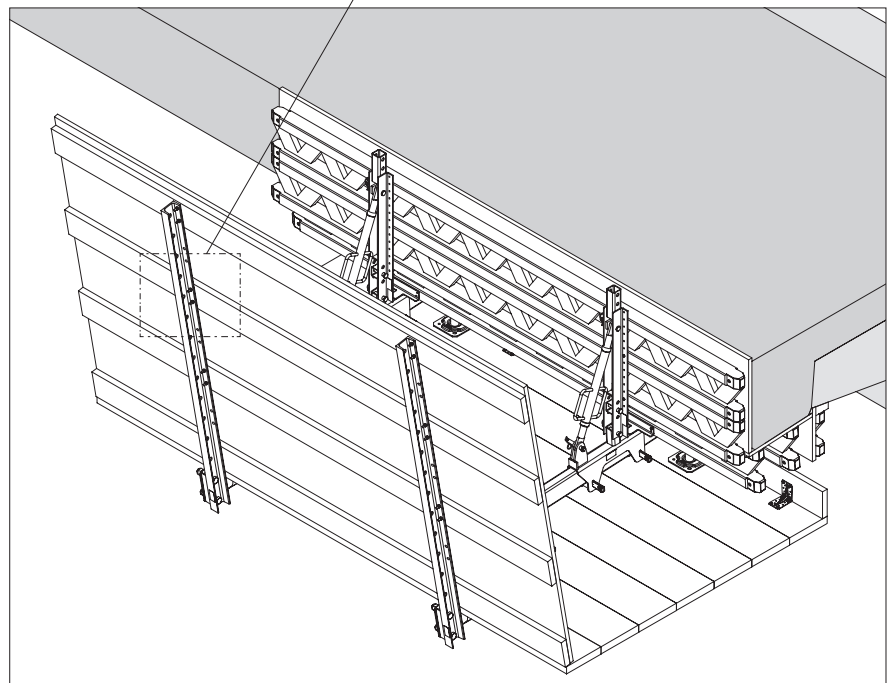

Fig. A1.06

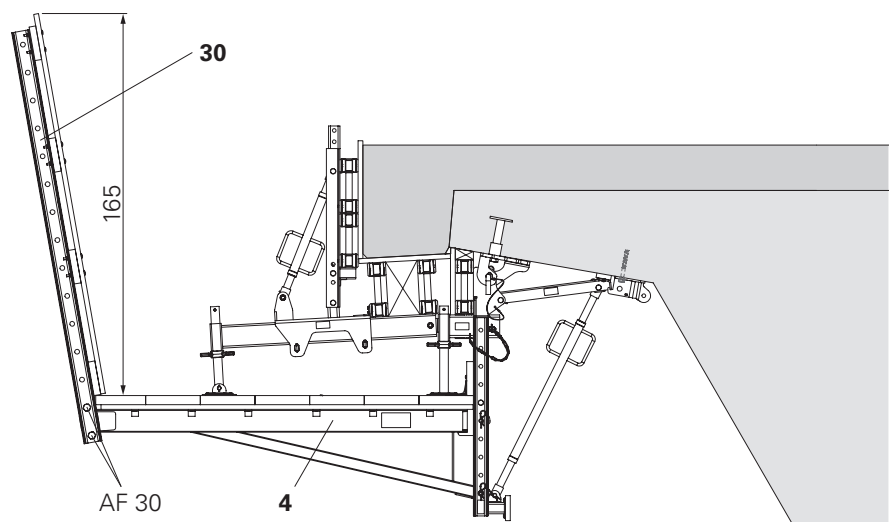

Fig. A1.06a

## Complete 2.0 m enclosure with 2x Guardrail Post RCS/SRU 184



- In the case of complete enclosure using two Guardrail Posts RCS/SRU, both must be bolted down wherever possible.
- The additional screws on the Guardrail Post RCS/SRU (**30b**) are not required and can either be tightened or removed.
- Installation of the complete enclosure is project-specific.
- Refer to the assembly plans.

### Assembly

1. Place Guardrail Post RCS/SRU 184 (**30a**) up against Platform Cantilever Beam VGK 170 (**4**).
  2. Fit the screws, AF30.
  3. Fit the second Guardrail Post RCS/SRU (**30b**) onto the bolts and tighten with nuts.
  4. Screw the enclosure to the guardrail posts.
- (Fig. A1.07 – Fig. A1.07b)

Take into account Section A3 – System Selection.



Have all connections been made?

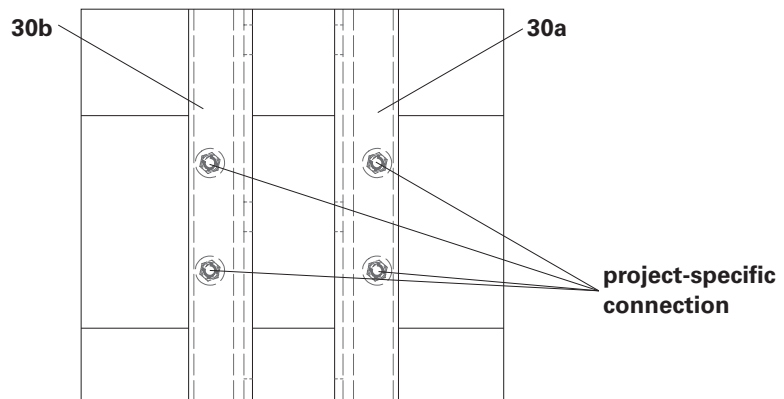

Fig. A1.07b

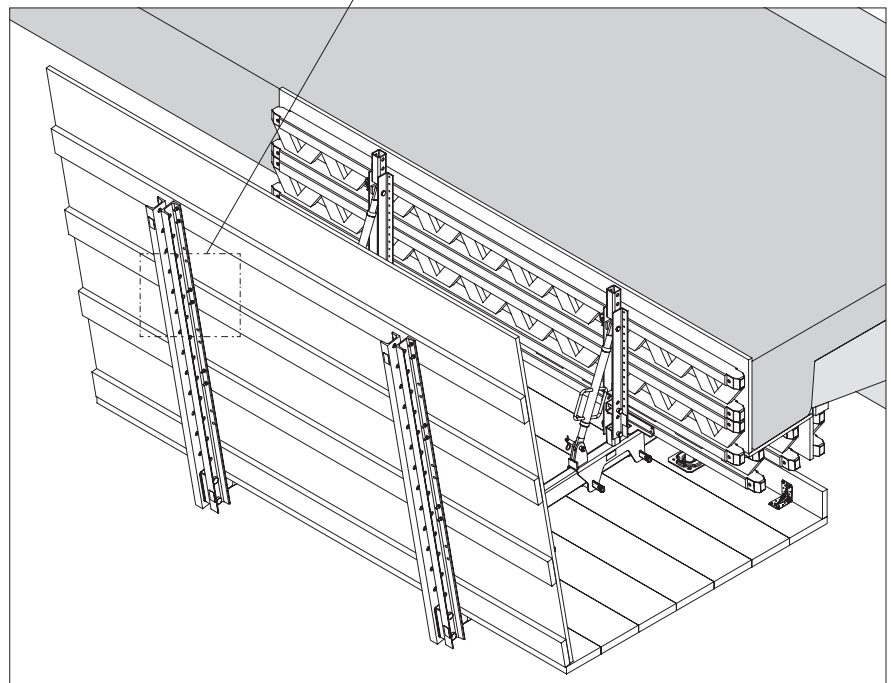

Fig. A1.07

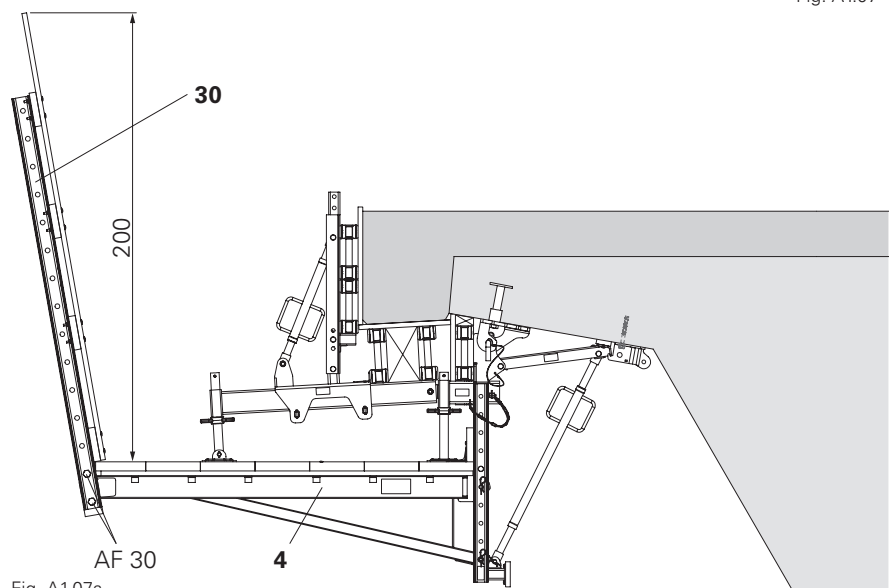

Fig. A1.07a

## Work Platform VGK Flex



The Kicker Brace AV is always bolted into the front hole together with the Guardrail Holder VGK.

### VGK Flex 70

Formwork Post VGK 70 (7) as the platform beam  
(Fig. A1.08)

Take into account Section A3 – System Selection.

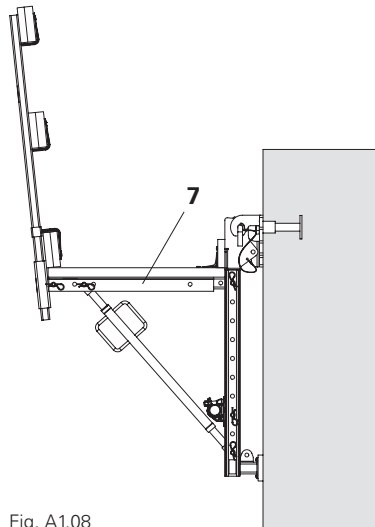

Fig. A1.08

### VGK Flex 90

Formwork Post VGK 120 (8) as the platform beam  
(Fig. A1.09)

Take into account Section A3 – System Selection.

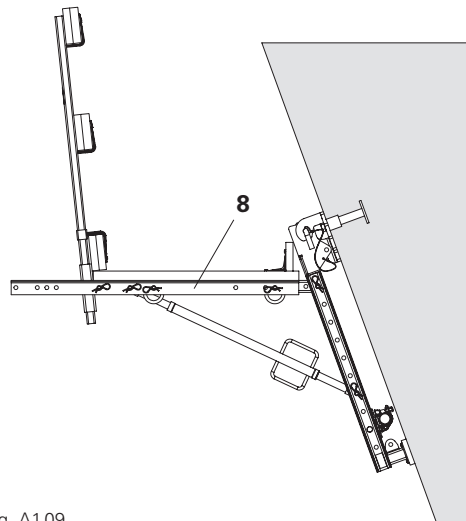

Fig. A1.09

### VGK Flex 120

Formwork Post VGK 120 (8) as the platform beam  
(Fig. A1.10)

Take into account Section A3 – System Selection.

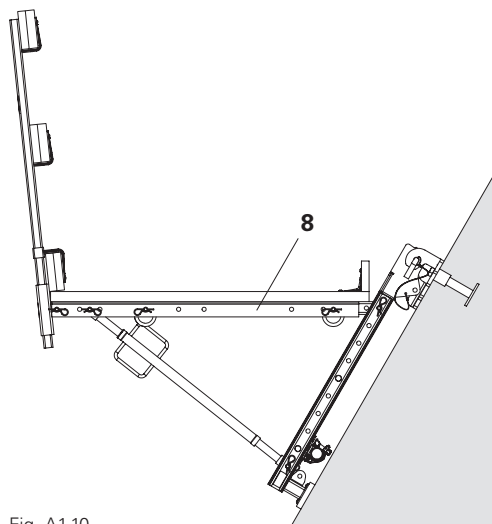

Fig. A1.10

## Use as formwork scaffolding



- All given loads are characteristic loads.

### Working/concreting

- Set up formwork.
- Install reinforcement in the cantilevered parapet.
- Close side formwork and concrete.
- Deshuttering.
- Inspection and maintenance.

Load case for working	
Live load on the platform	2.00 kN/m <sup>2</sup>
Max. working wind speed	0.20 kN/m <sup>2</sup> (V <sub>w</sub> = 64 km/h)

Tab. A2.01

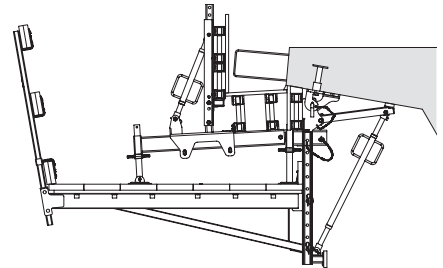

Fig. A2.01

Load Case: Concreting	
Live load on the platform	0.75 kN/m <sup>2</sup>
Max. working wind speed	0.20 kN/m <sup>2</sup> (V <sub>w</sub> = 64 km/h)
Hydrostatic fresh concrete pressure with $\gamma_{\text{concrete}} = 25 \text{ kN/m}^3$	

Tab. A2.02

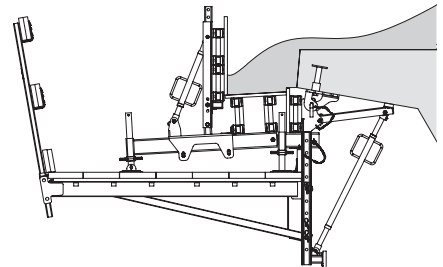

Fig. A2.02

### Storm (non-operational)

During longer work breaks or storm warnings with wind speeds > 64 km/h.



- All given loads are characteristic loads.
- Implement safety measures according to Section A7.
- Remove loose materials and equipment.
- Do not access console brackets in storm conditions.
- For storm warnings with wind speeds > 111 km/h, inform an authorised person and implement separate safety measures.

Load case: Storm	
Live load on the platform	0.00 kN/m <sup>2</sup>
Peak velocity pressure q <sub>p</sub> (z)*	≤ 0.60 kN/m <sup>2</sup> (V <sub>w</sub> ≤ 111 km/h)

\*Max. peak velocity pressure q<sub>p</sub>(z) including reduction for temporary construction.

Tab. A2.03

## Use as Work Platform VGK 160



- All given loads are characteristic loads.
- All demolished concrete is immediately removed. No accumulation of demolished concrete.
- Secure working areas located underneath against falling objects.

### Work

- Demolish existing cantilevered parapet.
- Continuously remove demolished concrete from the work platform.
- Carry out refurbishment work.
- Demolition work:
  - Demolish existing cantilevered parapet.
  - Demolished concrete.
  - Refurbishment work.
- Access for formwork work on buildings.
- Platform for reinforcement scaffolds.

Load case for working	
Live load on the platform	2.00 kN/m <sup>2</sup>
Max. working wind speed	0.20 kN/m <sup>2</sup> (V <sub>w</sub> = 64 km/h)

Tab. A2.04

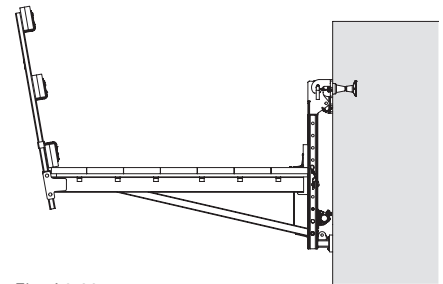

Fig. A2.03

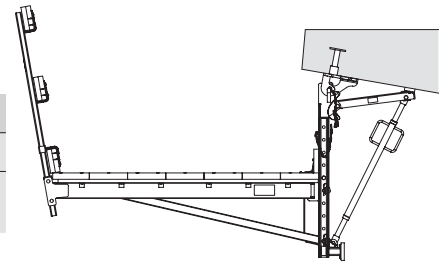

Fig. A2.04

### Storm (non-operational)

During longer work breaks or storm warnings with wind speeds > 64 km/h.



- All given loads are characteristic loads.
- Safeguarding measures, see Section "A7 Storm protection" on page 44.
- Remove loose materials and equipment.
- Do not access console brackets in storm conditions.
- For storm warnings with wind speeds > 111 km/h, inform an authorised person and implement separate safety measures.

Load case: Storm	
Live load on the platform	0.00 kN/m <sup>2</sup>
Peak velocity pressure q <sub>p</sub> (z)*	≤ 0.60 kN/m <sup>2</sup> (V <sub>w</sub> ≤ 111 km/h)

\*Max. peak velocity pressure q<sub>p</sub>(z) including reduction for temporary construction.

Tab. A2.05



## Use as Work Platform VGK Flex on structures



- All given loads are characteristic loads.
- Secure working areas located underneath against falling objects.
- Can also be mounted on sloping walls.

### Work

- Material/equipment with low loads can be parked on the work platform for a short time.

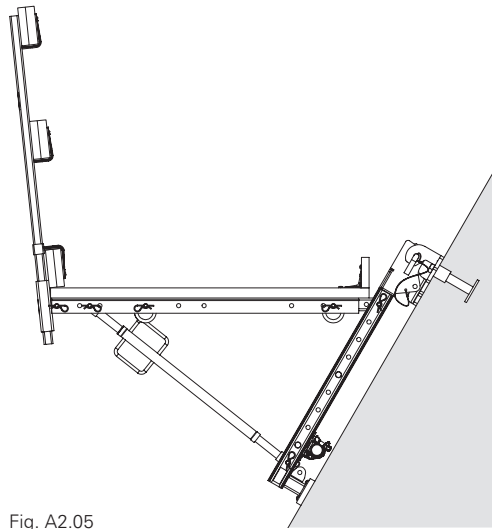

Fig. A2.05

Load case for working	
Live load on the platform	2.00 kN/m <sup>2</sup>
Max. working wind speed	0.20 kN/m <sup>2</sup> (V <sub>w</sub> = 64 km/h)

Tab. A2.06

## Storm (non-operational)

During longer work breaks or storm warnings with wind speeds > 64 km/h.



- All given loads are characteristic loads.
- Safeguarding measures, see Section "A7 Storm protection" on page 44.
- Remove loose materials and equipment.
- Do not access console brackets in storm conditions.
- For storm warnings with wind speeds > 111 km/h, inform an authorised person and implement separate safety measures.

Load case: Storm	
Live load on the platform	0.00 kN/m <sup>2</sup>
Peak velocity pressure q <sub>p</sub> (z)*	≤ 0.60 kN/m <sup>2</sup> (V <sub>w</sub> ≤ 111 km/h)

\*Max. peak velocity pressure q<sub>p</sub>(z) including reduction for temporary construction.

Tab. A2.07

## Use with full enclosure



- When installing with full enclosure, additional measures such as ballasting are required for securing. (Fig. A2.06)
- For the design of the ballasting and any additional measures required, refer to the VARIOKIT VGK design information.
- No ballasting is required when mounting with Bracing Shoe VGK (68). (Fig. A2.07)
- Affix Bracing Shoe VGK (68) with tie bolt Ø13/20x130 mm (73).
- The maximum height of the complete enclosure is to be taken from the VARIOKIT VGK design information. Higher complete enclosures must be verified on a project-specific basis.

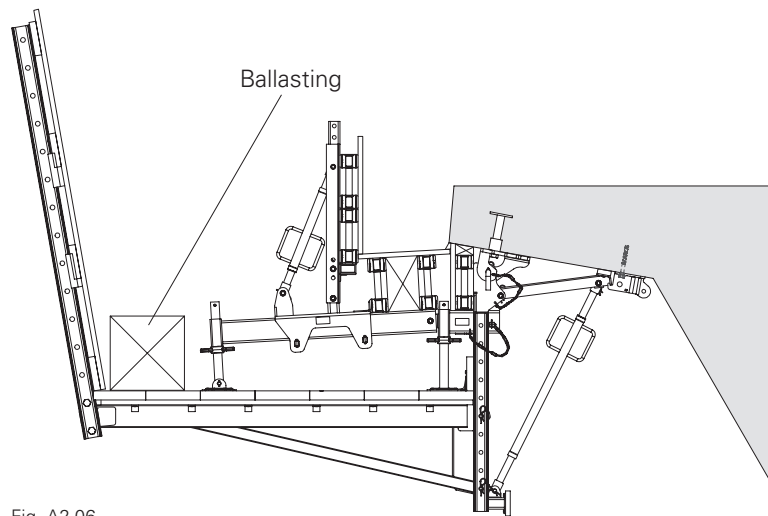

Fig. A2.06

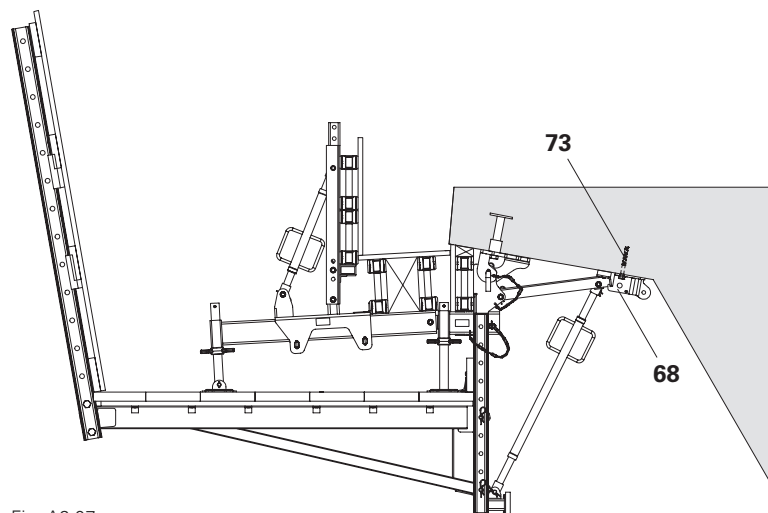

Fig. A2.07

Load case: passing train or trains passing each other	
Downwind on horizontal surfaces *)	0.50 kN/m <sup>2</sup>

\*) See DIN EN 1991-2:2010-12 6.6.3

Tab. A2.08



- The distance from the upper edge of the parapet to the lower edge of the bridge cantilever is max. 55 cm in accordance with the type calculations for both assembly types. (Fig. A3.01)
- Greater heights must be verified separately.

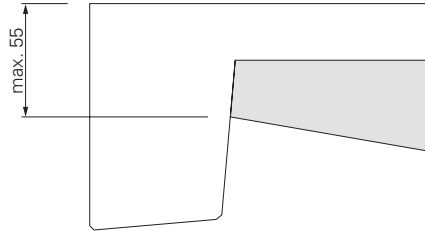

Fig. A3.01

## Cantilevered Parapet with Bracket Post VGK 70



Greater heights must be verified separately.

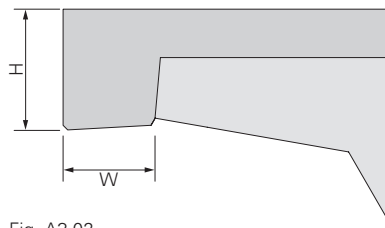

Fig. A3.02

### Dimensions

External height	$H_{\max} = 60 \text{ cm}$
Cap width	$W_{\max} = 60 \text{ cm}$

(Fig. A3.02)

### Required formwork components:

- 1a** Bracket Post VGK 70
- 2a** Kicker AV 82
- 7** Formwork Post VGK 70
- 77** Formwork Support VGK 60

(Fig. A3.03)

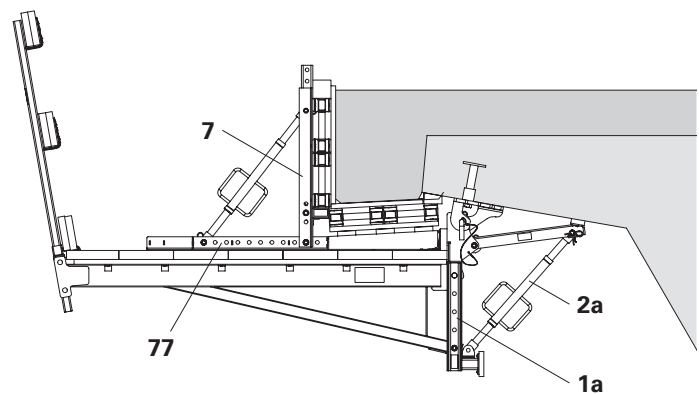

Fig. A3.03

## Cantilevered Parapet with Bracket Post VGK 110



- Ensure that relevant national guidelines and regulations in their respective current version are complied with!
- Greater heights must be verified separately.

### Dimensions

External height	$H_{max} = 60 \text{ cm}$
Cap width	$W_{max} = 60 \text{ cm}$

(Fig. A3.04)

### Required formwork components:

- 1b** Bracket Post VGK 110
- 2b** Kicker AV 111
- 5** Formwork Fixing-2 VGK
- 6** Formwork Support VGK 100
- 7** Formwork Post VGK 70
- 29** Guardrail Post-2 HSGP (optional)

(Fig. A3.05)

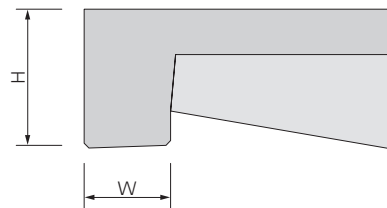

Fig. A3.04

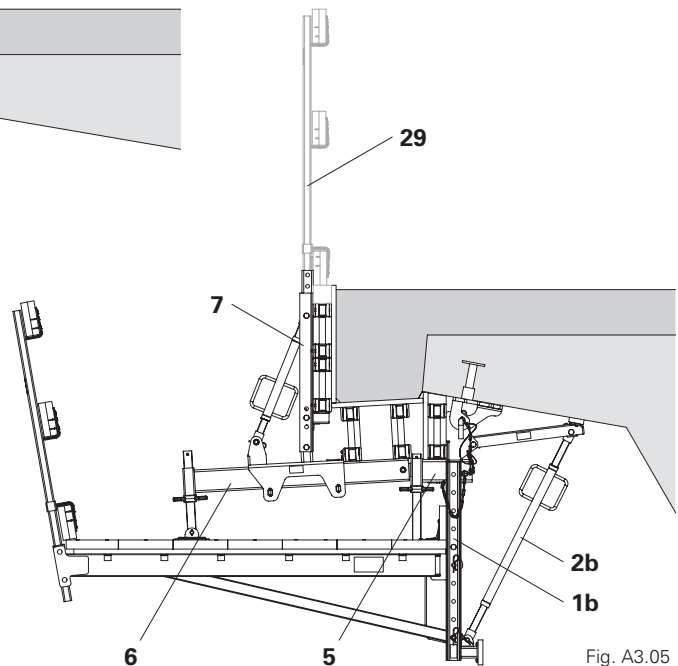

Fig. A3.05

## Cantilevered Parapet with Bracket Post VGK 139



Greater heights must be verified separately.

### Dimensions

External height	$H_{\max} = 100 \text{ cm}$
Cap width	$B_{\max} = 60 \text{ cm}$

(Fig. A3.06)

### Required formwork components:

- 1c** Bracket Post VGK 139
- 2c** Kicker AV 140
- 5** Formwork Fixing-2 VGK
- 6** Formwork Support VGK 100
- 8** Formwork Post VGK 120
- 29** Guardrail Post-2 HSGP
- 69** Girder Support coat

(Fig. A3.07)

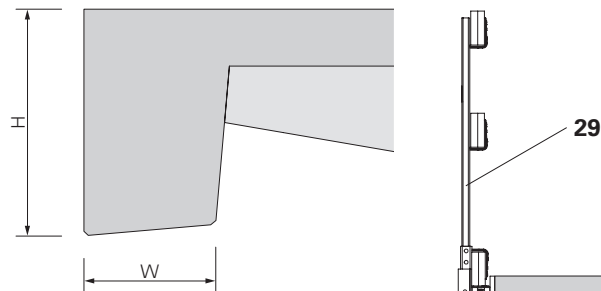

Fig. A3.06

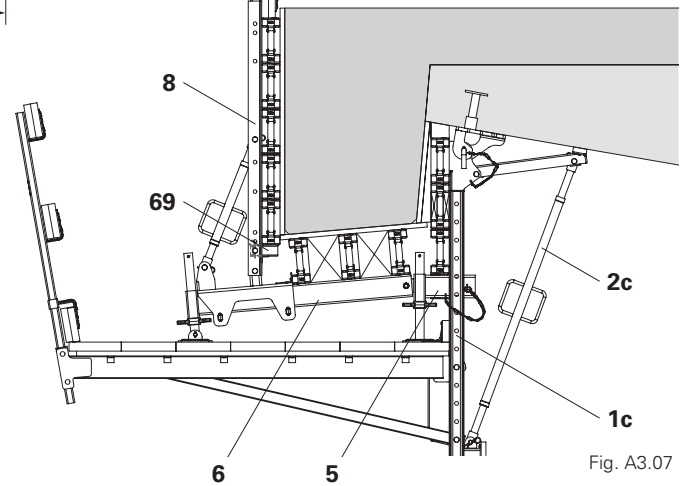

Fig. A3.07

## Work Platform VGK Flex

### VGK Flex 70

Platform with formwork post 70 and platform width 70 cm (Fig. A3.08)

Bracket Post VGK	Kicker Brace AV	$\alpha_{\min}$ [°]	$\alpha_{\max}$ [°]
110	82	60	90
	111	80	110
	140	110	110
139	82	60	70
	111	60	110
	140	80	110

Tab. A3.01

### VGK Flex 90

Platform with formwork post 120 and platform width 90 cm (Fig. A3.09)

Bracket Post VGK	Kicker Brace AV	$\alpha_{\min}$ [°]	$\alpha_{\max}$ [°]
110	82	60	70
	111	70	110
	140	100	110
139	82	60	60
	111	60	90
	140	80	110

Tab. A3.02

### VGK Flex 120

Platform with formwork post 120 and platform width 120 cm (Fig. A3.10)

Bracket Post VGK	Kicker Brace AV	$\alpha_{\min}$ [°]	$\alpha_{\max}$ [°]
110	82	–	–
	111	60	70
	140	70	100
139	82	–	–
	111	60	60
	140	60	90

Tab. A3.03



- The different combinations can be configured according to the project-specific requirements using the dimensioning tool.
- A scaffolding tube bracing is not statically necessary, but facilitates assembly and application.

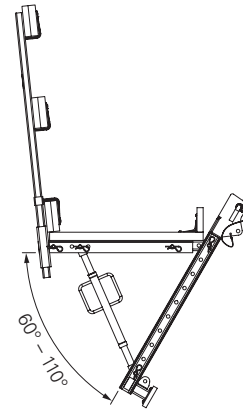

Fig. A3.08

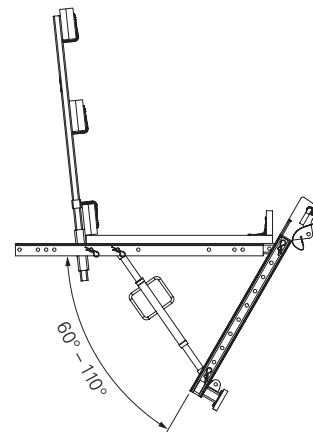

Fig. A3.09

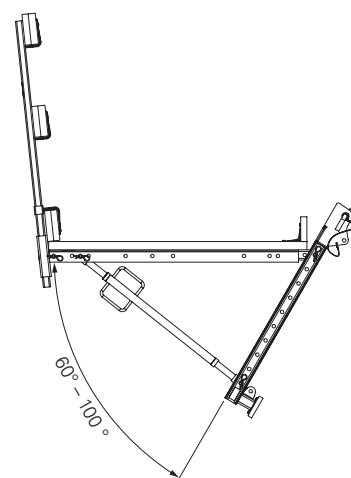

Fig. A3.10

## Cantilevered Parapet with Bracket Post VGK 70

### Assembly with Bracket Post VGK 70 and Kicker Brace AV 82

- Kicker Brace AV 82 (**2a**) is always connected to the base of Bracket Post VGK 70 (**1a**) by means of bolts and cotter pins. (Fig. A4.01)
- Adapt Tie Rod DW15 (**56**) with squared timbers (**37**). (Fig. A4.01a)
- Mount Platform Cantil. Beam VGK 170 (**4**) in the top and bottom holes of Bracket Post VGK 70 (**1a**). (Fig. A4.01)

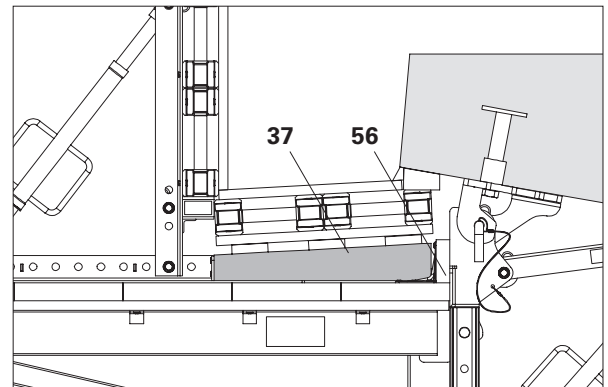

Fig. A4.01a



- Never attach Kicker Brace AV 82 (**2a**) between the fixing points of Platform Cantil. Beam VGK 170 (**4**). (Fig. A4.01b)
- Before demolition work begins or in the case of strong vibrations, secure Kicker Brace AV against unintentional turning, see Section "A10 Horizontal bracing for demolition work and strong vibrations" on page 49.

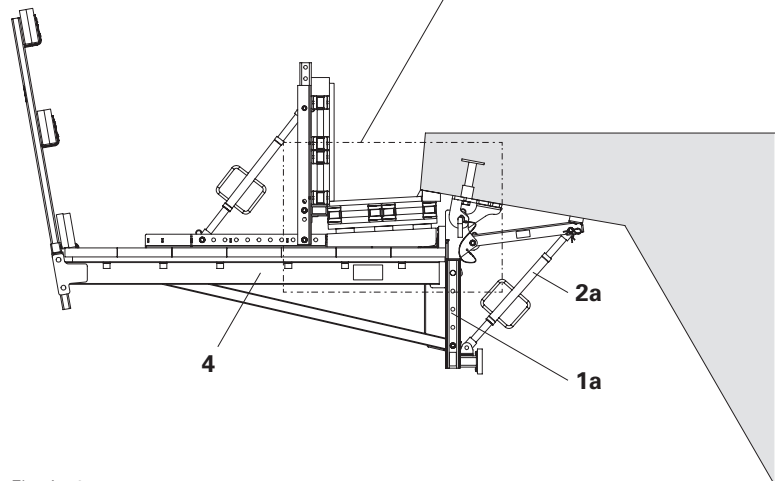

Fig. A4.01

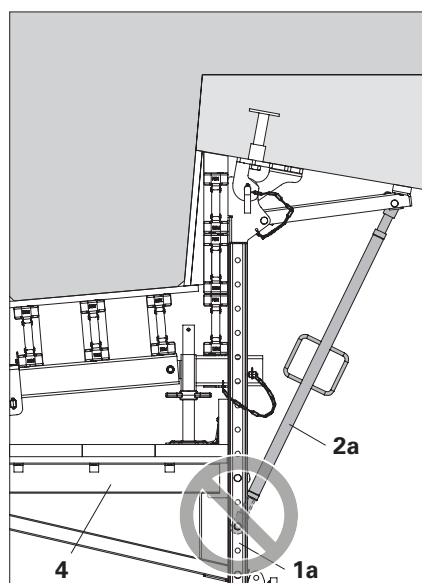

Fig. A4.01b

## Cantilevered Parapet with Bracket Post VGK 110

### Assembly with Bracket Post VGK 110 and Kicker Brace AV 111

- The Kicker Brace AV 111 (**2b**) is always fixed below the Platform Cantil. Beam VGK 170 (**4**) in the highest possible hole of the Bracket Post VGK 110 (**1b**) with bolts and cotter pins.
- Platform Cantil. Beam VGK 170 (**4**) is connected to the holes on Bracket Post VGK 110 (**1b**) according to the dimensions of the cantilevered parapet. (Fig. A4.02)



- Never attach Kicker Brace AV 111 (**2b**) between the fixing points of Platform Cantil. Beam VGK 170 (**4**). (Fig. A4.02a)
- Before demolition work begins or in the case of strong vibrations, secure Kicker Brace AV against unintentional turning, see Section "A10 Horizontal bracing for demolition work and strong vibrations" on page 49.



Keep the extension of the Adj. Base Plate UJB 38 mm-80/55 (**9**) as small as possible, allow spindle travel for deshuttering.

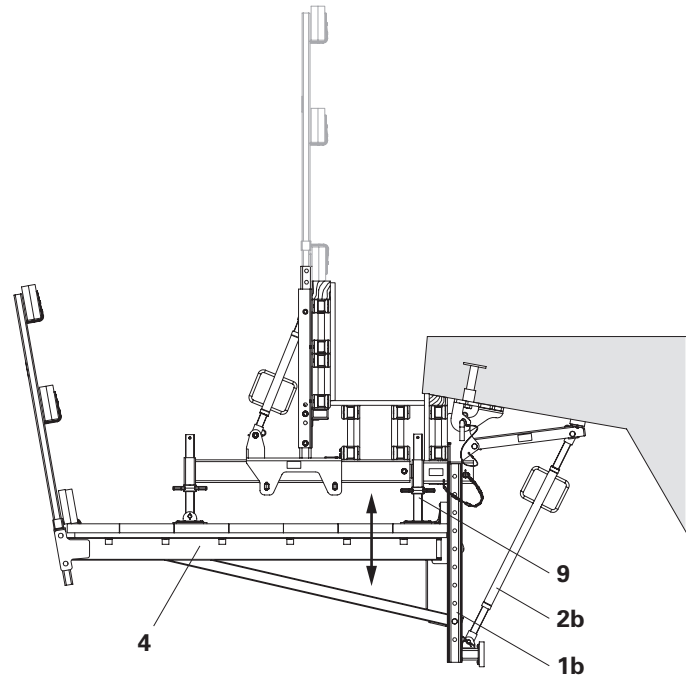

Fig. A4.02

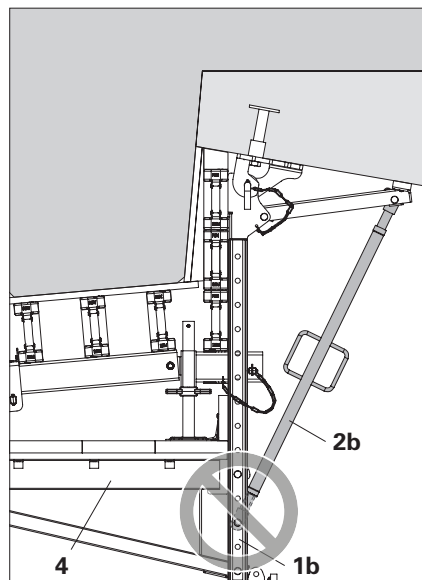

Fig. A4.02a



## Cantilevered Parapet with Bracket Post VGK 139

### Assembly with Bracket Post VGK 139 and Kicker Brace AV 140

- The Kicker Brace AV 140 (**2c**) is always fixed below the Platform Cantil. Beam VGK 170 (**4**) in the highest possible hole of the Bracket Post VGK 139 (**1c**) with bolts and cotter pins.
- Platform Cantil. Beam VGK 170 (**4**) is connected to the holes on Bracket Post VGK 139 (**1c**) according to the dimensions of the cantilevered parapet. (Fig. A4.03)



- Never attach Kicker Brace AV 140 (**2c**) between the fixing points of Platform Cantil. Beam VGK 170 (**4**). (Fig. A4.03a)
- Before demolition work begins or in the case of strong vibrations, secure Kicker Brace AV against unintentional turning, see Section "A10 Horizontal bracing for demolition work and strong vibrations" on page 49.



Keep the extension of the Adj. Base Plate UJB 38 mm-80/55 (**9**) as small as possible, allow spindle travel for deshuttering.

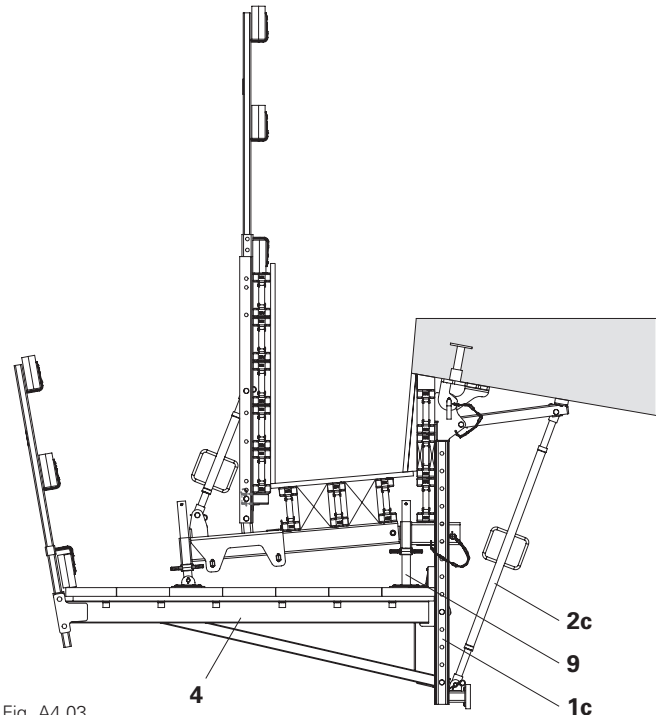

Fig. A4.03

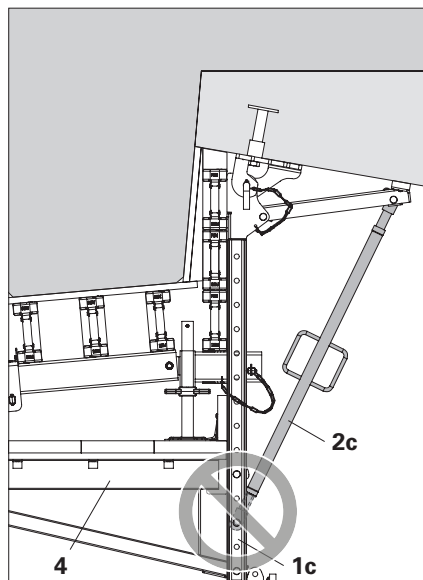

Fig. A4.03a

## Work Platform VGK Flex

### Assembly with Formwork Post VGK 70 and platform width 70 cm



- Guardrail Holder VGK (62) is always used on the 1<sup>st</sup> and 3<sup>rd</sup> hole of Formwork Post VGK 70 (7).
  - Kicker Brace AV (2a/2b/2c) is always bolted in the 3<sup>rd</sup> hole.
- (Fig. A4.04 + Fig. A4.04a)

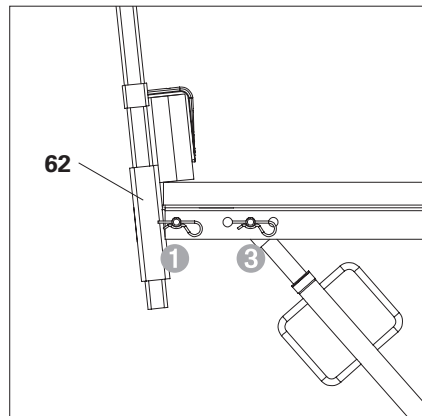

Fig. A4.04a

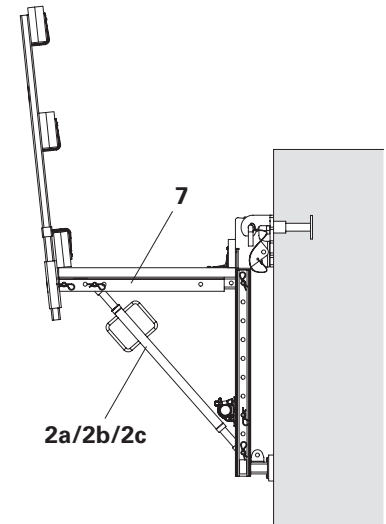

Fig. A4.04

### Assembly with Formwork Post VGK 120 and platform width 90 cm



- Guardrail Holder VGK (62) is always used on the 5<sup>th</sup> and 6<sup>th</sup> hole of Formwork Post VGK 120 (8).
  - Kicker Brace AV (2a/2b/2c) is always bolted in the 6<sup>th</sup> hole.
- (Fig. A4.05 + Fig. A4.05a)

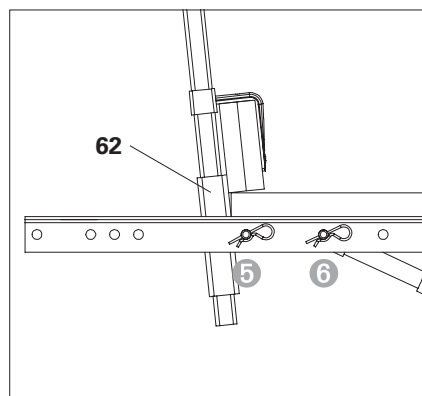

Fig. A4.05a

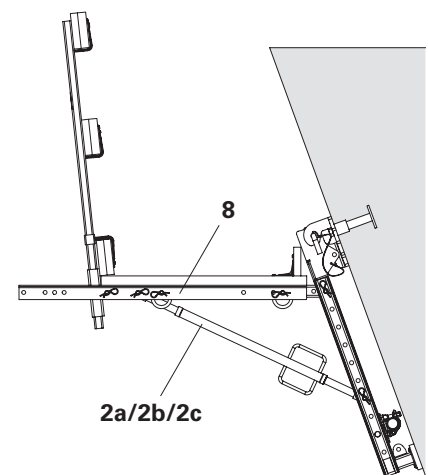

Fig. A4.05

### Assembly with Formwork Post VGK 120 and platform width 120 cm



- Guardrail Holder VGK (62) is always used on the 1<sup>st</sup> and 3<sup>rd</sup> hole of Formwork Post VGK 120 (8).
  - Kicker Brace AV (2a/2b/2c) is always bolted in the 3<sup>rd</sup> hole.
- (Fig. A4.06 + Fig. A4.06a)

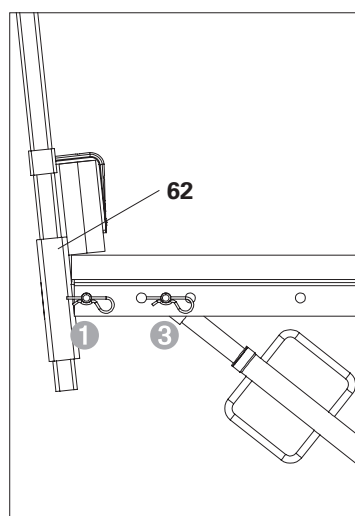

Fig. A4.06a

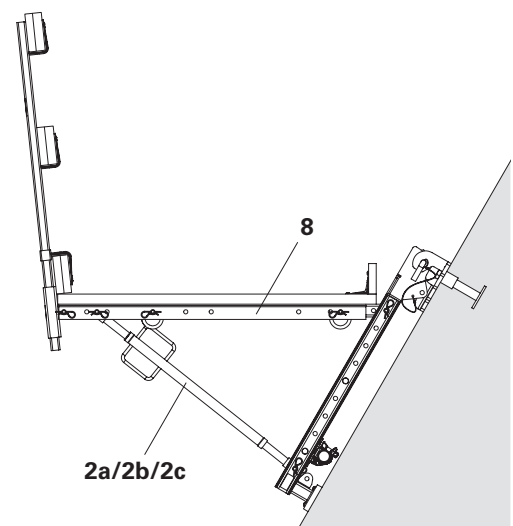

Fig. A4.06

## Assembly with Bracket Post VGK 110



Kicker Brace AV (**2a/2b/2c**) may only be bolted into the lower **four** holes of Bracket Post VGK 110 (**1b**).  
(Fig. A4.07 + Fig. A4.07a)

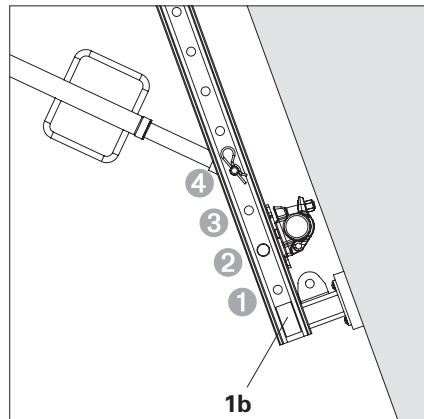

Fig. A4.07a

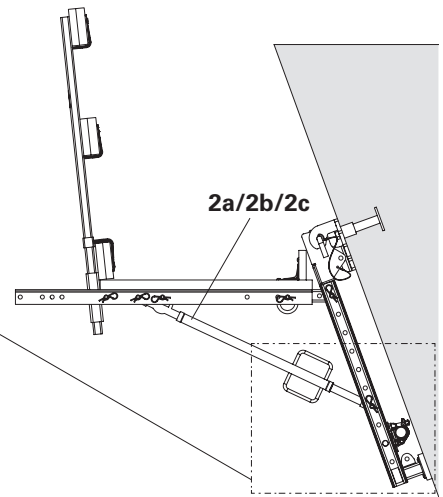

Fig. A4.07

## Assembly with Bracket Post VGK 139



Kicker Brace AV (**2a/2b/2c**) may only be bolted into the lower **four** holes of Bracket Post VGK 139 (**1c**).  
(Fig. A4.08 + Fig. A4.08a)

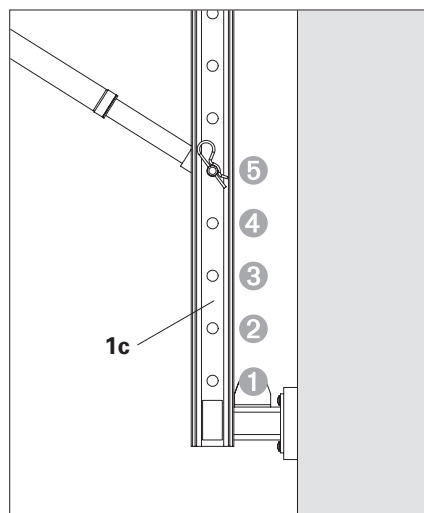

Fig. A4.08a

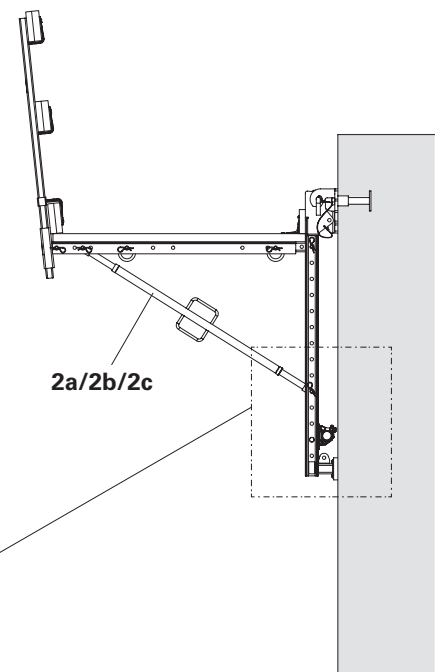
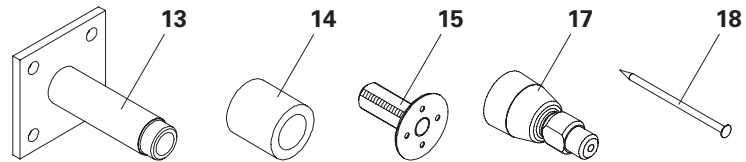

Fig. A4.08

## On the cantilever (new structures)

### Anchor Sleeve M24

Anchor Sleeve M24 is also embedded when concreting the cantilevered parapet.



### Required components per tie point:

<b>13</b> Anchor Sleeve M24	1x
<b>14</b> Cone FRC 32/52 mm C=40 mm	1x
<b>15</b> Anchor Position. M24x65 mm	1x
<b>41</b> Wire nail 3x80 mm	4x
Alternatively:	
<b>17</b> Threaded Cone M24 40 mm	1x
<b>18</b> Wire nail 4.6x130 mm	1x



- Constructional requirements for use of Anchor Sleeve M24 with cantilevered parapet systems, see design information for the VARIOKIT VGK.
- Permissible widths of influence on cantilevers: see design information for the VARIOKIT VGK.
- Keep thread of Anchor Sleeve M24 free of rust and dirt.

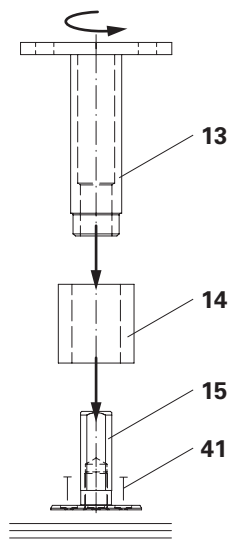

Fig. A5.01

### Installation with anchor positioning stud

1. Fix Anchor Position. M24x65 mm ga (**15**) to the formwork panel by means of four wire nails 3x80 mm (**41**). Take into consideration edge spacing "a" (Fig. A5.01 + Fig. A5.01a)
2. Push Cone FRC 32/52 mm C=40 mm (**14**) over the thread of Anchor Position. M24x65 mm (**15**).
3. Screw Anchor Sleeve M24 (**13**) onto the Anchor Position. M24x65 mm (**15**) as far as it will go. (Fig. A5.01)
4. Secure Anchor Sleeve M24 (**13**) in the reinforcement using tie wire.

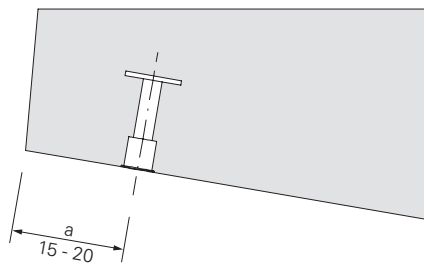

Fig. A5.01a

## Installation with threaded cone

1. Check anchor installation components for signs of damage and replace if necessary.
2. Insert the wire nail 4.6x130 mm **(18)** into the Threaded Cone M24/40 mm **(17)**.
3. Position Threaded Cone M24 40 mm **(17)** on the formlining and hammer in wire pin 4.6x130 mm all the way **(18)**. (Fig. A5.02)
4. Screw in Anchor Sleeve M24 **(13)** as far as possible, at 90° to the formwork panel. (Fig. A5.03)
5. Secure Anchor Sleeve M24 **(13)** in the reinforcement with tie wire to ensure that it does not change its position during concreting.

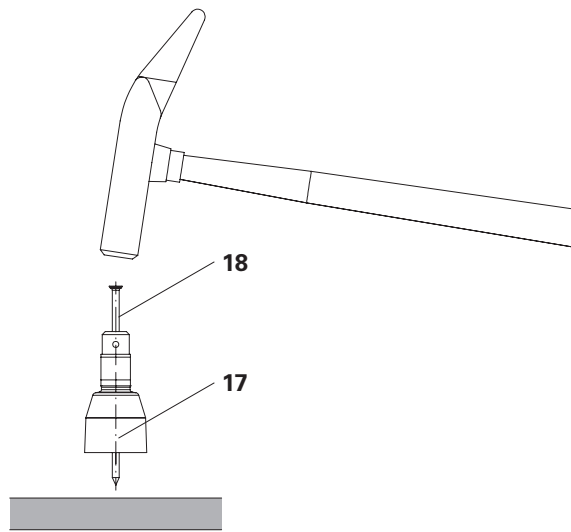

Fig. A5.02



## Check installation

- Edge distance
  - Distance to each other
  - Ensure the anchor sleeve is completely screwed in
  - Planned position
- Tie and reinforcement checks can be done at the same time.



Carefully grease the surfaces of the cones that come into contact with concrete and the thread with a suitable grease.  
This simplifies the process of removing the recoverable cones.

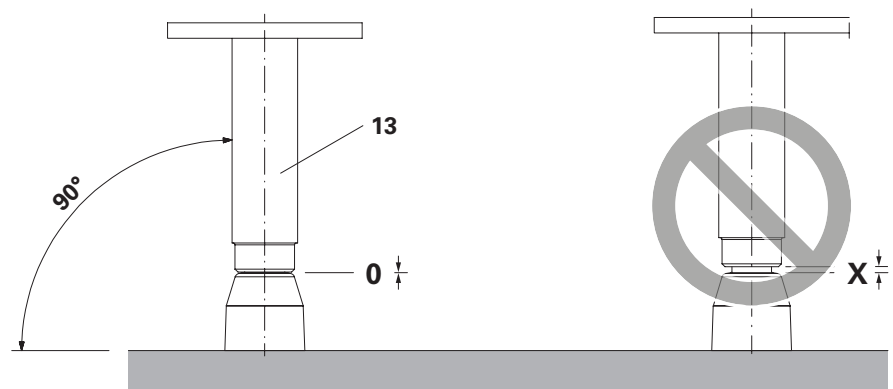

Fig. A5.03

## On abutment or wall

### Screw-On Cone-2 M24/DW20

The screw-on cone is also embedded when concreting the abutment.

### Anchor Sleeve M24

The anchor sleeve is also embedded when concreting the abutment.

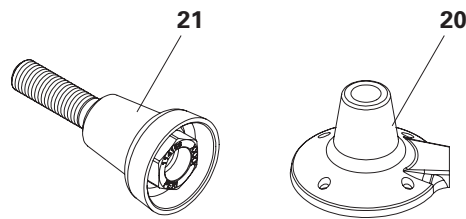

### Required components per tie point

<b>20</b> Threaded Anchor Plate DW20	1x
<b>21</b> Screw-On Cone-2 M24/DW20	1x
or	
<b>13</b> Anchor Sleeve M24	1x
<b>14</b> Cone FRC 32/52 mm C=40 mm	1x
or	
<b>13</b> Anchor Sleeve M24	1x
<b>74</b> Cone PP Ø31/26 mm C=25 mm	1x

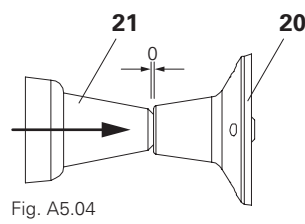

Fig. A5.04

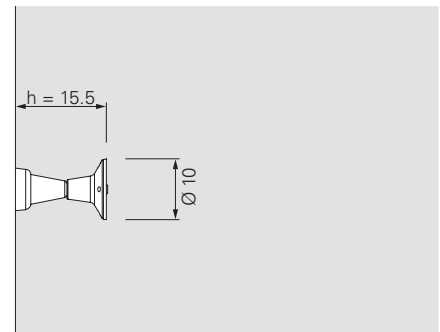

Fig. A5.04a



- Design requirements, see design information for VARIOKIT VGK.
- Permissible widths of influence on abutment, design information for VARIOKIT VGK.

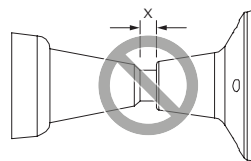

Fig. A5.04b

### Screw-on cone assembly

1. Fully insert Screw-On Cone-2 M24/DW20 (**21**) into Threaded Anchor Plate DW20 (**20**). (Fig. A5.04a)  
Anchoring depth  $h = 15.5$  cm. (Fig. A5.04a)



### Check installation

- Distance to each other
- Anchor sleeve fully screwed in (Fig. A5.04 + Fig. A5.04b)
- Planned position

Tie and reinforcement checks can be done at the same time.



Carefully grease the surfaces of the cones that come into contact with concrete and the thread with a suitable grease.

This simplifies the process of removing the recoverable cones.

## Fixing with Anchor Posit. Stud M24 ga

### Assembly

1. Fix Anchor Posit. Stud M24 (**22**) to the marked position with four wire nails 3x80 mm (**41**). Take into consideration the minimum distance to the edge. (Fig. A5.05)
2. Tightly screw pre-assembled ties (**20 + 21**) onto Anchor Posit. Stud M24 (**22**) and tighten. (Fig. A5.06)
3. Firmly connect Threaded Anchor Plate DW20 (**20**) to the reinforcement to ensure a secure position.

or

2. Fit Cone FRC 32/52 mm C=40 mm (**14**) onto Anchor Position. M24x65 mm (**15**).

3. Screw Anchor Sleeve M24 onto Anchor Position. M24x65 mm (**15**) and tie it to the reinforcement to secure the position. (Fig. A5.07)

or

2. In the case of low concrete cover, fit Cone PP Ø31/26 mm C=25 mm (**74**) onto Anchor Position. M24x65 mm (**15**).

3. Screw Anchor Sleeve M24 onto Anchor Position. M24x65 mm (**15**) and tie it to the reinforcement to secure the position. (Fig. A5.08)

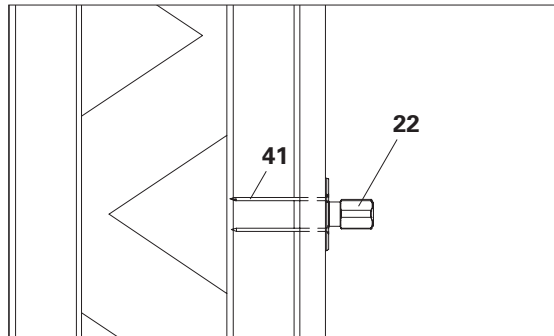
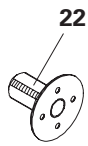

Fig. A5.05

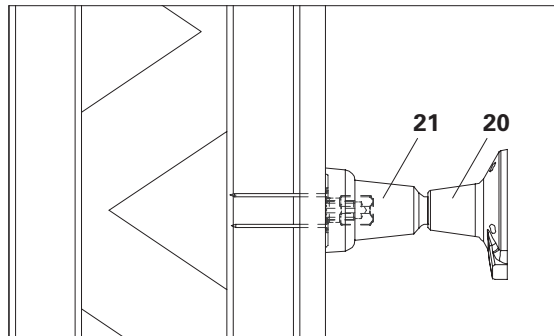

Fig. A5.06

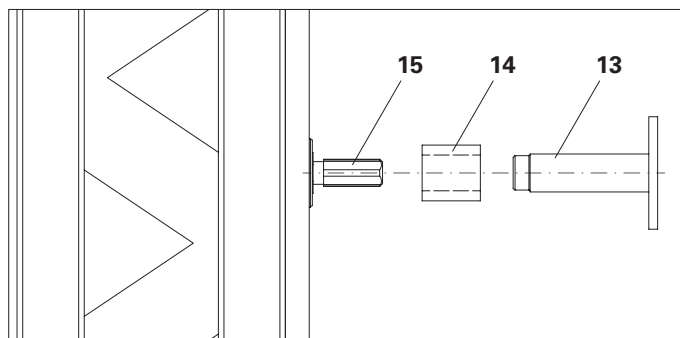

Fig. A5.07

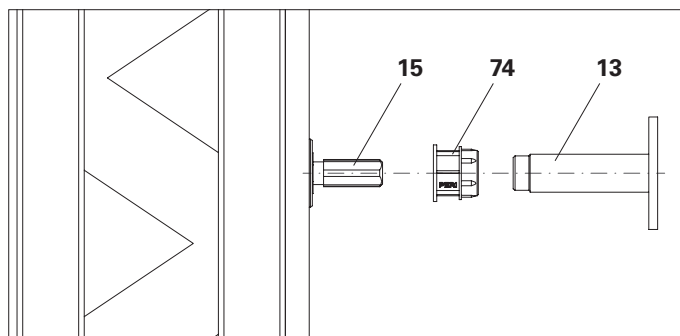

Fig. A5.08



### Checking assembly

- Height
- Distance to each other
- Anchoring depth h
- Alignment according to specifications

Tie and reinforcement checks can be done at the same time.



- A more stable fixing is achieved through installation of the tie positioning plate, see A5 "Assembly of Advancing Screw M24 ga".
- In this case, the distances from the holes to be drilled to the steel struts or beams of the formwork must be large enough.

## Fixing with Advancing Screw M24 ga

### Preparation

1. Check the required space for the Anchor Posit. Plate M24 ga (**45**). Lateral spacings of 3 cm or 4 cm are required.
2. Measure and drill a hole  $\varnothing$  25 mm from the front of the formwork. (Fig. A5.09)
3. Attach Anchor Posit. Plate M24 ga (**45**) to the formlining with 4x Hex-Wood-Screw 6x20 DIN571-ga (**47**). (Fig. A5.10)

### Assembly

1. Insert Advancing Screw M24 (**46**) from the rear side of the formlining through the hole.
2. From the front side of the formlining, tightly screw on the tie (**20 + 21**). (Fig. A5.11)
3. Firmly connect Threaded Anchor Plate DW20 (**20**) to the reinforcement to ensure a secure position.

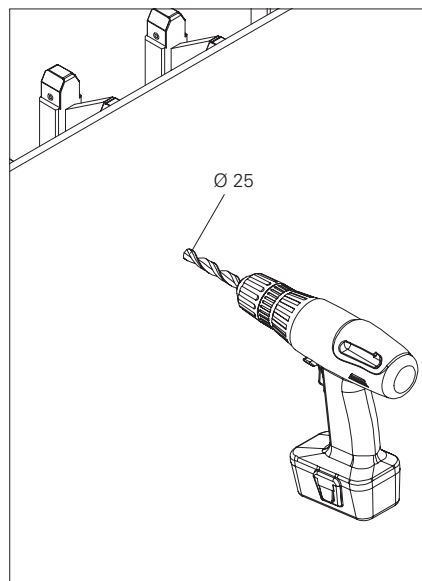
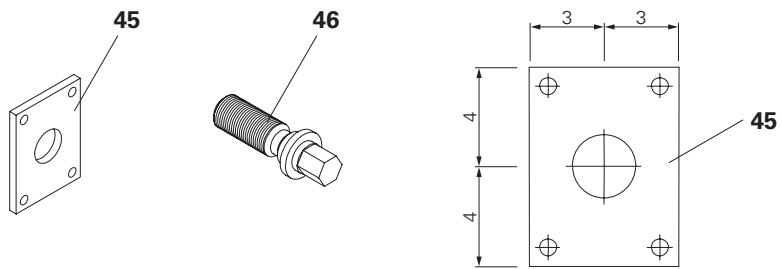

Fig. A5.09

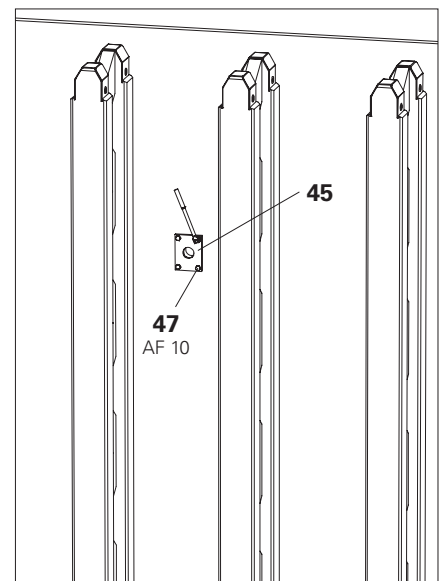

Fig. A5.10



### Checking assembly

- Height
- Distance to each other
- Anchoring depth h
- Alignment according to specifications

Tie and reinforcement checks can be done at the same time.



If there is a formwork girder positioned at the rear of the tie point, "Assembly with Anchor Posit. Stud M24 ga" can be used.

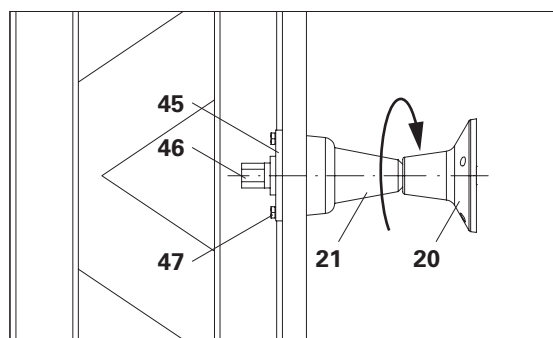

Fig. A5.11



## Alternative anchoring

For anchorage on alternative anchoring (according to General Building Inspectorate Approval no. Z-21.6-1764)

### Required components per tie point:

<b>12a</b>	Suspension Head VGK Flex	1x
<b>28</b>	Anchor VGK B15	1x
Alternatively:		
<b>12b</b>	Suspension Head VGK	1x
<b>27</b>	Anchor Lock VGK B15	1x
<b>28</b>	Anchor VGK B15	1x

### Assembly of Suspension Head Flex VGK

1. Insert Anchor VGK B15 (**28**) through Suspension Head VGK Flex on the slot side (**12a**), screw on but do not tighten. (Fig. A5.12b)
  2. Push Suspension Head VGK Flex (**12a**) into position and tighten Anchor VGK B15 (**28**). (Fig. A5.12c)
- (Fig. A5.12 + Fig. A5.12a)

### Assembling Suspension Head VGK

1. Tighten Suspension Head VGK (**12b**) with Anchor VGK B15 (**28**).
  2. Secure Anchor VGK B15 (**28**) with Anchor Lock VGK B15 (**27**) to prevent rotation.
- (Fig. A5.13 + Fig. A5.13a)

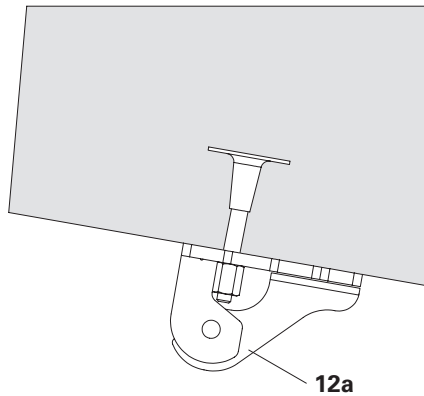

Fig. A5.12

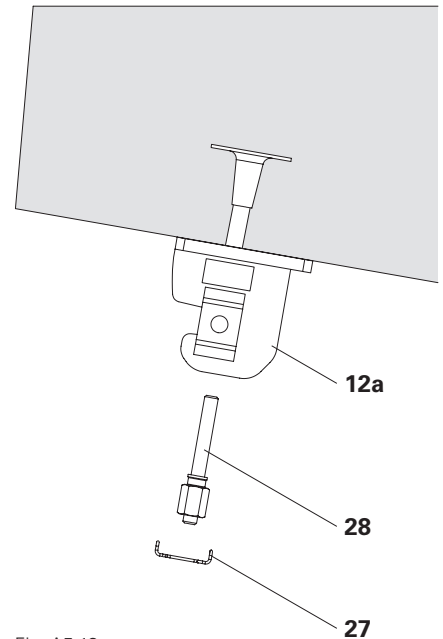

Fig. A5.13

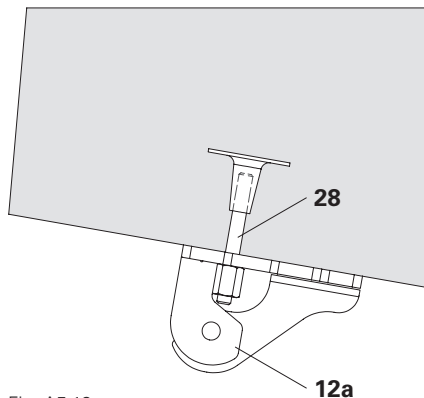

Fig. A5.12a

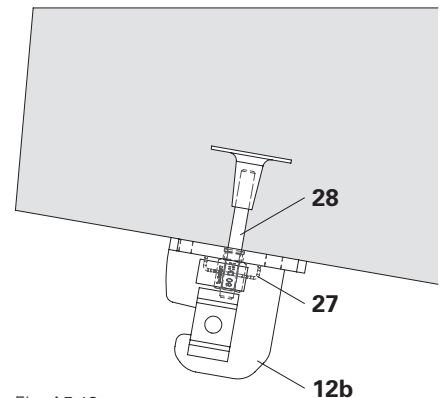

Fig. A5.13a



### Checking assembly

- Alignment according to specifications

Tie and reinforcement checks can be done at the same time.



Close the hole after use using filler mortar.

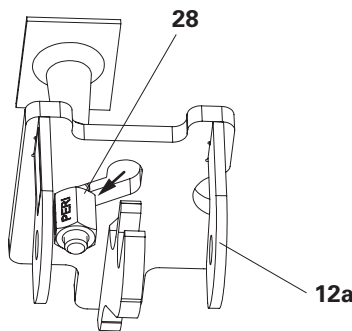

Fig. A5.12b

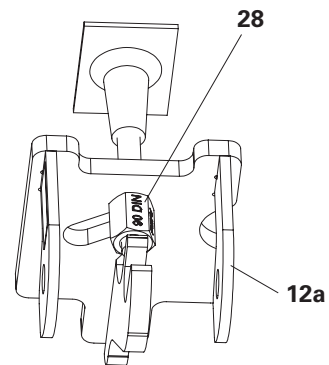

Fig. A5.12c

## Removal and closure



### Danger

Leading edges are present during assembly!

There is a risk of falling off the cantilevered parapet.

⇒ The removal and closure of the tie holes takes place from a safe and secure working area, e.g.:

- Telescopic work platform.
- Temporary working scaffold.
- Personal protective equipment to prevent falling from a height (PPE).

### Dismantling on the cantilever

1. Loosen screw ISO 4014-M24x 100-8.8 (16) in Suspension Head VGK (12).
2. Remove Suspension Head VGK (12).

### Closure

1. Clean tie hole.
2. Mix repoxal glue (31) according to the manufacturer information.
3. Dip the concrete plug Ø32 mm (19b) for the Anchor Posit. Stud M24 ga or Ø40 mm (19a) for the threaded cone M24 into the repoxal glue (31) on one side.
4. Tap the concrete plug (19) flush into the tie hole with a rubber mallet.
5. Remove adhesive residue with a spatula. (Fig. A5.14 + Fig. A5.14a)

19a – Ø 40 mm  
19b – Ø 32 mm

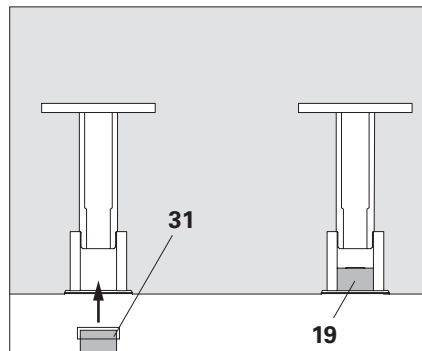

Fig. A5.14

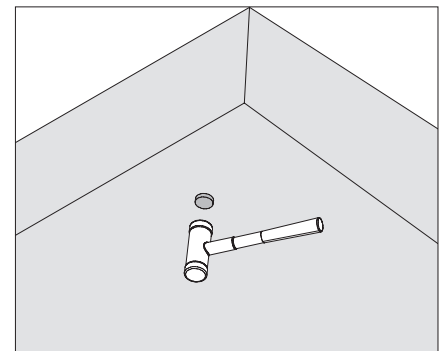

Fig. A5.14a

## Dismantling on the abutment

1. Loosen screw ISO 4014-M24x 070-10.9 (23) in Suspension Head VGK (12).
2. Remove Suspension Head VGK (12).
3. Release Screw-On Cone-2 M24/ DW20 (21) using socket wrench AF 36.
4. Unscrew Screw-On Cone-2 M24/ DW20 (21) by hand. (Fig. A5.15 + Fig. A5.16)

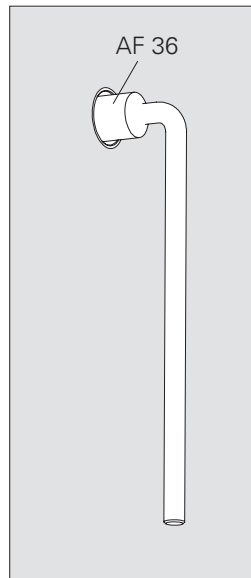

Fig. A5.15

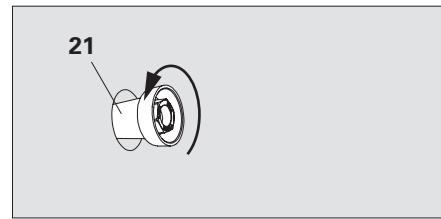

Fig. A5.16

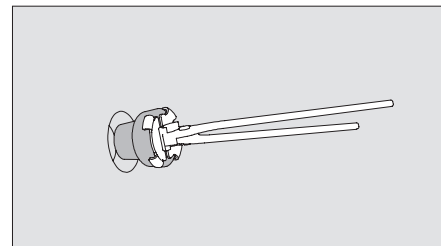

Fig. A5.17

## Closure

1. Clean tie hole.
2. Close the tie hole with a suitable cone, e.g. PERI Concrete Cones. (Fig. A5.17)



Observe user information for concrete cones with Sealing Compound-3.



For architectural concrete, the tie holes can be closed with PERI Sealing Cones KK.

## Refurbishment on the cantilever



### Danger

The full load-bearing capacity is reached after the composite mortar has hardened!

The cantilevered parapet bracket can fall.

⇒ Access the cantilevered parapet bracket only after the concrete has hardened.

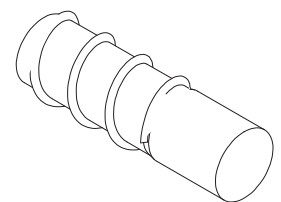
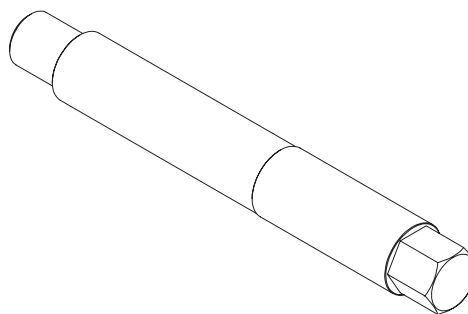

Observe safety data sheet.

## Preparing drilled hole

1. Ensure that the drilled hole is at right angles to the concrete surface. Drill hole depth 160 mm,  $\varnothing$  22 mm.
2. Check the depth of the drilled hole.
3. Blow out the drilled hole with the blow-out pump (48) from below.
4. Brush out the drilled hole with Cleaning Brush D24 (49) at least 4 times.
5. Blow out the drilled hole with the blow-out pump (48) from below.

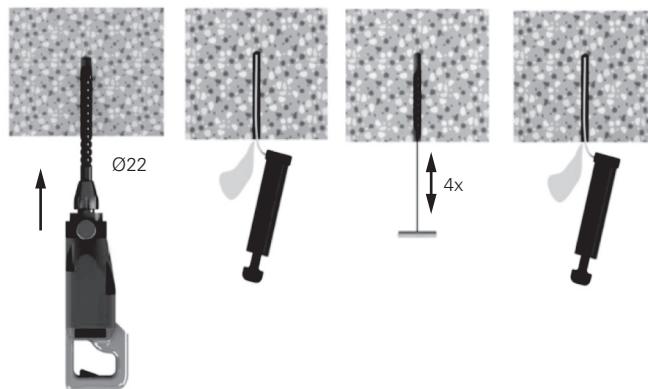

## Mounting refurbishment anchor

1. Inject Composite Mortar CF-T 300 V (50).
2. Screw Connection Bolt M16/ M24x50 (51) and ITH-Sleeve TSM BC 22x75 mm IM16 (52) together tightly.
3. Screw the unit into the drilled hole with an impact wrench (nominal torque 600 Nm). (Fig. A5.18)
  - After reaching the designated screw-in depth, the composite mortar must appear on the concrete surface.
  - The embedment mark is the start of the thread on the M24.
  - VGK assembly loads can be immediately accommodated.
7. Fit Suspension Head VGK with Hex-Nut ISO 7040-M24-8-ga (24).

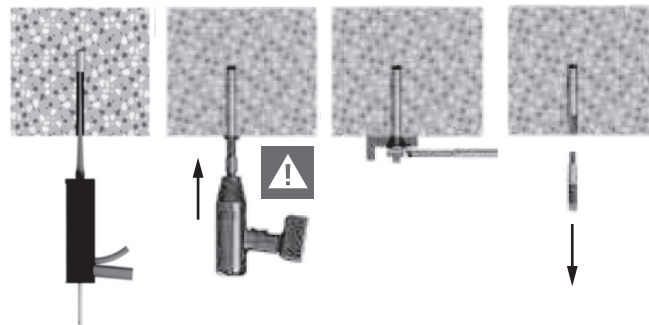

## Disassembly

1. Unscrew Connection Bolt M16/ M24x50 (51) after use. (Fig. A5.19)
2. Close the drilled hole.

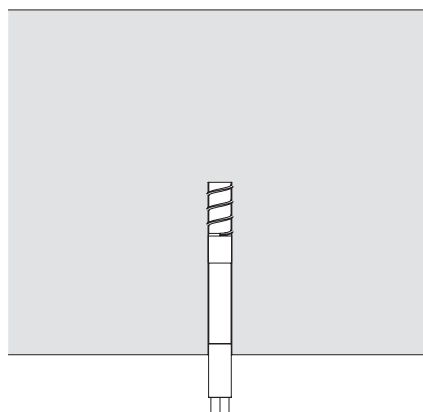

Fig. A5.18

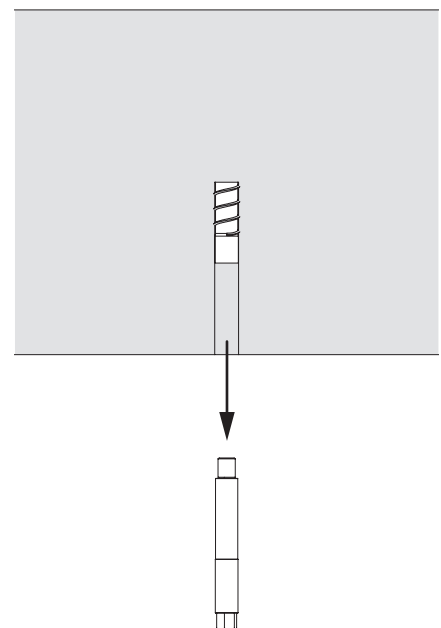

Fig. A5.19





Take into consideration country-specific standards and regulations.

## Platform decking

Planking according to EN 12811 and DIN 4420-1 respectively.

- Planking (35) spans a minimum of two bays, with offset joints.
- Fit planking onto each platform beam with Wood-Screws 6x80 SK-TX30 HPI (39). (Fig. A6.01 + Fig. A6.02)
- When mounting the platform on the floor, only a multi-layer plywood sheet can be used as deck (cantilever =  $c/2$ , max. 75 cm). (Fig. A6.03)
- Multi-layer wood sheet thickness of at least 39 mm.
- Secure cantilevered planking against lifting.
- With installation according to DIN 4420-1 Table 3, planking can be used as a cover which is suitable to catch falling objects. Ensure tightness.

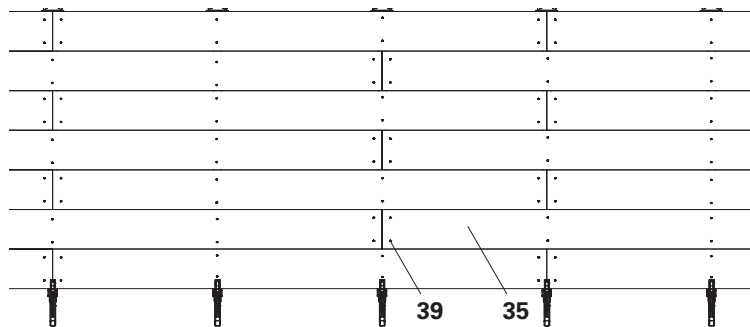

Fig. A6.01

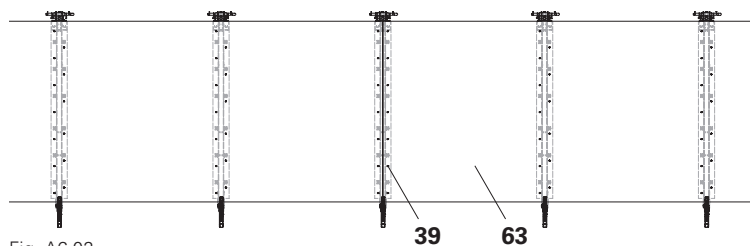

Fig. A6.02

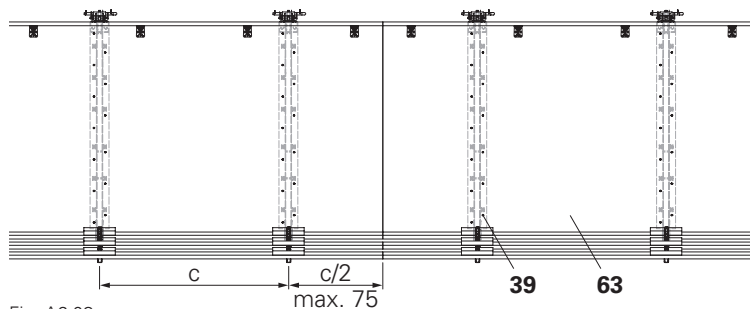

Fig. A6.03

## Safety scaffold

In the absence of safety measures against falling and fall heights  $h > 1.00$  m at the edge of the bridge, the planking is to be installed as safety decking according to DIN 4420-1.

- Installation of planking depending on the fall height  $h$  and span in accordance with DIN 4420-1, Table 2. (Fig. A6.04)
- Depending on the span, it may be necessary to double the thickness.

### For planking widths $>24$ cm and fall heights $h \leq 1.50$ m:

Planking thickness	max. span
4.0 cm	1.00 m
5.0 cm	1.30 m
Double thickness	
2 x 4.0 cm	1.60 m
2 x 5.0 cm	2.20 m

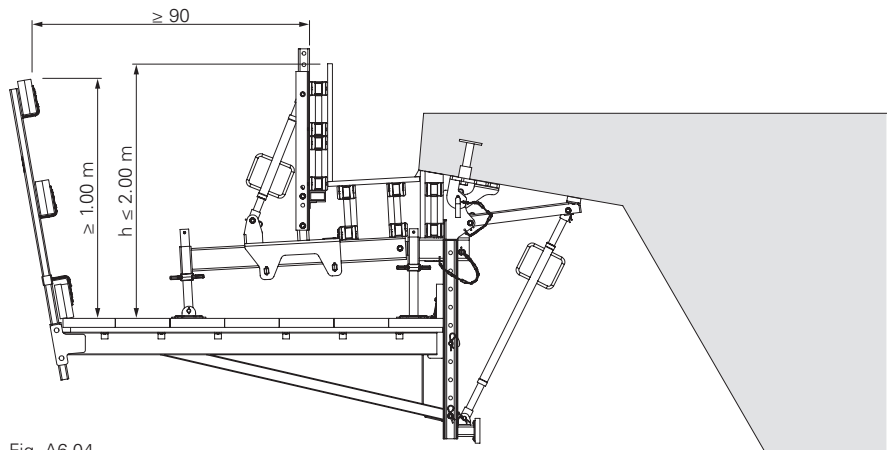

Fig. A6.04

## Lateral protection

Guardrails are to be mounted on the working scaffold according to EN 12811.

- Fix guardrail boards (33) and toe boards (34) to Guardrail Posts-2 HSGP (29) with wire pins or wood screws (36). (Fig. A6.05)
- Alternatively, Guardrail Post SGP (67) can be fitted instead of Guardrail Post-2 HSGP (29).
- Alternatively, Lateral Protection Barriers PMB can be used instead of guardrails and toe boards. (Fig. A6.06)
- Lateral protection or full enclosure is only possible with the use of VGK Flex with Guardrail Post -2 HSGP (29).
- In case of partial or complete enclosure of the lateral protection or use with Guardrail Post SGP (67), the permissible influence width of the guardrail post may limit the bracket spacing.

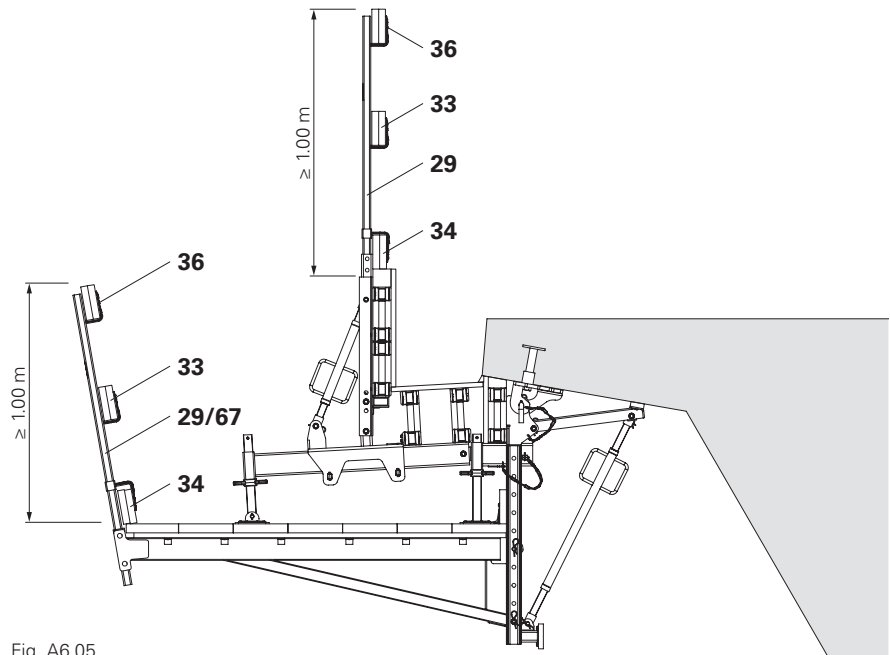

Fig. A6.05



Observe the design information.

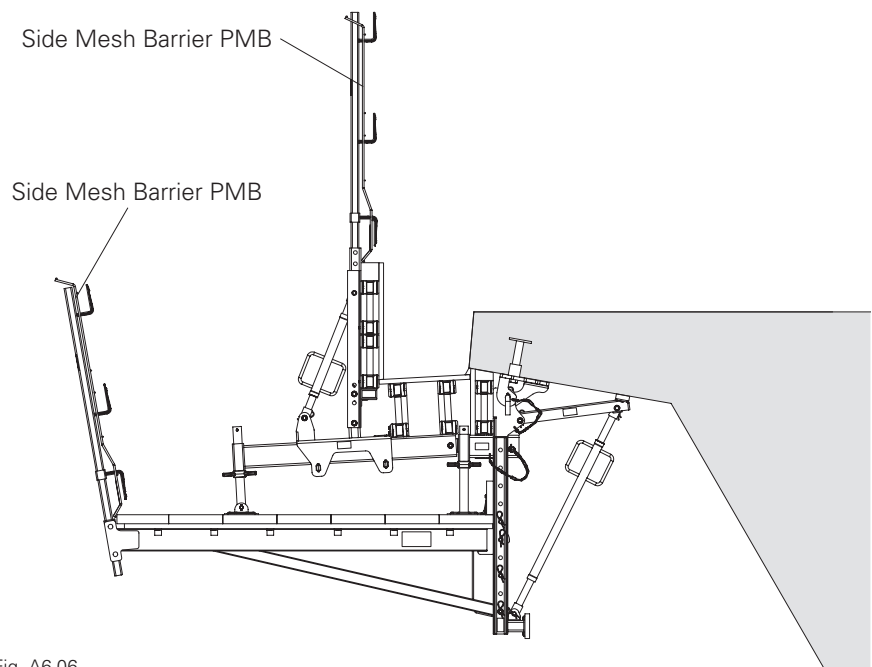

Fig. A6.06

## Use as formwork scaffolding



In case of a storm, Console Bracket VGK must be free of materials and tools as well as be secured against tipping. Example using squared timbers (37).

Refer to the relevant design information for storm protection measures for complete enclosures or alternative storm protection measures.

## Cantilever

(Fig. A7.01)

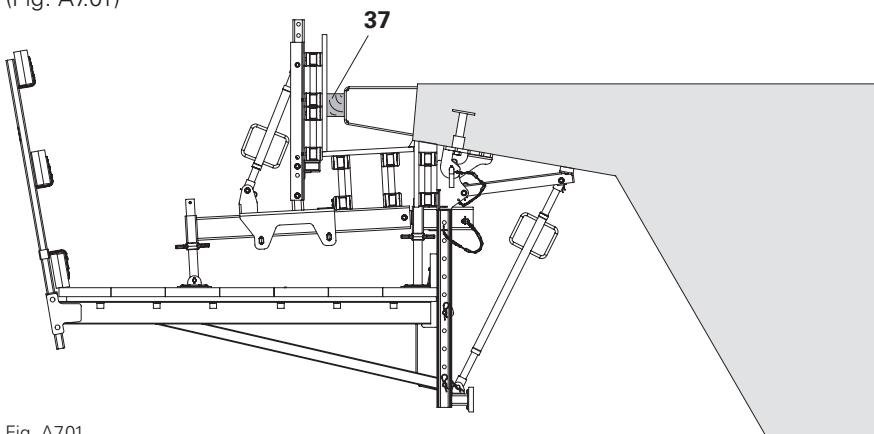

Fig. A7.01

## Vertical application on abutments

(Fig. A7.02 + Fig. A7.03)

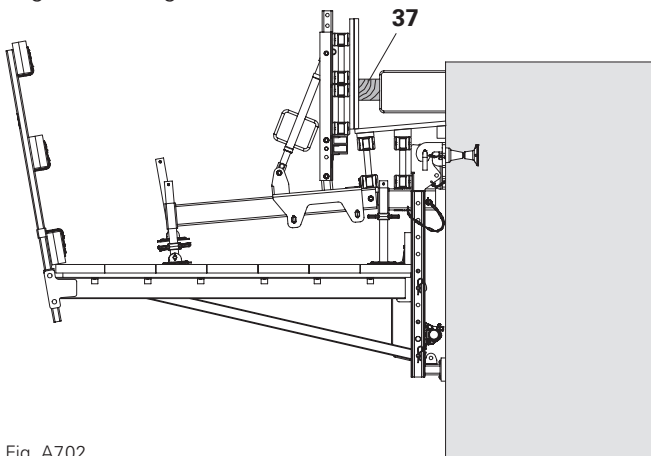

Fig. A7.02

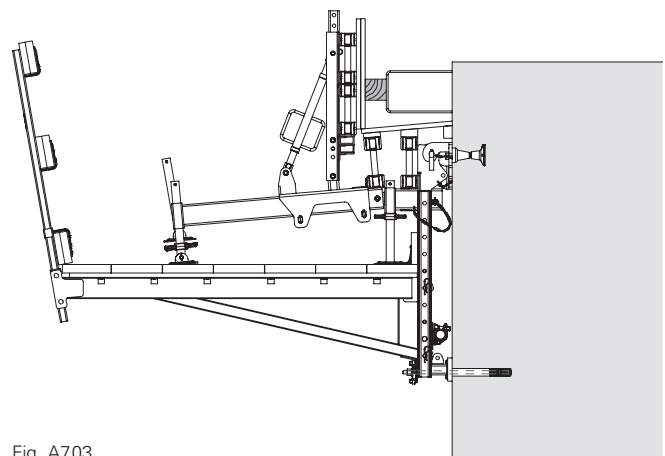

Fig. A7.03



## Use as work platform

In case of a storm, Console Bracket VGK must be free of materials and tools as well as be secured against tipping. Example using squared timbers (37).



Refer to the relevant design information for storm protection measures for complete enclosures or alternative storm protection measures.

## Cantilever

(Fig. A7.04)

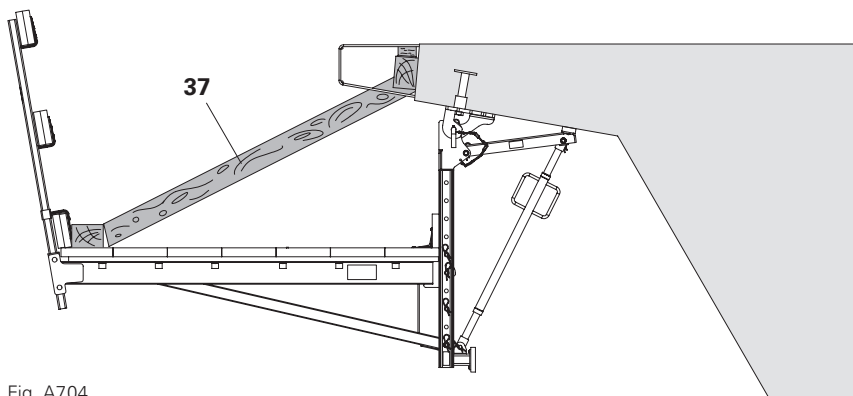

Fig. A7.04

## Vertical application on abutments

(Fig. A7.05 + Fig. A7.06)

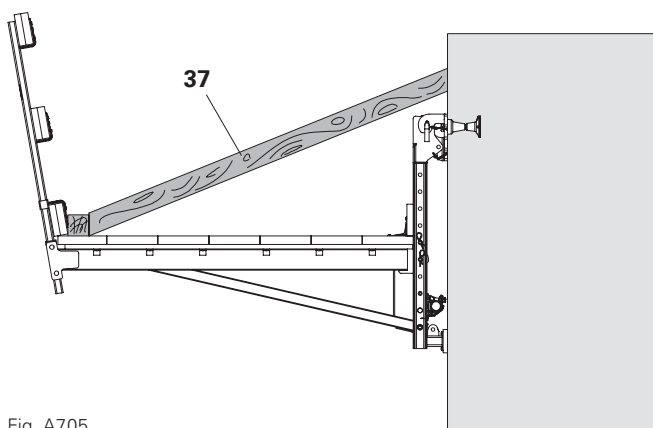

Fig. A7.05

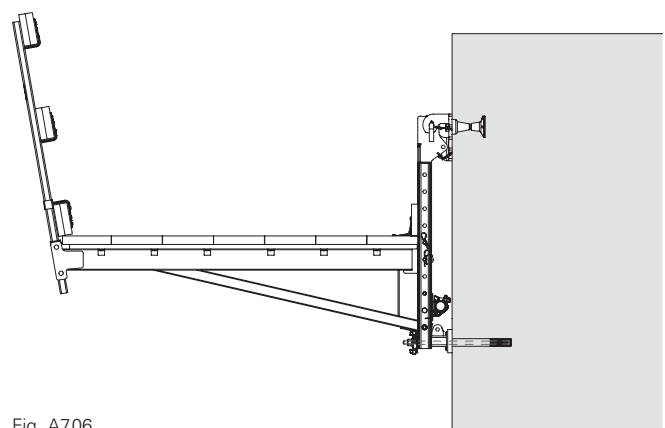

Fig. A7.06

## On the cantilever



- For horizontal bracing, the console brackets are always connected in pairs to the scaffolding tubes and diagonal planking.
- The diagonally-positioned plank (**38**) is force-locked against Bracket Post VGK in the direction of the longitudinal inclination  $s$ .
- Take into consideration the longitudinal inclination  $s$ .
- When using a multi-layer plywood sheet (**63**) as the deck, bracing is not necessary.

## Diagonal planking

### Required components:

<b>38</b> Planking 20 x 4	1x
<b>39</b> Wood screw 6x80 SK-TX30 HPI	8x
<b>40</b> Height compensation	1x

### Assembly

1. Prepare planking 20 x 4 (**38**) for a force-locked connection.
2. Place planking 20 x 4 (**38**) diagonally between two console brackets on the deck and fix in place with Wood-Screw 6x80 SK-TX30 HPI (**39**).
3. Mount the height compensation (**40**).
4. Fasten Formwork Fixing-2 VGK (**5**) and Formwork Girder VGK (**6**), see Section "B5 Formwork unit" on page 66.
5. Fix the base spindles in place with 2x Wood-Screws 6x80 SK-TX30 HPI in each case (**39**).

(Fig. A8.01 + Fig. A8.01a)

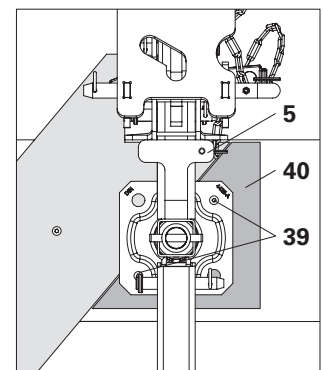

Fig. A8.01a

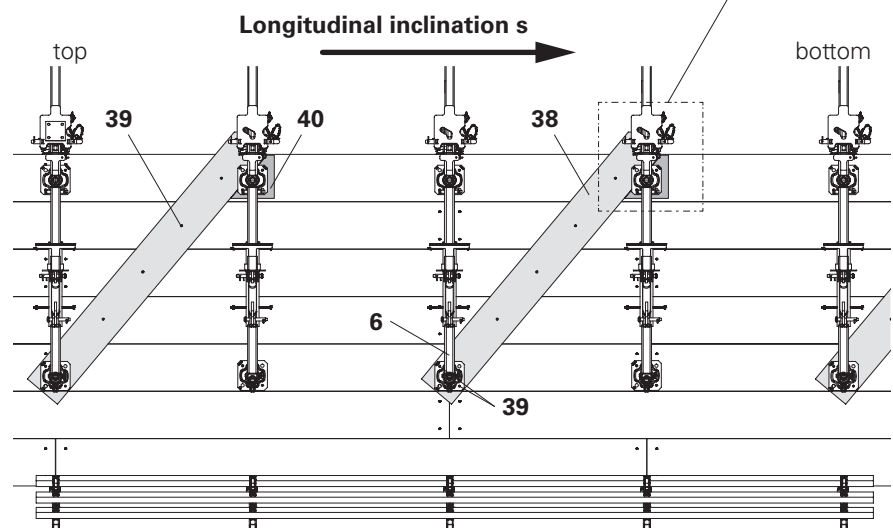

Fig. A8.01

# A8 Horizontal bracing at $3\% < s \leq 7\%$

## Scaffolding tube

### Required components:

<b>10</b> Bracing Connector VGK	2x
<b>11</b> Cutting Costs Scaffold Tube $\varnothing 48.3 \times 3.2$ mm	1x

### Assembly

1. Fit the Bracing Connector VGK (**10**) onto the Bracket Post VGK (**1a / 1b / 1c**) at the height of the deck with screw ISO 4014-M16x 080-8.8 (**10.1**) and Hex-Nut ISO 4032-M16-8 (**10.2**).
2. Mount the scaffolding tube (**11**) on two bracing connectors VGK (**10**).
3. Align console brackets and tighten Bracing Connectors VGK (**10**), AF 19. (Fig. A8.02 + Fig. A8.02a)

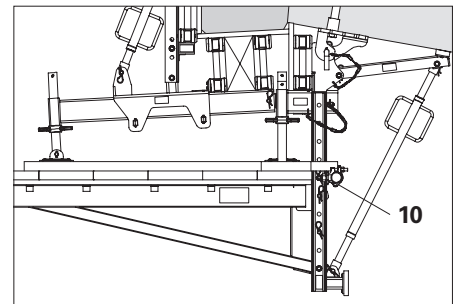

Fig. A8.02a

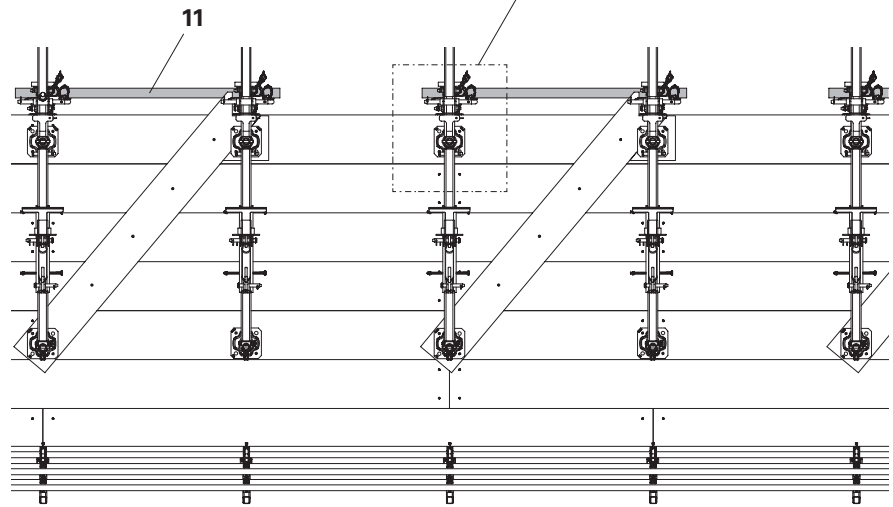

Fig. A8.02

## On the abutment



- For longitudinal inclination  $0\% < s \leq 3\%$ , diagonal bracing and horizontal bracing must be installed. (Fig. A8.03)
- For platform units in longitudinal inclination  $s > 3\%$  at the abutment, the bracing with scaffolding tubes must be verified specifically for each project.

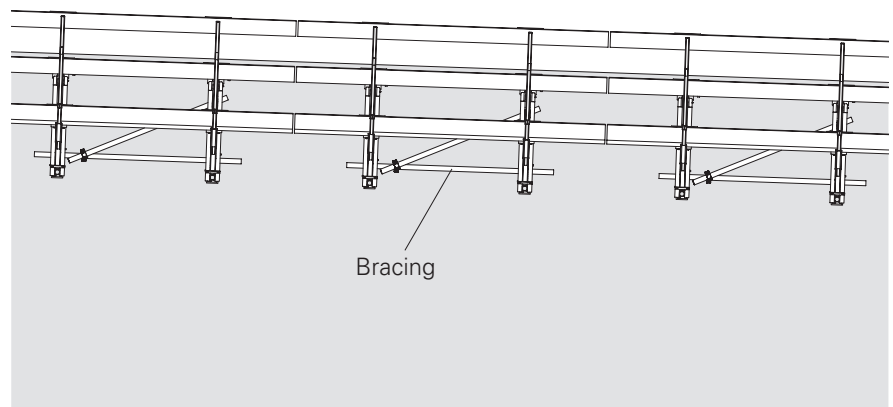

Fig. A8.03



- The horizontal bracing applies to VGK Concreting Platform, VGK 160 and VGK Flex.
- In general, at least one horizontal Cutting Costs Scaffold Tube Ø48.3x3.2 mm (**11**) must be mounted for crane offsets.
- The mounting position for the standard platforms is on the wall side. It is possible to mount Work Platform VGK Flex on both sides.
- For longitudinal slopes or planned horizontal loads, a diagonal must also be installed see Section "On the abutment" on page 47

## Components

- 10** Bracing Connector VGK
- 11** Cutting Costs Scaffold Tube Ø48.3x3.2 mm
- 65** Swivel Coupler SW Ø48/48 mm ga

## Assembly

1. Fit the Bracing Connector VGK (**10**) onto the Bracket Post VGK (**1a / 1b / 1c**) at the indicated positions with screw ISO 4014-M16x080-8.8 (**10.1**) and Hex-Nut ISO 4032-M16-8 (**10.2**).
  2. Attach scaffolding tube Ø48.3x3.2 mm (**11**) and tighten the bracing connectors.
- For diagonals:
3. Fit the Swivel Coupler SW48/48 mm ga (**65**) onto the Cutting Costs Scaffold Tube Ø48.3x3.2 mm (**11**).
  4. Attach Cutting Costs Scaffold Tube Ø48.3x3.2 mm (**11**) to Swivel Coupler SW Ø48/48 mm ga (**65**) and Bracing Connector VGK (**10**) and tighten.

(Fig. A9.01 – Fig. A9.01b)



When using the VGK 160 in conjunction with Bracket Post VGK 70, a horizontal scaffolding tube is not needed.

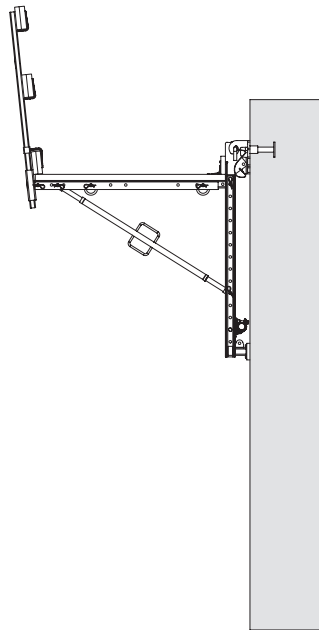

Fig. A9.01a

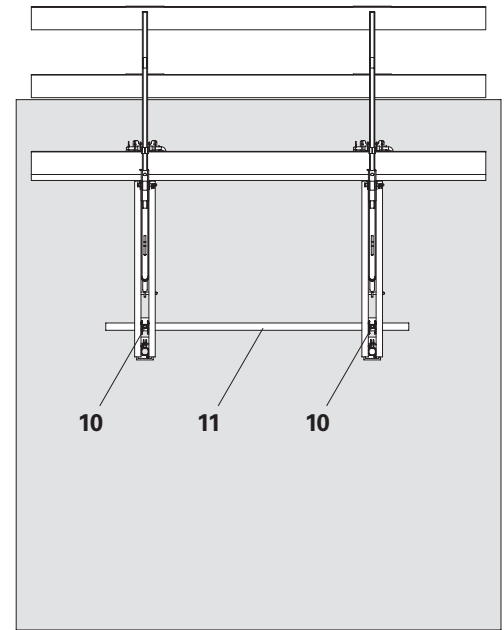

Fig. A9.01b

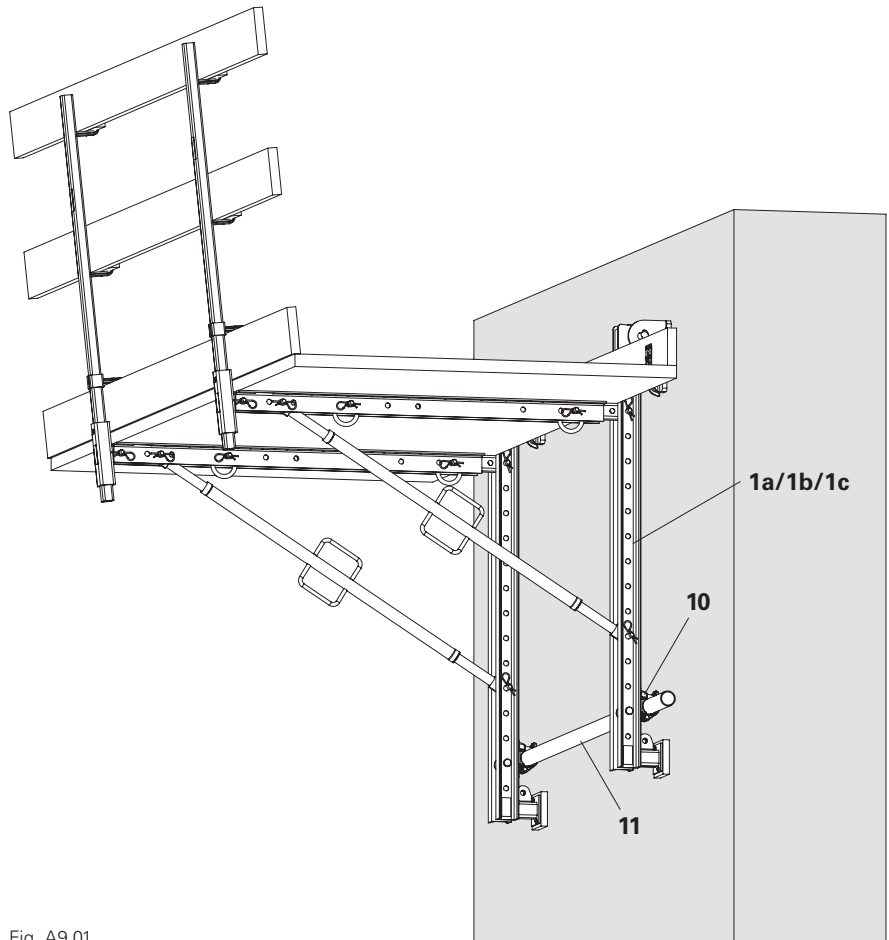

Fig. A9.01

# A10 Horizontal bracing for demolition work and strong vibrations



- If the cantilevered parapet bracket is used during demolition work or is subjected to strong vibrations, the Kicker Brace AV must also be secured against twisting at the pressure point.
- Do not use the light platform version for demolition work.

## Assembly

1. Fit a Swivel Coupling EN74 38/48 mm (**32**) to the spindle sleeve on each Kicker Brace AV (**2**).
  2. In each case, connect two console brackets to a Cutting Costs Scaffold Tube  $\text{Ø}48.3 \times 3.2$  mm (**11**).
- (Fig. A10.01)

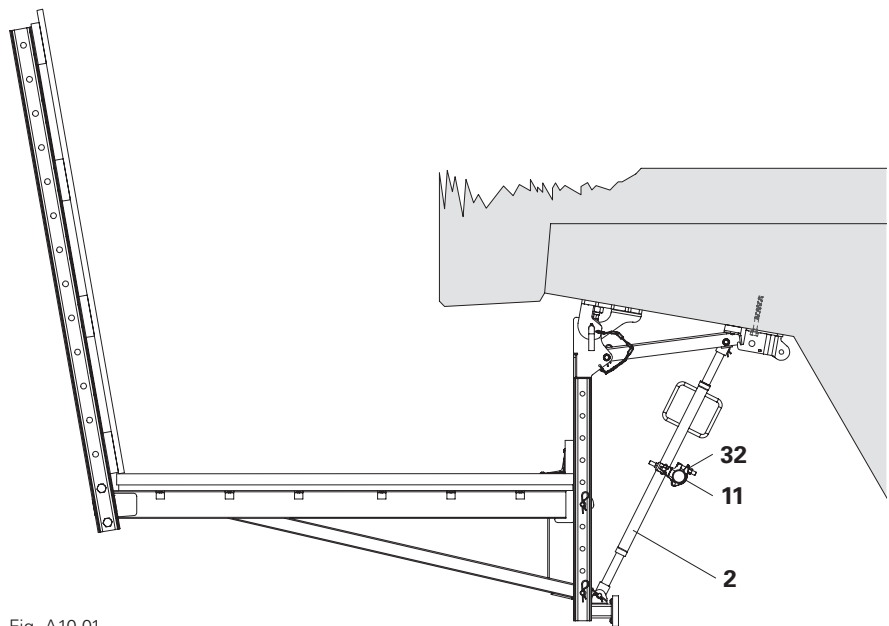

Fig. A10.01

The sliding capacity of the compression bearing on Bracket Cantilever VGK 50 (3) must be checked before each use.



Bracket cantilevers are not to be used if the grouting is damaged.

**The inspection includes a visual and functionality check**

**Purpose**

Operational and functional reliability can be guaranteed due to the inspection carried out before the initial commissioning, as well as regularly occurring inspections.

**Visual inspection**

- Wear and tear
- Cracks, grooves or similar in the grouting (3.3).

**Functional inspection**

- Formwork panel moveable – approx. 2 mm forwards, back and twistable. (Fig. A11.01 – Fig. A11.03)
- The formwork panel automatically goes back to the starting position.

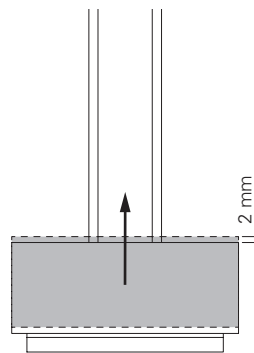
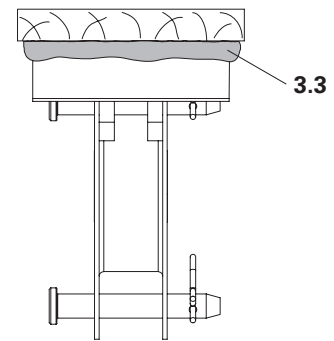
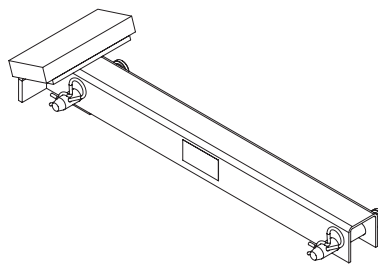

Fig. A11.01

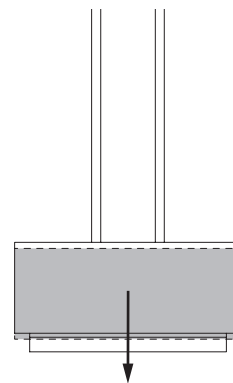

Fig. A11.02

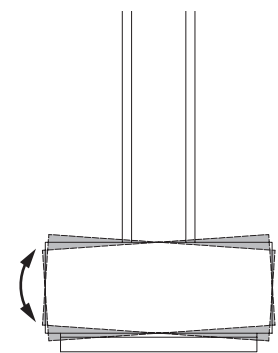

Fig. A11.03

**Measures**

If any defects are determined during the safety inspection, they must be eliminated according to the instructions provided by the qualified person. A new inspection must then be performed.



## Assembly on the cantilever



### Danger

Leading edges are present during assembly!

There is a risk of falling off the cantilevered parapet.

- ⇒ Assemble platform unit and platform unit from a safe and secure working area, e.g.:
- Telescopic work platform.
  - Temporary working scaffold.
  - Personal protective equipment to prevent falling from a height (PPE).



The formwork unit is assembled and adjusted from the platform unit. Depending on the stage of construction, temporary safety measures to prevent falling may be required.

### Removing the anchor positioning stud

1. Straighten wire nails.
  2. Retract the formwork. Pull the wire nails through the formwork panel.
  3. Unscrew Anchor Posit. Stud M24 ga (22) from the anchor sleeve by means of an Allen key AF 14.
- (Fig. B1.01)

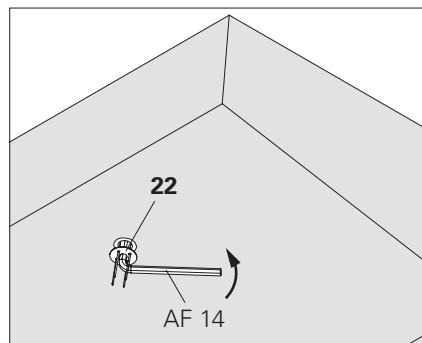

Fig. B1.01

### Removing threaded cone

1. Retract the formwork.
  2. Push back wire nail with a hammer.
  3. Unscrew Threaded Cone M24/40 mm (17) from the anchor sleeve using a ratchet wrench and socket AF 22.
- (Fig. B1.02)

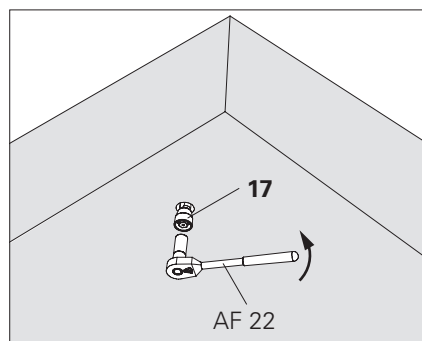

Fig. B1.02



## Assembly

1. Insert Screw ISO 4014-M24x100-8.8-ga (16) through Suspension Head VGK Flex (12a) on the slot side, and screw it onto Anchor Sleeve M24 (13) but do not tighten. (Fig. B1.03a)
2. Push Suspension Head VGK Flex (12a) into position and tighten Screw ISO 4014-M24x100-8.8-ga (16). (Fig. B1.03b)
- (Fig. B1.03)
3. Fix Bracket Cantilever VGK 50 (3) to Bracket Post VGK (3.1) using bolts and cotter pins (1). (Fig. B1.04)
4. Attach pre-adjusted Kicker Brace AV (2) to Bracket Cantilever VGK 50 (3) using bolts and cotter pins (3.2).
5. Attach pre-adjusted Kicker Brace AV (2) to the Bracket Post VGK (1) using bolts and cotter pins (2.2). (Fig. B1.05)
6. Attach Bracket Unit VGK (1) to Suspension Head VGK (12) and secure by means of locking pins Ø20x260 mm (1.1) and Cotter Pins 4/1 ga.
7. Vertically align Bracket Unit VGK (1) with Kicker Brace AV (2). (Fig. B1.06 + Fig. B1.07)

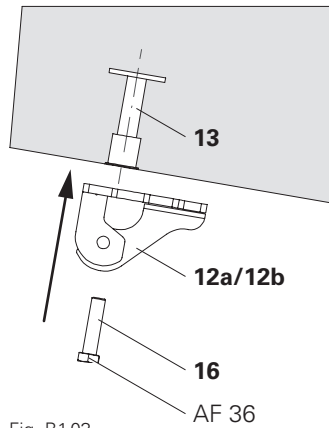

Fig. B1.03

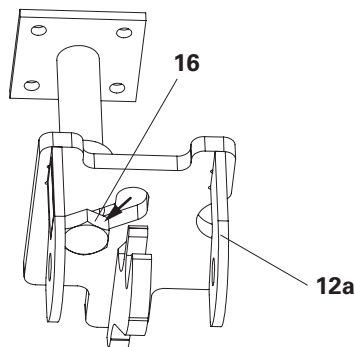

Fig. B1.03a

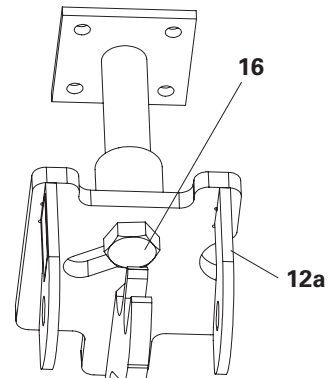

Fig. B1.03b

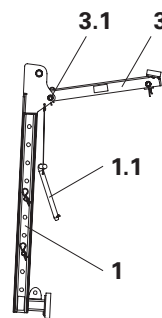

Fig. B1.04

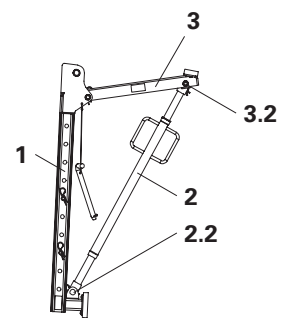

Fig. B1.05

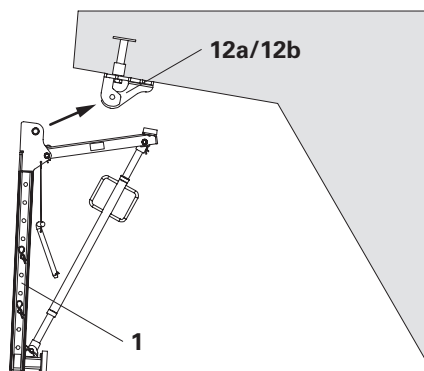

Fig. B1.06

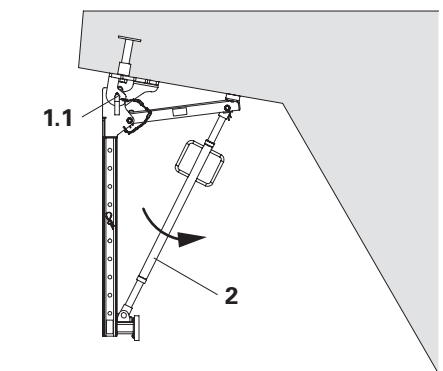

Fig. B1.07

## Assembly on the cantilever 35–75 cm – additional steps

1. Insert Adj. Base Plate UJB 38 mm-80/55 (9) into Bracket Unit VGK (1) and vertically align.
2. Secure the Adj. Base Plate UJB 38 mm-80/55 (9) against falling out and unintentional twisting, see Section “Intermediate area on cantilevers 35 – 75 cm” on page 14. (Fig. B1.08)

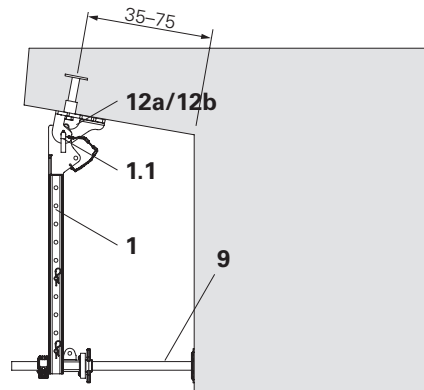

Fig. B1.08

## Assembly with Bracket Post VGK 70 – additional steps

Cantilever 35–75 or abutment:

1. Bolt Eye Nut RCS DW15 (59) into Bracket Post VGK (1) using Pins Ø16x90 mm coat (60) and secure with Cotter Pins 4/1 ga (61). (Fig. B1.09 + Fig. B1.09a)

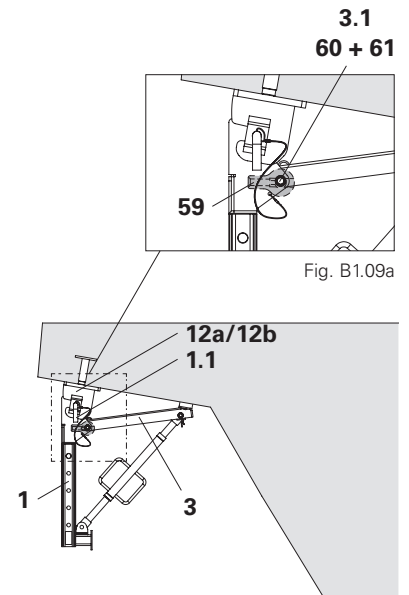

Fig. B1.09

Cantilever  $\geq$  75 cm:

1. Attach Eye Nut RCS DW15 (59) to Bracket Cantilever VGK 50 (3) and Bracket Post VGK (1) using bolts and cotter pins (3.1). (Fig. B1.09 + Fig. B1.09a)

## Assembly on the abutment



When used on the abutment with Suspension Head Flex VGK, a scaffolding tube bracing must always be mounted.

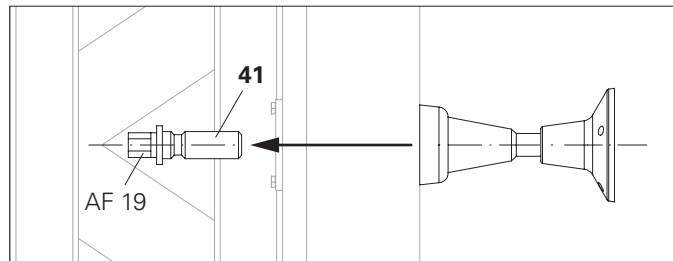

Fig. B1.10

### Removing the advancing screw

1. Loosen and remove Advancing Screw M24 (**41**) from the rear side of the formlining, AF 19.
2. Remove formwork. (Fig. B1.10)

### Assembly

1. Fasten Suspension Head VGK (**12**) to Screw-On Cone-2 M24/DW20 (**21**) with Screw ISO 4014-M24x070-10.9 (**23**). (Fig. B1.11)
2. Attach Bracket Post VGK (**1**) to Suspension Head VGK (**12**) and secure by means of locking pins  $\text{\O}20 \times 260$  mm (**1.1**) and Cotter Pins 4/1 ga.
3. Assemble the scaffolding tube bracing. (Fig. B1.12 + Fig. B1.13)

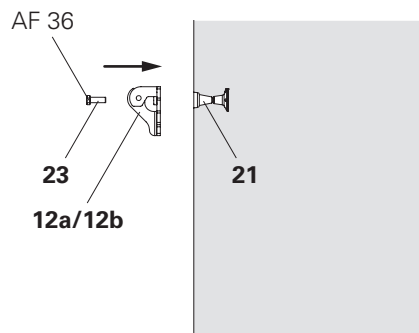

Fig. B1.11

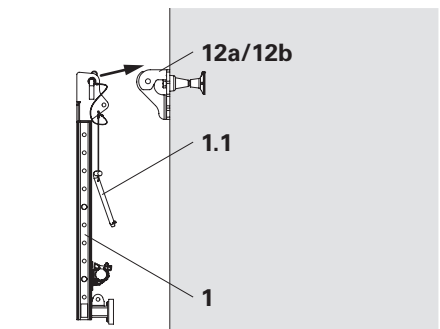

Fig. B1.12

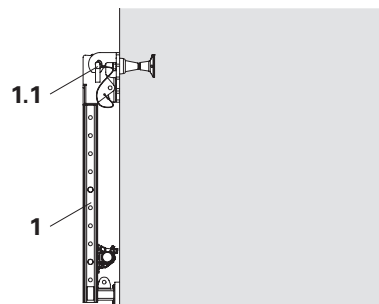

Fig. B1.13

## Assembly of Platform Cantilever Beam VGK

1. Position the upper Pin Ø16x90 mm coat (1.3) in the Bracket Post VGK at platform height.
2. Remove the lower Pin Ø16x90 mm coat (4.1).
3. Attach the platform beam (4) to the Pins Ø16x90 mm coat (1.3).
4. Secure with the lower Pin Ø16x90 mm coat (4.1). (Fig. B2.01)
5. Attach more platform beams.
6. Install planking, see Section A6.

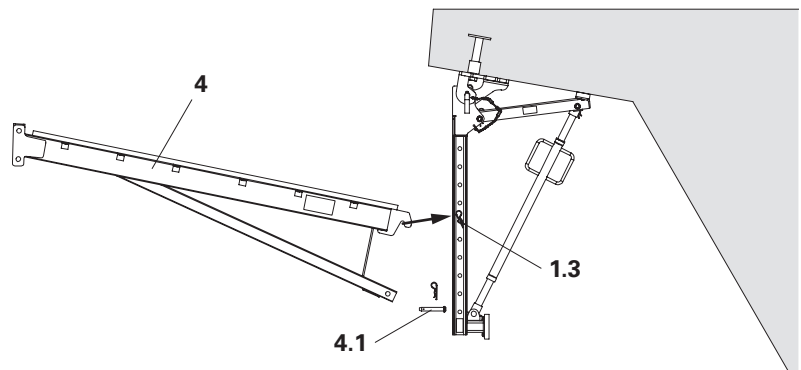

Fig. B2.01

## Assembly of lateral protection

1. Insert Guardrail Post -2 HSGP (29) into all Platform Cantil. Beams VGK 170 (4). (Fig. B2.02)
2. Insert and secure lateral protection barriers, see Section "A6 Decks and lateral protection" on page 42.



Alternatively, Lateral Protection Barriers PMB can be used instead of guardrails and toe boards. (Fig. B2.03)

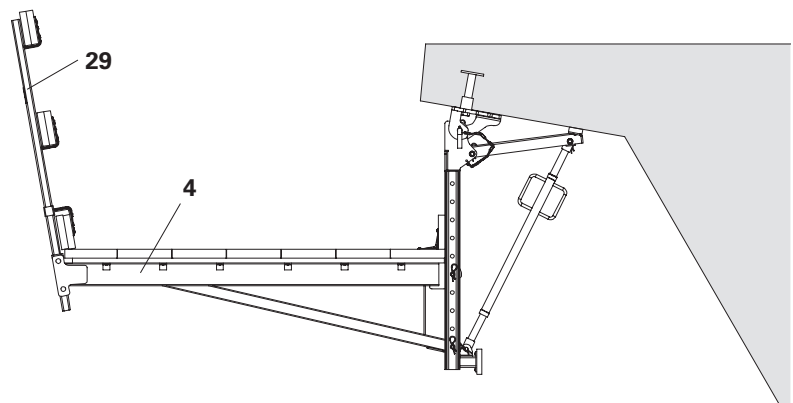

Fig. B2.02

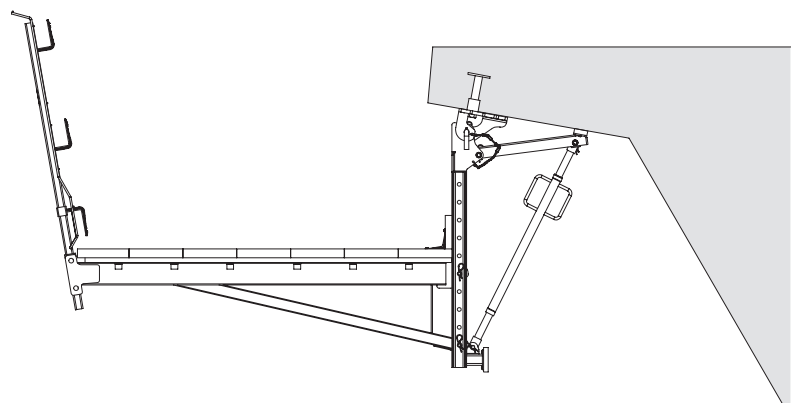

Fig. B2.03

## Preparing for assembly



- A flat assembly surface is required for installation.
- If required, secure intermediate posts with temporary supports to prevent tipping over.
- Aligned and calibrated stops simplify the process of pre-assembling the work platform in a quick and precise manner (Fig. B3.01).

## Fitting the assembly surface

1. Mount Suspension Head VGK Flex (**12a**) on the assembly surface at distance "c".
2. Mount sufficiently long squared timbers in the project-specific dimensions on the assembly surface. (Fig. B3.01 + Fig. B3.01a)

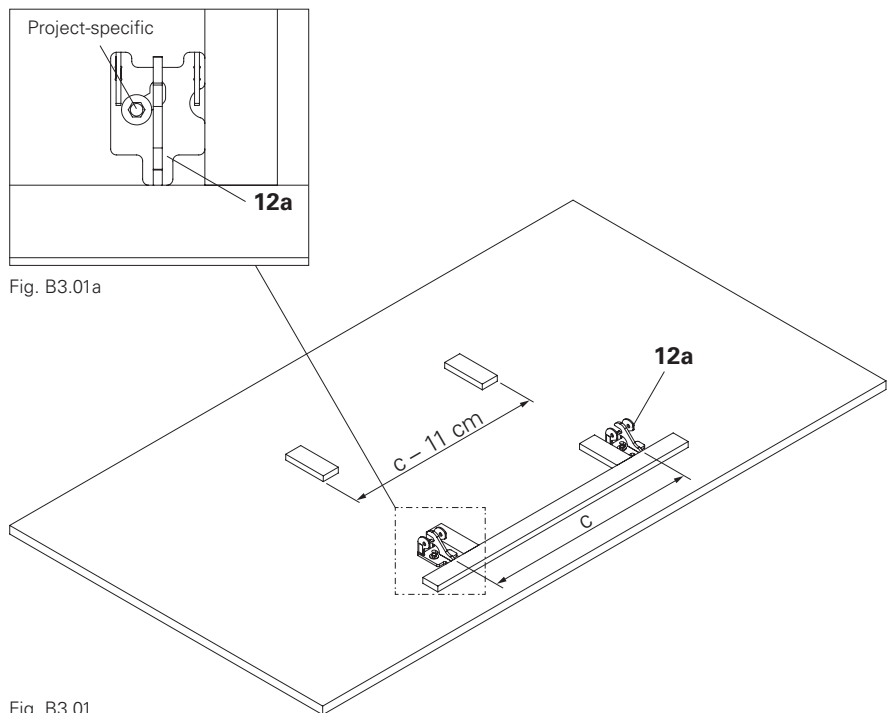

Fig. B3.01

## Mounting Platform VGK 160

### Assembly

1. Fit Bracket Post VGK (**1a/1b/1c**) onto Suspension Head VGK Flex (**12a**) with locking pin  $\varnothing 20 \times 260$  mm (**1.1**), align and secure with Cotter Pin 4/1 ga (**1.2**). (Fig. B3.02 + Fig. B3.02a)



PERI recommends fitting a scaffolding tube 48.3x3.2 mm (**11**) with Bracing Connectors VGK (**10**) onto the Bracket Posts VGK (**1a/1b/1c**) to brace the platforms.

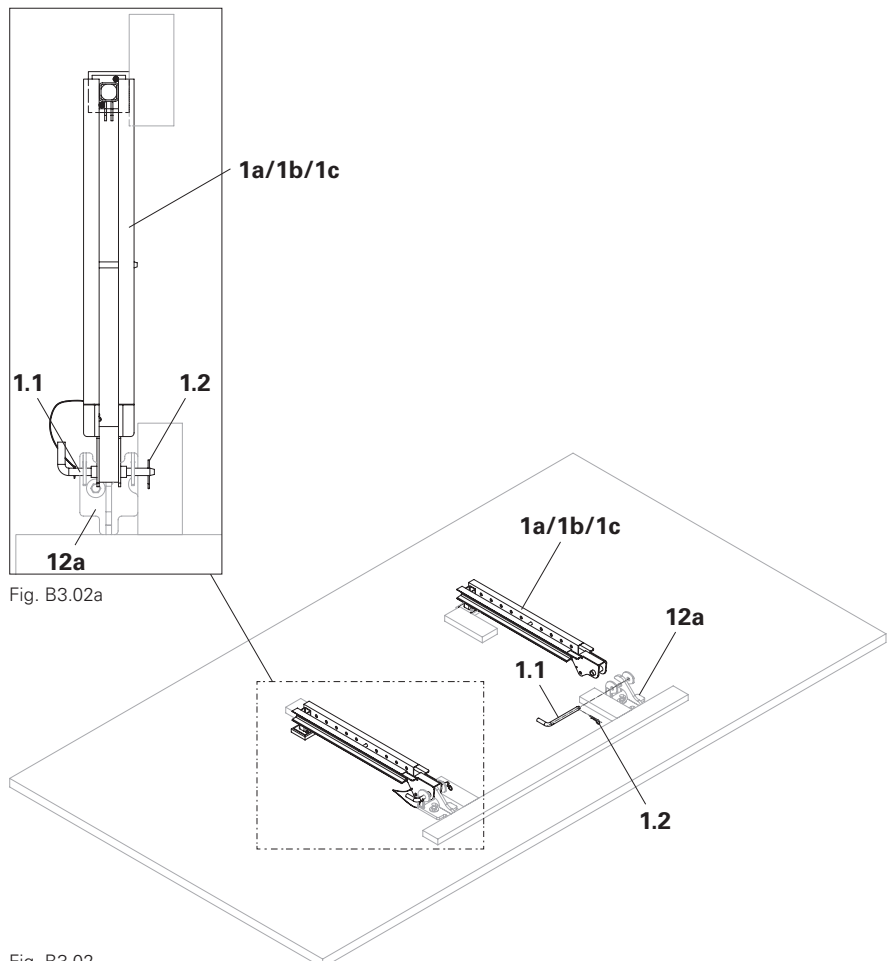

Fig. B3.02

## B3 Pre-assembling complete platform unit

2. Fit Bracing Connector VGK (**10**) onto Bracket Post VGK (**1a/1b/1c**) with Pin Ø16x90 mm coat (**10.1**) and secure with Cotter Pin 4/1 ga (**10.2**).
3. Fit the scaffolding tube Ø48.3x3.2 mm (**11**) onto the Bracing Connectors VGK (**10**).  
(Fig. B3.03)

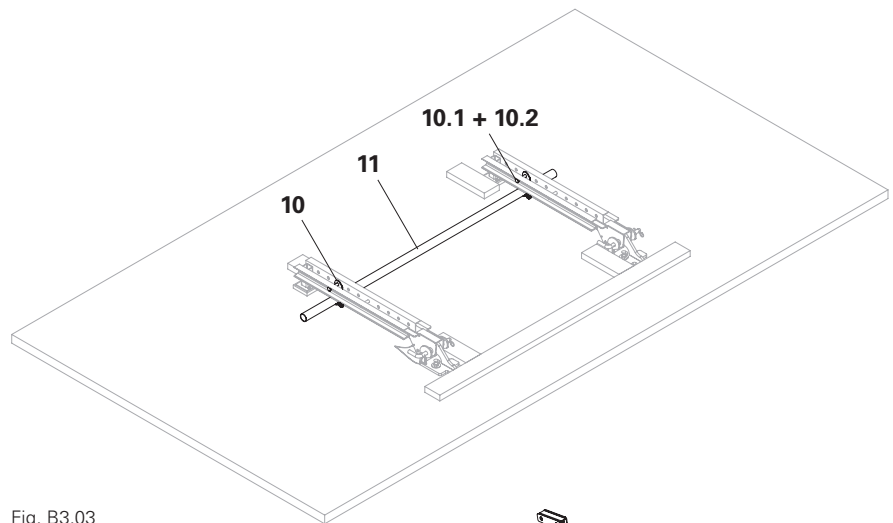

Fig. B3.03

3. Fit Platform Cantil. Beam VGK (**4**) onto Bracket Post VGK (**1a/1b/1c**) with Pin Ø16x90 mm coat (**1.3**) and Pin Ø16x90 mm coat (**4.1**) and secure with Cotter Pin 4/1 ga (**1.2 / 4.2**).  
(Fig. B3.04)

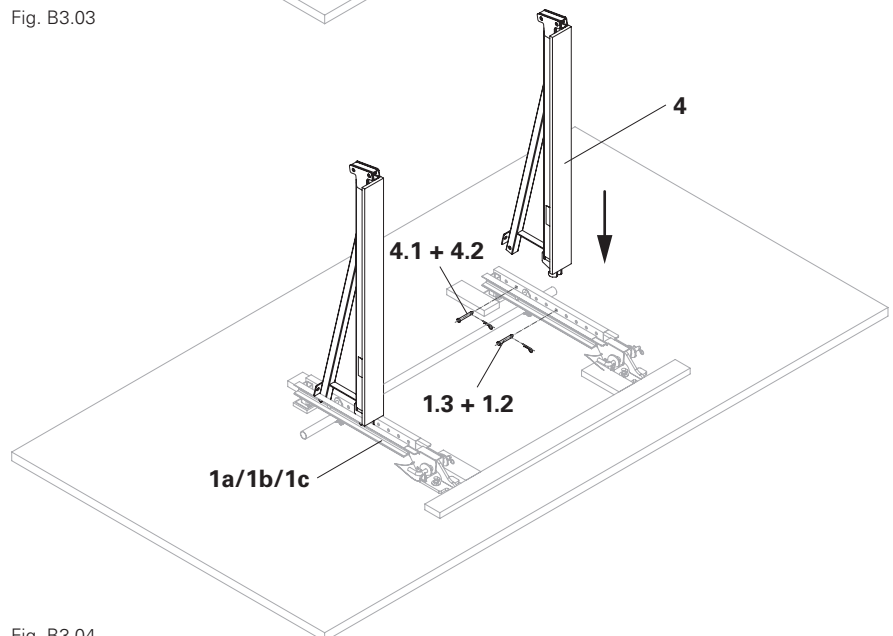

Fig. B3.04

4. Saw the multi-layer plywood sheet (**63**) to the specified dimensions.
5. Fit a multi-layer plywood sheet (**63**) onto Platform Cantil. Beam VGK (**4**) with Wood-Screws 6x80 SK-TX30 HPI (**39**).  
(Fig. B3.05)

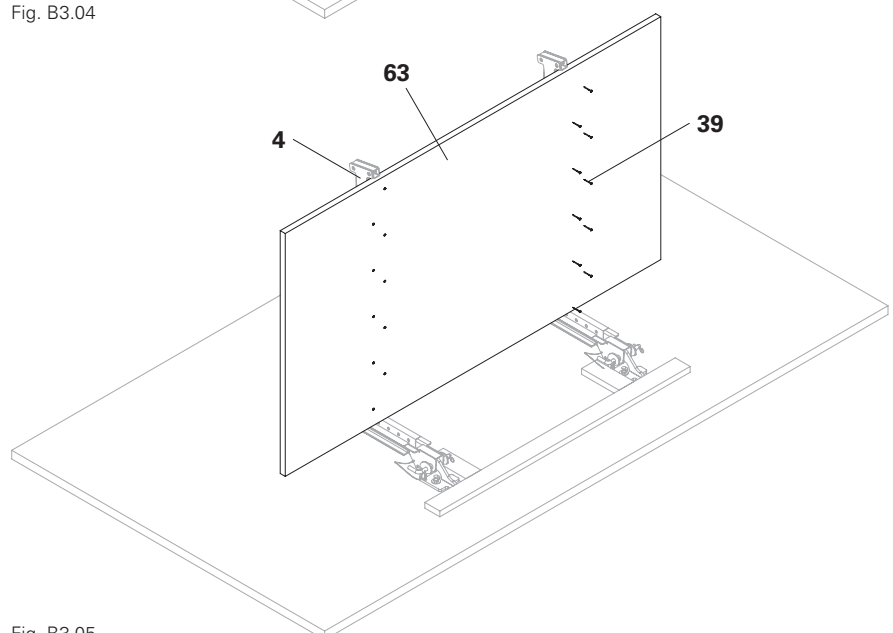

Fig. B3.05

## B3 Pre-assembling complete platform unit

6. Insert Guardrail Posts -2 HSGP (**29**) into the Platform Cantil. Beams VGK (**4**).

(Fig. B3.06)

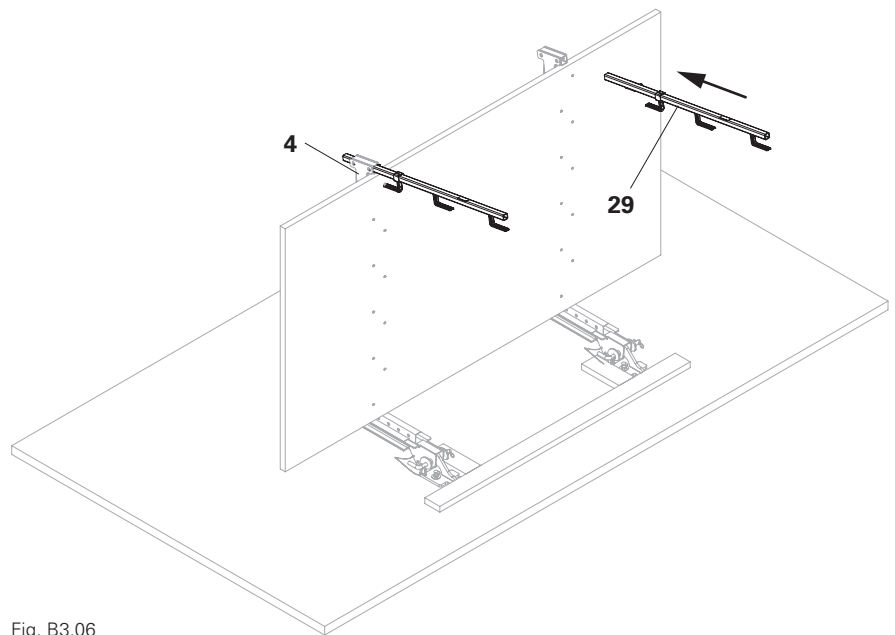

Fig. B3.06

7. Attach guardrail boards (**33**) to Guardrail Posts-2 HSGP (**29**) and fix them in place with wire pins or wood screws (**36**).
  8. Fasten the toe board (**34**) to the multi-layer plywood sheet (**63**) with angle brackets 90x90x65 mm (**64**) and wire pins or wood screws (**36**).
- (Fig. B3.07)
9. Remove the platform unit from the Suspension Head VGK Flex (**12a**).



Alternatively, Lateral Protection Barriers PMB can be used instead of guardrails and toe boards.

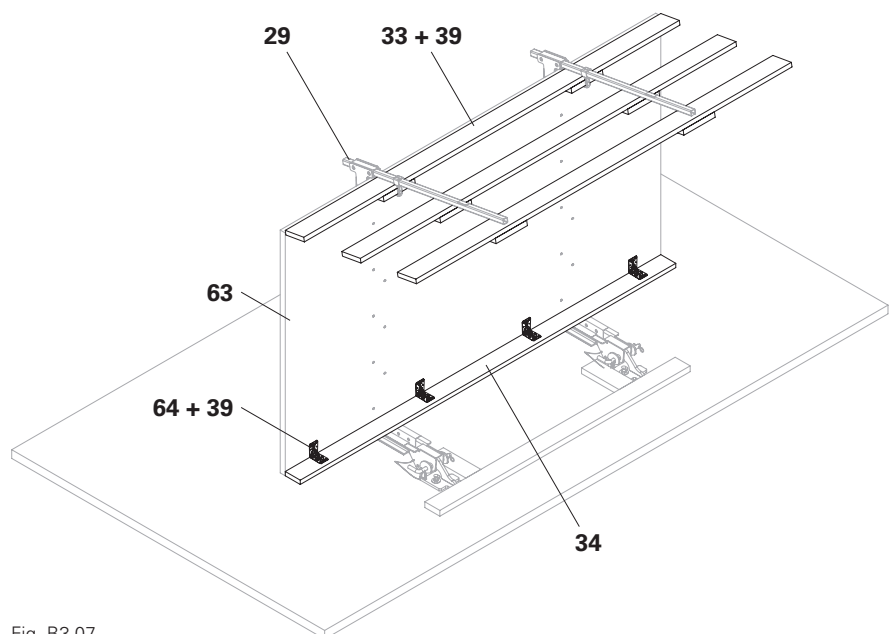
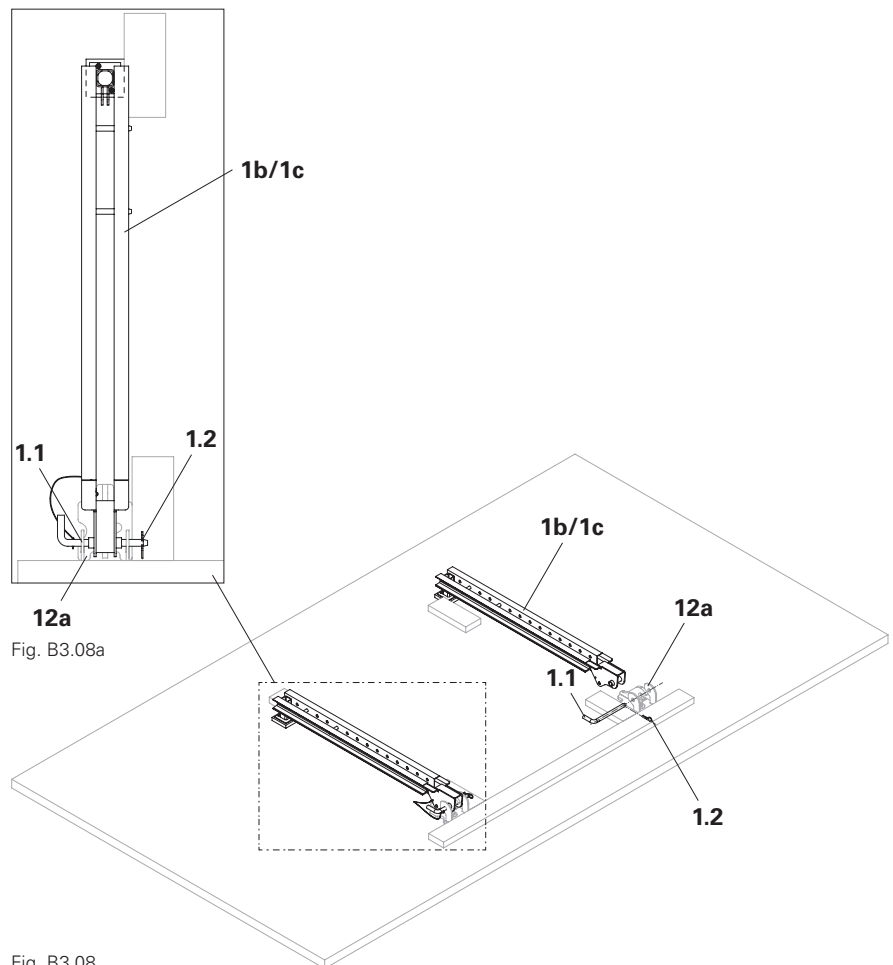

Fig. B3.07

## Installing Platform VGK Flex

### Assembly

1. Fit Bracket Post VGK (**1b/1c**) onto Suspension Head VGK Flex (**12a**) with locking pin  $\text{Ø}20 \times 260$  mm (**1.1**), align and secure with Cotter Pin 4/1 ga (**1.2**).  
(Fig. B3.02 + Fig. B3.02a)



2. Fit Bracing Connector VGK (**10**) onto Bracket Post VGK (**1b/1c**) with Pin  $\text{Ø}16 \times 90$  mm coat (**10.1**) and secure with Cotter Pin 4/1 ga (**10.2**).
3. Fit the scaffolding tube  $\text{Ø}48.3 \times 3.2$  mm (**11**) onto the Bracing Connectors VGK (**10**).  
(Fig. B3.09)

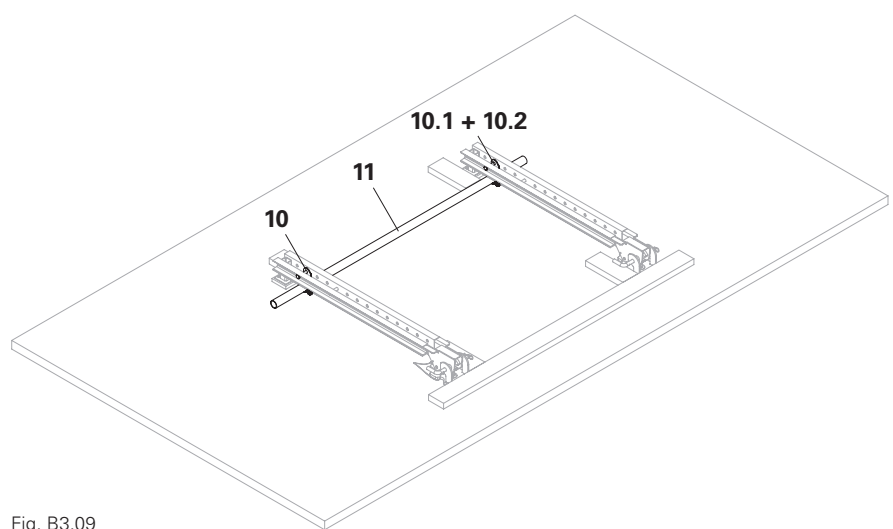



## B3 Pre-assembling complete platform unit

4. Fit Formwork Post VGK (**7/8**) onto Bracket Post VGK (**1b/1c**) with Pin Ø16x90 mm coat (**7.2a**) and secure with Cotter Pin 4/1 ga (**7.2a**).
  5. Fit Kicker Brace AV (**2**) onto Bracket Post VGK (**1b/1c**) with Pin Ø16x90 mm coat (**1.3**) and Cotter Pin 4/1 ga (**1.2**).
  6. Fit Kicker Brace AV (**2**) onto Formwork Post VGK (**7/8**) with Pin Ø16x90 mm coat (**7.1b**) and Cotter Pin 4/1 ga (**7.2b**).
- (Fig. B3.10)

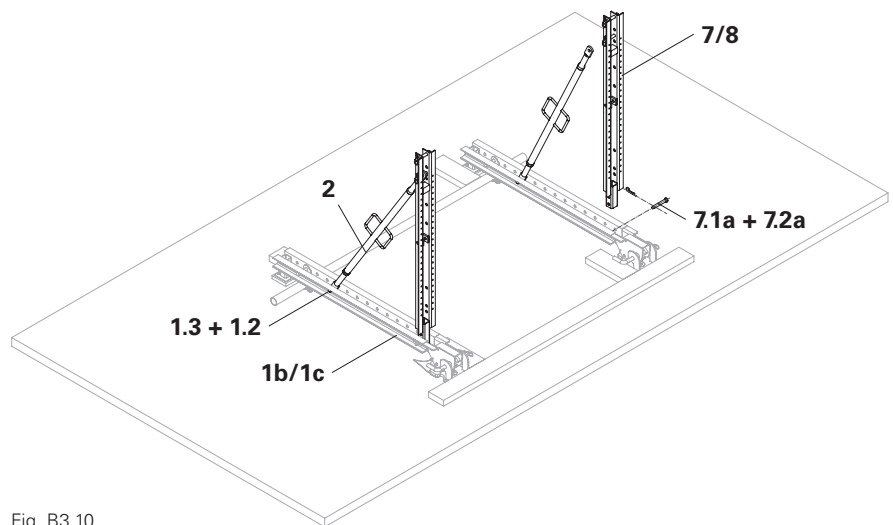

Fig. B3.10

7. Remove Pin Ø16x90 mm coat (**7.1b**) and Cotter Pin 4/1 ga (**7.2b**) from the Kicker Brace AV (**2**).
  8. Insert Guardrail Holder VGK (**62**) into Formwork Post VGK (**7/8**).
  9. Fit Guardrail Holder VGK (**62**) at the rear with Pin Ø16x90 mm coat (**7.1a**) and Cotter Pin 4/1 ga (**7.2a**).
  10. Fit Guardrail Holder VGK (**62**) and Kicker Brace AV (**2**) at the front with Pin Ø16x90 mm coat (**7.1b**) and Cotter Pin 4/1 ga (**7.2b**).
  11. Insert Guardrail Posts -2 HSGP (**29**) into the Guardrail Holders VGK (**62**).
- (Fig. B3.11)

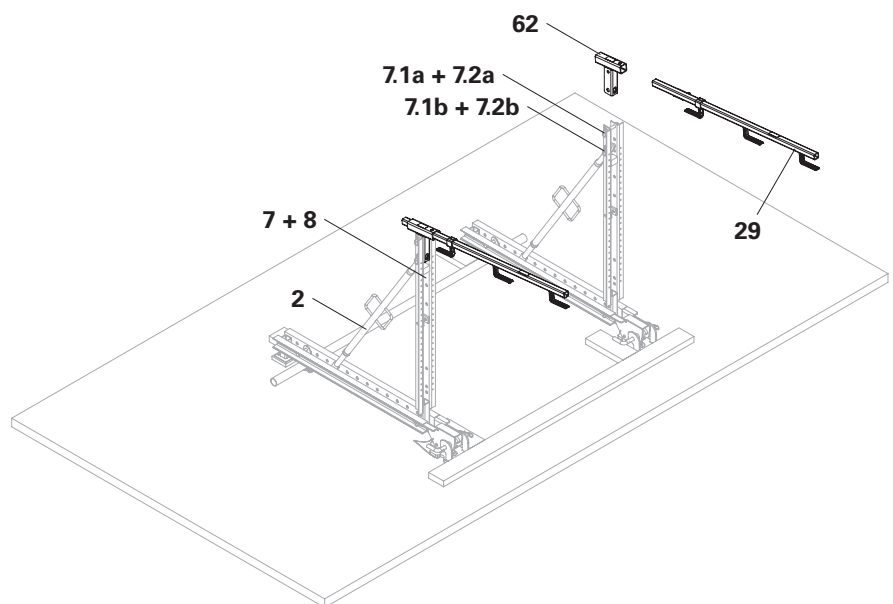

Fig. B3.11



If Suspension Links A13 (**75**) need to be fitted, see Section "With suspension link A13" on page 65.

12. Saw the multi-layer plywood sheet (**63**) to the specified dimensions.
  13. Fit a multi-layer plywood sheet (**63**) onto Formwork Post VGK (**7/8**) with Wood-Screw 6x80 SK-TX30 HPI (**39**).
- (Fig. B3.12)

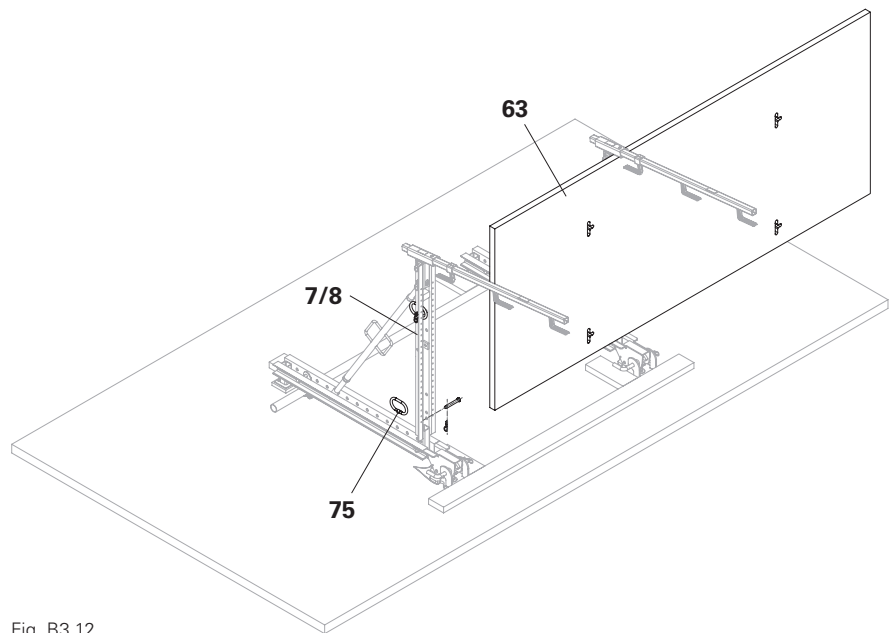

Fig. B3.12

14. Attach guardrail boards (**33**) to Guardrail Posts-2 HSGP (**29**) and fix them in place with wire pins or wood screws (**36**).
  15. Fasten the toe board (**34**) to the multi-layer plywood sheet (**63**) with angle brackets 90x90x65 mm (**64**) and wire pins or wood screws (**36**).
- (Fig. B3.13)
16. Remove the platform unit from the Suspension Head VGK Flex (**12a**).



Alternatively, Lateral Protection Barriers PMB can be used instead of guardrails and toe boards.

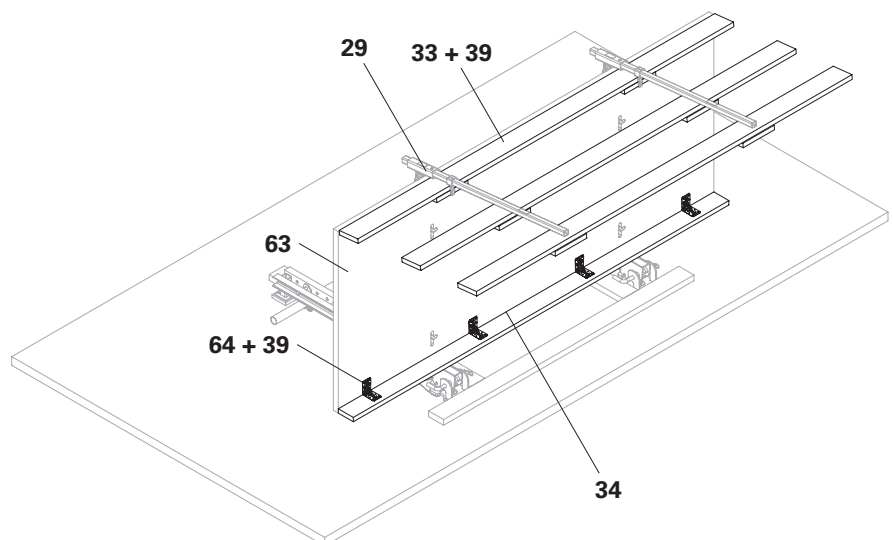

Fig. B3.13

# B4 Attaching complete platform unit

## With transportation fork



- Guide the work platform with ropes when attaching it.
- Do not stand under the suspended load.
- Fit the locking pin  $\text{Ø}20 \times 260$  mm (1.1) from a safe workplace.

### Attaching

1. Pick up platform unit with suitable fork (70).
2. Attach the platform unit to the Suspension Shoes VGK Flex (12a).
3. Fix the platform unit to Suspension Shoes VGK Flex (12a) with locking pin  $\text{Ø}20 \times 260$  mm (1.1) and secure with Cotter Pin 4/1 ga (1.2). (Fig. B4.01 – Fig. B4.01b)

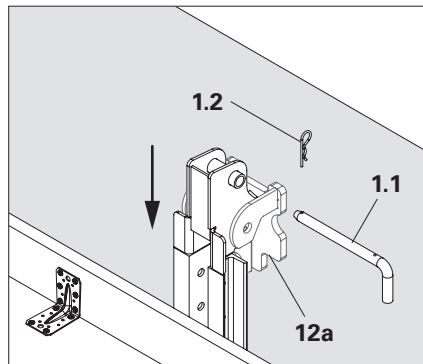

Fig. B4.01a

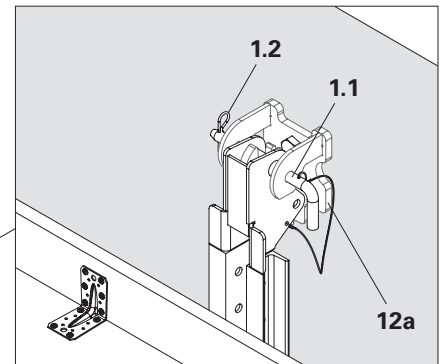

Fig. B4.01b

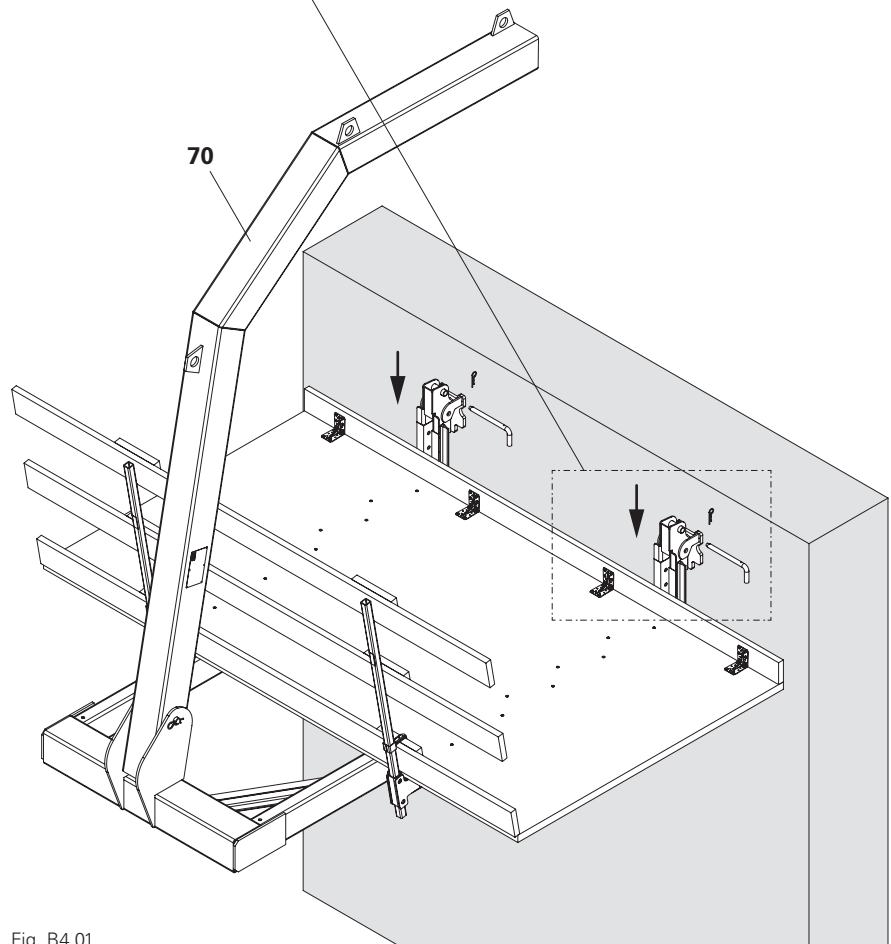

Fig. B4.01

## With round slings



- Use round slings with sufficient load-bearing capacity.
- Guide the work platform with ropes when attaching it.
- Do not stand under the suspended load.
- Mount toe boards (34) only after the suspension process.
- Fit the locking pin  $\varnothing 20 \times 260$  mm (1.1) from a safe workplace.

### Attaching VGK 160

1. Attach round slings (71) to the front and rear at the specified points on Platform Cantilever Beam VGK (4).
  2. Attach round slings (71) to the crane with four-strand hanger (72) and lift platform unit.
  3. Attach the platform unit to the Suspension Shoes VGK Flex (12a).
  4. Fix the platform unit to Suspension Shoes VGK Flex (12a) with locking pin  $\varnothing 20 \times 260$  mm (1.1) and secure with Cotter Pin 4/1 ga (1.2).
- (Fig. B4.02 + Fig. B4.02a + Fig. B4.01b)

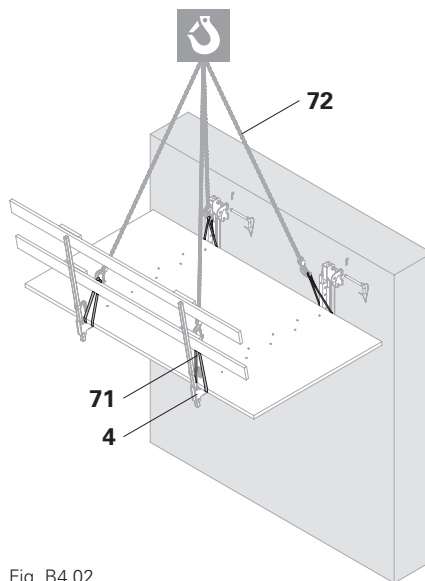

Fig. B4.02

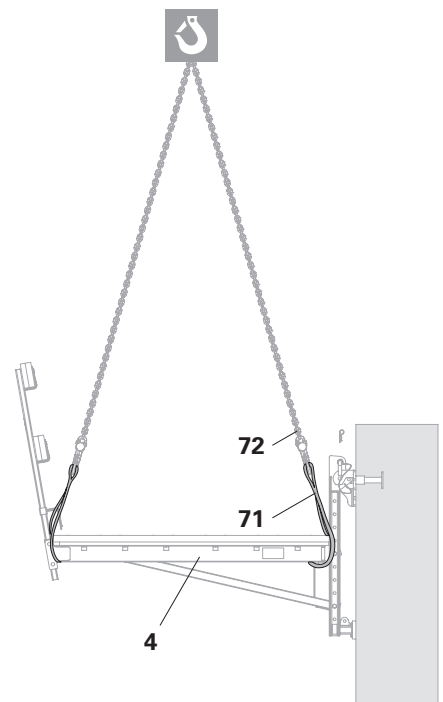

Fig. B4.02a

### Attaching VGK Flex

1. Attach round slings (71) to the front and rear at the specified points on Formwork Post VGK (7/8).
  2. Attach round slings (71) to the crane with four-strand hanger (72) and lift platform unit.
  3. Attach the platform unit to the Suspension Shoes VGK Flex (12a).
  4. Fix the platform unit to Suspension Shoes VGK Flex (12a) with locking pin  $\varnothing 20 \times 260$  mm (1.1) and secure with Cotter Pin 4/1 ga (1.2).
- (Fig. B4.03 + Fig. B4.03a + Fig. B4.01b)

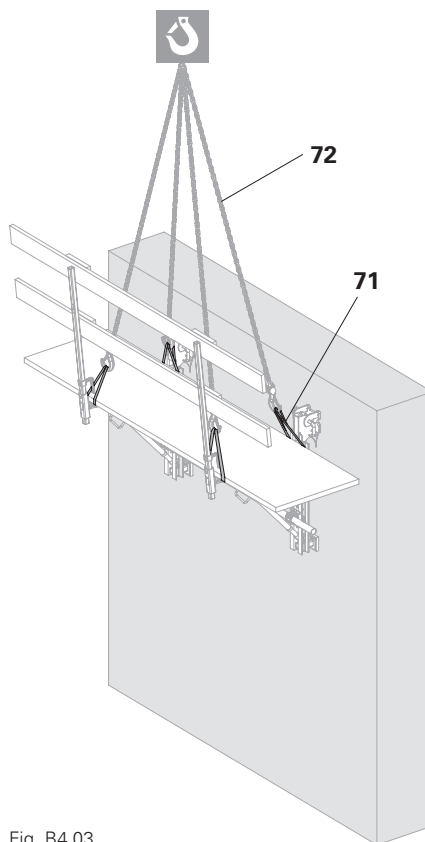

Fig. B4.03

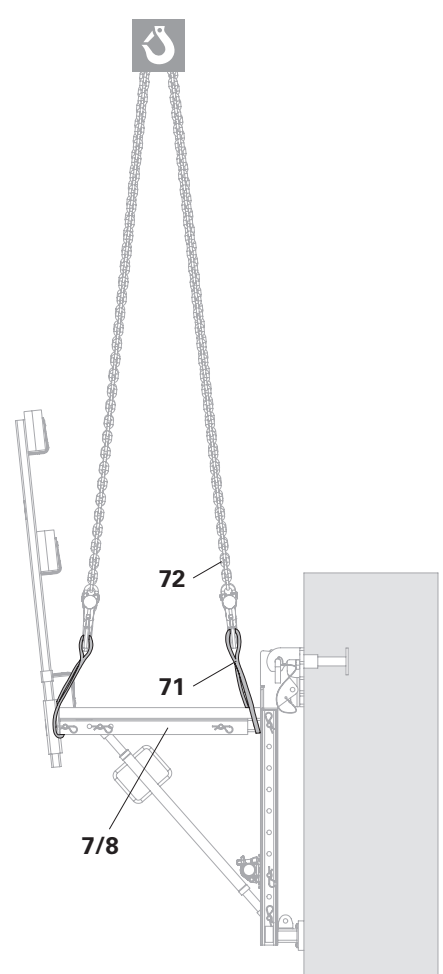

Fig. B4.03a

## With suspension link A13



- Platform Units VGK Flex with Formwork Post VGK 120 can be moved on a Suspension Link A13.
- The Lifting Gear 4 skeins has a chain length of 2.0 to 4.0 m.

### Assembling Suspension Link A13

- Cut four 10 x 2 cm slots at the indicated intervals. (Fig. B4.04).
- Guide Suspension Link A13 (75) into the opening, fit with Pin  $\text{\O}16 \times 90$  mm coat (60) and secure with Cotter Pin 4/1 ga (61).
- Fit the screw into the deck to prevent the Suspension Link A13 (75) from falling through to the bolt. (Fig. B4.05 + Fig. B4.06)



Narrow platform/wide platform

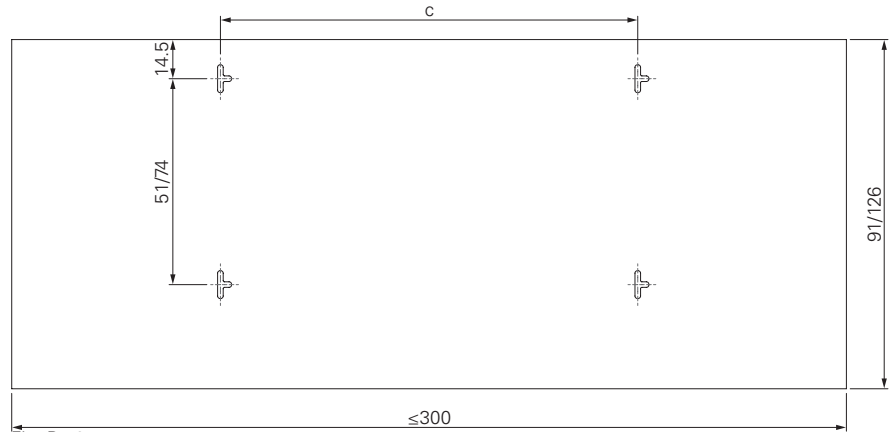

Fig. B4.04



- Choose a chain sling length that ensures that the solid angle of the chain inclination against the vertical is not more than  $40^\circ$ . (Fig. B4.05 + Fig. B4.06)
- Asymmetrical platforms can also be moved, but the centre of gravity must be in the middle third of c.
- Separate verification must be provided in the event of deviations.

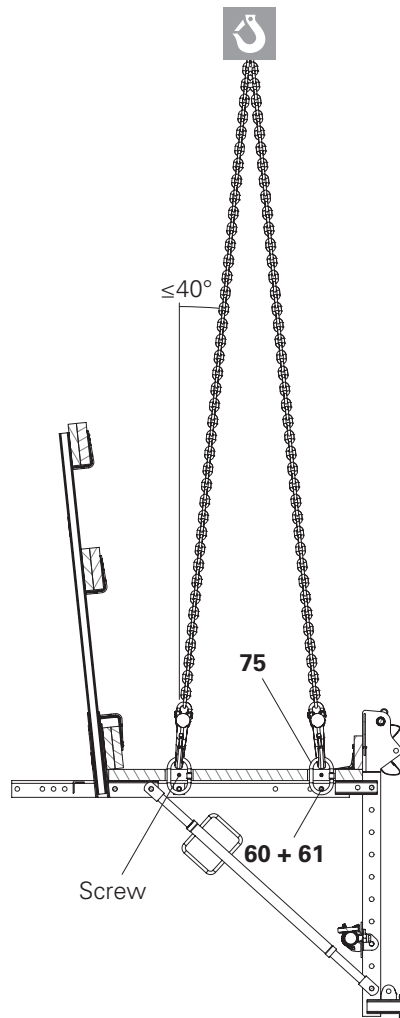

Fig. B4.05

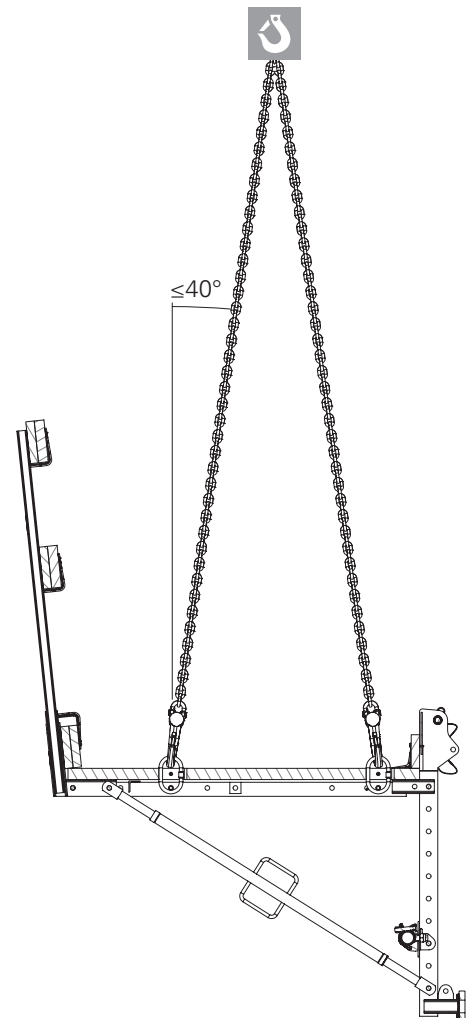

Fig. B4.06

## Assembly with the Formwork Support VGK 60

### ! Note

Higher concrete pressure on Formwork Support VGK 60 if the cantilevered parapet is higher than 50 cm!  
This can lead to deformation of Formwork Support VGK 60.

⇒ Centre Kicker Braces AV 82 and, if necessary, secure them against shifting, e.g. using shims or squared timbers. (Fig. B5.02a)



- The lateral formwork can only be fixed in place on Formwork Post VGK 70 with wood screws.
- This version is only possible at the abutment with Suspension Head VGK (12b).

### Assembly of Formwork Support VGK

1. Screw Tie Rod DW15 (56) into Eye Nut RCS DW15 (59)
2. Screw Hex-Nut DW15 SW30 50 mm (57) into Tie Rod DW15 (56) and adjust to match the required dimension beforehand.
3. Insert Hex-Nut DW15 SW30 50 mm (57) into Formwork Support VGK 60 (77) and screw in until contact is made with the front plate (77.2).
4. Fasten Formwork Support VGK 60 (77) to the planking (35) with wood screws. (Fig. B5.01a – Fig. B5.01c)

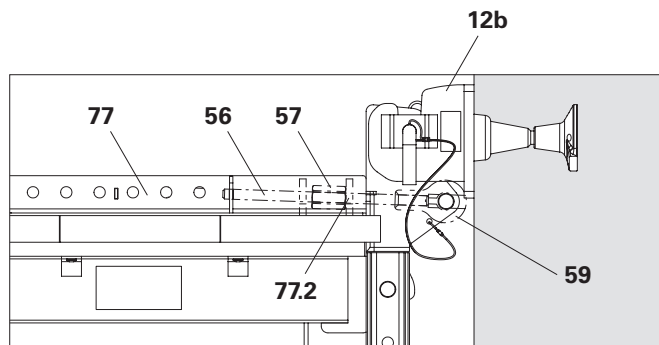

Fig. B5.01c

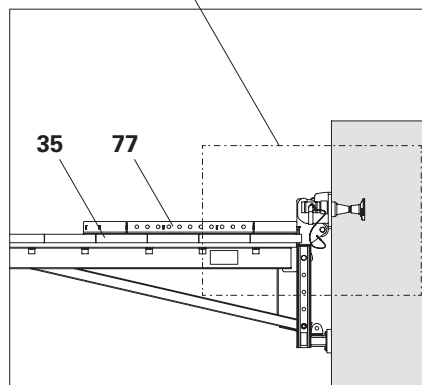

Fig. B5.01a

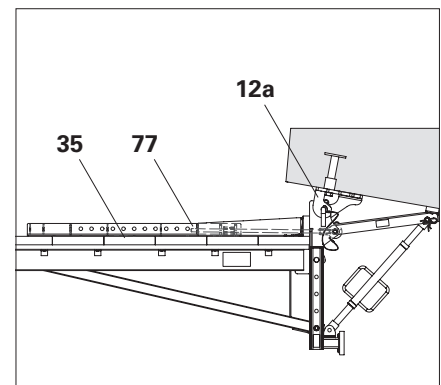

Fig. B5.01b

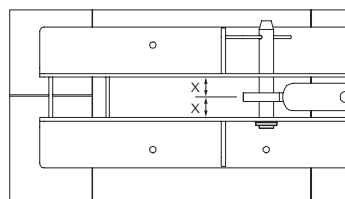

Fig. B5.02a

### Assembly of Formwork Post VGK for side formwork

1. Fasten Formwork Post VGK 70 (7) to Formwork Support VGK 60 (77) with bolts
2. Fix Kicker Brace AV 82 (2a) to the rearmost hole in Formwork Support VGK 60 (77) and to the top hole in Formwork Post VGK 70 (7) with bolts in each case.
3. Insert beam support (7.1) in the corresponding position. (Fig. B5.02)

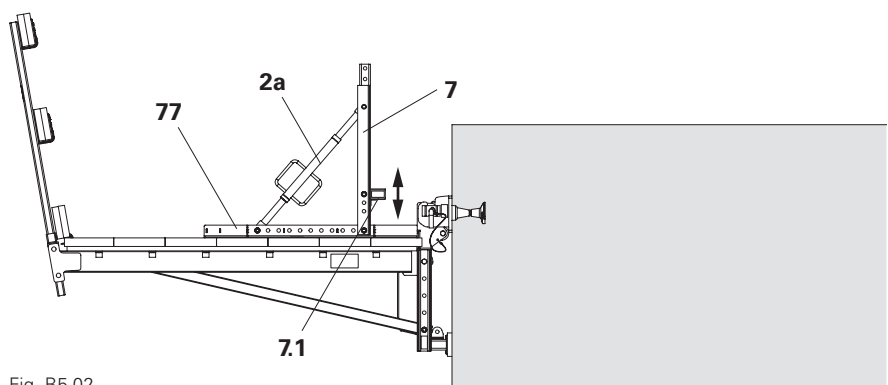

Fig. B5.02

## Formwork assembly

1. Position the slab formwork at the required height by means of squared timbers and wedges.  
→ The formwork panel (58) must rest on the beam support (7.1) with  $x < 30$  cm.
2. Place the side formwork on the beam support (7.1) and slab formwork, and fix to Formwork Post VGK 70 (7) with wood screws (36). (Fig. B5.03)

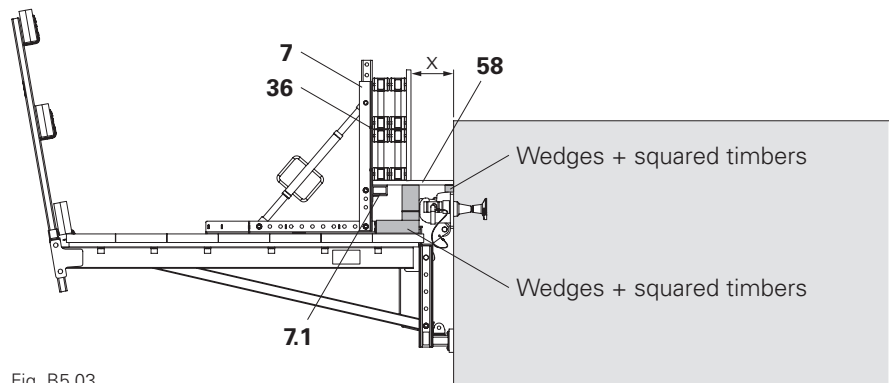

Fig. B5.03

## Assembly with the Formwork Support VGK 100

### Assembly of Formwork Fixing VGK

1. Release wedge (5.1).
2. Insert Formwork Fixing-2 VGK (5) into Bracket Post VGK (1).
3. Adjust Formwork Fixing-2 VGK (5) to the required height with the spindle.
4. Secure Formwork Fixing-2 VGK (5) with a wedge (5.1).
5. Position internal formwork (54) on Formwork Fixing-2 VGK (5) and align it. (Fig. B5.04)

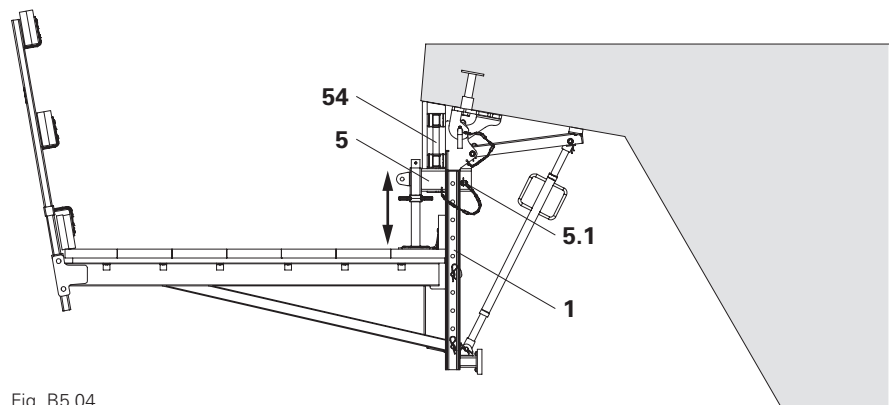

Fig. B5.04

### Assembly of Formwork Support VGK

1. Fix Formwork Support VGK (6) to Formwork Fixing-2 VGK (5) with bolts (6.4).
2. Bring the guide carriage (6.1) into position.
3. Fasten the bottom formwork to the guide carriage (6.1) with 2x Wood-Screws 6x60 SK-TX30 HPI (55).
4. Align slab formwork with pivoting base spindle (6.3) and guide carriage (6.1).
5. Fix both wedges (6.2) on the guide carriage (6.1) using a sledge hammer (5 kg). (Fig. B5.05 + Fig. B5.05a)

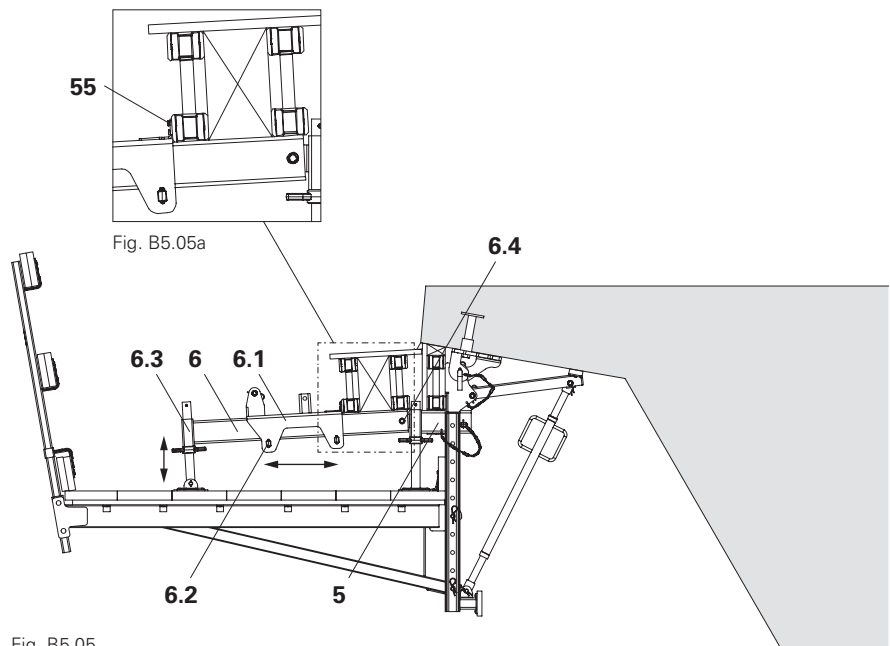

Fig. B5.05

## Assembly of Formwork Post VGK for side formwork

1. Attach Formwork Post VGK 70 (**7**) to the guide carriage (**6.1**) by means of bolts.
2. Fix Kicker AV 82 (**2a**) to the guide carriage (**6.1**) and Formwork Post VGK 70 (**7**) with bolts.
3. Insert beam support (**7.1**) in the corresponding position. (Fig. B5.06 + Fig. B5.06a)

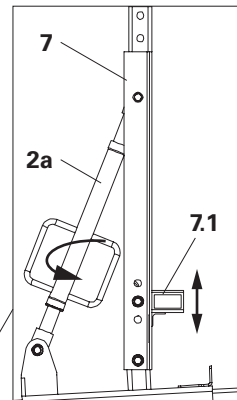

Fig. B5.06a

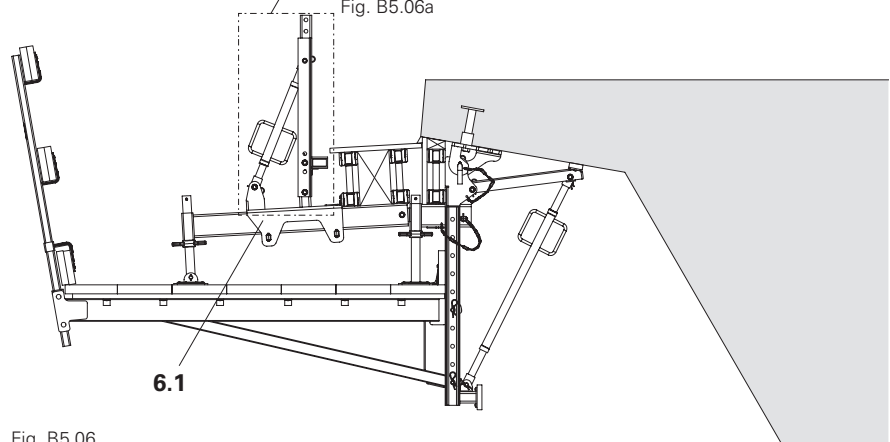

Fig. B5.06

## Assembly of side formwork

1. Place the side formwork on the beam support (**7.1**) and slab formwork, and fix to Formwork Post VGK 70 (**7**) with wood screws.
2. Align Formwork Post VGK 70 (**7**) with Kicker AV 82 (**2a**). (Fig. B5.07)

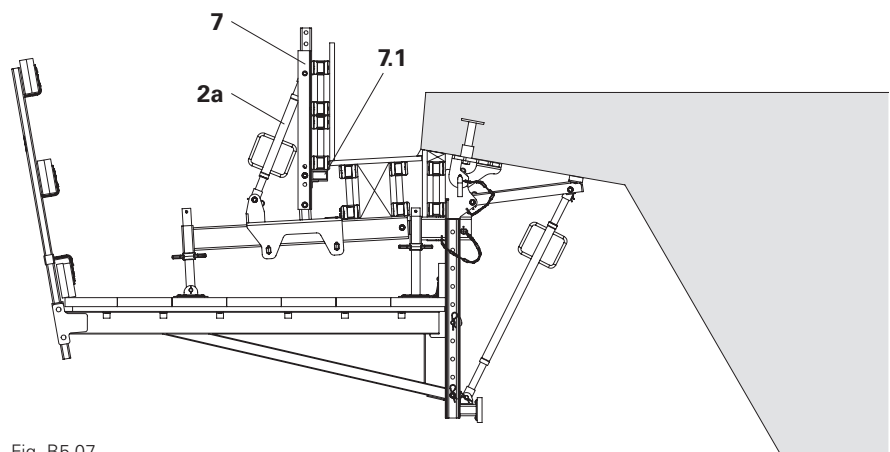

Fig. B5.07



## Arrangement of formwork girders



For optimal concreting results, offset the joints of formwork girders for the slab and side formwork. (Fig. B6.01)

Top view

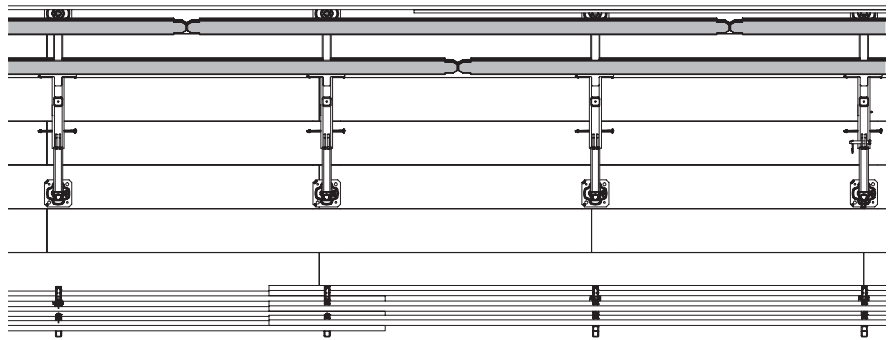

Fig. B6.01

## Forward inclination of the lateral formwork



The forward inclination "v" is dependent on the height of cantilevered parapet "H" and refers to the upper edge of the cantilevered parapet. (Fig. B6.02)

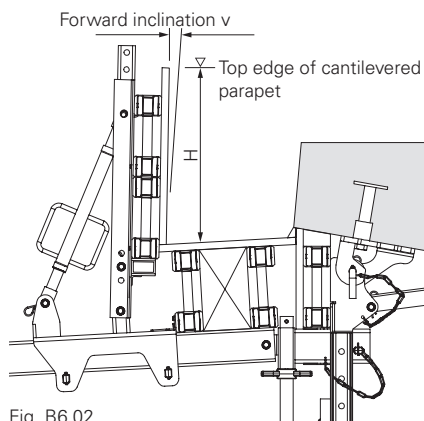

Fig. B6.02

Cantilevered parapet height H [cm]	Forward inclination v* [mm]
100	23
80	9
60	3
40	0

\*Values at 1 m influence width.  
Intermediate values can be interpolated linearly.

Tab. B6.01



## Danger

Danger associated with overloading!  
Cantilevered parapet brackets can fall to the ground.

- ⇒ Do not pour concrete directly from the mixer truck or concrete bucket into the formwork construction.
- ⇒ Avoid any accumulation of concrete in the area of the cantilevered parapet track. (Fig. C1.01)

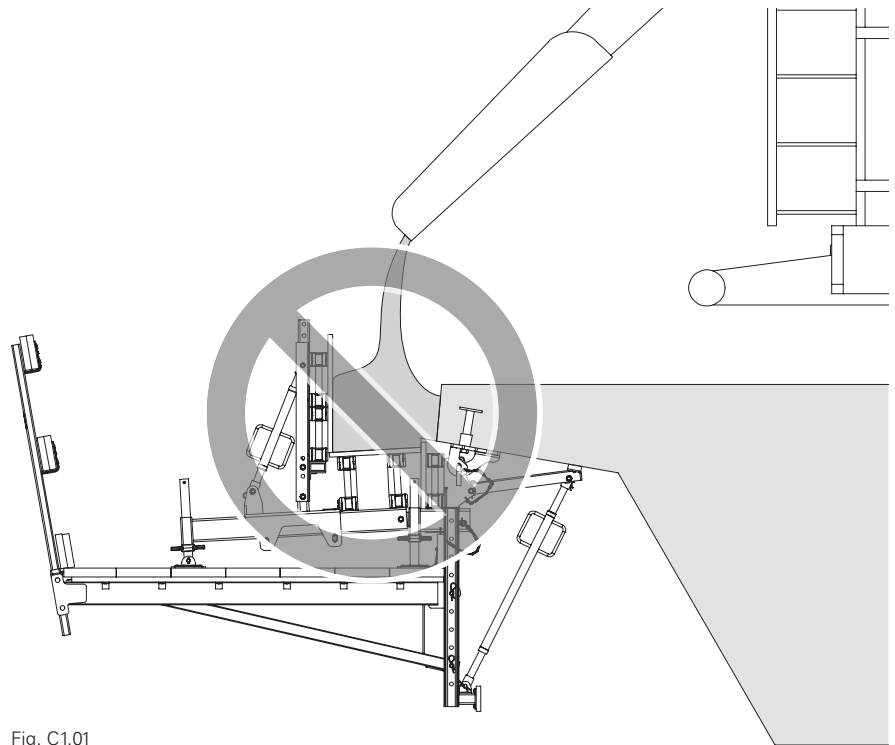

Fig. C1.01

## Concreting

1. Pour concrete on the bridge cantilever.
2. Bring concrete into the formwork construction using a rake or something similar.
3. Compact the concrete. (Fig. C1.02)

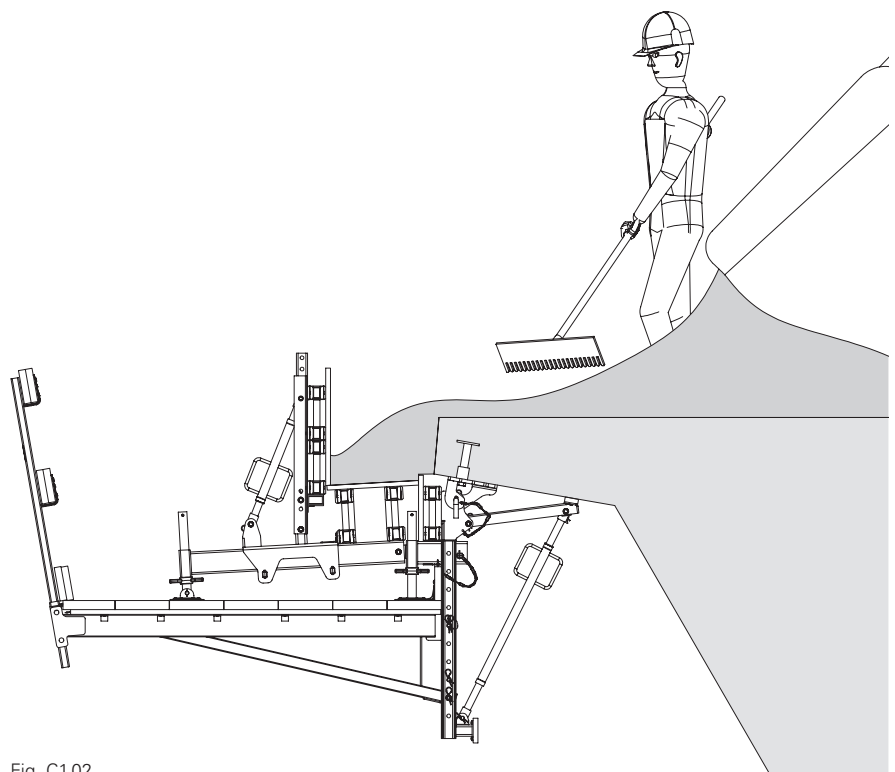

Fig. C1.02

## Formwork unit



- Striking and dismantling of the formwork unit is carried out from the platform unit.
- Deshuttering and dismantling is the same for all construction sizes using the reverse order of shuttering and assembly.

## Side plate

1. Turn back Formwork Post VGK 70 (7) with Kicker AV 82 (2a) until side plate comes off the cantilevered parapet.
2. Remove the side formwork. (Fig. C2.01)

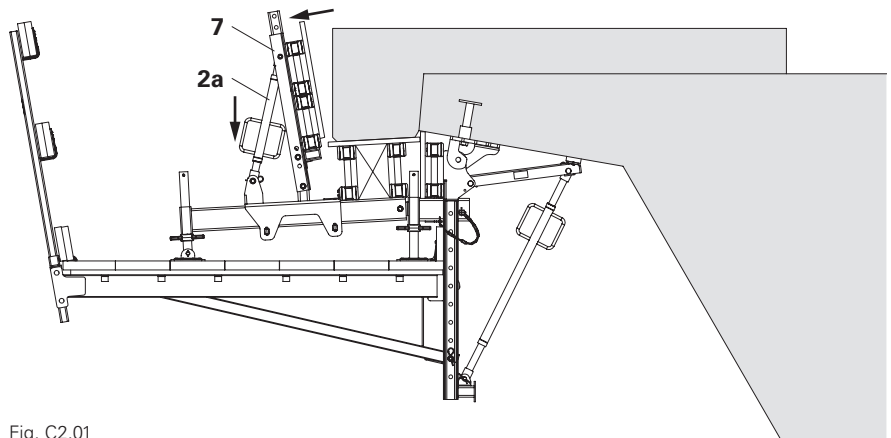

Fig. C2.01

## Slab formwork

1. Release wedge (5.1) on Formwork Fixing-2 VGK (5) and wedges (6.2) on Formwork Support VGK (6).
2. Turn spindle downwards until the slab formwork has been released from the cantilevered parapet. (Fig. C2.02)

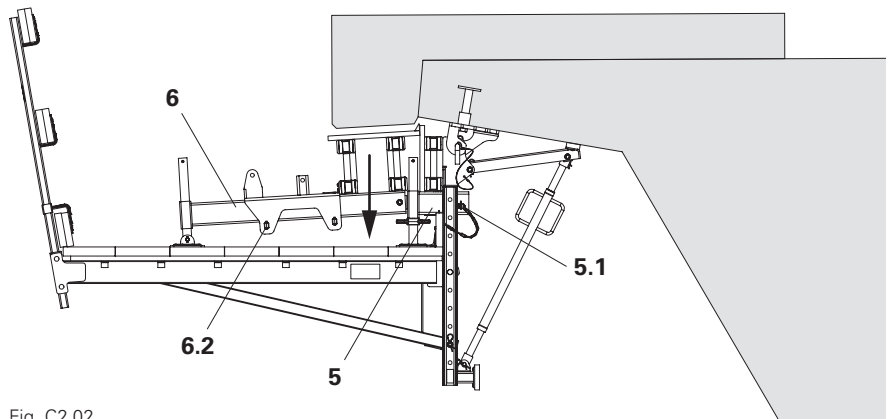

Fig. C2.02

## Formwork unit

1. Remove Formwork Post VGK 70 (7) and Kicker AV 82 (2a).
2. Remove floor formwork.
3. Remove Formwork Supports VGK 100 (6).
4. Remove Formwork Fixing-2 VGK (5) and internal formwork. (Fig. C2.03)

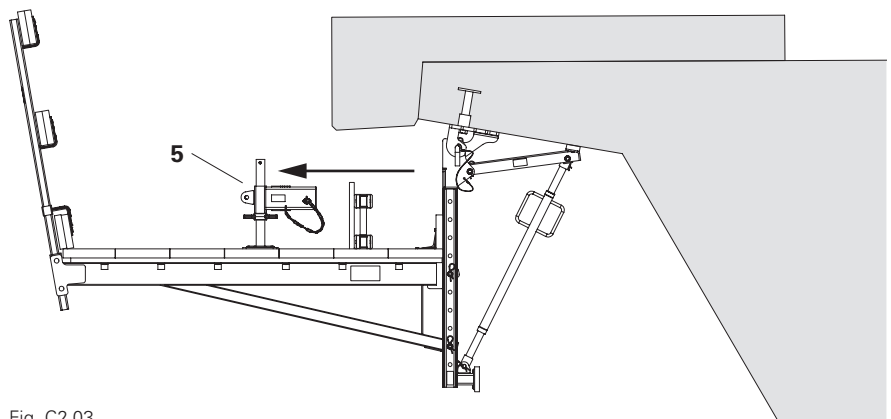

Fig. C2.03

## On the cantilever



### Danger

Leading edges are present during assembly!

There is a risk of falling off the cantilevered parapet.

- ⇒ Dismantle platform unit and platform unit from a safe and secure working area, e.g.:
- Telescopic work platform.
  - Temporary working scaffold.
  - Personal protective equipment to prevent falling from a height (PPE).



Depending on the stage of construction, temporary safety measures to prevent falling may be required.

### Platform unit

1. Remove guardrail boards (33) and Guardrail Post-2 HSGP (29).
2. Remove the planking (35) continuously. (Fig. C3.01)
3. Remove Platform Cantil. Beam VGK 170 (4).
4. Re-install bolts and cotter pins (1.3) in Bracket Post VGK (1). (Fig. C3.02)

### Bracket unit

1. Remove locking pins Ø20x260 mm (1.1) from Suspension Head VGK (12) and remove the bracket unit. (Fig. C3.03)
2. Place bracket console unit on the ground and dismantle.
3. Loosen Screw ISO 4014-M24x100-8.8-ga (16) and remove Suspension Head VGK (12).
4. Seal tie holes, for example with concrete plugs, see Section "A5 Anchoring" on page 39. (Fig. C3.04)

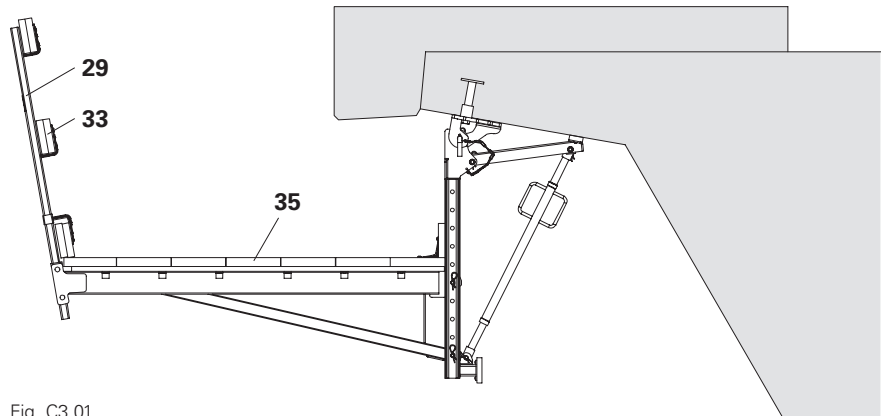

Fig. C3.01

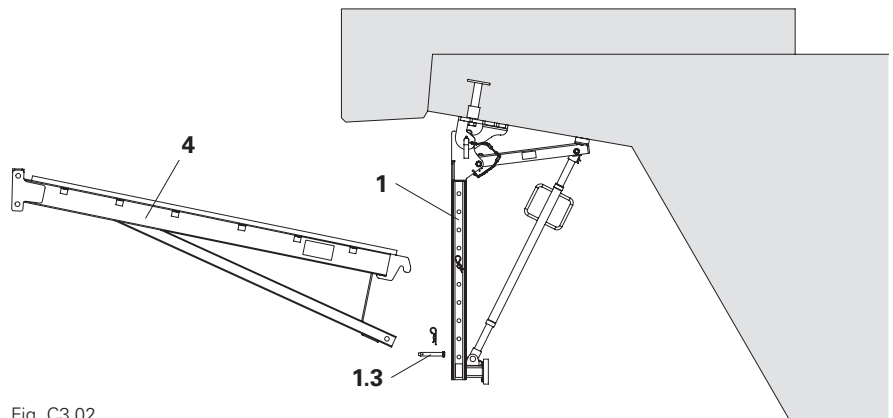

Fig. C3.02

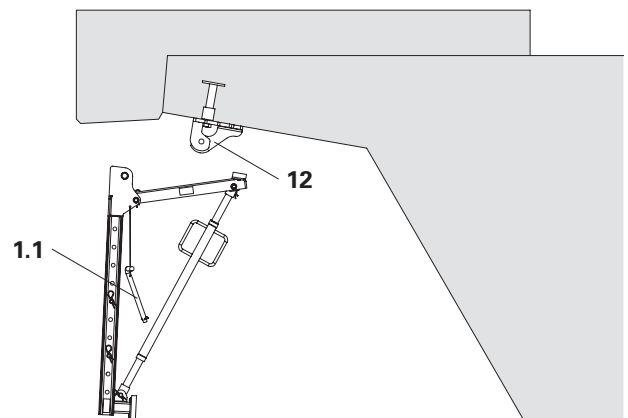

Fig. C3.03

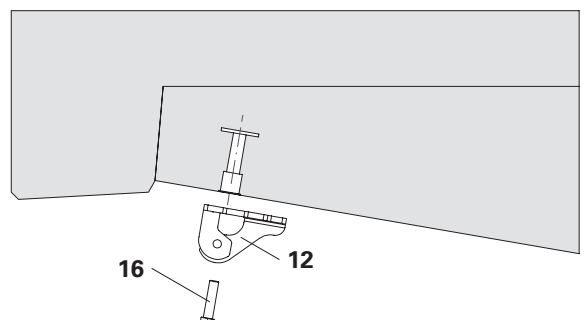

Fig. C3.04

## On the abutment



### Danger

Leading edges are present during assembly!

There is a risk of falling off the cantilevered parapet.

- ⇒ Dismantle platform unit and platform unit from a safe and secure working area, e.g.:
- Telescopic work platform.
  - Temporary working scaffold.
  - Personal protective equipment to prevent falling from a height (PPE).

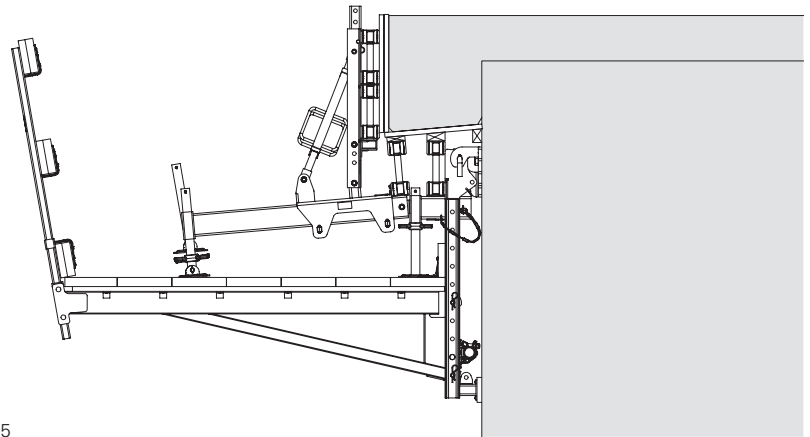

Fig. C3.05

Dismantling the cantilevered parapet bracket takes place in the same way as on the cantilever.

- Dismantle and remove the formwork unit. (Fig. C3.05)
- Dismantle and remove the platform unit. (Fig. C3.06)
- Dismantle and remove the bracket unit. (Fig. C3.07)
- Loosen Screw ISO 4014-M24x 070-10.9 (**23**) and remove Suspension Head VGK (**12**).
- Remove the ties and seal the tie holes, e.g. with concrete cones, see Section "A5 Anchoring" on page 38. (Fig. C3.08)

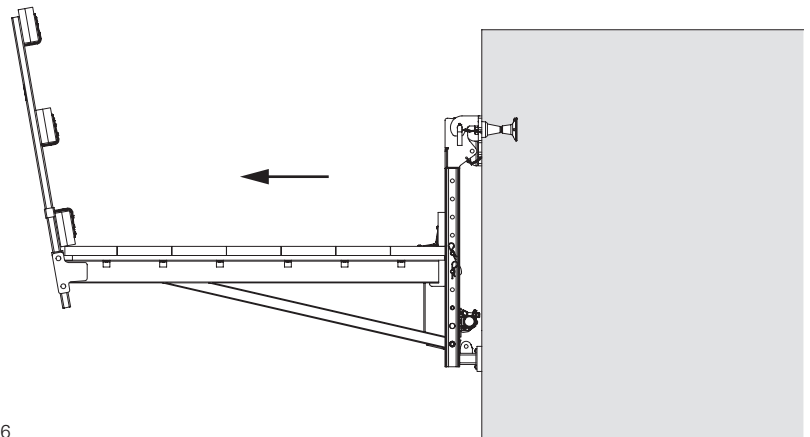

Fig. C3.06

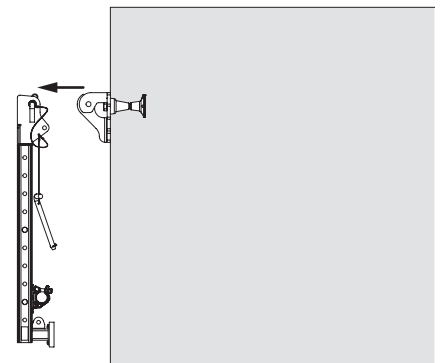

Fig. C3.07

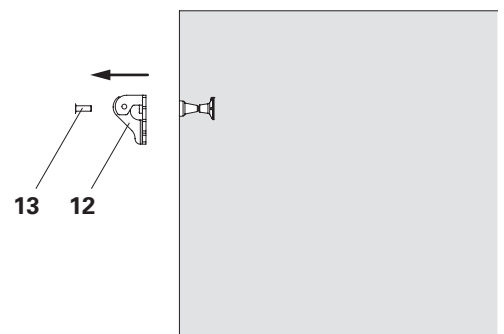

Fig. C3.08

## Guardrail Post GKB



### Danger

Unsecured concrete edge!

A fall can result in serious injuries or even death

Risk of falling.

- ⇒ Assembly and dismantling should take place from a safe and secure working area, e.g. lifting platform, or
- ⇒ Use PPE.



- All loads that arise must be safely transferred.
- Reinforcement stirrups must have sufficient load-bearing capacity.

The Guardrail Post GKB is to be used in accordance with EN 13374 for temporary fall protection on bridge edges. Create side protection railings according to Tab. C4.01 or Tab. C4.02.

Two fastening variants are available:

### Variant 1

The Guardrail Post GKB is clamped in the reinforcement stirrup. (Fig. C4.01)

### Required components

<b>25</b> Guardrail Post GKB	1x
<b>33</b> Guardrail boards	3x

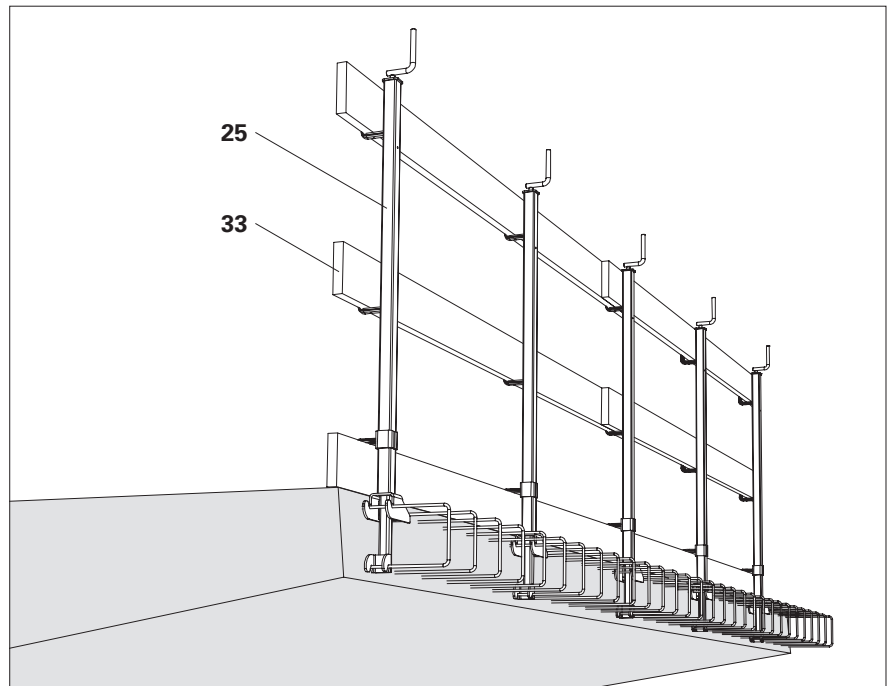

Fig. C4.01

### Permissible influence width for the guardrail posts

Handrail board h/b [cm]	Perm. width of influence* [m]
12/4	1.60
15/3	1.55

\* Values are valid only in compliance with the boundary conditions in Tab. C4.02 and Fig. C4.03

Tab. C4.01

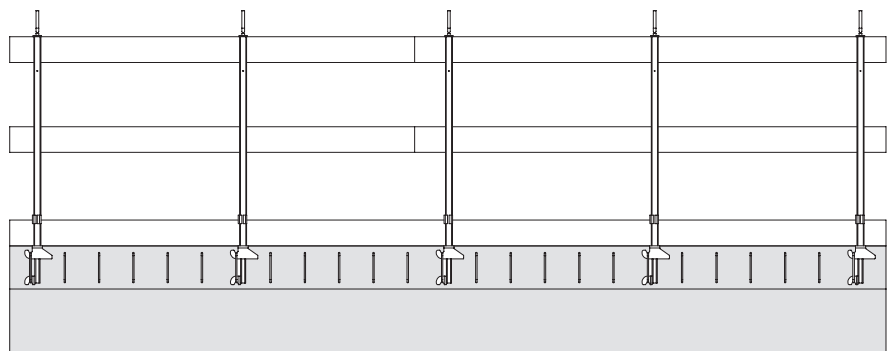

Fig. C4.01a

## Assembly

1. Pre-adjust Guardrail Post GKB (25) with the crank.
2. Place the Guardrail Post GKB (25) in the reinforcement stirrup and tension with the crank.
3. Position guardrail boards (33) and secure, e.g. by means of wire pins or wood screws.  
(Fig. C4.02 + Fig. C4.03)

## Disassembly

1. Turn crank until the lower holder is free and the guardrail post can be removed from the top reinforcement.

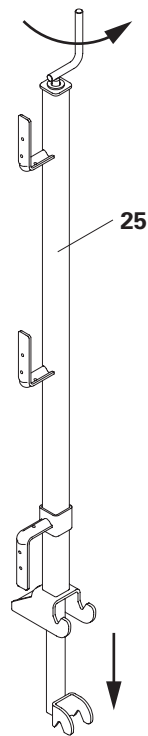

Fig. C4.02

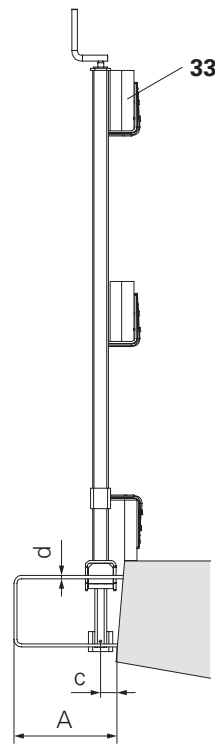

Fig. C4.03

Boundary conditions	
Tightening torque with the crank	$\geq 60 \text{ Nm}$
Reinforcement stirrup spacing A	$\geq 15 \text{ cm}$
Reinforcement stirrup diameter d	$\geq 12 \text{ mm}$
Distance between axis/guardrail post and front concrete side c	$\leq 6 \text{ cm}$

Tab. C4.02

## Variante 2

The Guardrail Post GKB is fixed to the parapet/bridge.  
(Fig. C4.04b)

### Required components

<b>25</b> Guardrail Post GKB	1x
<b>42</b> Screw-On Sleeve M16/164	1x
<b>43</b> Screw ISO 4017-M16x120-8.8-ga	1x
<b>44</b> Washer ISO 7094-16-100HV-ga	1x



- For installation of the Screw-On Sleeve M16/164 (**42**), see data sheet. (Fig. C4.06)
- Tighten Screw ISO 4017-M16x120-8.8 (**43**) together with Washer ISO 7094-16-100HV-ga. (**44**) and preload slightly. (Fig. C4.04 – Fig. C4.05)

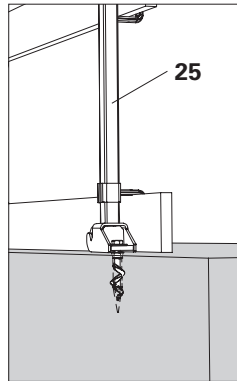

Fig. C4.04a

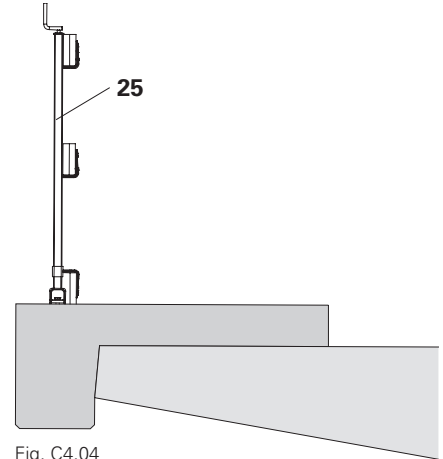

Fig. C4.04

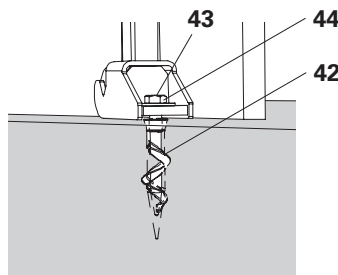

Fig. C4.04b

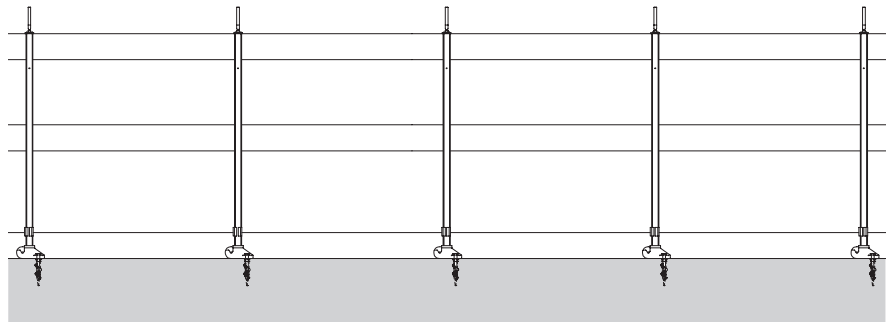

Fig. C4.05

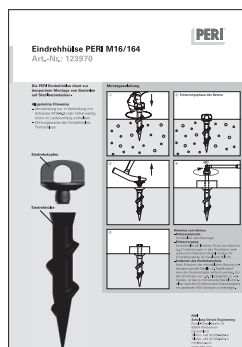

Fig. C4.06



## Permissible width of influence for the guardrail posts when using the Screw-On Sleeve



- The forces shown in the table can be linearly reduced or increased when using other anchoring methods with smaller or larger influence widths.
- The permissible influence width in variant 2 is limited:
  - Handrail board h/b = 12 cm/4 cm: perm. influence width = 1.50 m
  - Handrail board h/b = 15 cm/3 cm: perm. influence width = 1.20 m
- For handrail boards that extend across only 2 bays, the permissible influence width of the guardrail post is to be divided by 1.25.
- Safe transfer of existing forces into the building must be guaranteed.
- Take into account the manufacturer's information on the selected anchoring.

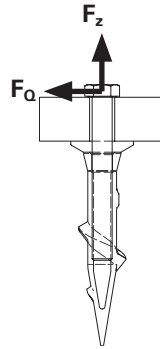

Guardrail boards h/b [cm]	permissible post spacing [m]	Tensile force $F_Z$ on anchoring [kN]	Shear force $F_Q$ on anchoring [kN]
12/4	1.20	9.89	0.53
15/3	0.95	9.74	0.53

Tab. C4.03



## Danger

The platform cannot take any concreting loads!

The platform could fall down and this could result in serious injuries or even death.

- ⇒ Do not use the platform as a formwork suspension.
- ⇒ Mount the formwork on the wall, e.g. with wall formwork bracket MX WK (66).
- ⇒ Only place the standing scaffold on Work Platform VGK 160.

(Fig. D1.02 + Fig. D1.02a)



- Permissible spindle loads on the deck:
    - $V1 = 3.40 \text{ kN}$
    - $V2 = 1.90 \text{ kN}$
- (Fig. D1.02)
- For the deck, use a multi-layer plywood sheet with a min. thickness of 39 mm thickness as per DIN EN 14374:2005-02.
  - The base spindles are at a distance of at least 20 cm from the wall-side corners of the decking panels. If this is not the case, fit additional distribution panels with minimum dimensions of 250 x 250 x 39 mm under the base spindles.
    - If the base spindle is resting on two decking panels, it can also be placed in the edge area.
- (Fig. D1.01)
- Other deck designs or higher spindle loads require planning, a separate structural verification of the VGK system and a risk assessment.

## Conditions for the standing scaffold:

- The standing scaffold must comply with DIN EN 12811-1:2004-03.
- The max. width of the standing scaffold is 1.25 m. Due to the reduced footprint, the standing scaffold is not consistent with a standard application. For this reason, separate structural verification was carried out for a max. platform height of 2.5 m. For platform heights above 2.5 m, the standing scaffold must be kept horizontal.
- The maximum decking width of the standing scaffold is 0.75 m.
- Permissible load of the standing scaffold according to load class 3 (DIN EN 12811-1:2004-03): Load assumption: 200 kg/m<sup>2</sup> on the upper scaffolding level and 100 kg/m<sup>2</sup> on the lower scaffolding level.
- The reinforcement scaffold meets the requirements of wind loads according to DIN EN 1004-1:2021-02 and DIN EN 12811-1:2004-03:
  - for free-standing scaffold:  $q = 0.1 \text{ kN/m}^2$  ( $v = 12.7 \text{ m/s}$ )
  - for scaffolds with a pressure brace against the formwork:  $q = 0.2 \text{ kN/m}^2$  ( $v = 17.9 \text{ m/s}$ )
- Dismantle the scaffold before higher anticipated wind forces or at the end of work operations, or fasten it to the supported and appropriately anchored formwork in such a way that it is tension- and compression-proof.
- Secure scaffold areas projecting over the formwork separately.
- Covering with tarpaulins or nets is not permitted.
- The weight of the standing scaffold used must not deviate significantly from the adopted PERI UP Flex scaffolding system.

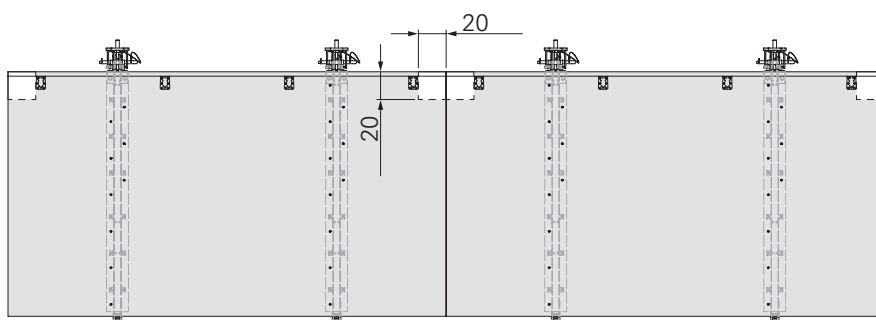

Fig. D1.01

## Base spindle footprint

Grey area:

- Permissible footprint

White area:

- Impermissible footprint



If the base spindle is resting on two decking panels, it can also be placed in the white area.

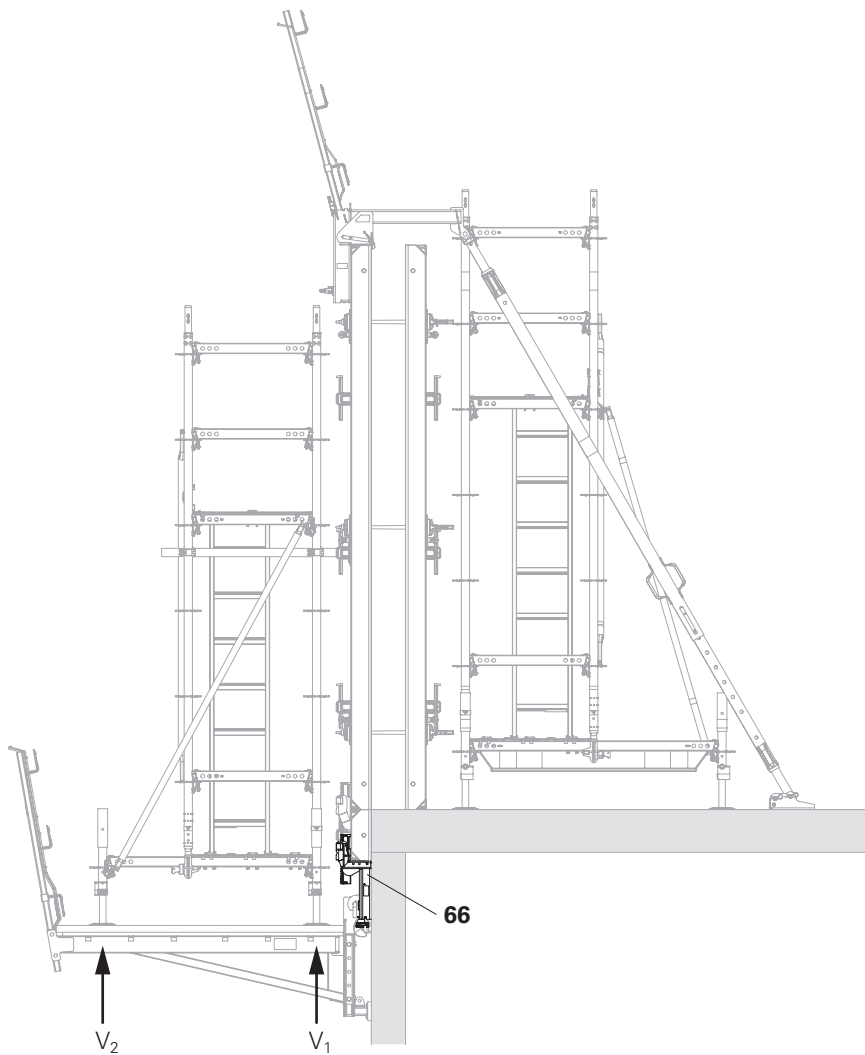

Fig. D1.02

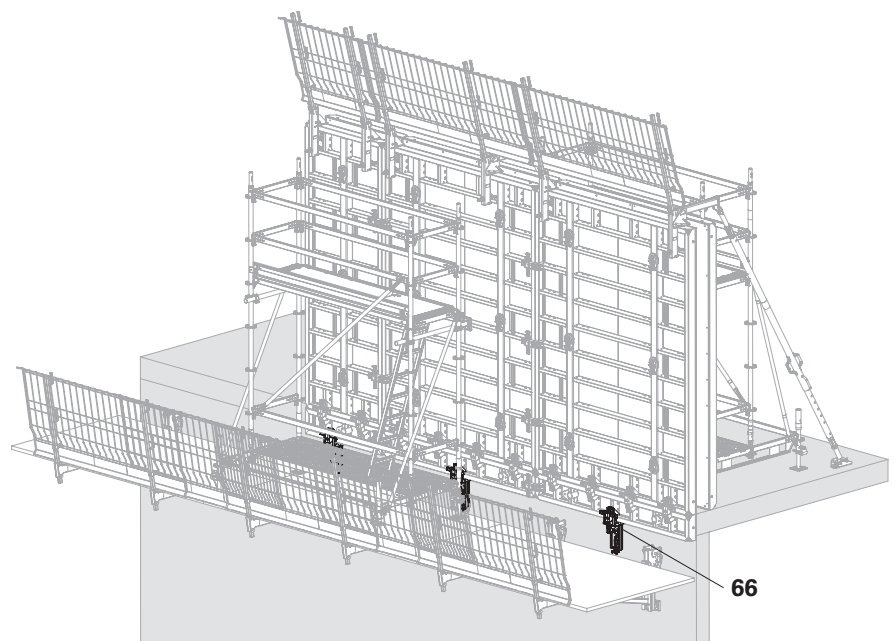

Fig. D1.02a

# VGK Bracket System

Art no.    Weight [kg]

124413    4.400    **Suspension Head VGK**

To attach the Bracket Post VGK 070/110/139 to the structure.

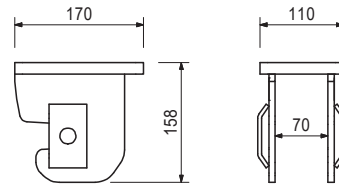
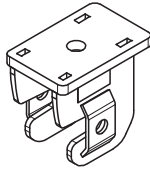

Art no.    Weight [kg]

138071    4.900    **Suspension Head VGK Flex**

To attach the Bracket Post VGK 70/110/139 to the structure in the form of pre-assembled platforms.

**Notes**

Not suitable for the Bracket Post VGK 70 in conjunction with Formwork Girder VGK 60 at the abutment.

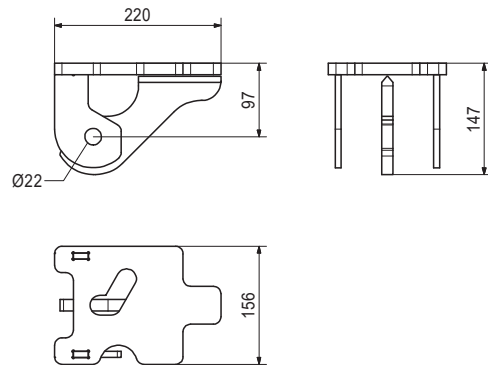
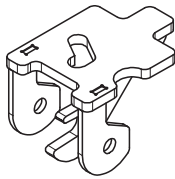

Art no.    Weight [kg]

134161    11.900    **Bracket Post VGK 70**

For connection of Platform Cantilever Beam VGK 170 and formwork with a parapet height up to 60 cm and low clearance profile.

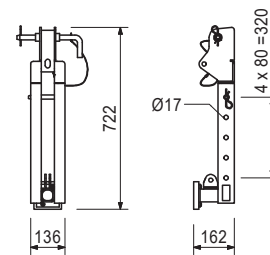

**Consists of**

- 1 pc 118463 Pin Ø16x90 mm coat
- 1 pc 113012 Locking Pin Ø20x260 mm coat
- 2 pc 018060 Cotter Pin 4/1 ga

# VGK Bracket System

Art no.    Weight [kg]

124404    17.300    **Bracket Post VGK 110**

For connection of Platform Cantilever Beam VGK 170 and formwork with a parapet height up to 60 cm.

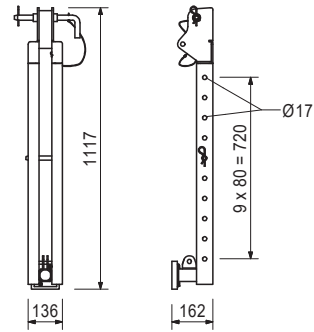

### Consists of

- 1 pc 118463 Pin Ø16x90 mm coat
- 1 pc 113012 Locking Pin Ø20x260 mm coat
- 2 pc 018060 Cotter Pin 4/1 ga

Art no.    Weight [kg]

124427    22.000    **Bracket Post VGK 139**

For connection of Platform Cantilever Beam VGK 170 and formwork with parapet heights from 60 cm to 100 cm.

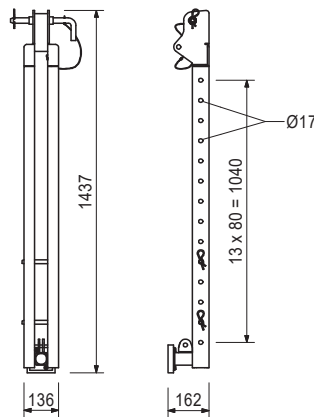

### Consists of

- 2 pc 118463 Pin Ø16x90 mm coat
- 1 pc 113012 Locking Pin Ø20x260 mm coat
- 3 pc 018060 Cotter Pin 4/1 ga

# VGK Bracket System

Art no. Weight [kg]

134173	0.478	<b>Anchor VGK B15</b>
--------	-------	-----------------------

To attach VGK Cantilevered Parapet Bracket to the anchor system in accordance with General Building Approval No. Z-21.6-1764 with installation length  $h_{nom} = 125$  mm.

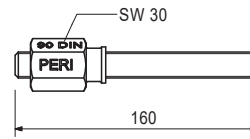
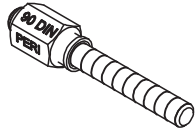

Art no. Weight [kg]

115378	1.080	<b>Eye Nut RCS DW15</b>
--------	-------	-------------------------

As an articulated connection to the Climbing Rail RCS, Steel Waler SRU for bracing with DW15.

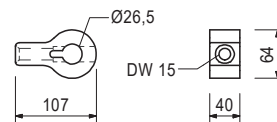

Accessory (not included)

104031	0.462	<b>Filler Pin Ø21x120 mm</b>
018060	0.014	<b>Cotter Pin 4/1 ga</b>
111567	0.729	<b>Filler Pin Ø26x120 mm</b>
022230	0.033	<b>Cotter Pin 5/1 ga</b>

Art no. Weight [kg]

710671	0.345	<b>Suspension Link A13</b>
--------	-------	----------------------------

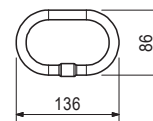

Art no. Weight [kg]

118463	0.181	<b>Pin Ø16x90 mm coat</b>
--------	-------	---------------------------

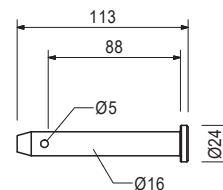
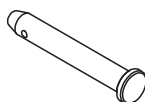

Art no. Weight [kg]

018060	0.014	<b>Cotter Pin 4/1 ga</b>
--------	-------	--------------------------



# VGK Bracket System

Art no.	Weight [kg]	
030070	0.222	<b>Hex-Nut DW15 SW30 50 mm ga</b>

For anchoring with Tie Rod DW15 and B15.

**Notes**

Weldable!

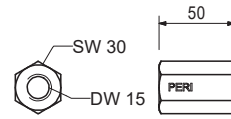

Art no.	Weight [kg]	
026230	1.010	<b>Anchor Sleeve M24</b>

For anchoring of platform systems.

**Notes**

Separate design information on request.

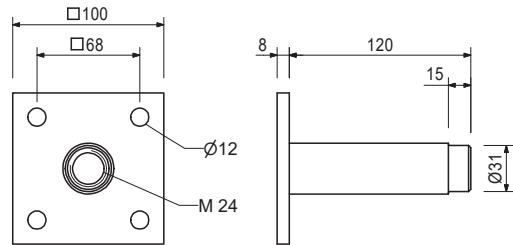
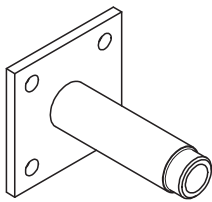

Accessory (not included)

026240	0.026	<b>Cone PP Ø31/26 mm C=25 mm</b>
026250	0.005	<b>Plug PP Ø26</b>
116233	0.116	<b>Cone FRC Ø32/52 mm C=40</b>
026420	0.123	<b>Anchor Posit. Stud M24 ga</b>
116234	0.033	<b>Concrete Plug Ø32 mm</b>
115150	0.200	<b>Anchor Position. M24x65 mm</b>
123800	0.045	<b>Threaded Cone M24/40 mm</b>

Art no.	Weight [kg]	
116233	0.116	<b>Cone FRC Ø32/52 mm C=40</b>

Results in concrete cover of 40 mm in combination with Tie Sleeve M24. Made of fibre-reinforced concrete.

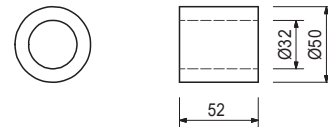
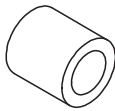

Art no.	Weight [kg]	
026240	0.026	<b>Cone PP Ø31/26 mm C=25 mm</b>

Results in concrete cover of 25 mm in combination with Tie Sleeve M24. Made of polypropylene.

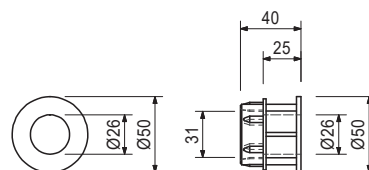

# VGK Bracket System

Art no.	Weight [kg]	
115150	0.200	<b>Anchor Position. M24x65 mm</b>

For fixing the Anchor Sleeve M24 if fixation through formlining is not possible.

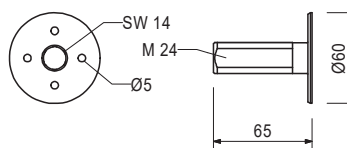
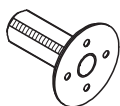

Art no.	Weight [kg]	
124031	0.452	<b>Screw ISO 4014-M24x100-8.8-ga</b>

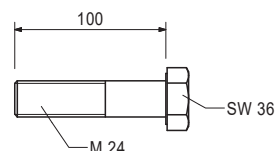
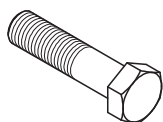

Art no.	Weight [kg]	
123800	0.045	<b>Threaded Cone M24/40 mm</b>

For pre-fixing of Anchor Sleeve M24 with a concrete cover of 40 mm in bridge cantilevers

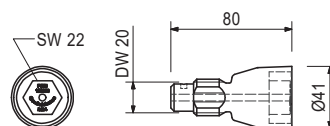
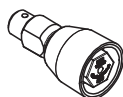

Accessory (not included)

026230	1.010	<b>Anchor Sleeve M24</b>
123820	0.063	<b>Concrete Plug Ø40 mm</b>
129157	0.017	<b>Wire Nail 4.6x130 mm</b>

Art no.	Weight [kg]	
129157	0.017	<b>Wire Nail 4.6x130 mm</b>

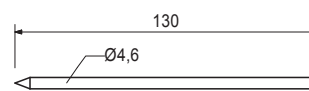
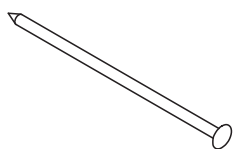

Art no.	Weight [kg]	
710312	0.005	<b>Wire Nail 3.0x80 mm</b>

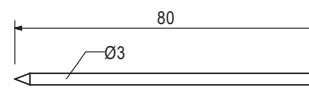
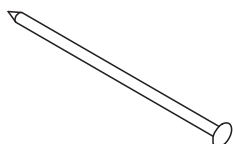



# VGK Bracket System

Art no. Weight [kg]

123820 0.063 **Concrete Plug Ø40 mm**

For closing the tie hole when using Threaded Cone M24.

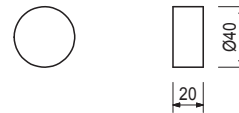

Art no. Weight [kg]

116234 0.033 **Concrete Plug Ø32 mm**

For closing the FRC Tube Ø32 mm. Made of fibre-reinforced concrete.

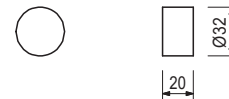

Art no. Weight [kg]

031550 1.000 **Repoxal Glue**

Two-component adhesive for bonding fibre-reinforced concrete plugs. Requirements: 1 kg adhesive for approx. 200 Plugs FZR 32 or 330 Plugs FZR 22.

**Notes**

See Safety Data sheet!  
Delivery unit 1 kg.

Art no. Weight [kg]

123970 0.047 **Screw-on Sleeve M16/164**

For temporary mounting of components on reinforced concrete slabs.

**Notes**

Inserted into the fresh concrete immediately after concreting.

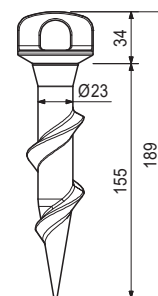

Accessory (not included)

123973 0.240 **Screw ISO 4017-M16x130-8.8-ga**

# VGK Bracket System

Art no.	Weight [kg]	
029280	0.196	<b>Anchor Posit. Stud M24 ga</b>

For fixing the Anchor System M24 if the plywood formlining has been drilled through.

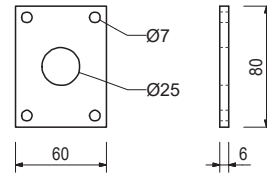
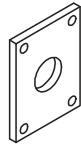

Accessory (not included)

029440	0.005	<b>Hex-Wood-Screw 6x20 DIN571-ga</b>
--------	-------	--------------------------------------

Art no.	Weight [kg]	
029270	0.331	<b>Advancing Screw M24 ga</b>

For fixing the Anchor System M24 if the plywood formlining has been drilled through.

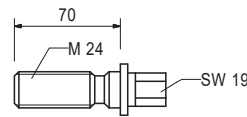
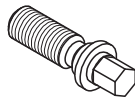

Accessory (not included)

029280	0.196	<b>Anchor Posit. Stud M24 ga</b>
--------	-------	----------------------------------

Art no.	Weight [kg]		L [mm]
029440	0.005	<b>Hex-Wood-Screw 6x20 DIN571-ga</b>	20

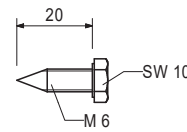

Art no.	Weight [kg]	
030860	0.792	<b>Threaded Anchor Plate DW20</b>

For use with Tie Rod DW20, B20 or Screw-On Cone-2 M24/DW20. For anchoring in concrete.

## Notes

Lost anchor part.

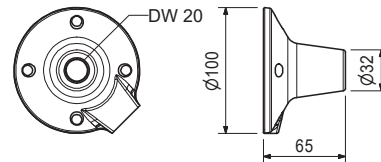
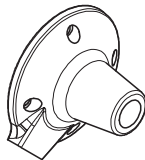

# VGK Bracket System

Art no.	Weight [kg]	
114158	1.030	<b>Screw-On Cone-2 M24/DW20</b>

Anchor System M24. For anchoring climbing systems.

**Notes**

Separate design information on request.

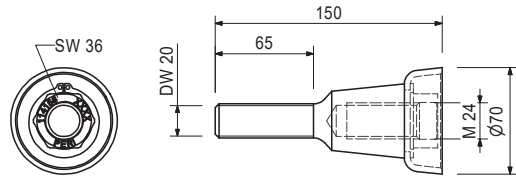
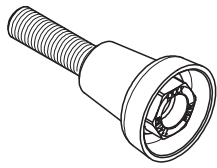

Accessory (not included)

030860	0.792	<b>Threaded Anchor Plate DW20</b>
--------	-------	-----------------------------------

Art no.	Weight [kg]	
026420	0.123	<b>Anchor Posit. Stud M24 ga</b>

For fixing Anchor System M24 if the plywood formlining is not to be drilled through.

**Notes**

Allen Key SW14.

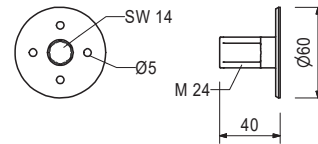

Accessory (not included)

027212	0.445	<b>Hexag. Recess Wrench SW14 long</b>
710312	0.005	<b>Wire Nail 3.0x80 mm</b>

Art no.	Weight [kg]		L [mm]
026430	0.334	<b>Screw ISO 4014-M24x070-10.9</b>	70

High-strength bolt for anchoring climbing systems.

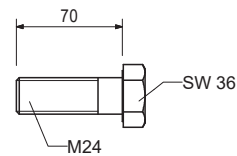
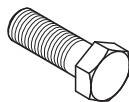

Art no.	Weight [kg]	
031652	0.247	<b>KK Concrete Cone M24 Ø67/52 mm</b>

For closing anchor points with Climbing Cone-2, M24/DW15 and Screw-On Cone-2 M24/DW20.

**Notes**

Delivery unit 50 pieces.

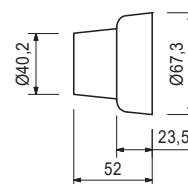
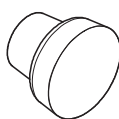

Accessory (not included)

131709	9.980	<b>Sealing Adhesive-3 6 Cans-Set</b>
--------	-------	--------------------------------------

# VGK Bracket System

Art no.    Weight [kg]

131709    9.980    **Sealing Adhesive-3 6 Cans-Set**

For bonding PERI Concrete Cones.

### Notes

See Safety Data sheet!

Consisting of: 6 x Component A, 6 x Component B

Component A = Net quantity / Can 459 ml / 752 g

Component B = Net quantity / Can 356 ml / 583 g

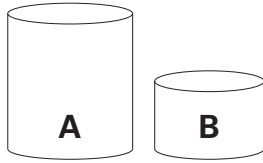

### Consists of

6 pc 131710 Sealing Adhesive-3 Can CO-A

6 pc 131711 Sealing Adhesive-3 Can CO-B

Art no.    Weight [kg]

114299    9.520    **Guardrail Post GKB**

For fixing to the reinforcement or to the embedded anchors.

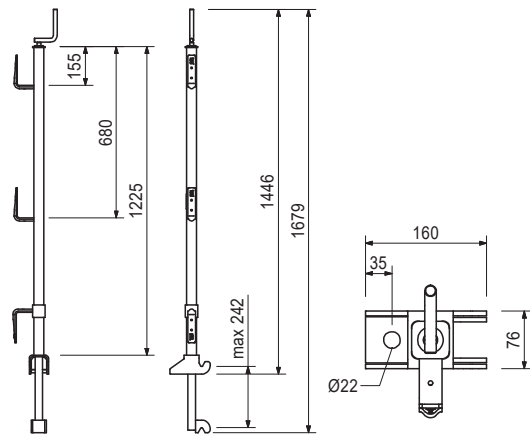

Art no.    Weight [kg]

130012    0.337    **Connection Bolt M16/M24x50**

Refurbishment anchor for subsequent attachment of Suspension Head VGK to existing bridge structures.

### Notes

Separate design information on request.



# VGK Bracket System

Art no.	Weight [kg]	
129637	0.195	<b>ITH-Sleeve TSM BC 22x75 mm IM16</b>

Internal threaded sleeve for connection bolt M16/M24x50.

**Notes**

Separate design information on request.



Art no.	Weight [kg]	
129628	0.555	<b>Composite Mortar CF-T 300 V</b>

Consumption: approx. 15 anchors / 410 ml.



Accessory (not included)

130013	0.010	<b>Mixer CF-T 300 V</b>
--------	-------	-------------------------

Art no.	Weight [kg]	
130013	0.010	<b>Mixer CF-T 300 V</b>



Art no.	Weight [kg]	
130014	1.160	<b>Dispenser CF-T 300 V</b>



Art no.	Weight [kg]	
130015	0.277	<b>Blow Out Pump</b>



# VGK Bracket System

Art no.	Weight [kg]	
130011	0.084	<b>Cleaning Brush D24</b>



Accessory (not included)

130623	0.016	<b>T-Handle M6</b>
--------	-------	--------------------



Art no.	Weight [kg]	
130623	0.016	<b>T-Handle M6</b>

Art no.	Weight [kg]	
105032	0.070	<b>Hex-Nut ISO 7040-M24-8-ga</b>

Self-locking.

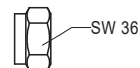

Art no.	Weight [kg]		L [mm]
<b>Wood-Screws SK-TX30 HPI</b>			
024470	0.008	<b>Wood-Screw 6x60 SK-TX30 HPI</b>	60
024690	0.008	<b>Wood-Screw 6x80 SK-TX30 HPI</b>	80

For Torx Bit Points TX30. Self-drilling.

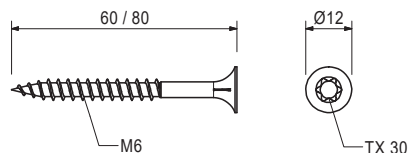
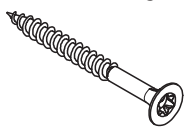

Art no.	Weight [kg]	
113349	0.087	<b>Washer ISO 7094-16 100HV-ga.</b>

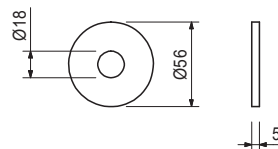

# VGK Bracket System

Art no.    Weight [kg]

		<b>Tie Rods DW15</b>
030050	0.000	<b>Cutting Cost DW15/B15</b>
030030	1.440	<b>Tie Rod DW15 spec. Length</b>
030340	4.480	<b>Tie Rod DW26 spec. Length</b>

## Notes

Non-weldable! Take official approval into consideration! Permissible tension force 250 kN.

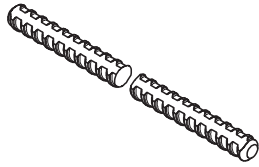

# VGK Bracket System

Art no.	Weight [kg]		L [mm]
<b>Girders GT 24</b>			
075100	5.300	<b>Girder GT 24 90</b>	918
075120	7.100	<b>Girder GT 24 120</b>	1214
075150	8.900	<b>Girder GT 24 150</b>	1510
075180	10.600	<b>Girder GT 24 180</b>	1806
075210	12.400	<b>Girder GT 24 210</b>	2102
075240	14.200	<b>Girder GT 24 240</b>	2398
075270	15.900	<b>Girder GT 24 270</b>	2694
075300	17.700	<b>Girder GT 24 300</b>	2990
075330	19.500	<b>Girder GT 24 330</b>	3286
075360	21.200	<b>Girder GT 24 360</b>	3582
075390	23.000	<b>Girder GT 24 390</b>	3878
075420	24.800	<b>Girder GT 24 420</b>	4174
075450	26.600	<b>Girder GT 24 450</b>	4470
075480	28.300	<b>Girder GT 24 480</b>	4766
075510	30.100	<b>Girder GT 24 510</b>	5062
075540	31.900	<b>Girder GT 24 540</b>	5358
075570	33.600	<b>Girder GT 24 570</b>	5654
075600	35.400	<b>Girder GT 24 600</b>	5950

Universal formwork girder made of wood.

## Notes

Special lengths over 6 m are possible and can be provided on request.

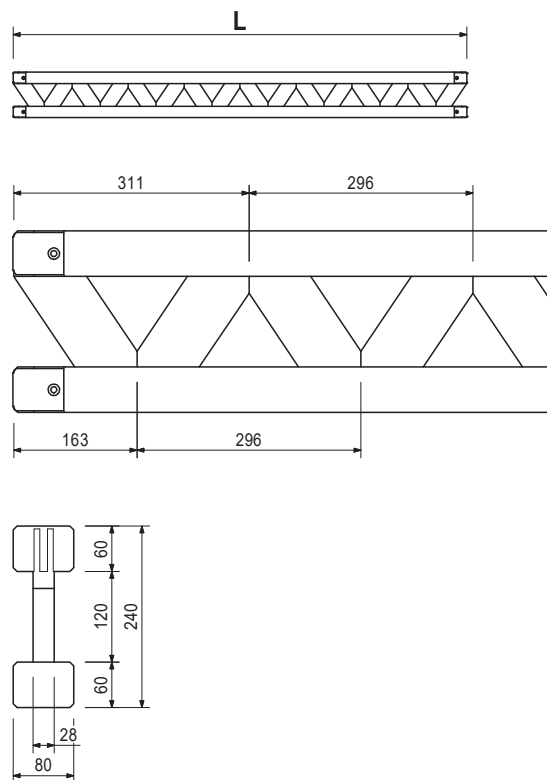
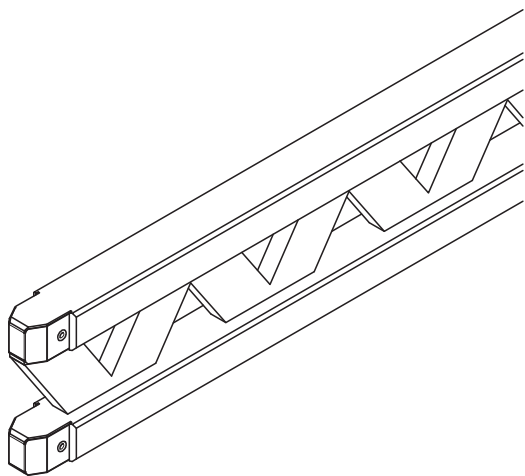



# VGK Bracket System

Art no.	Weight [kg]		L [mm]
<b>Girders VT 20K with Steel Cap</b>			
074990	8.230	<b>Girder VT 20K 145</b>	1447
074905	12.010	<b>Girder VT 20K 215</b>	2152
074910	13.630	<b>Girder VT 20K 245</b>	2452
074890	14.710	<b>Girder VT 20K 265</b>	2652
074920	16.060	<b>Girder VT 20K 290</b>	2902
074930	18.220	<b>Girder VT 20K 330</b>	3292
074940	19.840	<b>Girder VT 20K 360</b>	3592
074950	21.460	<b>Girder VT 20K 390</b>	3892
074960	24.700	<b>Girder VT 20K 450</b>	4492
074970	26.860	<b>Girder VT 20K 490</b>	4902
074980	32.260	<b>Girder VT 20K 590</b>	5902

Universal formwork girder made of wood.

### Notes

The girder fulfils all requirements of DIN EN 13377 class P20 (Declaration of Conformity).

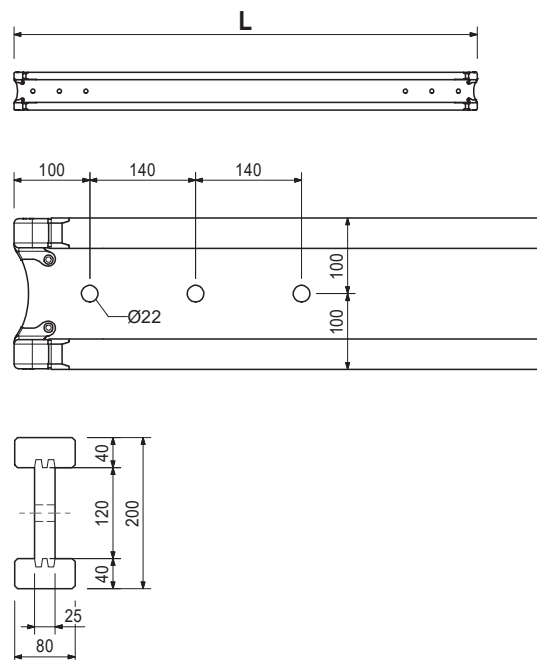
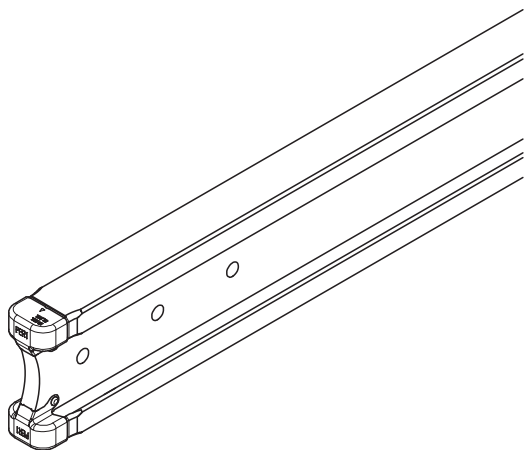

Art no.	Weight [kg]	
074900	0.000	<b>Cutting Cost for VT Girder</b>

# VGK Bracket System

Art no.	Weight [kg]		min. L [mm]	max. L [mm]
<b>Kicker Braces AV</b>				
057087	3.510	<b>Kicker AV 82</b>	500	820
057088	4.200	<b>Kicker AV 111</b>	790	1110

For aligning PERI Formwork Systems.

**Notes**

Permissible load see PERI Design Tables.

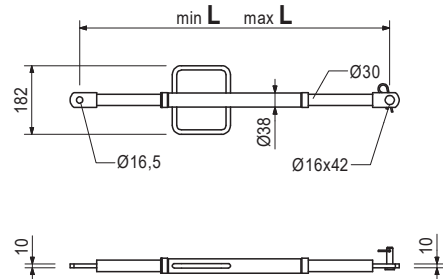
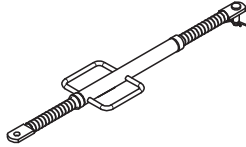

**Consists of**

- 1 pc 027170 Pin Ø16x42 mm ga
- 1 pc 018060 Cotter Pin 4/1 ga

Art no.	Weight [kg]		D [mm]	L [mm]	min. L [mm]	max. L [mm]
028110	4.850	<b>Kicker AV 140</b>	2000	250	1080	1400

For aligning PERI Formwork Systems.

**Notes**

Permissible load see PERI Design Tables.

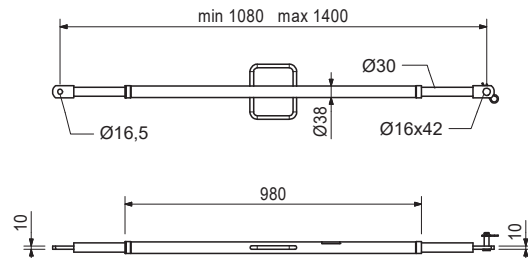
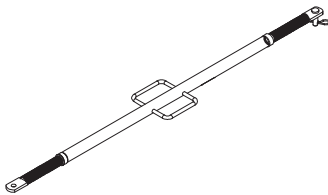

**Consists of**

- 1 pc 027170 Pin Ø16x42 mm ga
- 1 pc 018060 Cotter Pin 4/1 ga

Art no.	Weight [kg]	
124455	3.050	<b>Bracket Cantilever VGK 50</b>

For assembly of the bracket unit with Bracket Post VGK 70/110/139 and Kicker Brace AV 82/111/140.

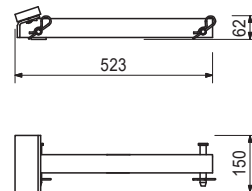
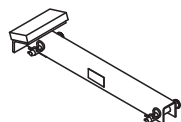

**Consists of**

- 2 pc 118463 Pin Ø16x90 mm coat
- 2 pc 018060 Cotter Pin 4/1 ga

# VGK Bracket System

Art no. Weight [kg]

124447 21.100 **Platform Cantil. Beam VGK 170**

For connection to the Bracket Post VGK 70/110/139 and installation of a fully closed platform planking.

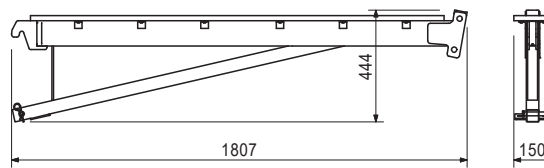
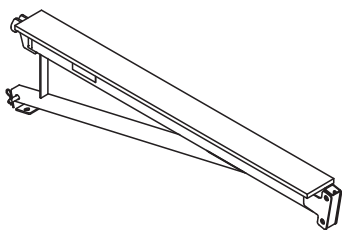

### Consists of

- 1 pc 118463 Pin Ø16x90 mm coat
- 1 pc 018060 Cotter Pin 4/1 ga

Art no. Weight [kg]

138056 1.900 **Guardrail Holder VGK**

For assembling a guardrail to the Formwork Posts VGK 70 and 120

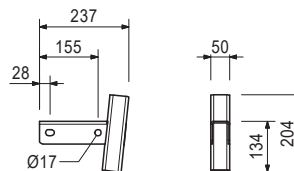

Art no. Weight [kg]

061260 6.150 **Guardrail Post SGP**

As guardrail for different systems.

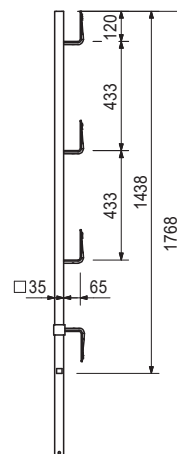

# VGK Bracket System

Art no. Weight [kg]

116292	4.720	<b>Guardrail Post-2 HSGP</b>
--------	-------	------------------------------

As guardrail for different systems.

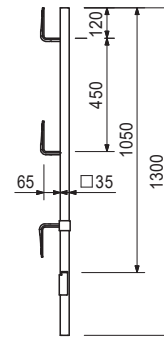

Art no. Weight [kg]

114328	16.600	<b>Guardrail Post RCS/SRU 184</b>
--------	--------	-----------------------------------

For assembly of the guardrail on the Platform Beam RCS/SRU or Guardrail Post Holder Multi.

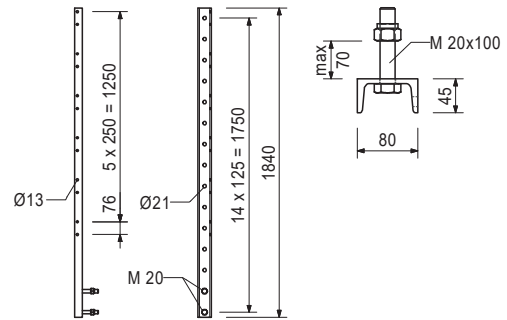

Accessory (not included)

110296	0.220	<b>Clamp A64 DIN3570-M12-ga</b>
710330	0.017	<b>Hex-Nut ISO 4032-M12-8-ga</b>
710709	0.036	<b>Screw DIN603-M08-065-4.8-ga-Nut</b>
780354	0.002	<b>Washer ISO 7089-08-200HV-ga</b>
057345	0.010	<b>Washer 9 mm DIN 434 ga</b>

### Consists of

- 2 pc 114727 Screw ISO 4017-M20x100-8-8-ga
- 2 pc 781053 Hex-Nut ISO 7040-M20-8-ga

Art no. Weight [kg]

124394	6.640	<b>Formwork Fixing-2 VGK</b>
--------	-------	------------------------------

For connection of the Formwork Support VGK 100 to the Bracket Post VGK 110/139.

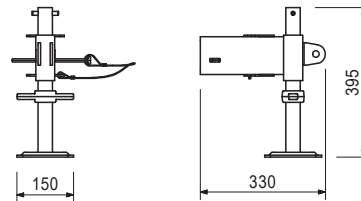
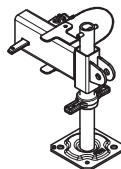

# VGK Bracket System

Art no. Weight [kg]

134169 7.650 **Formwork Support VGK 60**

For connection of bottom and lateral formwork in combination with Bracket Post VGK 70.

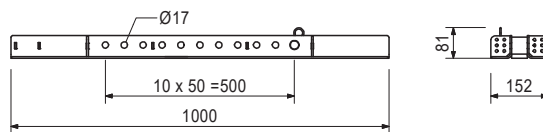
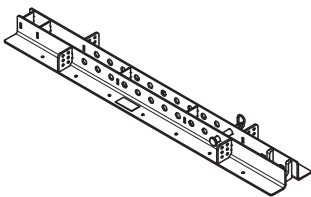

### Consists of

- 1 pc 118463 Pin Ø16x90 mm coat
- 1 pc 018060 Cotter Pin 4/1 ga

Art no. Weight [kg]

124438 20.100 **Formwork Support VGK 100**

For connection of the bottom and lateral formwork.

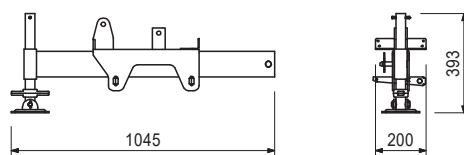
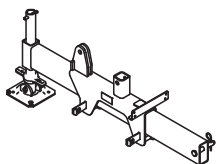

### Consists of

- 1 pc 118463 Pin Ø16x90 mm coat
- 1 pc 018060 Cotter Pin 4/1 ga

Art no. Weight [kg]

124371 7.300 **Formwork Post VGK 70**

For mounting lateral formwork.

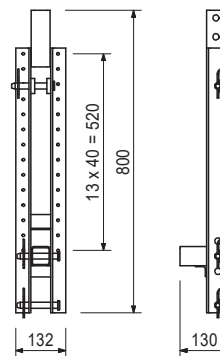

### Consists of

- 1 pc 124364 Girder Support coat
- 3 pc 118463 Pin Ø16x90 mm coat
- 3 pc 018060 Cotter Pin 4/1 ga

# VGK Bracket System

Art no.    Weight [kg]

138061	10.200	<b>Formwork Post VGK 120</b>
--------	--------	------------------------------

For mounting lateral formwork for parapets ranging from 60 cm-100 cm and a platform beam when using the lightweight working platform

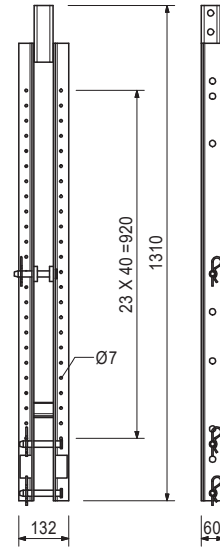

Accessory (not included)

124364	0.608	<b>Girder Support coat</b>
118463	0.181	<b>Pin Ø16x90 mm coat</b>
018060	0.014	<b>Cotter Pin 4/1 ga</b>

### Consists of

- 3 pc 118463 Pin Ø16x90 mm coat
- 3 pc 018060 Cotter Pin 4/1 ga

Art no.    Weight [kg]

124364	0.608	<b>Girder Support coat</b>
--------	-------	----------------------------

Can be assembled on VGK 120 Formwork Support. Serves as support for formwork beams.

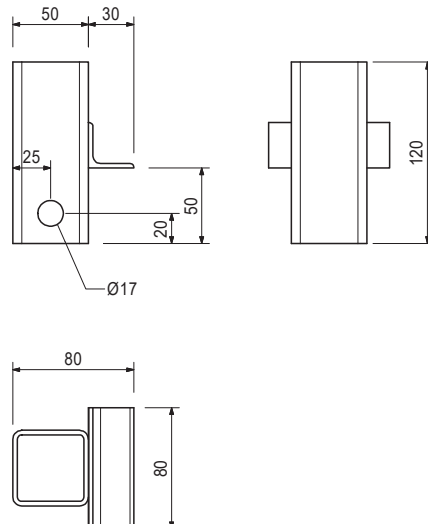
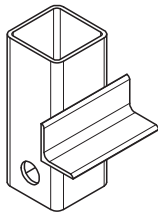

# VGK Bracket System

Art no.	Weight [kg]		W [mm]	L [mm]
138455	1.840	<b>Bracing Shoe VGK</b>	85	192

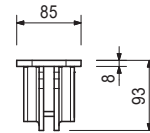
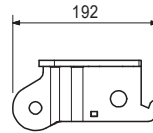
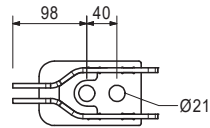
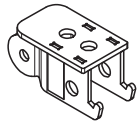

Accessory (not included)

124777	0.210	<b>Anchor Bolt Ø14/20x130 mm</b>
--------	-------	----------------------------------

Art no.	Weight [kg]	
124777	0.210	<b>Anchor Bolt Ø14/20x130 mm</b>

For temporary attachment to reinforced concrete components.

**Notes**

Take the PERI Data Sheet into consideration!  
Hole Ø14 mm.

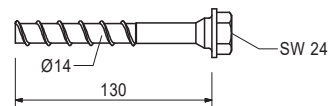
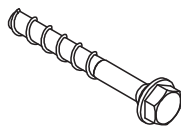

Art no.	Weight [kg]	
123478	0.255	<b>Angle Connector 90x90x65 mm</b>

For various timber connections.

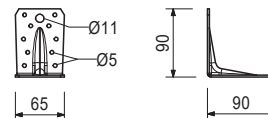

Accessory (not included)

129711	0.010	<b>Wood Screw 6x20 HRK-TX30 HSX</b>
024550	0.005	<b>Wood-Screw 8x20 SK-TX30 HSX</b>

# VGK Bracket System

Art no.	Weight [kg]		L [mm]
<b>Scaff. Tubes 48.3x3.2 mm</b>			
026417	0.000	<b>Cutting Costs Scaffold Tube</b>	1
026411	3.550	<b>Scaff. Tube 48.3x3.2 mm 1 m ga</b>	1000
026412	7.100	<b>Scaff. Tube 48.3x3.2 mm 2 m ga</b>	2000
026413	10.650	<b>Scaff. Tube 48.3x3.2 mm 3 m ga</b>	3000
026414	14.200	<b>Scaff. Tube 48.3x3.2 mm 4 m ga</b>	4000
026419	17.750	<b>Scaff. Tube 48.3x3.2 mm 5 m ga</b>	5000
026418	21.600	<b>Scaff. Tube 48.3x3.2 mm 6 m ga</b>	6000
026415	3.550	<b>Scaff. Tube 48.3x3.2 mm rm ga</b>	1000

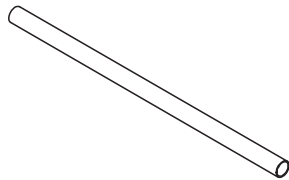

Art no.	Weight [kg]	
102400	1.100	<b>Swivel Coup. EN74 SW38/48 mm ga</b>

For scaffolding tubes Ø48 mm and Ø38 mm.

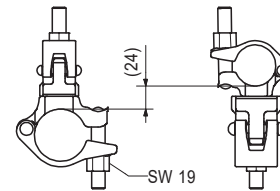
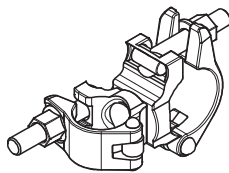

Art no.	Weight [kg]	
017010	1.400	<b>Swivel Coupler SW48/48 mm ga</b>

For scaffolding tubes Ø48 mm.

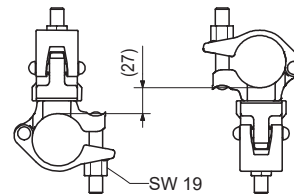
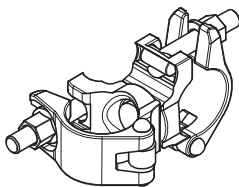

Art no.	Weight [kg]	
124934	1.750	<b>Bracing Connector VGK</b>

For bracing due to longitudinal inclination.

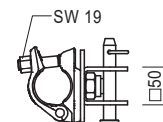
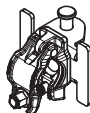

**Consists of**

- 1 pc 710222 Screw ISO 4014-M16x080-8.8-ga
- 1 pc 710229 Hex-Nut ISO 4032-M16-8-ga



# VGK Bracket System

Art no. Weight [kg]

131404 1.080 **Screw-on Coup.-2 HT BØ48 mm M20**

For screwing scaffolding tubes Ø48 mm to components up to 9 mm thick.

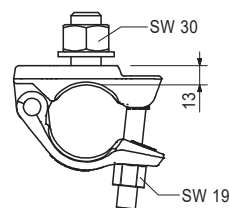
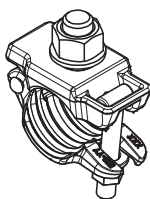

Art no. Weight [kg]

135327 9.570 **Wall Formwork Bracket MX WK**

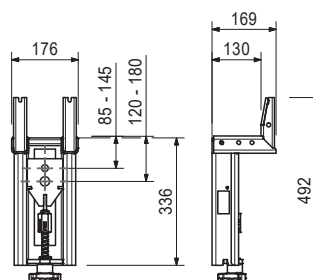
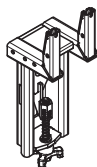

Art no. Weight [kg]

100242 4.570 **Adj. Base Plate UJB 38 mm-80/55**

**Notes**

With captive red quick jack nut.

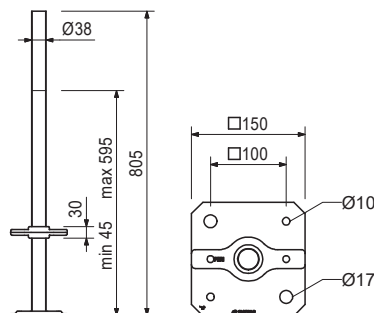
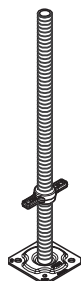

Accessory (not included)

100863 1.020 **Handle Locking UJS**

Art no. Weight [kg]

134174 0.019 **Anchor Lock VGK B15**

For preventing the B15 Anchor VGK from loosening due to vibration.

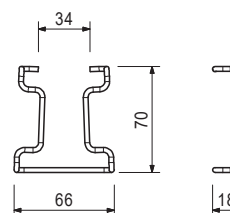
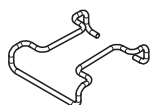

Det optimale systemet for hvert prosjekt og ethvert krav



Veggforskaling



Søyleforskaling



Dekkeforskaling



Klatreforskaling

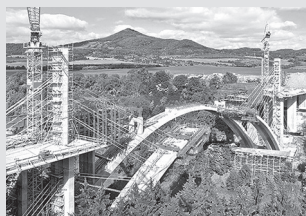

Broforskaling



Tunnelforskaling



Understøttelse



Arbeidsstillas



Fasadestillas



Industristillas



Adkomstløsninger

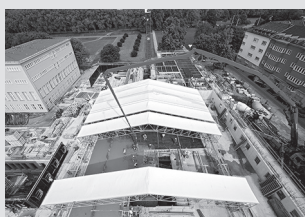

Tak over tak og tildekking



Sikkerhetssystemer

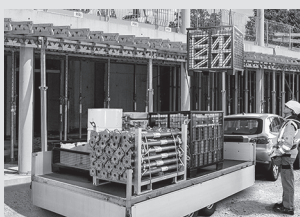

Forbruksartikler



Tjenester



**PERI Norge AS**  
**Forskaling Stillas Engineering**  
 Orhusveien 6  
 3070 Sande i Vestfold  
 Norge  
 Tel. +47 32 20 49 40  
 info@peri.no  
 www.peri.no

