

MULTIFLEX

Girder Slab Formwork

Instructions for Assembly and Use – Standard configuration – Version 2.0

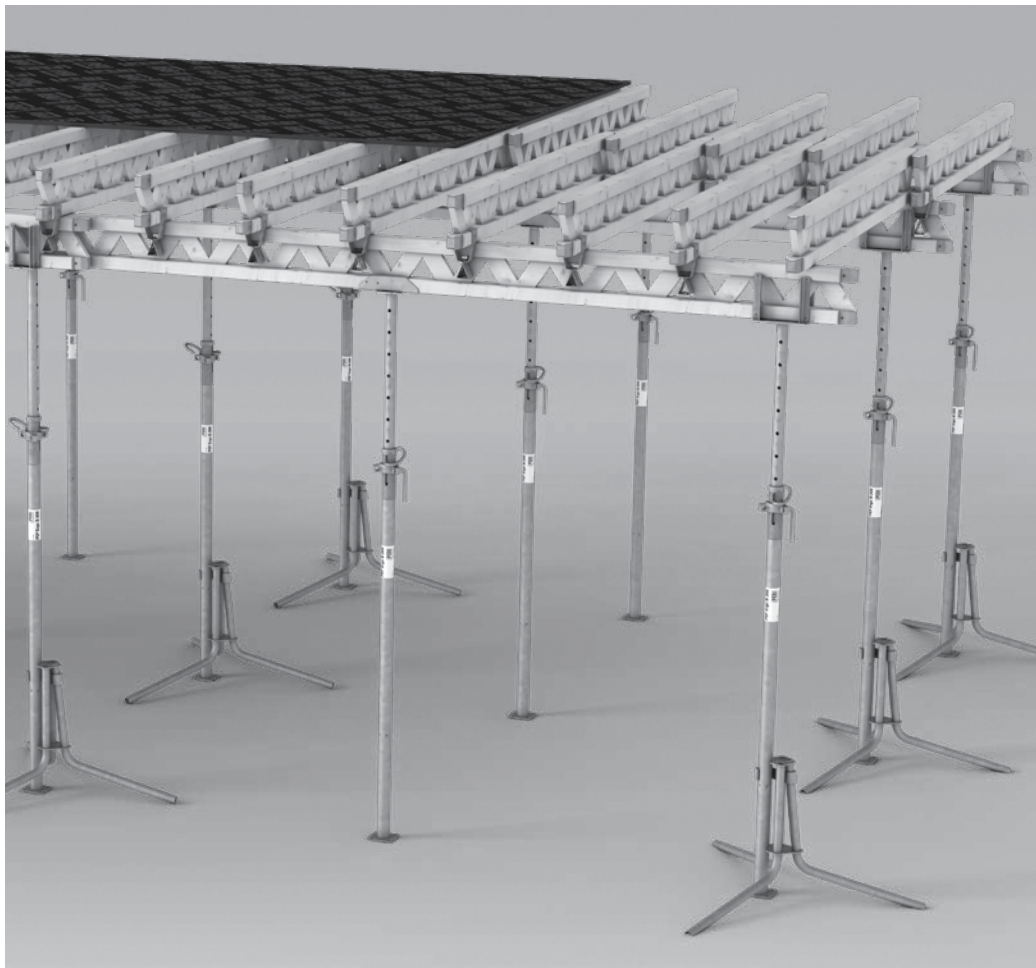

Overview

Main components	4
Key	5

Introduction

Target groups	6
Product description	7
Cleaning and maintenance instructions	8
Additional technical documentation	9
Instructions for Use	9
RFID transponder	9
Disposal	9

Safety instructions

Cross-system	10
System-specific	12
Storage and transportation	13

Assembly and dismantling

A1 Storage and transportation	14
A2 System components	15
Formwork panels	15
Girder GT 24	16
Girder VT 20K and VT 20 Alpha	19
Slab props	20
Formwork supports	20
Assembly aids	21
Shuttering aids	22
A3 Shuttering	24
Shuttering method: Shuttering MULTIFLEX from below	24
Shuttering method: MULTIFLEX with HAMMOCK Safety System	24
Shuttering method: MULTIFLEX with SKY-Anchor Universal (PPE)	25
Formwork assembly	30
A4 Shuttering the cross girder and securing against tipping	31
Shuttering cross girders with the Distance Gauge MF-Plus	31
Fitting the Flexclip, fitting the squared timber connector	32
A5 Guardrails, stop end formwork	34
Guardrails at the slab edge with slab tables	34
Guardrails on concreting section with slab stop end angle	34
Guardrail with Guardrail Holder GT 24 / VT 20 and Guardrail Post HSGP-2 (e.g. on a concreting section)	35
A6 Bracing	36
Bracing VT 20 Girders	36
Bracing and permissible loads for Girder Headpiece GT 24 / VT 20	38
A7 Deshuttering	40

A8 Beams, stop end formwork	43
With Beam Formwork UZ	43
With AW Slab Stopend Angle	43
A9 Application example	46
Overview of edge tables	46
A10 Structural design of slab formwork	48

Tables

Formwork panels	50
GT 24 Girder used as slab beam	52
VT 20 Girder used as slab beam	54
Main beam: 2 x GT 24	56
Main beam: 2 x VT 20	58
Slab Props PEP	60
Slab Props MULTIPROP	70
Beam Formwork UZ	72
AW Slab Stopend Angle	73
Plastic Stopend Angle	74
Slab Stopend Bar 105	75

Program overview

MULTIFLEX Girder Slab Formwork	76
--------------------------------	----



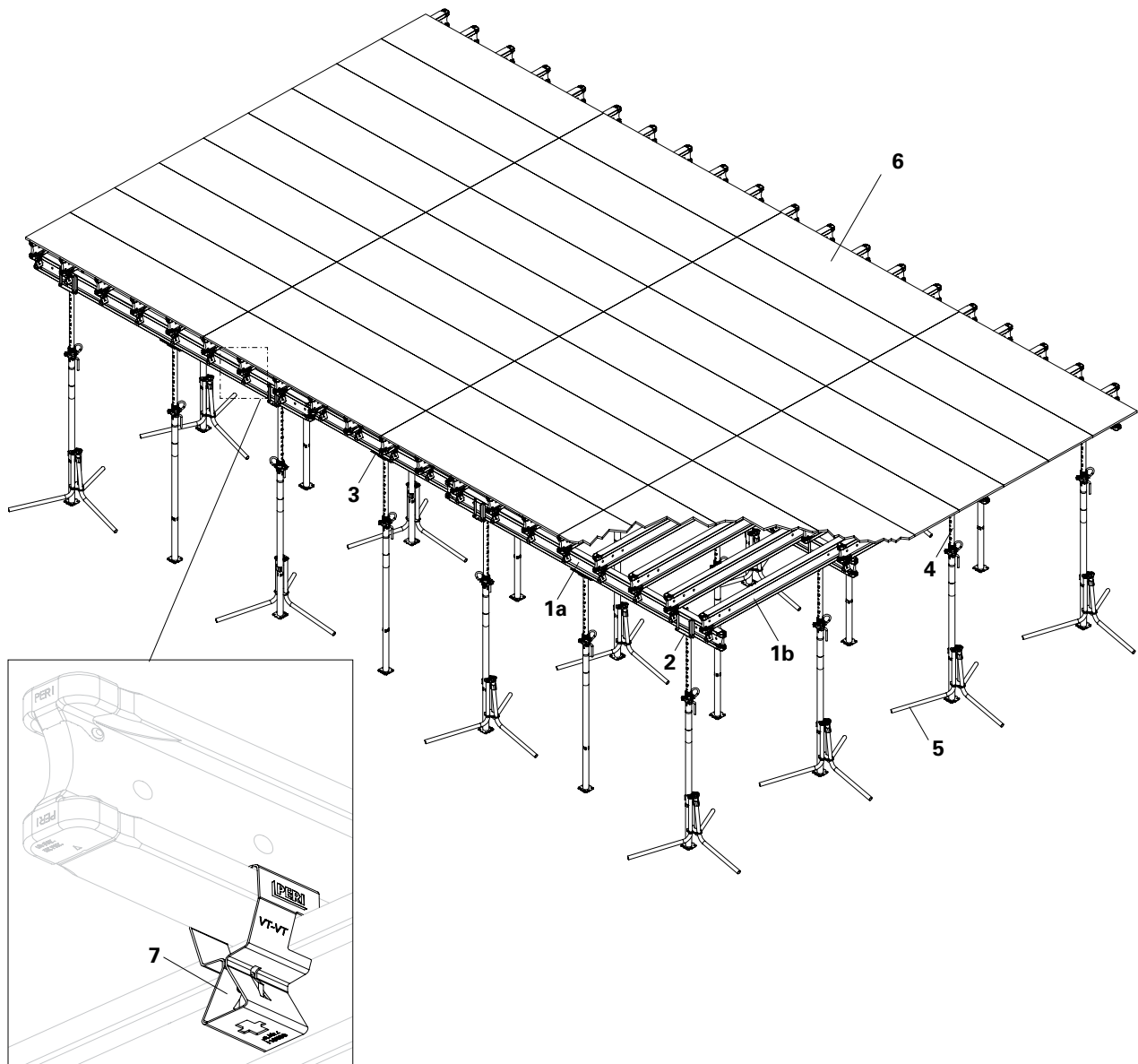









Main components





- | | | | |
|----|--------------|---|----------------|
| 1a | Main beam | 4 | Prop |
| 1b | Cross girder | 5 | Tripod |
| 2 | Crosshead | 6 | Formwork panel |
| 3 | Clawhead | 7 | Flexclip |

Key

Pictogram | Definition

-  Danger/Warning/Caution
-  Note
-  To be complied with
-  Load-bearing point
-  Visual inspection
-  Tip
-  Incorrect use
-  Safety helmet
-  Safety shoes
-  Safety gloves
-  Safety goggles
-  Personal protective equipment to prevent falling from a height (PPE)
-  Observe additional documentation

Arrows

-  Arrow representing an action
-  Arrow representing a reaction of an action*
-  Arrow representing forces

* If not identical to the action arrow.

Safety instruction categories

The safety instructions alert site personnel to the risks involved and provide information on how to avoid these risks. Safety instructions can be found at the beginning of the section or before instructions for action and are highlighted as follows:

Danger

This sign indicates an extremely hazardous situation that could result in death or serious, irreversible injury if the safety instructions are not followed.

Warning

This sign indicates a hazardous situation that could result in death or serious irreversible injury if the safety instructions are not followed.

Caution

This sign indicates a hazardous situation that could result in minor or moderate injury if the safety instructions are not followed.

Note

This sign indicates situations in which failure to observe the information can result in material damage.

Format of the safety instructions

Signal word

Type and source of hazard!
Consequences of non-compliance.
⇒ Preventative measures.

Dimensions

Dimensions are usually given in cm. Other measurement units, e.g. m, are shown in the illustrations.

Conventions

- Instructions are numbered with:
1., 2., 3.
- The result of an instruction is shown by: →
- Position numbers are clearly provided for the individual components and are given in the drawing, e.g. **1**, in the text in brackets, for example **(1)**.
- Multiple position numbers, i.e. alternative components, are represented with a slash: e.g. **1/2**.

Notes on illustrations

The illustration on the front cover of these instructions is understood to be a system representation only. The assembly steps presented in these Instructions for Assembly and Use are shown in the form of examples with only one component size. They are valid for all component sizes contained in the standard configuration.

To facilitate understanding, illustrations are sometimes incomplete. The safety equipment that is not shown in these detailed descriptions must nevertheless be available.

Terminology

Components are not always named in full so that they are easier to read. All components deemed valid according to the program overview may be used. Exceptions are specified.

Example:

- VT 20
- corresponds to:
- VT 20K
- VT 20 Alpha.

Target groups

Contractors

These Instructions for Assembly and Use are designed for contractors who either

- assemble, modify and dismantle PERI systems, or
- use them, e.g. for concreting, or
- allow them to be used for other operations, e.g. carpentry or electrical work.

Safety and Health Protection Coordinator*

- is appointed by the client,
- must identify potential hazards during the planning phase,
- determines measures that provide protection against risks,
- creates a safety and health protection plan,
- coordinates the protective measures for the contractor and site personnel so that they do not endanger each other,
- monitors compliance with the protective measures.

Competent person

- is appointed by the contractor,
- must be on site for all system operations,
- prepares and updates the plan for assembly, modification and dismantling,
- prepares and updates the plan for use of the system by the user,
- supervises the assembly, modification and dismantling work (supervisor).

Competent persons qualified to carry out inspections

Due to the specialist knowledge gained from professional training, professional experience and recent professional activity, the competent person qualified to carry out inspections has a reliable understanding of safety-related issues and can carry out inspections correctly. Depending on the complexity of the inspection to be undertaken, e.g. scope of testing, type of testing or the use of certain measuring devices, a range of specialist knowledge is necessary.

Qualified personnel

PERI systems may only be assembled, modified or dismantled by personnel who are suitably qualified to do so. Qualified personnel must have completed a course of training** in the work to be performed, covering the following points at least:

- Explanation of the plan for the assembly, modification or dismantling of the system in an understandable form and language.
- Description of the measures for safely assembling, modifying or dismantling the system.
- Naming of the preventive measures to be taken to avoid the risk of persons and objects falling.

- Designation of the safety precautions in the event of changing weather conditions that could adversely affect the safety of the system, as well as the personnel concerned.
- Details regarding permissible loads.
- Description of all other risks and dangers associated with assembly, modification or dismantling operations.



- **Ensure that the respective current version of relevant national guidelines and regulations are complied with!**
- **If no country-specific regulations are available, PERI recommends that you proceed according to German guidelines and regulations.**

* Valid in Germany e.g.: Regulations for Occupational Health and Safety on Construction Sites 30 (RAB 30).

** Instructions are given by the contractor themselves or a competent person selected by them.

Product description

Regular assembly

These Instructions for Assembly and Use describe the standard assembly and the intended use of MULTIFLEX Girder Slab Formwork.

The system is a formwork system for creating girder slab formwork. It consists mainly of props, main beams and cross girders as well as formwork panels.

Features

PERI MULTIFLEX is a flexible girder slab formwork system for slab thicknesses up to 1.00 m.

The formwork consists of main beams and cross girders, formwork panels along with crossheads and clawheads.

The following combinations of main beam / cross girder are possible:

VT 20 / VT 20,

GT 24 / VT 20,

GT 24 / GT 24.

Users may select the type of formwork panels required.



- VT 20K: Solid web girder with steel caps at the end of the chord
- VT 20 Alpha: Solid web girder without steel caps at the end of the chord

Wind attack surfaces due to icing are not taken into account.

Snow and ice loads are not taken into account.

Technical data

GT 24 as main beam and cross girder

Slab thicknesses up to 1.00 m

VT 20 as main beam and cross girder

(shown below)

Slab thicknesses up to 0.50 m

GT 24 as main beam

VT 20 as cross girder

Slab thicknesses up to 0.50 m

2 x GT 24 as main beams

1 x GT 24 as cross girder

Slab thicknesses up to 1.00 m

2 x VT 20 as main beams

1 x VT 20 as cross girder

Slab thicknesses up to 1.00 m

For permissible slab thicknesses and available prop loads: see PERI Design Tables.

Intended use

- Use as slab formwork in the form of a temporary building construction for providing a safe working area for the construction, maintenance, repair and demolition of buildings and other structures and the required access for carrying out work. (Extract from DIN EN 12811-1:2004-03)
- Protection of personnel from accidents
- Protection of bystanders (passers-by) from falling objects, dirt, noise.

PERI products have been designed to be used exclusively in industrial and commercial sectors by suitably trained personnel only.

Foreseeable misapplications

- Transportation of persons and loads
- Discharge of loads not permitted by the system.
- Assembly, use and disassembly in an orientation, position or location not specified or shown in the standard assembly.

Cleaning and maintenance instructions

In order to maintain the value and operational readiness of the formwork materials over the long term, clean the panels after each use.

Some repair work may also be inevitable due to the tough working conditions.



The contractor must ensure that the personal protective equipment required for cleaning, maintenance and repair work such as

- Safety helmet,
- Safety shoes,
- Safety gloves,
- Safety goggles,

is available and used as intended.

The following instructions should help to keep cleaning and maintenance costs as low as possible.

Cleaning tools must be adapted to the respective surfaces of the components so that they are not damaged.

Spray the formwork on both sides with concrete release agent before each use; this makes the formwork easier and faster to clean. Spray the concrete release agent very thinly and evenly!

Do not spray work platforms and access routes with concrete release agent.

Slip hazard.

Spray the rear side of the formwork with water immediately after concreting; this avoids any time-consuming and costly cleaning operations.

When used continuously, spray the formlining elements with concrete release agent immediately after deshuttering; then clean by means of a scraper, brush or rubber lip scraper. Important: do not clean formlining made of plywood with high-pressure equipment. This could result in the formlining being damaged.

Fix recesses and built-in parts with double-head nails; as a result, the nails can easily be removed later, and damage to the formlining is largely avoided.

Close all unused tie holes with plugs; this eliminates any subsequent cleaning or repair work.

Tie holes accidentally blocked with concrete are cleared by means of a steel pin from the formlining side.

When placing bundles of reinforcement bars or other heavy objects on horizontally supported formwork elements, suitable support, e.g. squared timbers, is to be used: this prevents impressions and damage to the formlining to a large extent.

Internal concrete vibrators should be fitted with rubber caps if possible; as a result, any damage to the formlining is reduced if the internal vibrator is accidentally inserted between the reinforcement and formlining.

Never clean powder-coated components, e.g. elements and accessories, with a steel brush or hard metal scraper; this ensures that the powder coating remains intact.

Use spacers for reinforcement with large-sized supports or extensive areas of support; this largely avoids impressions being formed in the formlining when under load.

Mechanical components, e.g. spindles or gear mechanisms, must be cleaned of dirt or concrete residue before and after use, and then greased with a suitable lubricant.

Provide suitable support for the components during cleaning so that no unintentional change in their position is possible.

Do not clean components suspended on crane lifting gear.

Additional technical documentation

- Instructions for Assembly and Use:
 - PEP Ergo, PEP
 - MULTIPROP MP
 - MULTIPROP system
 - VARIODECK
 - Application note for the PERI UP Flex Mobile Working Platform
- Instructions for Use:
 - Pallets and stacking devices
 - Stripping Cart ASW 465
 - Aluminium stripping cart
 - Pallet lifting truck
 - Hammock safety system
 - Sky-Anchor Universal
- Data sheet:
 - GT 24 Girder user information
 - VT 20K-2 and VT 20-2 Girder user information
 - Tie Bolt 14/20 x 130
- MULTIFLEX brochure

Instructions for Use

Use in a way not intended, deviating from the standard configuration or the intended use according to the Instructions for Assembly and Use, represents a misapplication with a potential safety risk, e.g. risk of falling.

Only PERI original components may be used. The use of other products and spare parts is not allowed and represents a misapplication with associated safety risks.

Changes to PERI components are not permitted.

The system described in these Instructions for Assembly and Use may contain patent-protected components.

RFID transponder

Individual components are equipped with an RFID transponder. RFID transponders combine hardware with additional software to create a smart product.

Depending on the component and digital solution, you can:

- Call up technical documents.
- View maintenance plans.
- Track information on transport and logistics.



For more information, see “RFID LA-TAG Assembly Set User Information”.

Disposal

Carry out disposal in accordance with the relevant national regulations.

Observe the safety data sheets of the auxiliary and operating materials.

Cross-system



Safety instructions apply to all service life phases of the system.

General information

The contractor must ensure that the Instructions for Assembly and Use supplied by PERI are available at all times and understood by the site personnel.

These Instructions for Assembly and Use can be used as the basis for creating a risk assessment. The risk assessment is compiled by the contractor. The Instructions for Assembly and Use are not a substitute for a risk assessment!

Observe and comply with the safety instructions and permissible loads.

For the application and inspection of PERI products, observe the current laws and regulations in force in the respective countries.

Materials and working areas are to be inspected before each use and assembly for:

- damage,
- stability and
- functional correctness.

Damaged components must be exchanged immediately on site and no longer used.

Safety components are to be removed only when they are no longer required.

When on slab formwork, scaffolds and working platforms:

- do not jump,
- do not run,
- do not drop anything from or onto it.

Components provided by the contractor must comply with the characteristics stipulated in these Instructions for Assembly and Use and all applicable laws and standards. Unless otherwise indicated, the following applies in particular:

- Timber components:
Strength class C24 for solid wood according to DIN EN 338:2016-07.
- Scaffolding tubes:
Galvanised steel tubes with minimum dimension \varnothing 48.3 x 3.2 mm according to DIN EN 12811-1:2004-03 4.2.1.2.
- Scaffolding tube couplings:
according to DIN EN 74-1:2022-09 and DIN EN 74-2:2022-09.

Deviations from the standard configuration are only permitted after a further risk assessment has been carried out by the contractor.

Appropriate measures for working and operational safety, as well as stability, are defined on the basis of this risk assessment.

Corresponding proof of stability can be provided by PERI on request if the risk assessment and resulting measures to be implemented are made available.

Nails and wood screws must not protrude. Only allow other connecting components to protrude to the extent that is necessary. If necessary, mark protruding components or fit them with protective material.

Secure all bolts with cotter pins and all screws with nuts

Before and after extraordinary events that may have damaging effects on the safety of the system, the contractor must immediately

- produce another risk assessment, the results of which must be used to implement suitable measures to ensure the stability of the system,
- arrange for an extraordinary inspection to be carried out by a competent person qualified to do so. The aim of this inspection is to detect and repair damage in good time in order to ensure safe use of the system.

Exceptional events could be:

- accidents, fire, explosions, collisions,
- long periods of non-use,
- natural events, e.g. heavy rainfall, heavy snowfall, significant icing, storms or earthquakes.

Suitable measures could be:

- removing nets/tarpaulin,
- clearing snow and ice,
- reducing live loads,
- securing loose materials.

Assembly, modification and dismantling work

PERI systems may only be assembled, modified or dismantled under the supervision of a person qualified to do so and by technically suitable employees. The qualified personnel must have received appropriate training for the work to be carried out with regard to specific risks and dangers.

On the basis of the risk assessment and the Instructions for Assembly and Use, the contractor must create installation instructions to guarantee safe assembly, modification and dismantling of the formwork system.



The contractor must ensure that the personal protective equipment required for the assembly, modification or dismantling of the system, e.g.

- Safety helmet,
- Safety shoes,
- Safety gloves,
- Safety goggles,

is available and used as intended.

For work at a higher level, use an approved ladder or platform system, or an assembly scaffold.



If personal protective equipment against falling from a height (PPE) is required or specified in local regulations, the contractor must determine appropriate attachment points on the basis of the risk assessment.

The PPE to be used to prevent falling is determined by the contractor.

The contractor must

- provide safe working areas for site personnel, which are to be reached through the provision of safe access ways, cordon off and clearly mark danger zones.
- guarantee stability during all stages of construction, in particular during assembly, modification and dismantling operations.
- ensure and demonstrate that all loads that occur are safely transferred.
- develop a rescue concept.
- ensure that skilled workers receive instruction.

Use

Every contractor who uses or allows the PERI systems to be used, is responsible for ensuring that the equipment is in good condition.

If the system is used successively or at the same time by several contractors, the health and safety coordinator must point out any possible mutual hazards and all work must then be coordinated.

When systems are used in publicly accessible areas,

- measures to prevent unauthorised use, e.g. enclosure of access areas, must be taken.
- Measures are taken against injuries caused by bumping against protruding components, e.g. assembly of protective components.

Always keep the contact surfaces of the system free of dirt, objects, snow and ice.

Close off the system in extreme weather conditions.

System-specific

Strike components only when the concrete has sufficiently hardened and the person in charge has given the go-ahead for deshuttering to take place.

Anchoring is to take place only if the anchorage has sufficient concrete strength.

The load-distributing support used, such as planking, must match the respective substrate used. If several layers are required, planks are to be arranged crosswise.

During deshuttering, do not tear off the formwork units with the crane.

The prevailing prop loads (see Design Tables) must be safely transferred by slab props or tower systems with a sufficient load-bearing capacity.

When storing heavy items on the formwork, the load-bearing capacity must be taken into consideration.

Cantilevers may only be accessed once the bracing and fall protection measures have been installed.

The horizontal fixed position of the slab formwork must be guaranteed. This is ensured by circumferential walls and pre-concreted beams. Otherwise, transfer of the horizontal loads has to be guaranteed by means of other measures provided by the contractor, for example bracing. Load assumptions for horizontal loads in accordance with DIN EN 12812.

Inspection of the anchoring and associated components must be carried out by the contractor (user).

Enclosure of the platforms or mounting of additional surface areas is not permissible because wind load calculations will be affected.

The platforms are to be inspected for damage at regular intervals by authorised and competent personnel.

Dirt that affects functionality is to be removed immediately.

When stepping onto platforms, watch out for hazards and use PPE if necessary.

When working at open edges of the building, such as when moving the platforms, site personnel must always be secured against falling, e.g. with PPE. Cordon off danger zones.

In order to avoid overloading the integrated auxiliary props, the load-bearing capacity of the slabs, plates and beams that have already been completed must be activated. For this, free deflection capability is required for these components.

This is done by releasing and reattaching all existing auxiliary props and is also required for formwork systems in which the prop head is part of the slab formwork.

For supporting pre-cast slabs, details provided by the manufacturer are also to be taken into consideration.

In the case of unfavourable structure geometries or greater wind speeds, additional securing measures are to be implemented, e.g.:

- ballast,
- bracing,
- dismantling the formwork etc.

Safety systems for MULTIFLEX:

- Fall protection in the form of a safety net, HAMMOCK safety system in combination with formwork for MULTIFLEX systems,
- Fall protection as a mobile attachment point (PPE) as individual protection for safe shuttering

Site personnel, construction materials or tools must not be transported with the crane during relocation operations. Exceptions to this can be determined through the operational working and assembly instructions on the basis of a corresponding risk assessment carried out by the contractor.

When operating lifting equipment near the platforms there is the risk of accidental detachment of the load.

This risk is to be taken into consideration when creating the site-specific work and assembly instructions.

Storage and transportation

General information

- Store and transport components in such a way that no unintentional change in their position is possible. Detach load-lifting accessories and lifting gear from the lowered components only if they are in a stable position and no unintentional change is possible.
- Do not drop the components.
- Only ever use approved and inspected means of transportation from PERI including lashing, lifting gear and slings.
- Only ever attach the means of transport to the intended attachment points with a positive fit using suitable lifting gear and slings.

During the relocation procedure

- Ensure that components are picked up and set down in such a way that unintentional falling over, falling apart, sliding, falling down or rolling is avoided.
- Always use ropes to guide components or assemblies that are susceptible to wind when moving them with a crane.
- No one is allowed to remain under the suspended load.
- The access areas on the construction site must be free of obstacles and tripping hazards, and must also be slip-resistant.
- For transportation, the substrate must have sufficient load-bearing capacity.
- Use original PERI storage and transport systems, e.g. crate pallets, pallets or stacking devices.

! NOTE

Incorrectly stored or transported components can get damaged. Damaged components are no longer safe and may no longer be used.

- Operating instructions for PERI pallets and stacking devices must be taken into consideration!
- Manually-created transportation units must be stacked and secured correctly!
- Pallets and stacked components are to be protected against the effects of the weather, e.g. secure elements against lifting by means of tension belts!
- Always attach the four-sling lifting gear using the four load-bearing points.

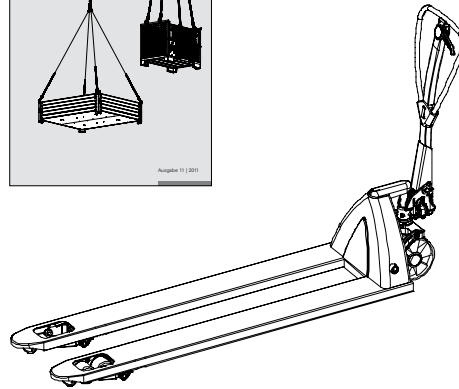

Transporting loads

PERI pallets and stacking devices are suitable for lifting by crane or forklift. They can also be moved with the PERI pallet lifting trolley.

- Always attach the four-sling lifting gear using the four load-bearing points.
- Only one pallet is moved at any one time with the crane.

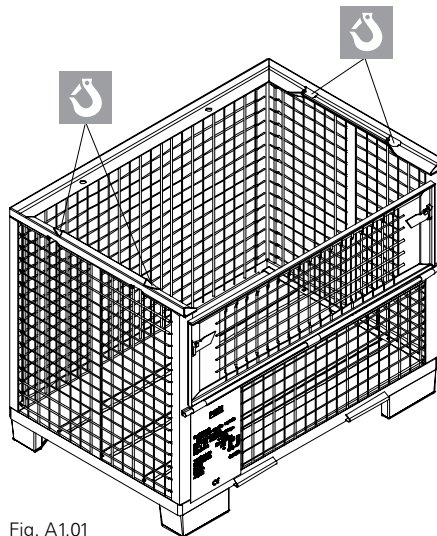

Fig. A1.01



Lashing straps are manufactured according to DIN EN 12195-2, and are to be regularly checked in accordance with this standard.

The following are just some examples. (Fig. A1.01 – A1.02a)

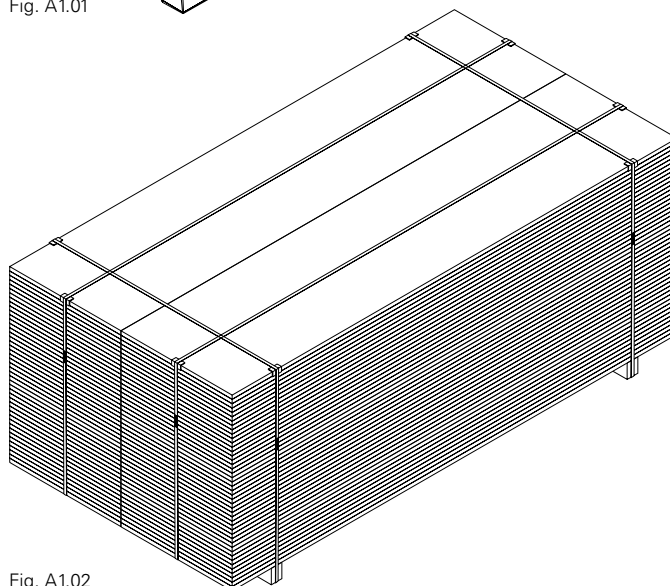

Fig. A1.02

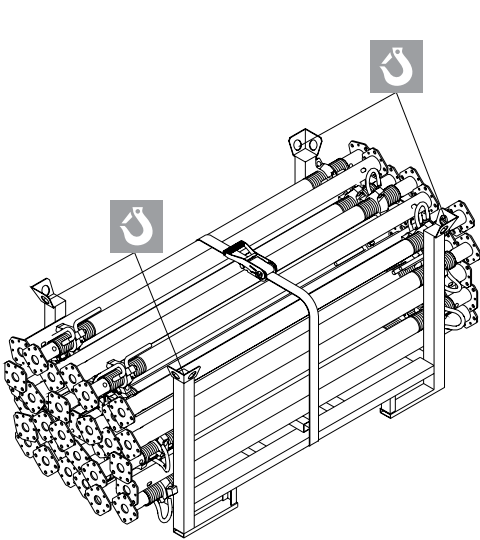

Fig. A1.02a

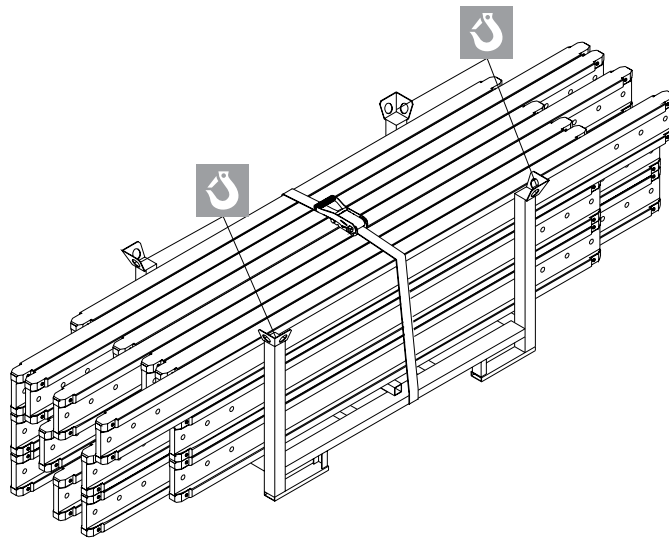

Fig. A1.02b

A2 System components

Formwork panels

For other formwork panels, see the PERI product range.

The 3-S panel, 21 mm, is taken into account in the PERI Design Tables.

(Fig. A2.01)

The use of other formwork panels must be assessed statically.

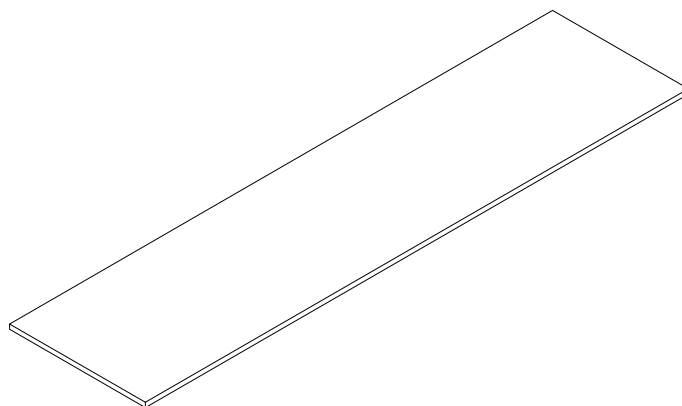

Fig. A2.01

Girder GT 24

Permissible internal forces and support forces

Permissible shear force	perm. Q = 13.0 kN
Permissible support force in the node (+/- 2 cm)	perm. A _n = 28.0 kN
Permissible support force between the nodes	perm. A _m = 20.0 kN
Permissible bending moment	perm. M = 7.0 kNm
Permissible support moment (support in node)	perm. M _n = 7.0 kNm
Permissible support moment (support between the nodes)	perm. M _m = 4.0 kNm
Bending stiffness	EI = 887 kNm ²

End supports for single-span and continuous girders

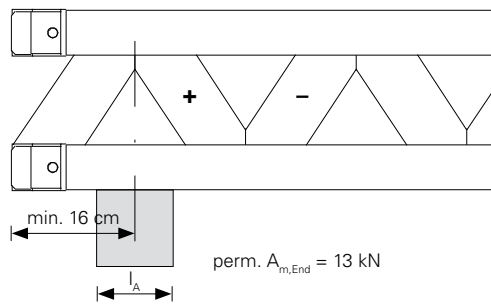
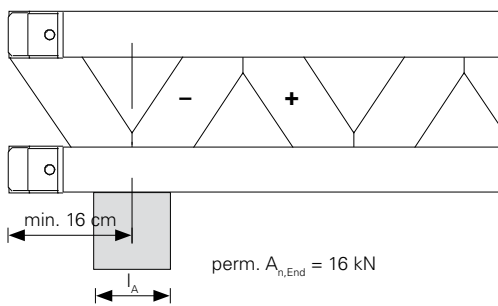

Supports for continuous and cantilever beams

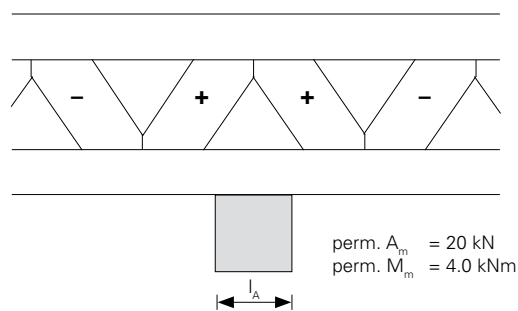
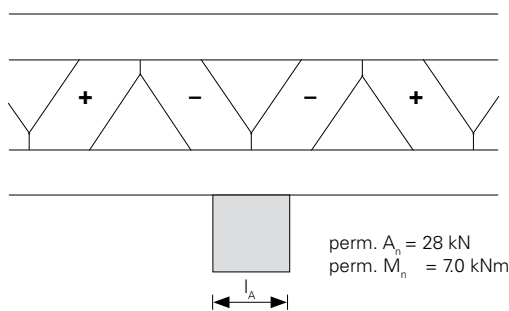

To introduce the maximum support force into the Girder GT 24, the support lengths l_A must have the following minimum dimensions:

- 13.5 cm for support directly under the nodes,
- 14.5 cm for support directly between the nodes.

Girder GT 24 with clawhead

Permissible support force between the nodes

perm. Am = 27.1 kN

For the intermediate support of formwork girders:

Attach intermediate supports to the Girder GT 24 with clawhead. Adjust length of props accordingly

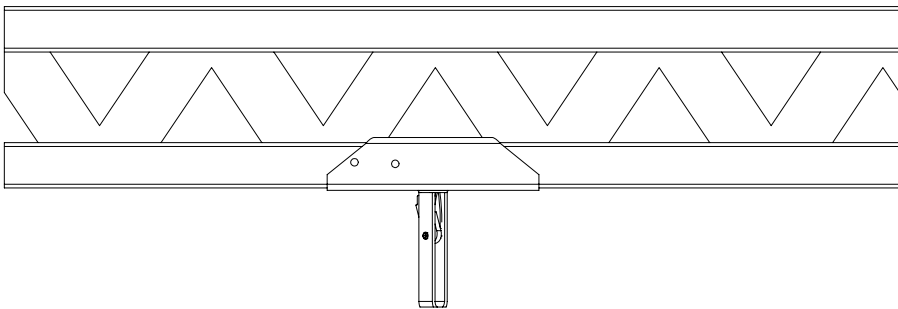

Girder GT 24

Bearing pressure:

Support force perm. $A = w \times L_{\text{eff}} \times k_c \times \text{perm. } \sigma_{D\perp}$

w = support width

L_{eff} = effective support length

= $L_A + 2 \times 3 \text{ cm}$, but $\leq 2 \times L_A$

Design-typical shear pressure coefficient for

Support directly under the nodes $k_{c,90,n} = 1.45$

Support between the nodes $k_{c,90,m} = 1.0$

Bearing pressure perm. $\sigma_{D\perp} = 1.24 \text{ N/mm}^2$

Specified shear forces

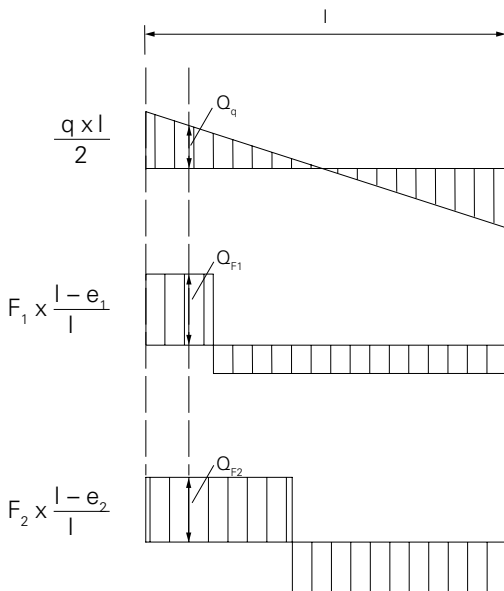
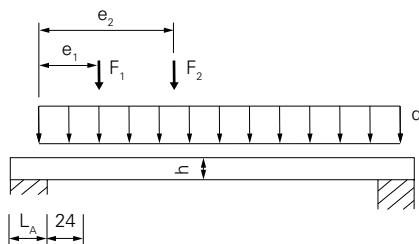

For the structural design, the shear forces (external loads) may be reduced as follows:

$$Q_{q,\text{red}} = \frac{q \times l}{2} \times \left(1 - \frac{L_A}{l} - \frac{48 \text{ cm}}{l}\right)$$

$$e_1 < 60 \text{ cm: } Q_{F1,\text{red}} = F_1 \times \frac{l - e_1}{l} \times \frac{e_1}{60 \text{ cm}}$$

$$e_2 > 60 \text{ cm: } Q_{F2} = F_2 \times \frac{l - e_1}{l}$$

$$Q_{\text{red}} = Q_{q,\text{red}} + Q_{F1,\text{red}} + Q_{F2}$$

$$Q_{\text{red}} \leq \text{perm. } Q = 13 \text{ kN}$$

In addition, the shear force

$$Q = Q_q + Q_{F1} + Q_{F2}$$

must be verified directly over the support.

$$Q \leq \text{perm. } Q_n = 16 \text{ kN}$$

The following applies to cantilever beams:

$$l = 2 \times l_k$$

Girder VT 20K and VT 20 Alpha

Permissible internal forces and support forces:

Permissible shear force
perm. Q = 11.0 kN
Permissible support force
perm. A = 22.0 kN
Permissible bending moment
perm. M = 5.0 kNm

Bending stiffness
EI = 460 kNm²

End supports for single-span and continuous girders

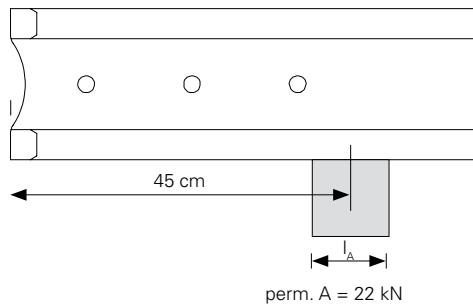
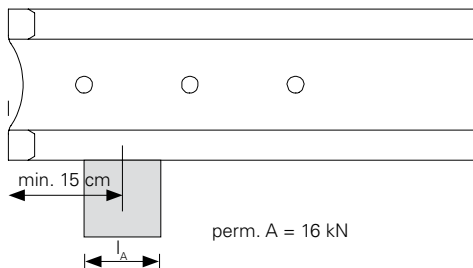

The projecting length of the girder must be at least 15 cm.

Depending on the projecting length of the girder between the two values A = 16 kN and max. perm. A = 22 kN, the permissible support load can be linearly interpolated.

To introduce the maximum support force into the Girder VT 20, the support length l_A must be at least 13.5 cm.

Bearing pressure:

Support force perm. A = w x L_{eff} x k_c x perm. $\sigma_{D\perp}$

w = support width

L_{eff} = effective support length

= $L_A + 2 \times 3$ cm, but $\leq 2 \times L_A$

Design-typical shear pressure coefficient for $k_{c,90,n} = 1.15$

Support pressure perm. $\sigma_{D\perp} = 1.24$ N/mm²

Specified shear forces

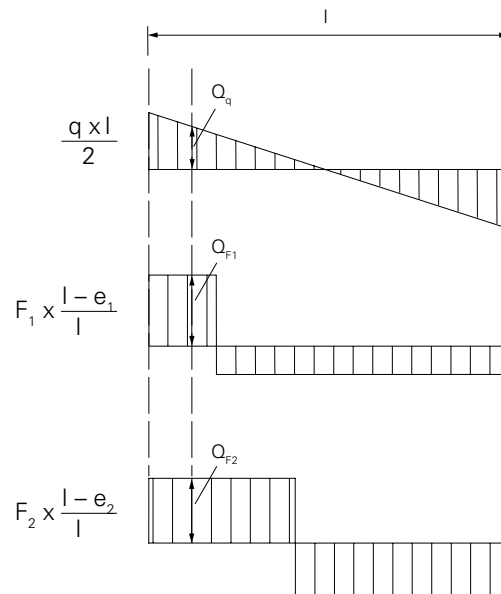
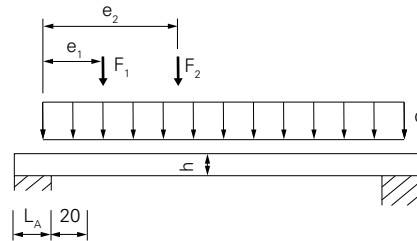

For the structural design, the shear forces (external loads) may be reduced as follows:

$$Q_{q,red} = \frac{q \times l}{2} \times \left(1 - \frac{L_A}{l} - \frac{40 \text{ cm}}{l}\right)$$

$$e_1 < 50 \text{ cm: } Q_{F1,red} = F_1 \times \frac{l - e_1}{l} \times \frac{e_1}{50 \text{ cm}}$$

$$e_2 > 50 \text{ cm: } Q_{F2} = F_2 \times \frac{l - e_1}{l}$$

$$Q_{red} = Q_{q,red} + Q_{F1,red} + Q_{F2}$$

$$Q_{red} \leq \text{perm. } Q = 11 \text{ kN}$$

In addition, the shear force

$$Q = Q_q + Q_{F1} + Q_{F2}$$

must be verified directly over the support.

$$Q \leq \text{perm. } Q_n = 16 \text{ kN}$$

The following applies to cantilever beams: $l = 2 \times l_k$

Slab props



DANGER

Excessive load on the MULTIFLEX slab formwork!

Danger to life due to collapse of the slab formwork and the concrete slab!

- Loads from the MULTIFLEX slab formwork must be safely transferred into the substrate.
- Do not exceed the permissible load-bearing capacities!

PERI Shoring

- Steel Tube Props PEP (4a).
- Aluminium Props MULTIPROP MP (4b).
- Shoring towers of the MULTIPROP System, PERI UP Flex, PD 8, ST 100 (not shown).

See corresponding Instructions for Assembly and Use.

- Depending on the available head versions, select the following:
 - For heads with a self-locking coupling, engage the self-locking coupling and check functionality.
 - For heads without a self-locking coupling, secure by means of bolts and cotter pins.

- Set up the prop. (Fig. A2.03)

Release:

Release the self-locking coupling or loosen bolt and remove head.

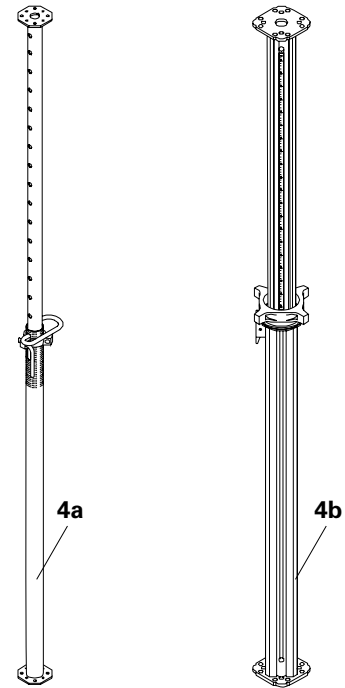

Fig. A2.01

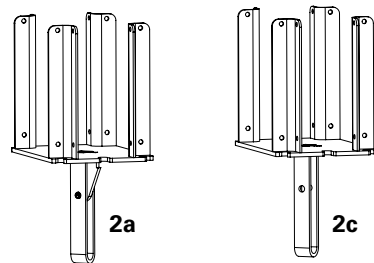

Fig. A2.02a

Formwork supports

For providing stable support for one or two formwork girders and as intermediate support.

At the end of the girder or at the girder joint.

- Crosshead 20/24S (2a) with self-locking coupling.
- Crosshead 20/24 (2c) with bolts and cotter pins.
- Lowering Head 20/24 (2b) with bolts and cotter pins.

(Fig. A2.02a and Fig. A2.02b)

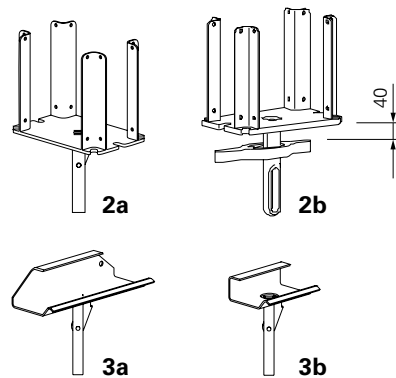

Fig. A2.02b



When staking out the prop, pay attention to the required lowering distance (min. 40 mm).

For intermediate support

- Clawhead 24S with self-locking coupling (3a).
- Clawhead 16/20S with self-locking coupling (3b).

(Fig. A2.02b)



The formwork supports fit all standard slab props with 40 mm hole diameters.

Assembly:

- Place head on the prop.

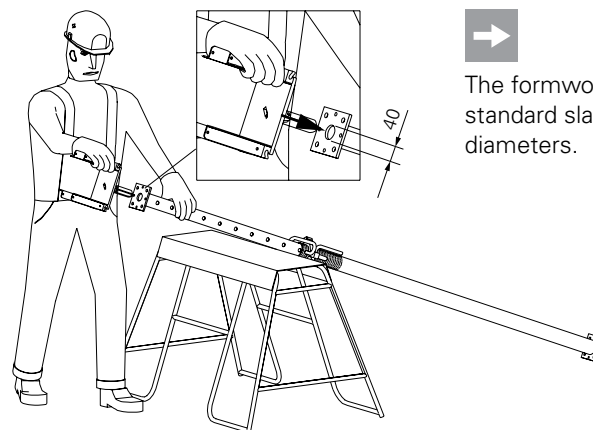

Fig. A2.03

Assembly aids

Universal tripod

For slab props \varnothing 57 – □ 120 mm.
(Fig. A2.04a)

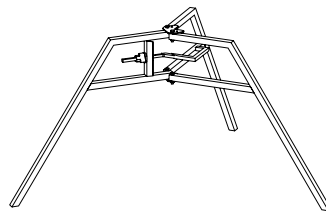
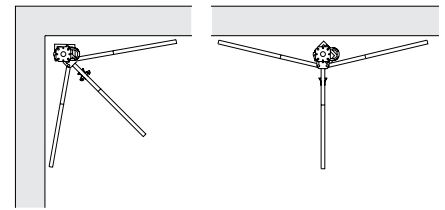

Fig. A2.04a



Tripod PEP Ergo

For slab props \varnothing 44 – □ 64 mm.
(Fig. A2.04b)

Due to the swivel foot design, they can also be positioned in corners or against straight walls.

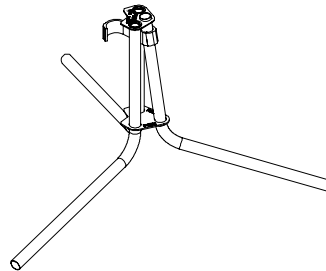

Fig. A2.04b

Brace clamp

For fitting the diagonal bracing with boards.

– For slab props \varnothing 48 – 76 mm.
(Fig. A2.05a)

– For slab props \varnothing 76 – 89 mm
and 100 mm x 100 mm
up to 120 mm x 120 mm.
(Fig. A2.05b)

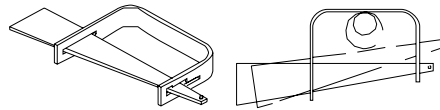

Fig. A2.05a

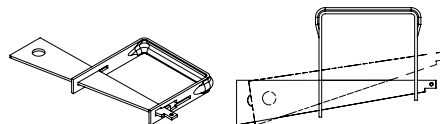

Fig. A2.05b

MULTIPROP Frame MRK

For bracing PERI MULTIPROP props.
(Fig. A2.06)

PEP Frame PRK

For bracing PERI PEP props.
(Fig. A2.07)

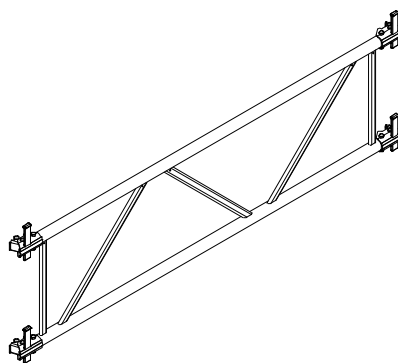

Fig. A2.06

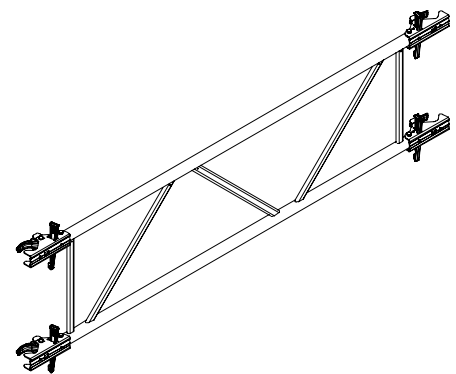

Fig. A2.07

Shuttering aids

Installation bar

For installing and removing the girders.

For GT 24 and VT 20

Installation bar GT / VT. (Fig. A2.08)

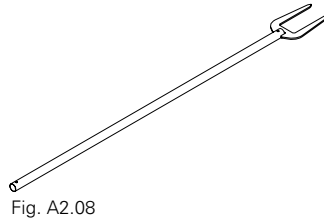

For Girder GT 24

Installation bar 24. (Fig. A2.09)

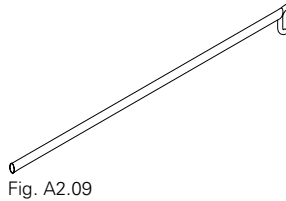

Distance Gauge MF-Plus

For fitting and aligning formwork girders for the MULTIFLEX System as well as assembling the Flexclips, see A4. (Fig. A2.10)

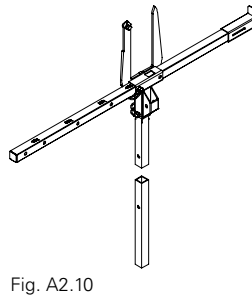

STRIKING HAMMER SXP SH

The Striking Hammer SXP SH can be used to loosen the wedge of a lowering head from a safe contact area. (Fig. A2.11)

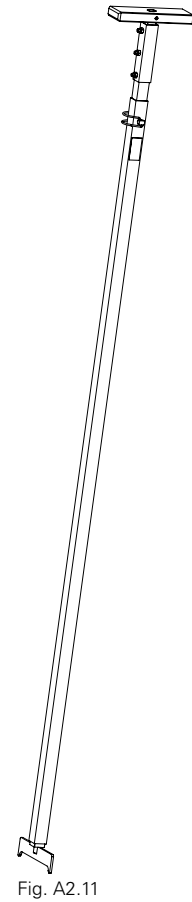

A2 System components

Formwork carriage

PERI Stripping Cart ASW 465
(Fig. A2.12) or
Stripping Cart Alu (not shown).

PERI UP Flex Mobile Scaffold

Variable positionable work platform,
available in heights of 1.0 m and 1.5 m
(Fig. A2.13)

PERI UP Flex Mobile Working Platform

Variable positionable work platform
for easy access, available in heights
of 0.75 m and 1.0 m.
(Fig. A2.14v)

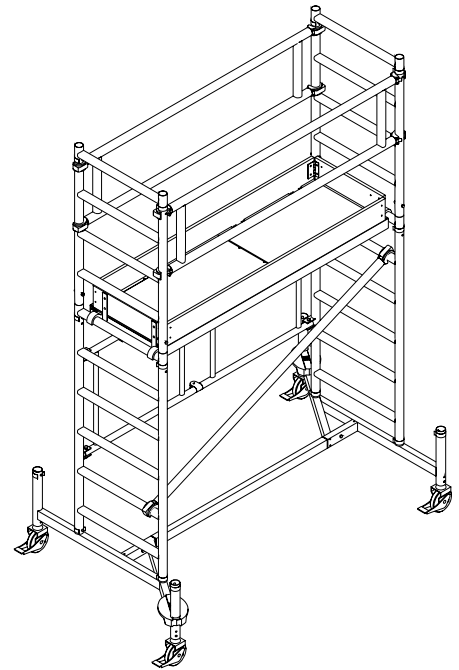

Fig. A2.12

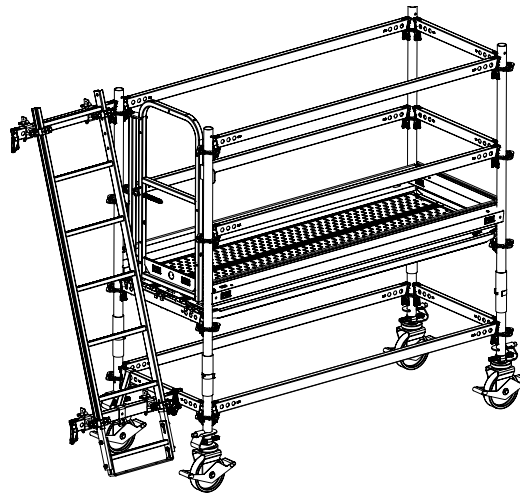

Fig. A2.13

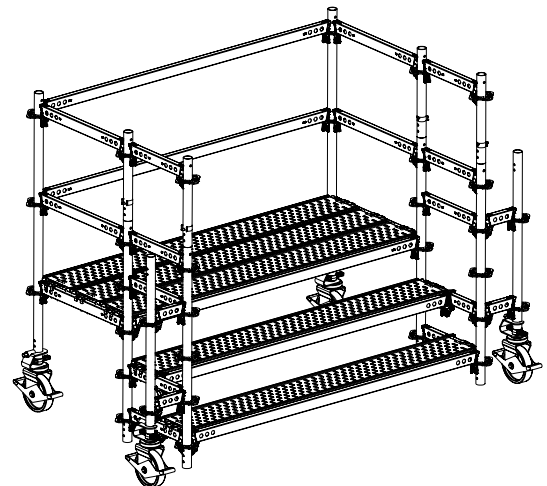

Fig. A2.14

! NOTE

The current applicable standards and regulations must be observed when using MULTIFLEX Slab Formwork.

Shuttering method: Shuttering MULTIFLEX from below

Shuttering the main beams and cross girders as well as laying and nailing the formlining of the MULTIFLEX Girder Slab Formwork from a secured standing position from below or using suitable aids that enable assembly from below (e.g. facade scaffold, mobile scaffold, mobile working platform, cherry picker). With this safety measure, there is no risk of falling. The cross girders can be installed with a cross girder spacing that is selected according to the structural requirements.

Shuttering method: MULTIFLEX with HAMMOCK Safety System

Securing the slab surface to be shuttered with the HAMMOCK Safety System. With this technical safety measure, the cross girders and formwork panels of the Multiflex Girder Slab Formwork can be safely installed from above with a cross girder spacing that is selected according to the structural requirements. The main beam and HAMMOCK Safety System are mounted from below.



HAMMOCK Safety System – Original operating instructions:

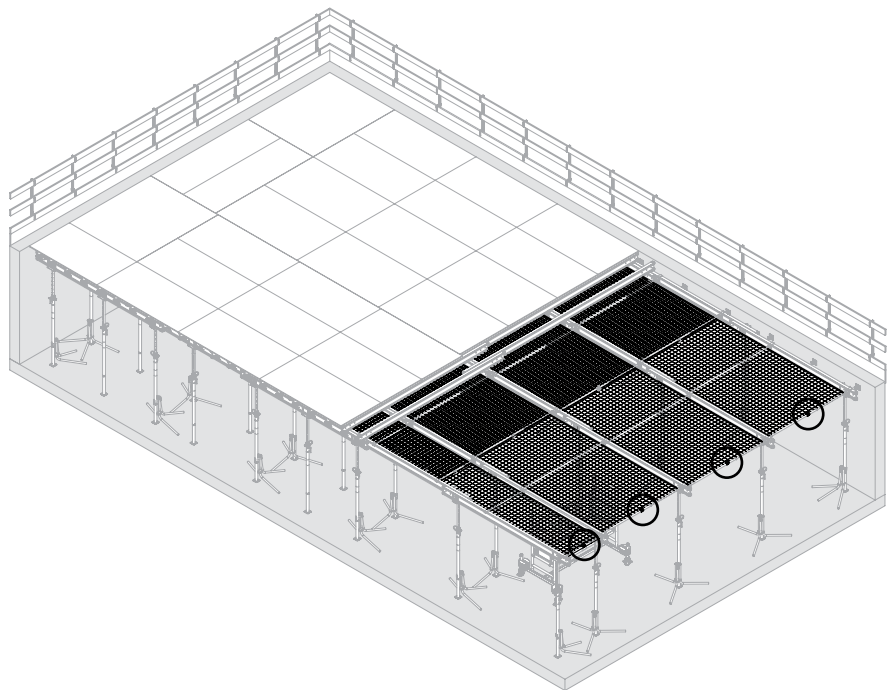

Fig. A3.01

Shuttering method: MULTIFLEX with SKY-Anchor Universal (PPE)

Use this method if, according to the contractor's risk assessment, the previous options for safe shuttering cannot be implemented.

For work-related reasons or at interference points, such as around columns, beams, support openings, floor recesses or overhead work at great clear heights, shuttering from above may be more suitable.

For ergonomic reasons, these systems can only be used for certain ceiling height ranges.

In the case of small interference points (e.g. support openings through the area to be shuttered):

Securely shutter the main beams and cross girders including formwork panels using one of the safe methods mentioned above. To install the formwork panels near interference points > 30 cm in the slab surface, place the SKY-Anchor Universal on the slab surface as a mobile attachment point and use in conjunction with PPE.

In the case of large interference points (floor recesses, unpaved substrates, "forest of props"):

Securely shutter the main beams and cross girders as well as formwork panels until a sufficient area is available for proper placement of the SKY-Anchor Universal as specified in the Instructions for Assembly and Use. Then place the SKY-Anchor Universal on the formwork and secure the formwork from above using PPE.



Sky-Anchor Universal - Translation of Original Instructions for Use:

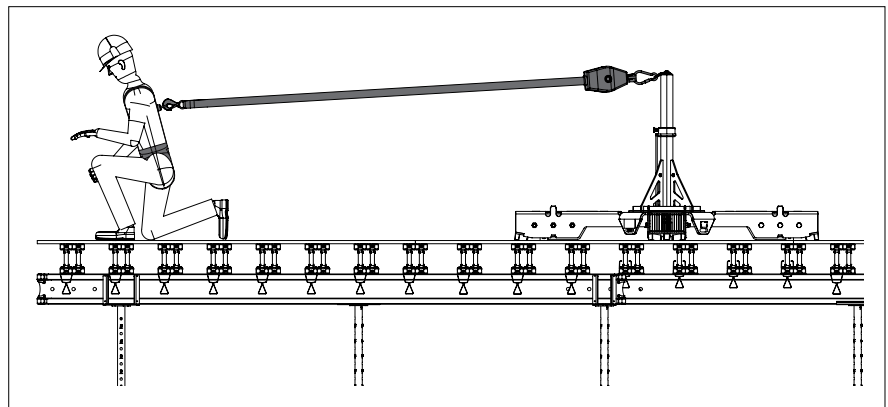
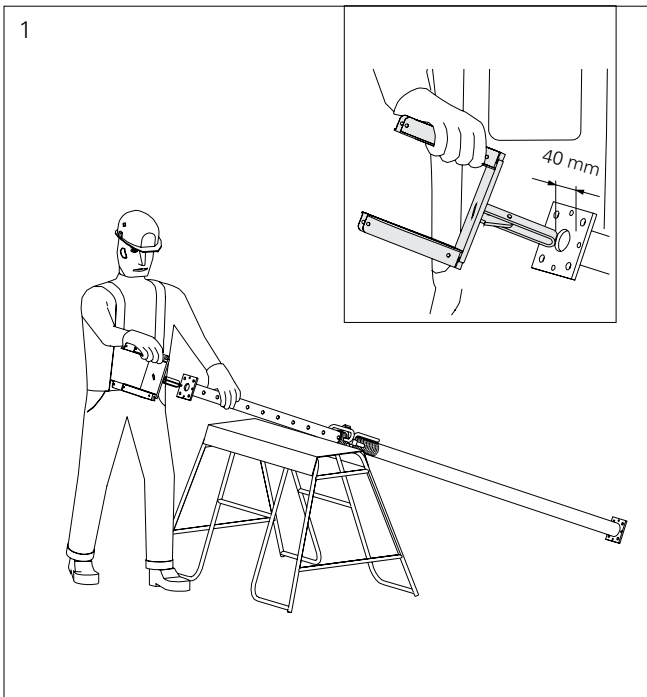

Fig. A3.02



Mount the crosshead or clawhead on the prop and lock in place (in the case of self-locking coupling).
In all the other cases, secure with bolts and cotter pins.

Alternative to crosshead:

Lowering Head 20/24 for a straightforward lowering process.

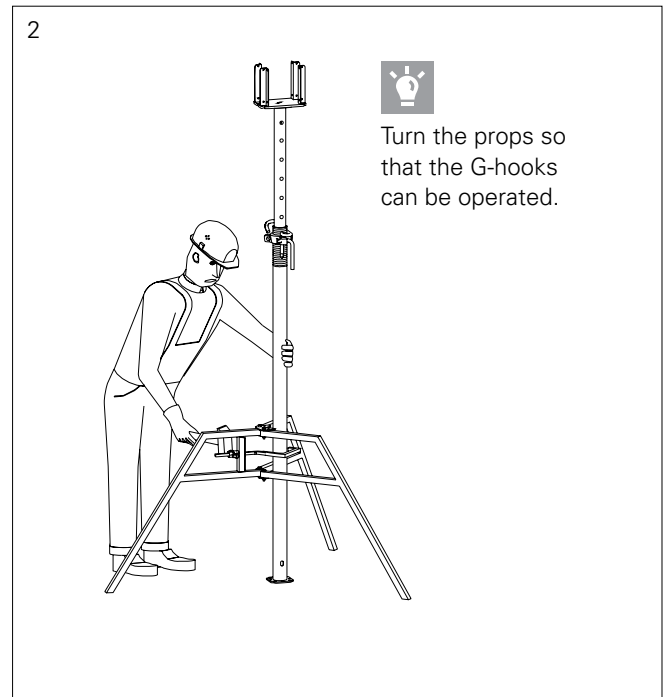

Position crosshead props on a flat, clean and sufficiently load-bearing substrate. Secure with tripod (assembly aid).



For inclined use, separate proof of stability is required!
With tripod:

Horizontal loads from the shuttering procedure can only be transferred for formwork heights up to approx. 3.0 m.

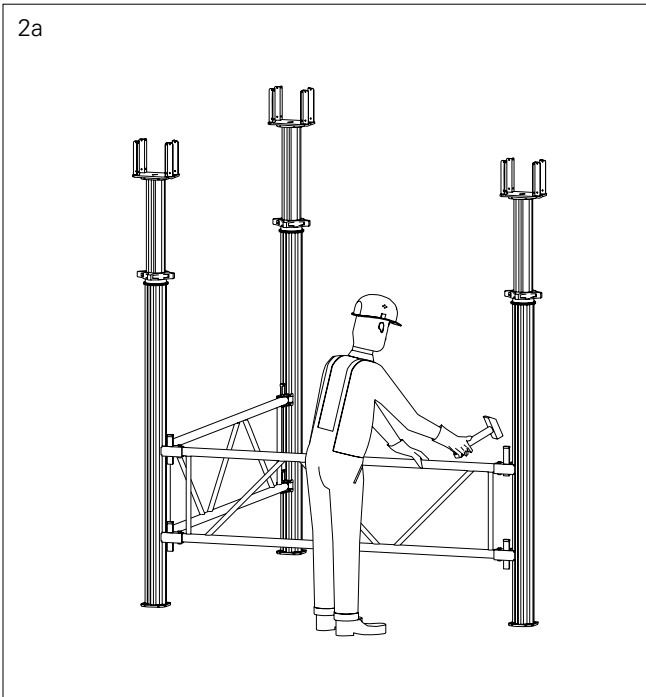

Formwork height > 3.0 m with MULTIPROP Prop
 Brace props with Frame MRK as an assembly aid.
 For further details, see type test and MULTIPROP Instructions for Assembly and Use.



In general, the formwork must be secured to prevent tipping!

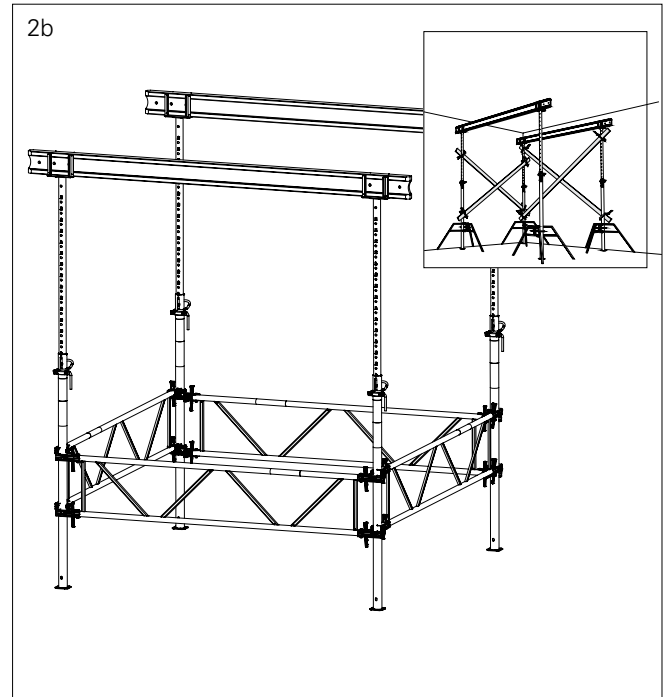

Formwork height > 3.0 m with Steel Tube Prop PEP
 Brace props with Frame PRK as an assembly aid.

Alternatively:
 Mount diagonal bracing as an assembly aid with boards and brace clamps.

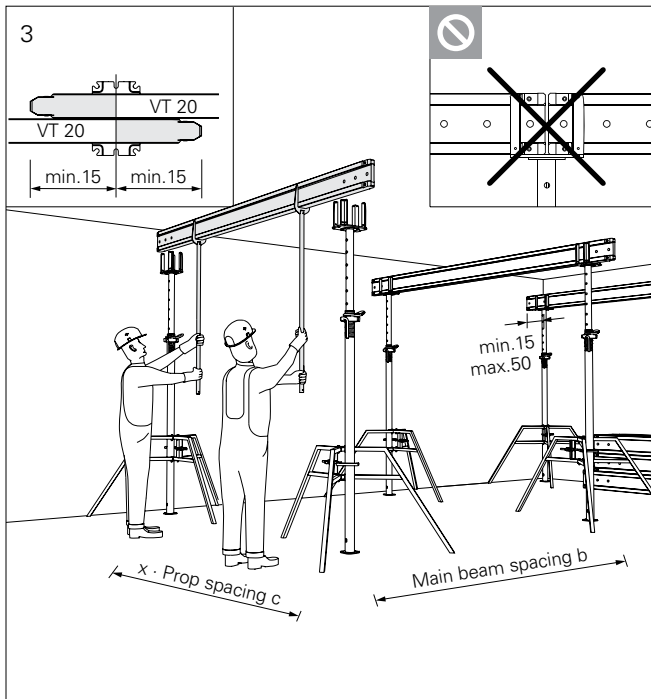

Level the crosshead props. Install the main beam from below with the installation bar.

The crosshead securely supports one or two main beams with no risk of tipping.

Cantilever: VT 20 max. 50 cm
GT 24 max. 45 cm

Do not begin concreting work on the cantilever.



The main beams must be positioned in the crosshead so that they project at least 15 cm over the centre of the girder. They must not come into contact with the crosshead at the end faces!

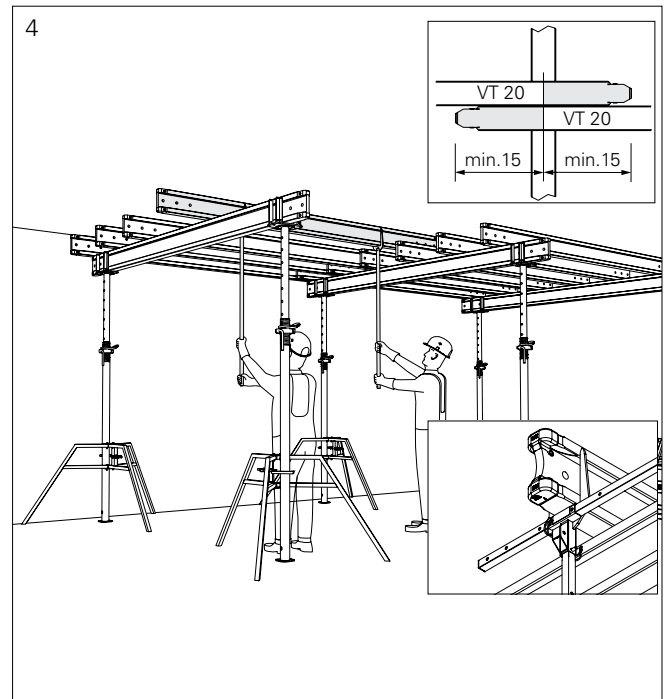

Position the cross girder from below using the installation bar. Align the cross girders in such a way that the formwork panel joint is always resting on a cross girder or a pair of girders.



Using the HAMMOCK Safety System

Alternatively:

Adjust the cross girder spacing with the Distance Gauge MF-Plus thus aligning the cross girder.

Girder overlap on both sides:

VT 20 at least 15.0 cm
GT 24 at least 16.3 cm

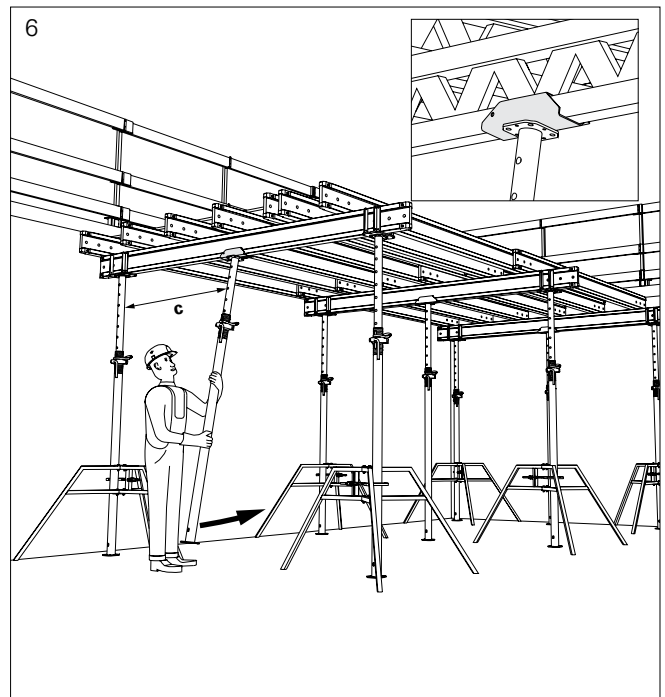
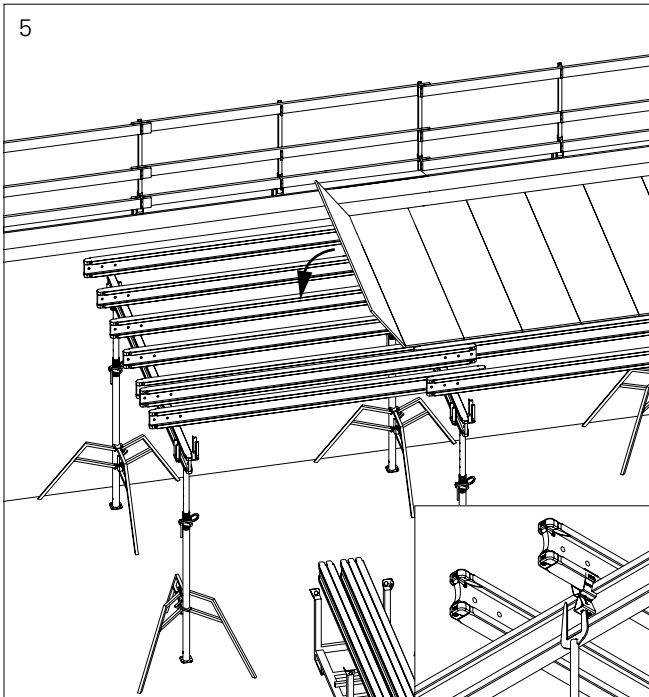

DANGER!

- Working area at a great height!
 Danger to life due to falling!
- Install guardrails before shuttering and according to valid regulations!
 - Use personal protective equipment to prevent falling from a height (PPE)!

Secure cross girders to prevent them from tipping, e.g. with Flexclip MULTIFLEX System.
 Install the formwork panels and secure with nails.
 Level formwork and spray, for example with PERI Bio Clean.
 Caution: slip hazard!



Secure the formwork panels with nails to prevent them from lifting in windy conditions and to stiffen the slab formwork!



DANGER

- Props can tip over if installed incorrectly!
 Toppling slab formwork poses a risk to life!
- Ensure that loads are safely transferred!

Attach intermediate props to the girder using the clawhead at prop spacings c . Adjust the length of props accordingly.

A load can now be applied to the MULTIFLEX Slab Formwork.
 Ensure pallets are available on the erection surface during the striking process.

Formwork assembly

Three combinations are possible with the GT 24 and VT 20 girders:

1. VT 20 / VT 20

(Fig. A3.01)

2. VT 20 / GT 24

(Fig. A3.02)

3. GT 24 / GT 24

(Fig. A3.03)

1. VT 20 / VT 20

Formwork panel 21 mm
Cross Girder VT 20
Main Beam VT 20
h = 42 cm

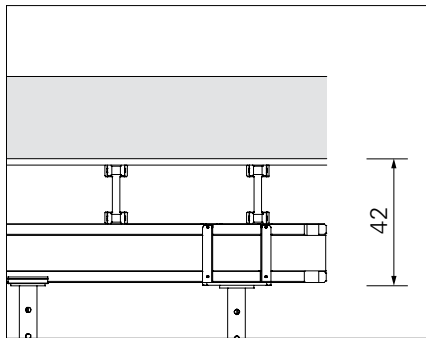

Fig. A3.03

2. VT 20 / GT 24

Formwork panel 21 mm
Cross Girder VT 20
Main Beam GT 24
h = 46 cm

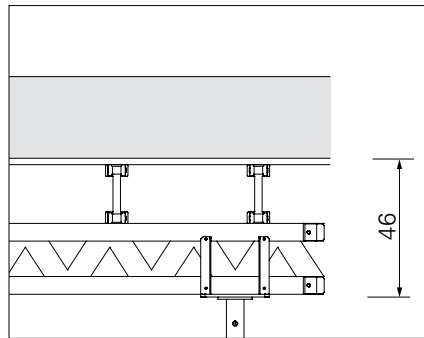

Fig. A3.04

3. GT 24 / GT 24

Formwork panel 21 mm
Cross Girder GT 24
Main Beam GT 24
h = 50 cm

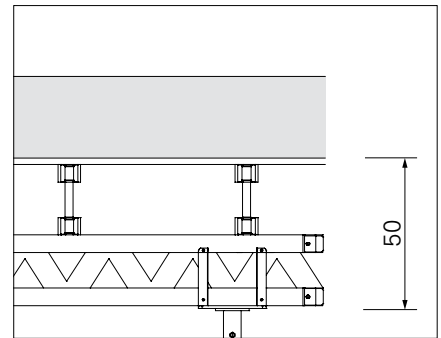

Fig. A3.05

A4 Shuttering the cross girder and securing against tipping

Shuttering cross girders with the Distance Gauge MF-Plus

The Distance Gauge MF-Plus (10) can be adjusted to accommodate different spacings thus eliminating the need to measure the cross beam spacings. In the case of higher ceilings, the telescopic tube can also be extended or lengthened in order to shutter the cross girders from the floor level. (Fig. A4.01)

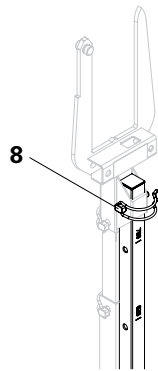

Fig. A4.02

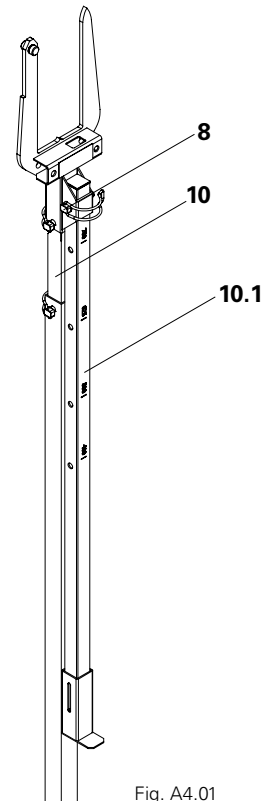

Fig. A4.01

Pre-adjust the Distance Gauge MF-Plus to provide the correct spacing:

1. Pull out the tube clip (8). (Fig. A4.02)
2. Pull the measuring rod (10.1) of the distance gauge (10) out of the holder (a). (Fig. A4.03)
3. Insert the measuring rod (10.1) into the holder (b). When inserting, make sure that the measurements are visible at the top. Adjust the distance gauge to ensure the corresponding cross girder spacing. (Fig. A4.04)
4. Secure with the tube clip (8). (Fig. A4.05)

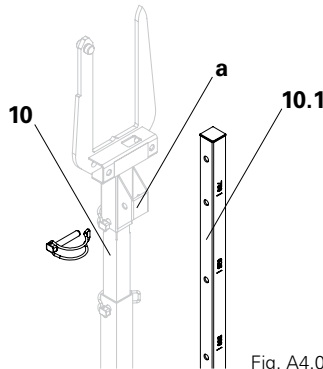

Fig. A4.03

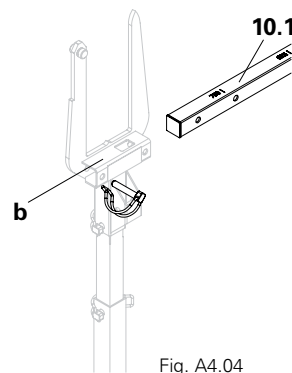

Fig. A4.04

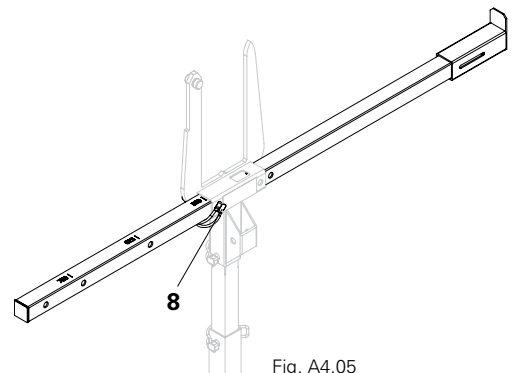

Fig. A4.05

Assembly:

From a safe and secure position below, move the cross girders (1b) to the required spacings using the distance gauge. Move the cross girder (1b) to the left until the distance gauge rests against the cross beam (1b*). This means that it is no longer necessary to carry out a measurement. (Fig. A4.06)

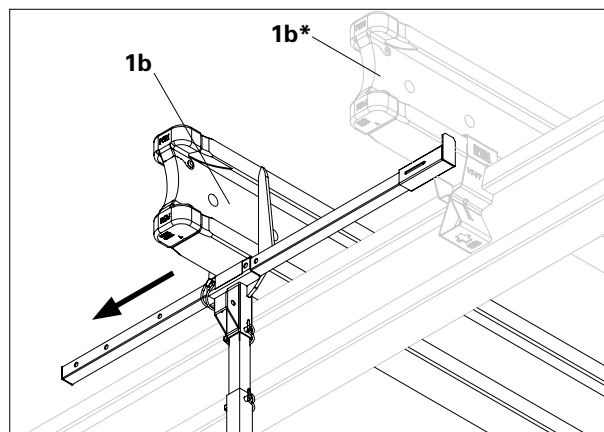

Fig. A4.06

A4 Shuttering the cross girder and securing against tipping

Fitting the Flexclip, fitting the squared timber connector

To secure the cross girders (1b) to prevent them from tilting on the main beam (1a). Assembly is carried out safely from the erection area.

Flexclip variants:

- Flexclip VT20 \ VT20 (Fig. A4.07)
- Flexclip GT24 \ GT24 (Fig. A4.07)
- Flexclip GT24 \ VT20 (Fig. A4.07)

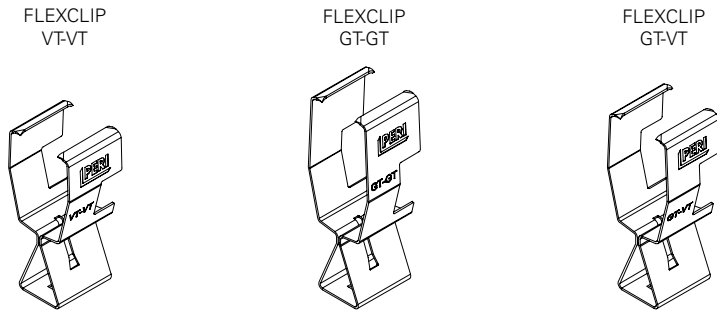

Fig. A4.07



One Flexclip is required for each cross girder. The Flexclip is fitted at one of the joints between the cross girder and longitudinal beam

Assembly at low heights:

1. From the end of the girder, push the Flexclip (7) onto the cross girder (1b) (bottom chord) by hand until it rests against the joint.
2. The cross girder is now secure. (Fig. A4.08)

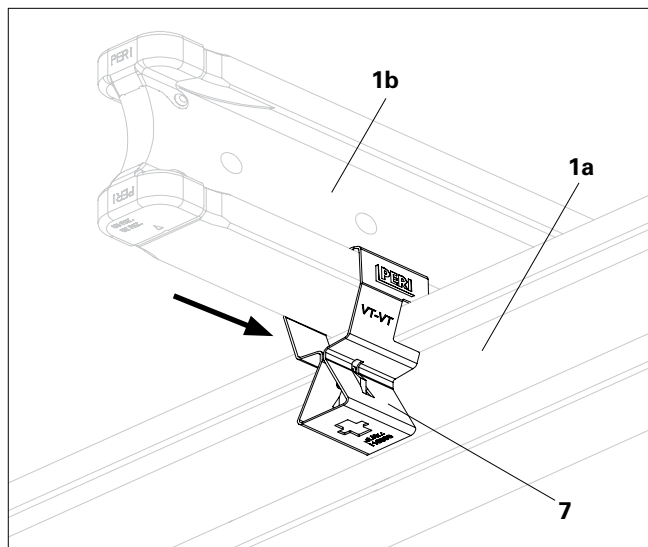

Fig. A4.08

Alternatively:

Squared timber connectors (12) can also be used instead of Flexclips (7). Cross girders (1b) and main beams (1a) are secured by nailing them to the squared timber connector (12). (Fig. A4.09)

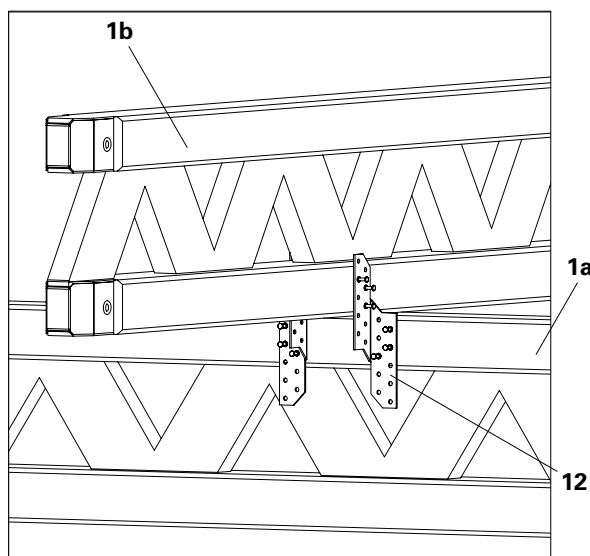

Fig. A4.09

A4 Shuttering the cross girder and securing against tipping

Assembly at greater heights:

1. Use the Distance Gauge MF-Plus (10) to spread the Flexclip (7). (Fig. A4.09)
2. Insert into the cross girder (1b) (bottom chord) and guide to the joint between the cross girder/main beam.
3. Pull the distance gauge downwards out of the Flexclip (7).
4. The Flexclip (7) closes and the cross girder is secured. (Fig. A4.10)

Alternatively:

When fitting the Flexclips, the Fixing Tool MF-Plus (not shown) can also be attached to a wooden butt strap or the telescopic tube.

Removal:

1. Insert the Distance Gauge MF-Plus or Fixing Tool MF-Plus into the Flexclip on the girder thus forcing it open.
2. Carefully pull the Flexclip downwards from the girder.
3. Remove the Flexclip from the distance gauge or fixing tool, and store it in a pallet.

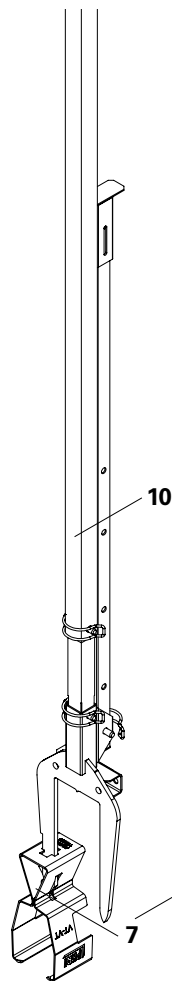

Fig. A4.10

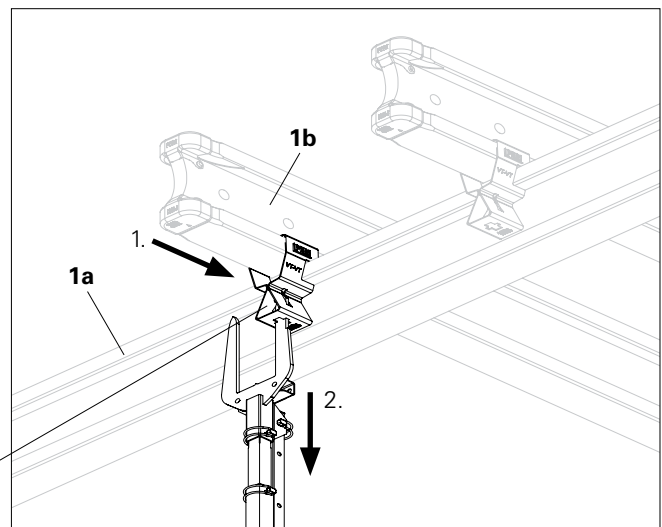

Fig. A4.11

Guardrails at the slab edge with slab tables

The free edge of the building is secured with PERI Slab Tables. (Fig. A5.01)



DANGER

- Bracing not installed with a force fit!
 Danger to life due to risk of collapse!
- Transfer horizontal loads from the upper construction into the building.
 - This can be done by wedging against walls or props.
 - If necessary, use braces or take other suitable measures.

See, for example the Instructions for Assembly and Use for PERI VARIODECK.

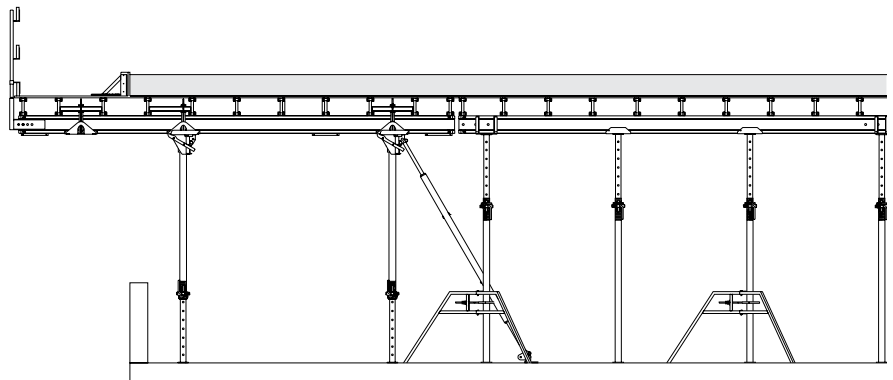

Fig. A5.01

Guardrails on concreting section with slab stop end angle

Assembly

The AW Slab Stopend Angle (11) or Plastic Stopend Angles can be fixed in the longitudinal direction of the girder and at right angles to the girder.

- 8 wire nails $\varnothing 3.1 \times 65$ (6 pieces at front, 2 pieces at rear, article no. 018280).
- The AW Slab Stopend Angle can also be attached to the girder or squared timber with Clamp AW.

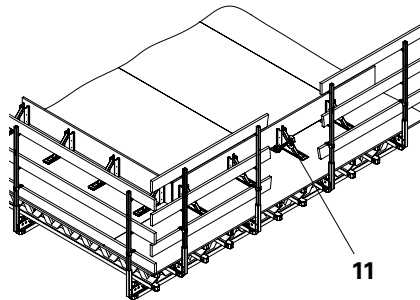

Fig. A5.02

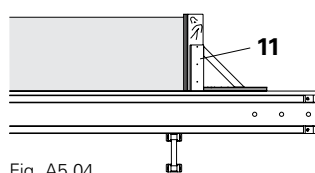

Fig. A5.04

With conventional stop end. (Fig. A5.04)

With panel formwork. (Fig. A5.04a)

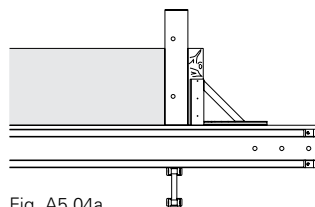

Fig. A5.04a

With Slab Stopend Bar 105 (19) and Guardrail Post HSGP-2 (20). (Fig. A5.03)

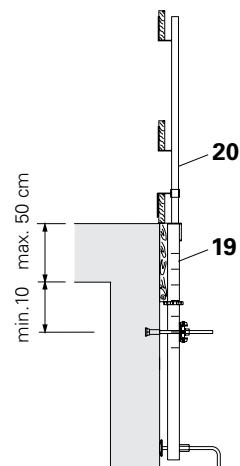

Fig. A5.03

Lateral protection

Secure lateral protection barriers with wire nails!

Technical data

- For permissible influence widths see:
- Instructions for Assembly and Use for PERI Stopend Systems
 - Data sheet for Plastic Stopend Angles

Guardrail with Guardrail Holder GT 24 / VT 20 and Guardrail Post HSGP-2 (e.g. on a concreting section)

Permissible influence width HSGP-2
2.10 m with guardrail boards.
(Fig. A5.05)

When using Formwork Girders VT 20,
only use holes 1 – 3 on the guardrail
holder (**21**)!

– (Fig. A5.05a)

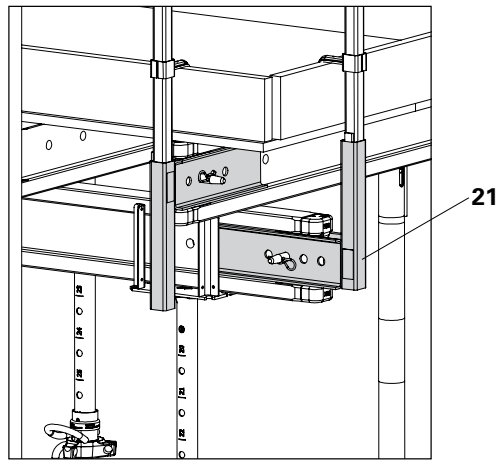

Fig. A5.05

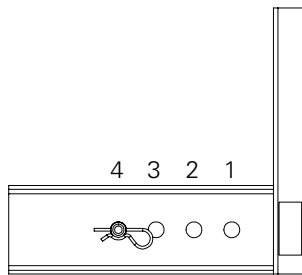

Fig. A5.05a

Bracing VT 20 Girders

VT 20 Girders can be braced with brace connectors or by tensioning with a chain.

Bracing with push-pull props:

The Brace Connector MPB 24 (**15**) can be used to brace VT 20 Girders. (Fig. A6.012)

Filler pins \varnothing 21x120 (**16**) and Cotter Pins 4/1 (**16.1**) can be used for fastening in the second and third holes. (Fig. A6.01 + Fig. A6.01a + Fig. A6.01b)

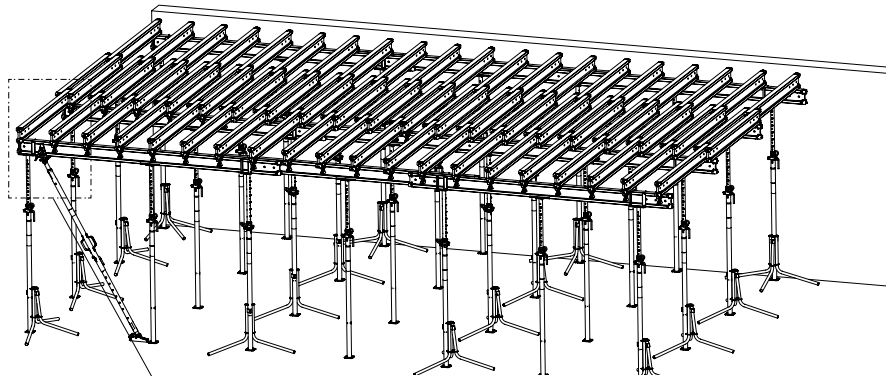

Fig. A6.01



- Note the forces that can be transferred using the push-pull prop (**14**) (see Table A6.01).
- Use suitable fixing material for the anchor chain, e.g. PERI Tie Bolt 14/20x130.

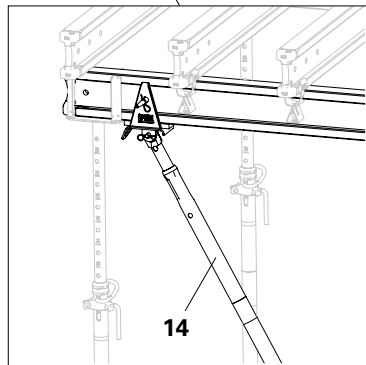

Fig. A6.01a

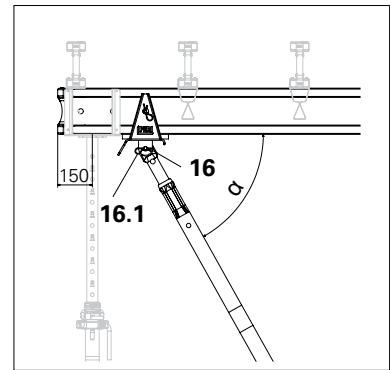

Fig. A6.01b

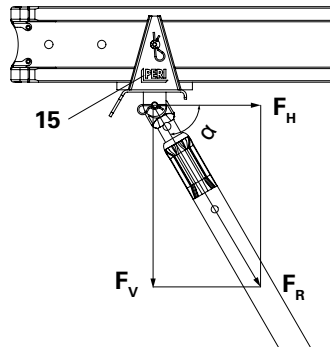

Fig. A6.02

Bracing with push-pull props			
α [°]	Push-pull prop force F_R [kN]	perm. vertical force F_V [kN]	perm. horizontal force F_H [kN]
15	2.3	0.6	2.2
30	2.3	1.1	2.0
45	2.4	1.7	1.7
60	2.7	2.3	1.3
75	3.3	3.1	0.8
90	4.6	4.6	0

Tab. A6.01

Bracing with a chain:

- When bracing with a chain, use the chain holder of the tie plate on the Brace Connector MPB 24 (15).
- Hook the turnbuckle (23) into the chain and base plate (24). Align and fix the base plate to the floor.
- Tension the chain
(Fig. A6.03 + Fig. A6.04)

Components:

- 22 Anchor Chain 250/3.0 kN
- 23 Turnbuckle M12/3.0 kN
- 24 Base Plate

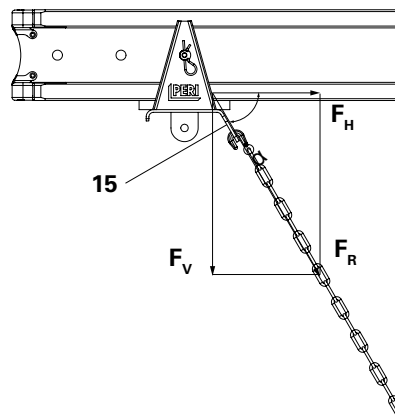

Fig. A6.03

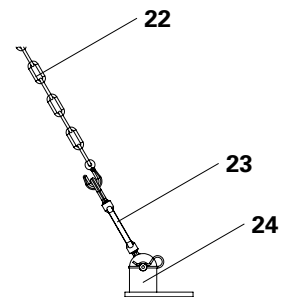

Fig. A6.04

Bracing with a chain			
α [°]	Chain F_R [kN]	perm. vertical force F_V [kN]	perm. horizontal force F_H [kN]
15	2.4	0.6	2.3
30	2.8	1.4	2.4
45	3.0 (3.4)*	2.1 (2.4)*	2.1 (2.4)*
60	3.0 (4.2)*	2.6 (3.6)*	1.3
75	2.7	2.6	0.7
90	2.1	2.1	0

Tab. A6.02

* Values in brackets are maximum values when using chains with a higher load capacity.

Bracing and permissible loads for Girder Headpiece GT 24 / VT 20

The Girder Headpiece GT 24 / VT 20 (13) is used to attach push-pull props to Double Ledgers GT 24 / VT 20. (Fig. A6.05 + Fig. A6.05a + Fig. A6.05b)

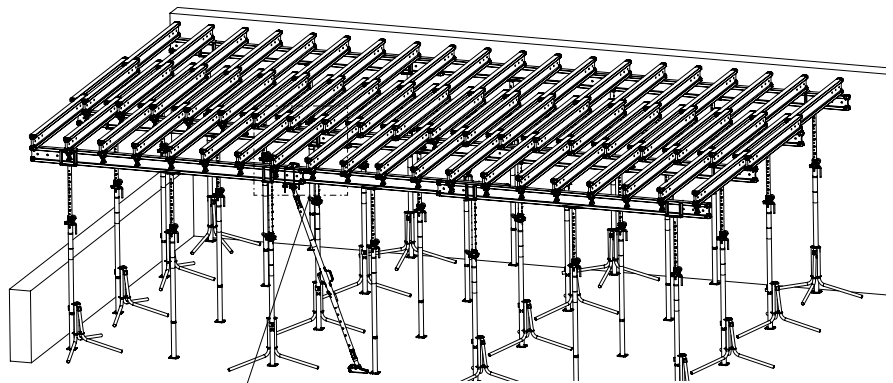

Fig. A6.05

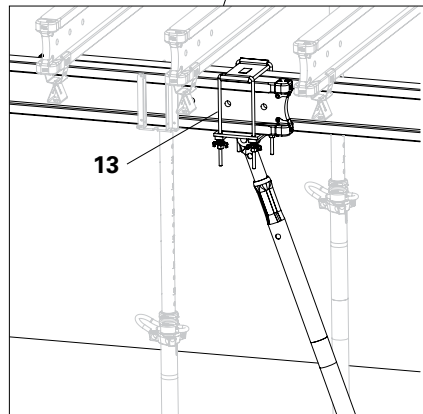

Fig. A6.05a

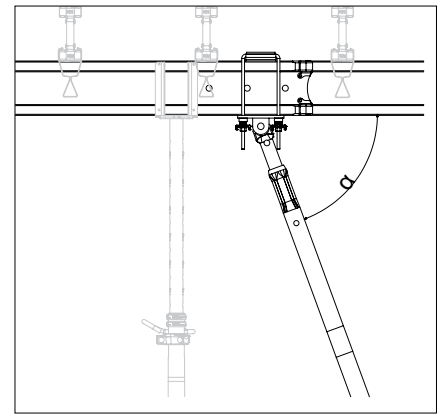
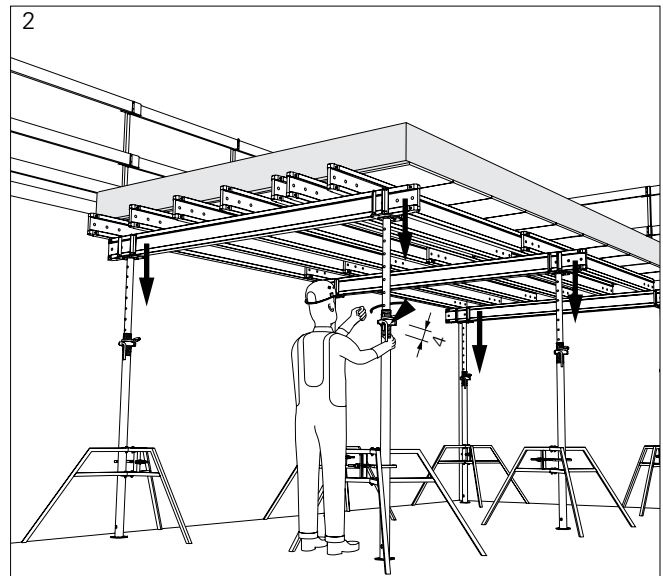
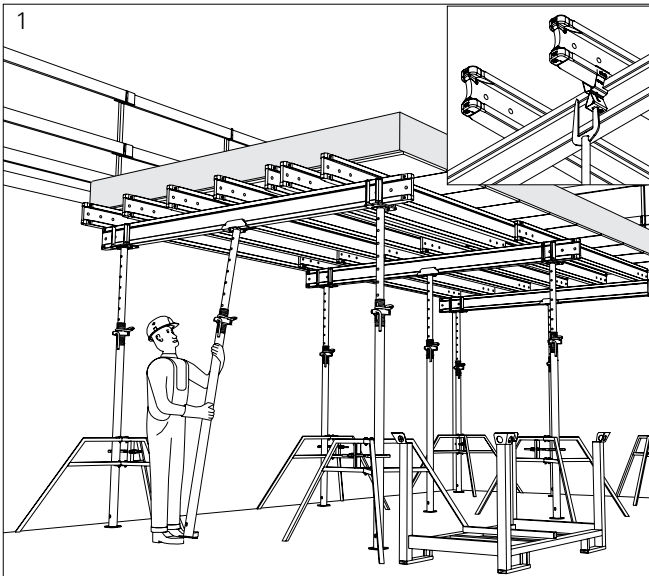

Fig. A6.05b

α [°]	permissible loads	
	GT 24 F [kN]	VT 20 F [kN]
30	8.0	8.0
45	9.8	9.8
60	13.1	13.1

Tab. A6.03



CAUTION

Do not strike the formwork until instructed to do so by a competent person!
 Danger to life if the concrete slab collapses!
 → The curing time must be complied with!

Lower all crosshead props by approx. 4 cm.



For large spans, start lowering and removing the props in the centre of the slab.

Remove intermediate props and store in pallets.
 Remove the Flexclip with the Fixing Tool MF-Plus.
 For horizontal transport, the heads should remain attached to the props!

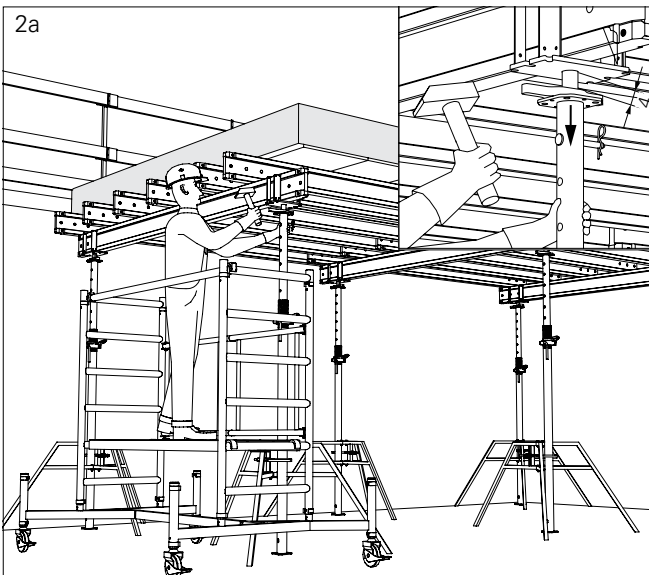

Alternative to image 2

Use a hammer blow to lower the lowering head = 4 cm.



Push the wedge back into its original position for the next use and tap it in firmly with the hammer.

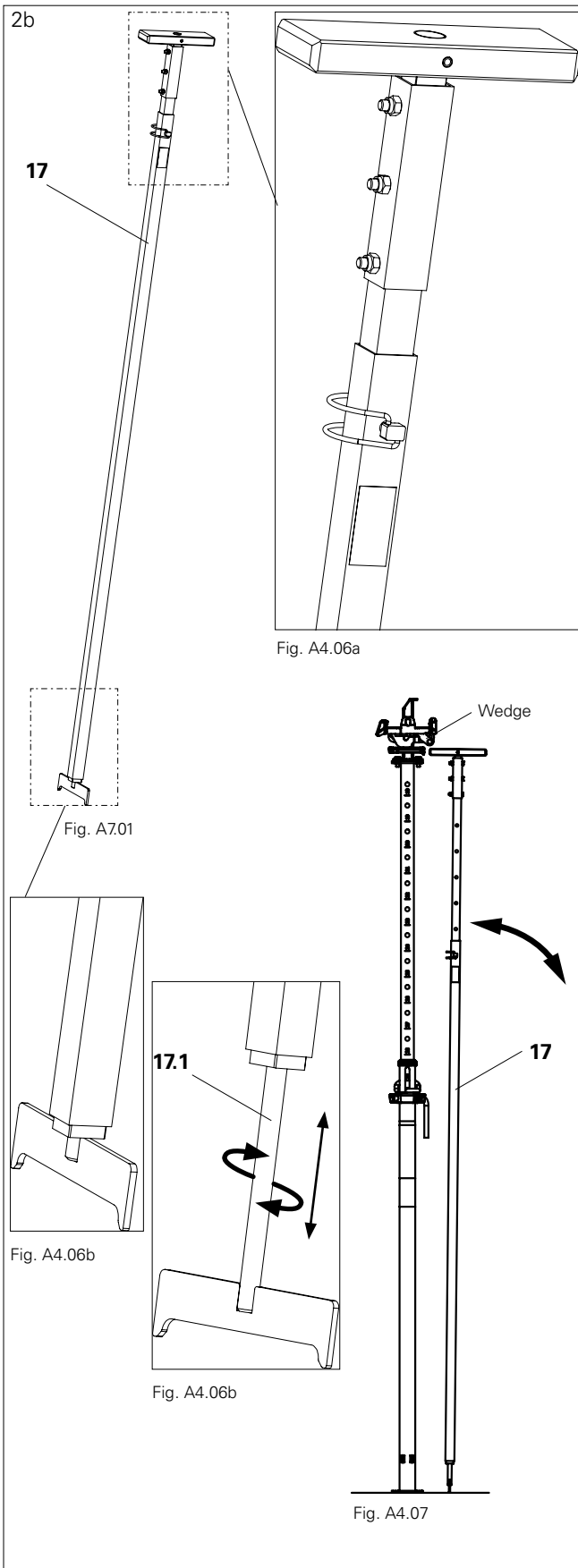

Alternative to image 2

The Striking Hammer SXP SH (17) can be used to loosen the wedge of a lowering head from a safe contact area. (Fig. A4.06 + A4.06a + A4.06b)

Using the Striking Hammer SXP SH:

1. Roughly adjust the length with the setting grid, slightly below the wedge. Make fine adjustments to the length with the Betomax rod (17.1). (Fig. A4.06b)
2. Place the striking hammer on the ground and ensure a firm footing.
3. Carry out the swivelling movement and loosening process and strike the wedge several times with a hammer until it is released. (Fig. A4.07)
4. The length is adjustable in 10 cm increments from 2.00 m to 3.70 m.
5. Fine adjustments are made using the built-in Betomax rod.
 - This can be extended steplessly up to 1.20 m.

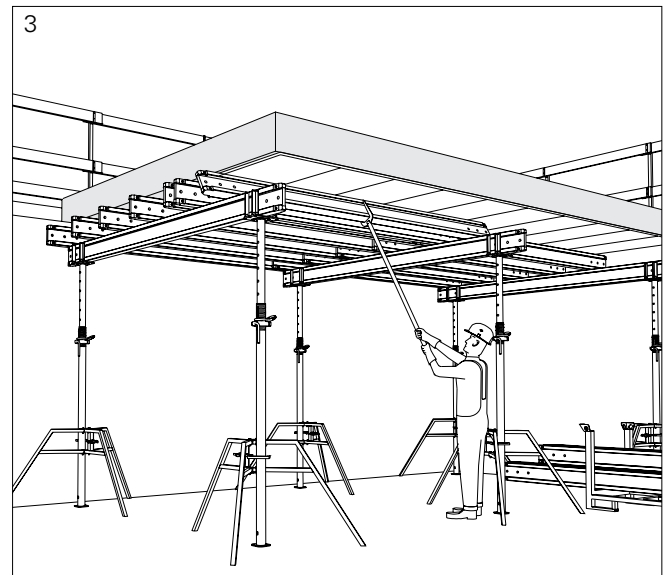

Turn the cross girders over from below using the installation bar, remove them and store in pallets.



- Cross girders beneath the formwork panel joints remain in position.
- Secure the slab props with tripods!

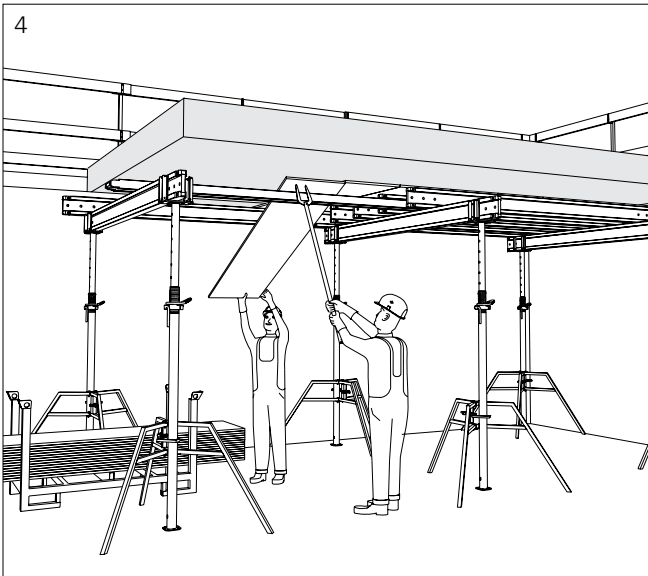

Remove the formwork panels and remaining cross girders and store in pallets.



Stack the formwork panels accurately so that the panel edges can be cleaned in the stack.

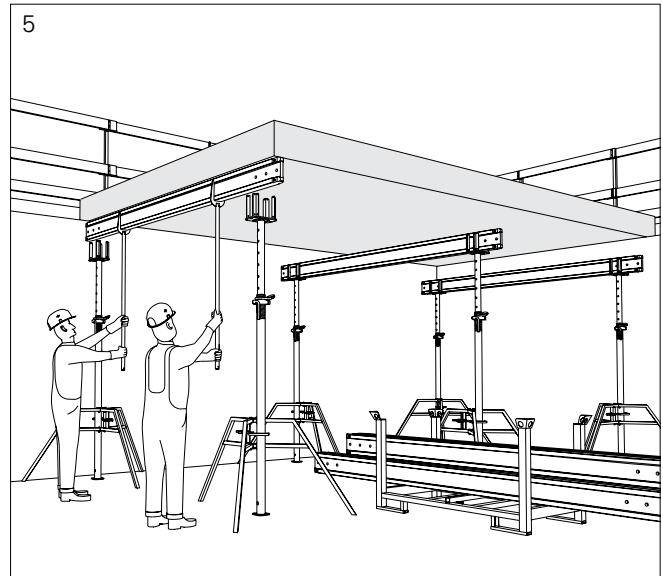

Remove the main beams and store them in pallets. Take prop load into consideration!

If the formwork is not removed or backpropping is used, the props may become overloaded when concreting a slab above.

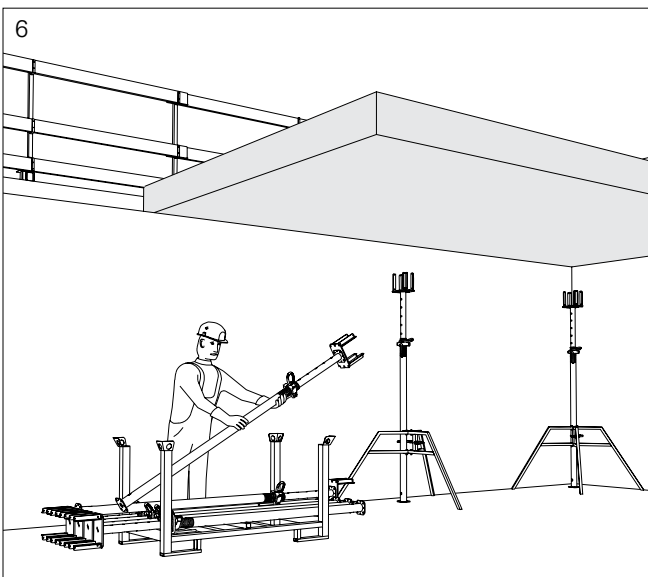

Remove the crosshead props and store them in pallets.



- For horizontal transport, the heads should remain attached to the props!
- Stack the formwork panels accurately so that the panel edges can be cleaned in the stack.

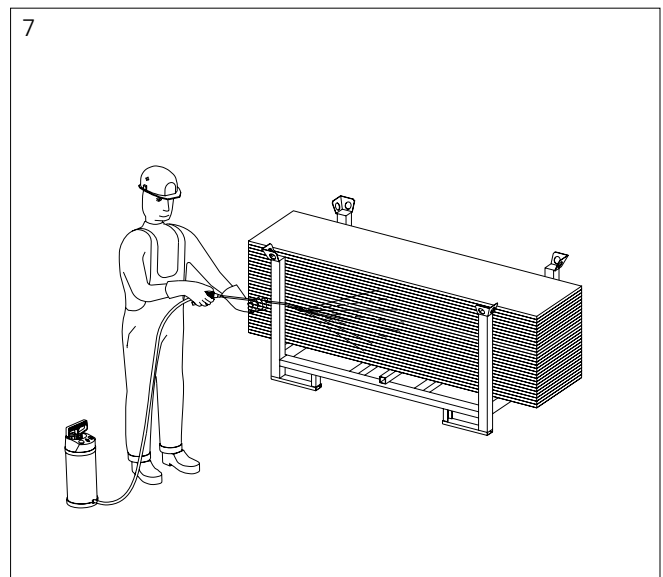

Spray the panel edges with PERI Bio Clean or BTMOS, for example, before using the panels for the first time and every time thereafter. It makes shuttering and deshuttering easier and protects the formwork panel.

With Beam Formwork UZ

For beams up to $h = 80$ cm

Consisting of UZ Beam Bracket 40 (25) and perforated rail (25.1).

- No formwork ties up to $h = 80$ cm.
- Cross-sections are to be formed continuously.
- Girders, squared timber or, for example, TRIO elements, can be used as side and slab formwork.
- For extra-wide beams, the perforated rails can be coupled together.

Max. beam widths

for side plate width $b = 10$ cm

1 x UZ Beam Adjustment Bar 80 = 45 cm

2 x UZ Beam Adjustment Bar 80 = 135 cm

1 x UZ Beam Adjustment Bar 129 = 95 cm

(Fig. A7.01)

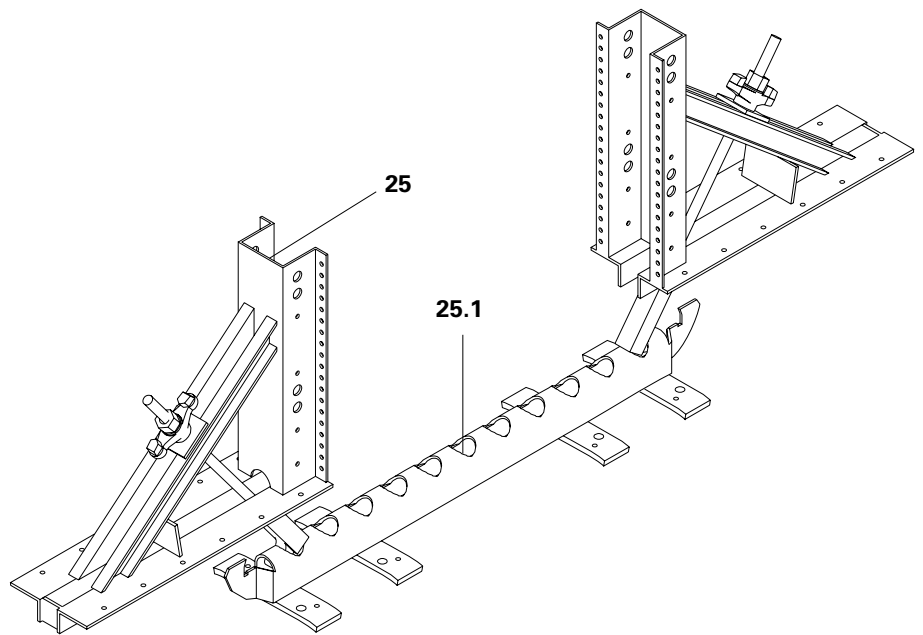

Fig. A7.01

With AW Slab Stopend Angle

For beams up to $h = 60$ cm

The AW Slab Stopend Angle (11) can be nailed to the formwork panel as a stop end up to $h = 40$ cm.

(Fig. A7.02)

With the AW Clamp 8-10 (11.1), larger beams are possible.

(Fig. A7.03)

TRIO, MAXIMO or DOMINO panels, for example, can be used as side formwork.

(Fig. A7.04)

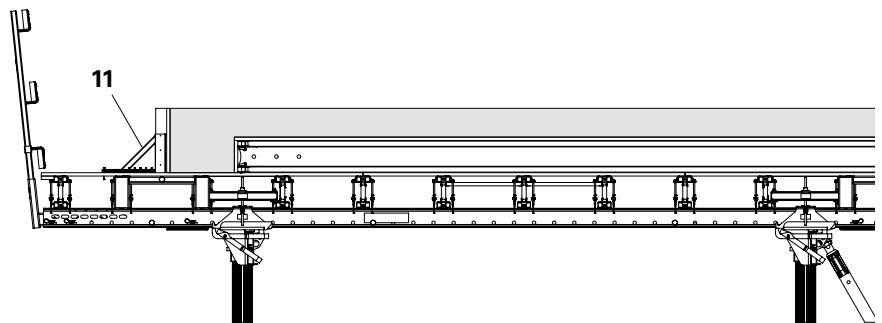

Fig. A7.02



Used formwork panels can be used for working areas.

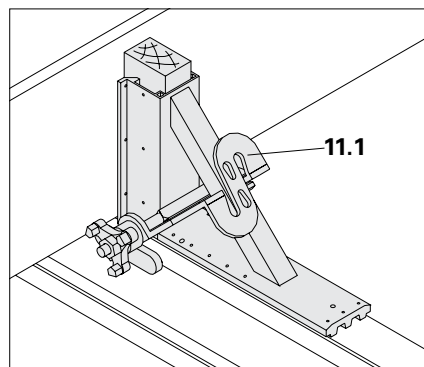

Fig. A7.03

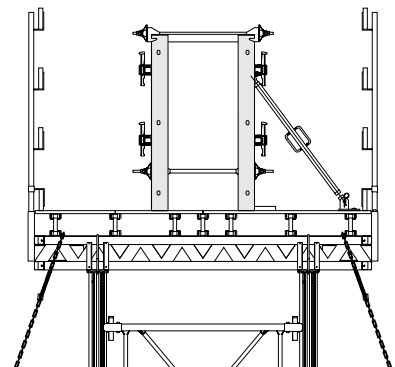
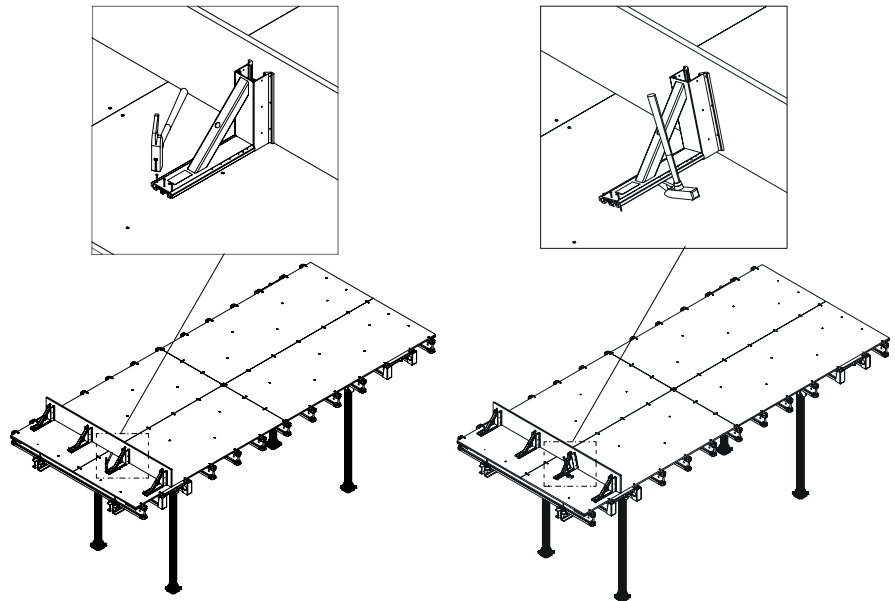

Fig. A7.04

With AW Slab Stopend Angle

Fastening with nails

- Nailing is carried out on the formlining, boards, planks, panels and squared timber.
- Nailing at an angle ensures a better grip and at the same time protects the girder or formlining.
- The nailing joint makes the deshutting process easy.



Fastening with AW Clamp 8 – 10

- Push the AW Clamp 8 – 10 over the AW Slab Stopend Angle.
- Press the AW Slab Stopend Angle together with the clamp firmly against the edge formwork.
- Tighten the nut of the Clamp AW with the hammer.

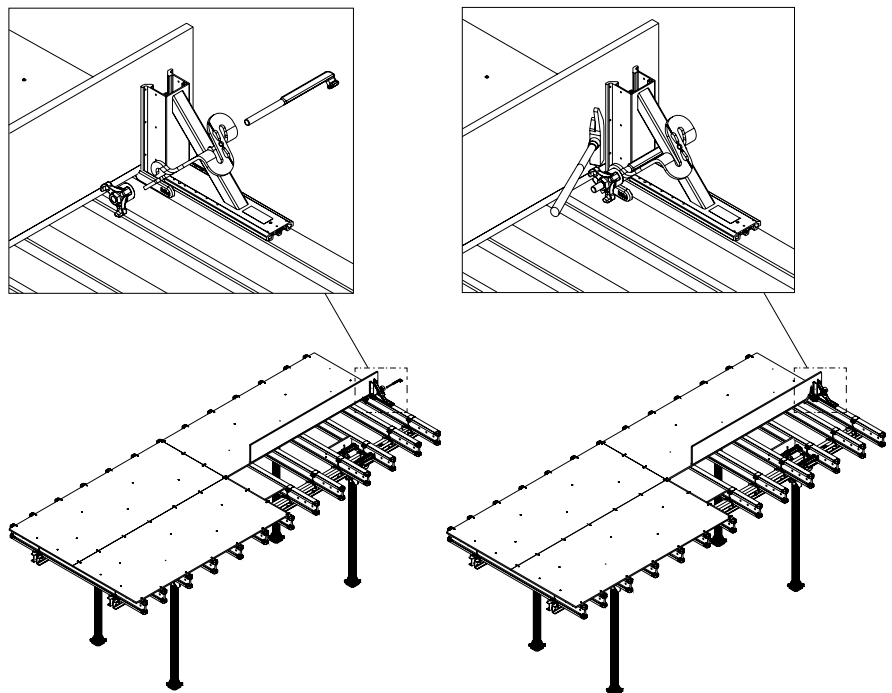

Close open areas and fit lateral protection.



Danger

Risk of falling!

A8 Beams, stop end formwork

With the Plastic Stopend Angle

Nailing is done with 8 nails
Ø 3.1 x 65 mm (6 at the front,
2 at the back).

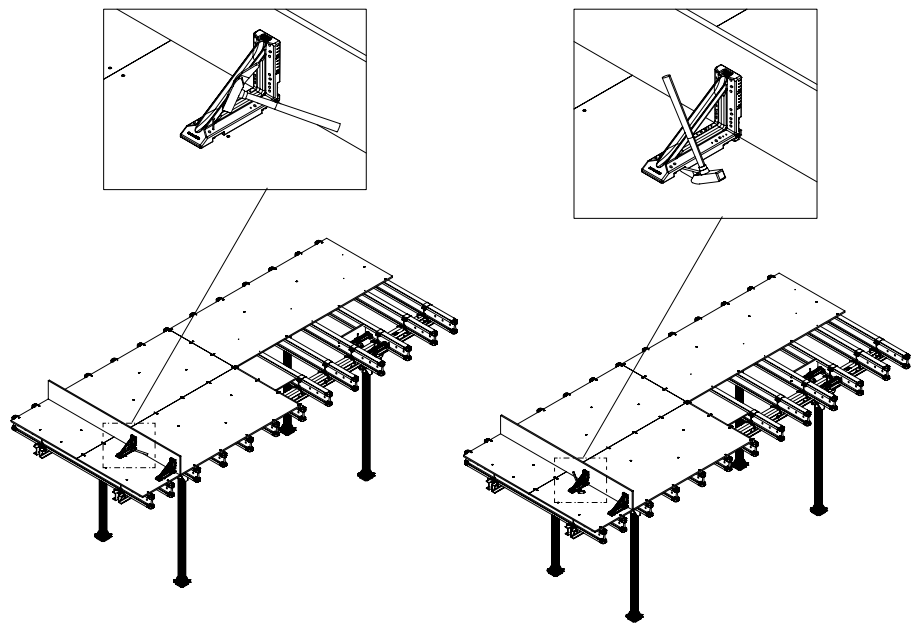

Overview of edge tables

(Fig. A8.01)



The basis of the MULTIFLEX is a slab formwork system that cannot be displaced horizontally on any side!

This is provided by circumferential walls and pre-concreted beams. Otherwise, other on-site measures (e.g. bracing) must be taken to ensure that the horizontal loads are transferred in accordance with applicable standards!

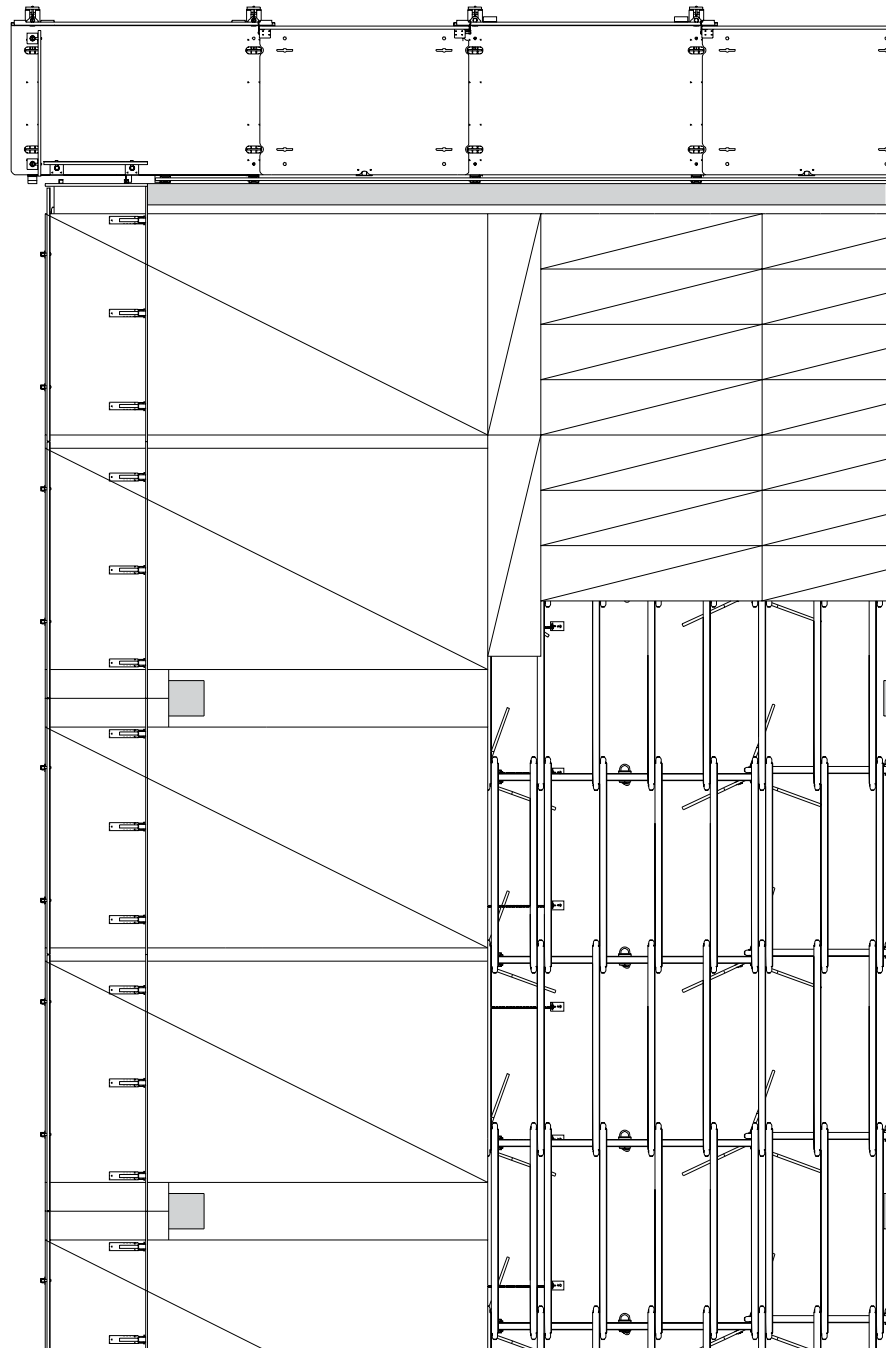

Fig. A8.01

Overview of starting bay

(Fig. A8.02)

VT 20: $c < 75$ cm; $e = c/2$

VT 20: $c \geq 75$ cm; $e = 50$ cm

GT 24: $c < 90$ cm; $e = 30$ cm

GT 24: $c \geq 90$ cm; $e = 45$ cm

c : width of main beam interior span or prop spacing

e : length of cantilever

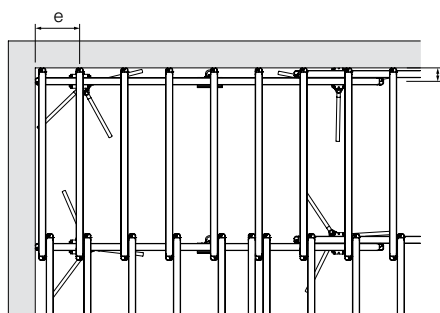

Fig. A8.02

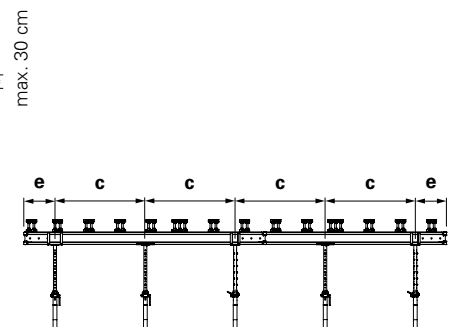
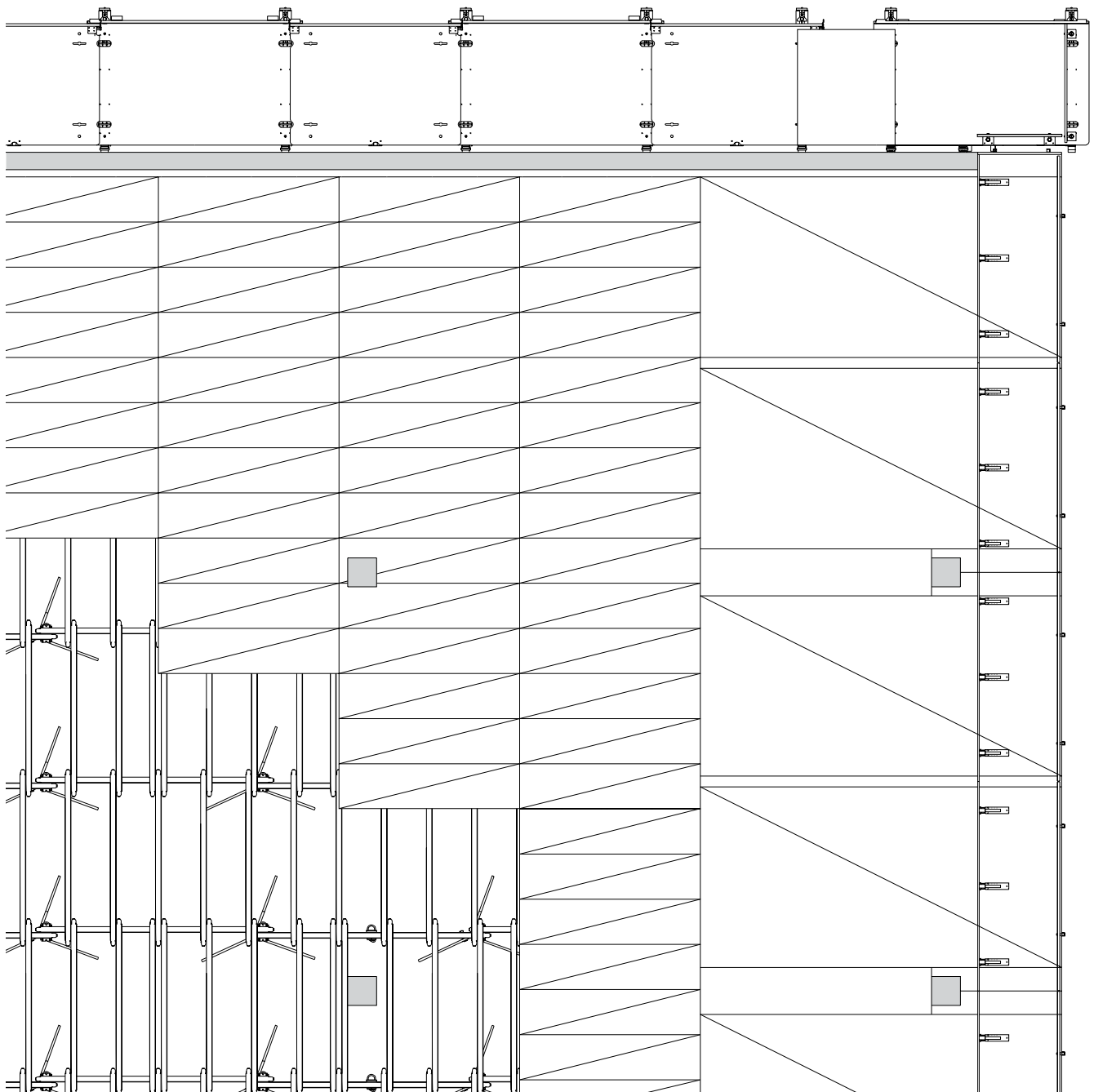

Fig. A8.03

Use the HAMMOCK Safety System!



PERI Design Tables

Example: structural design with VT 20/VT 20 girder combination

Slab thickness: $d = 20$ cm
 Clear room height: $h = 2.80$ m
 Main beam and cross girder: VT 20
 Formwork panel: 21 mm,
 62.5 x 250 cm

Slab thickness d [m]		0.10			0.12			0.14			0.16			0.18			0.20			
Load q^* [kN/m ²]		4.4			4.8			5.3			5.8			6.3			6.8			
Cross girder spacing a [m]		0.75	0.625	0.50	0.75	0.625	0.50	0.75	0.625	0.50	0.75	0.625	0.50	0.75	0.625	0.50	0.75	0.625	0.50	
Cantilever e [m]	0.25	0.50	3.21	3.41	3.67	3.04	3.23	3.48	2.91	3.09	3.33	2.79	2.97	3.20	2.70	2.86	3.09	2.61	2.77	2.99
			7.3	7.8	8.4	7.7	8.2	8.9	8.1	8.6	9.3	8.5	9.1	9.8	8.9	9.5	10.2	9.3	9.9	10.7
	0.375	0.75	3.21	3.41	3.67	3.04	3.23	3.48	2.91	3.09	3.33	2.79	2.97	3.20	2.70	2.86	3.09	2.61	2.77	2.99
			11.0	11.7	12.6	11.6	12.3	13.3	12.2	13.0	14.0	12.8	13.6	14.7	13.4	14.2	15.3	14.0	14.9	16.0
	0.50	1.00	3.21	3.41	3.67	3.04	3.23	3.48	2.91	3.09	3.33	2.79	2.97	3.20	2.70	2.86	3.09	2.61	2.77	2.99
			14.7	15.6	16.8	15.5	16.4	17.7	16.3	17.3	18.6	17.1	18.1	19.5	17.9	19.0	20.4	18.6	19.8	21.3
	0.50	1.25	3.21	3.41	3.67	3.04	3.23	3.46	2.91	3.09	3.14	2.79	2.88	2.88	2.66	2.66	2.66	2.46	2.46	2.46
			18.3	19.5	21.0	19.3	20.5	22.0	20.3	21.6	22.0	21.3	22.0	22.0	22.0	22.0	22.0	22.0	22.0	22.0
	0.50	1.50	3.21	3.21	3.21	2.89	2.89	2.89	2.62	2.62	2.62	2.40	2.40	2.40	2.21	2.21	2.21	2.05	2.05	2.05
			22.0	22.0	22.0	22.0	22.0	22.0	22.0	22.0	22.0	22.0	22.0	22.0	22.0	22.0	22.0	22.0	22.0	22.0
	0.50	1.75	2.75	2.75	2.75	2.47	2.47	2.47	2.25	2.25	2.25	2.06	2.06	2.06	1.90	1.90	1.90	1.76	1.76	1.76
			22.0	22.0	22.0	22.0	22.0	22.0	22.0	22.0	22.0	22.0	22.0	22.0	22.0	22.0	22.0	22.0	22.0	22.0
0.50	2.00	2.41	2.41	2.41	2.16	2.16	2.16	1.97	1.97	1.97	1.80	1.80	1.80	1.66	1.66	1.66	1.54	1.54	1.54	
		22.0	22.0	22.0	22.0	22.0	22.0	22.0	22.0	22.0	22.0	22.0	22.0	22.0	22.0	22.0	22.0	22.0	22.0	

Formlining

The 3-S panel, 21 mm, has been included. For the values of other panels, see PERI Design Tables.

1. Cross girder spacing a

Formlining support is dependent on the slab thickness and the type of formwork panel used. (Fig. A9.02).

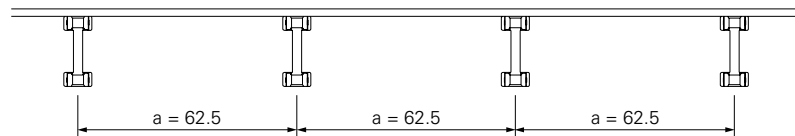

Fig. A9.02

Cross girder spacing 62.5 cm

2. Main beam spacing b

Support for the cross girders. Permissible span for cross girder according to PERI Design Tables: 2.05 m.

Selected: 2.00 m, depending on the spatial geometry. (Fig. A9.03)

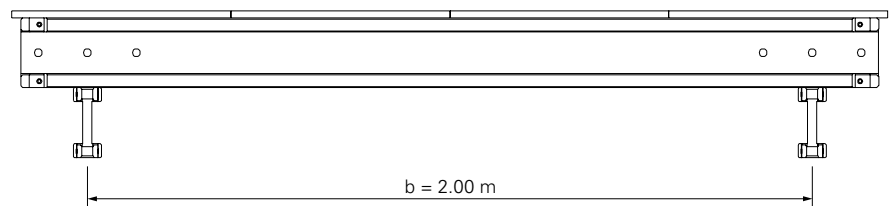

Fig. A9.03

Main beam spacing: 2.00 m

3. Prop spacing c

Support for the main beams.
(Fig. A9.04)

Prop spacing 1.50 m

4. Prop load

Value from the PERI Design Tables = 22.0 kN.

Selecting a main beam spacing of $b = 2.00$ m results in the following prop load to be supported:

$$F = 22 \text{ kN} \times \frac{2.00 \text{ m}}{2.05 \text{ m}} = \mathbf{21.5 \text{ kN}}$$

Select the PERI Slab Prop (PEP; MULTIPROP) corresponding to the extension length h with permissible prop load = 21.5 kN.

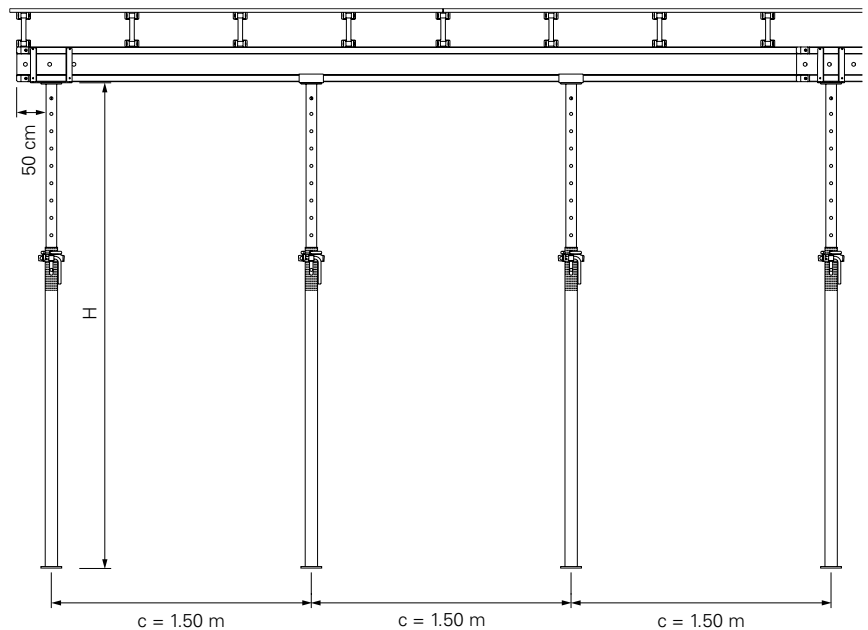

Fig. A9.04

Example with PERI Design Tables

Carry out the structural design for the MULTIFLEX Slab Formwork according to the girder combination using the Design Tables.

The main beam and prop spacing is dependent on the slab thickness, selected cross girder spacing and formwork panel.
(Fig. A9.05)



PERI MULTIFLEX Configurator

Calculations for quickly optimizing the girder/prop spacings and MULTIFLEX girders can also be easily realized using the PERI MULTIFLEX Configurator. The PERI MULTIFLEX Configurator is also available for smartphones and tablets.

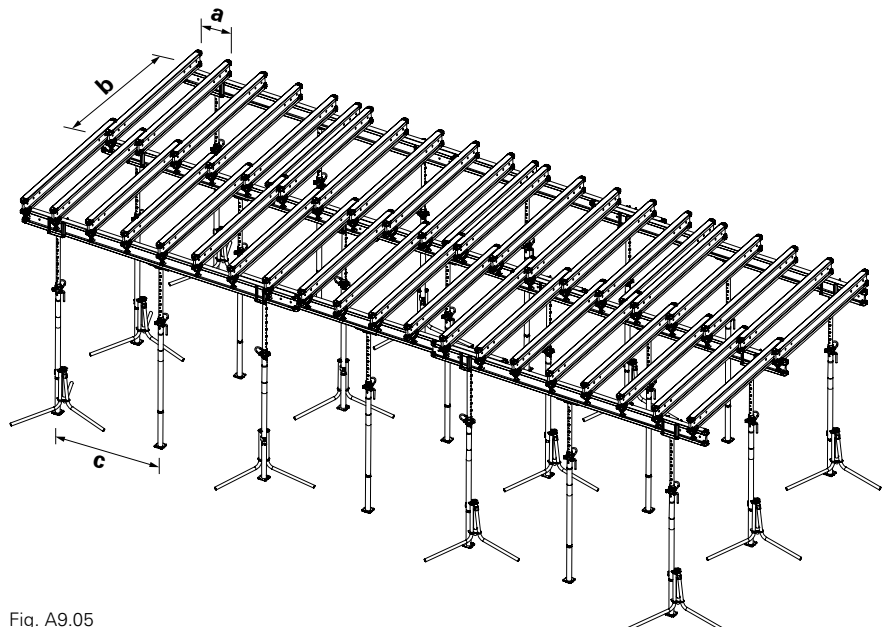

Fig. A9.05

Formlining

Overview, static values

Formwork panels

Panel type	Thickness [mm]	Veneers	Modulus of elasticity [N/mm ²] parallel/transverse	Perm. σ [N/mm ²] parallel/transverse
Fin-Ply	21	Birch	8560/6610	15.0/12.4
Fin-Ply, Maxi	20	Birch	7500/5760	13.0/10.5
Fin-Ply, USA	19 / ¾"	Birch	6180/6880	12.0/11.5
Fin-Ply	18	Birch	8730/6440	15.3/12.2
PERI Birch	21	Birch	8560/6610	15.0/12.4
PERI Birch, USA	19 / ¾"	Birch	9170/7060	15.7/13.6
PERI Spruce 400	21	Softwood	7000/4130	8.3/6.3
3-S panel	27	Spruce	8000/1070	4.9/1.5
3-S panel	21	Spruce	8000/1070	5.9/1.3
FinNa-Ply	21	Softwood	7910/3710	8.0/5.0

The static/mechanical values given in the table refer to a wood moisture content of 15 % based on the manufacturer information.

However, according to the GSV, the values should take into consideration a wood moisture content of 20 %. Therefore, the values for the modulus of elasticity must be reduced by a factor of 0.9167 and the values for the permissible stress by a factor of 0.875.

The fibres of the face veneer are tensioned in the direction of the first length specification of the panel dimension.

Solid timber

	Modulus of elasticity [N/mm ²] parallel	Perm. σ [N/mm ²] parallel
Softwood timber, strength class C24	11000	11

The permissible value according to DIN 1052 results in a short duration of load for Application Class 2.

Formlining

Panel thickness 21 mm

The modulus of elasticity and the permissible stress are based on the grade and moisture content of the panel.
(See "Overview, Static Values")

max. deflection

$$f = \frac{0.0068 \cdot \sigma_{hk} \cdot L^4}{E \cdot I}$$

max. moment

$$M = 0.1071 \cdot \sigma_{hk} \cdot L^2$$

(valid for at least 3 bays)

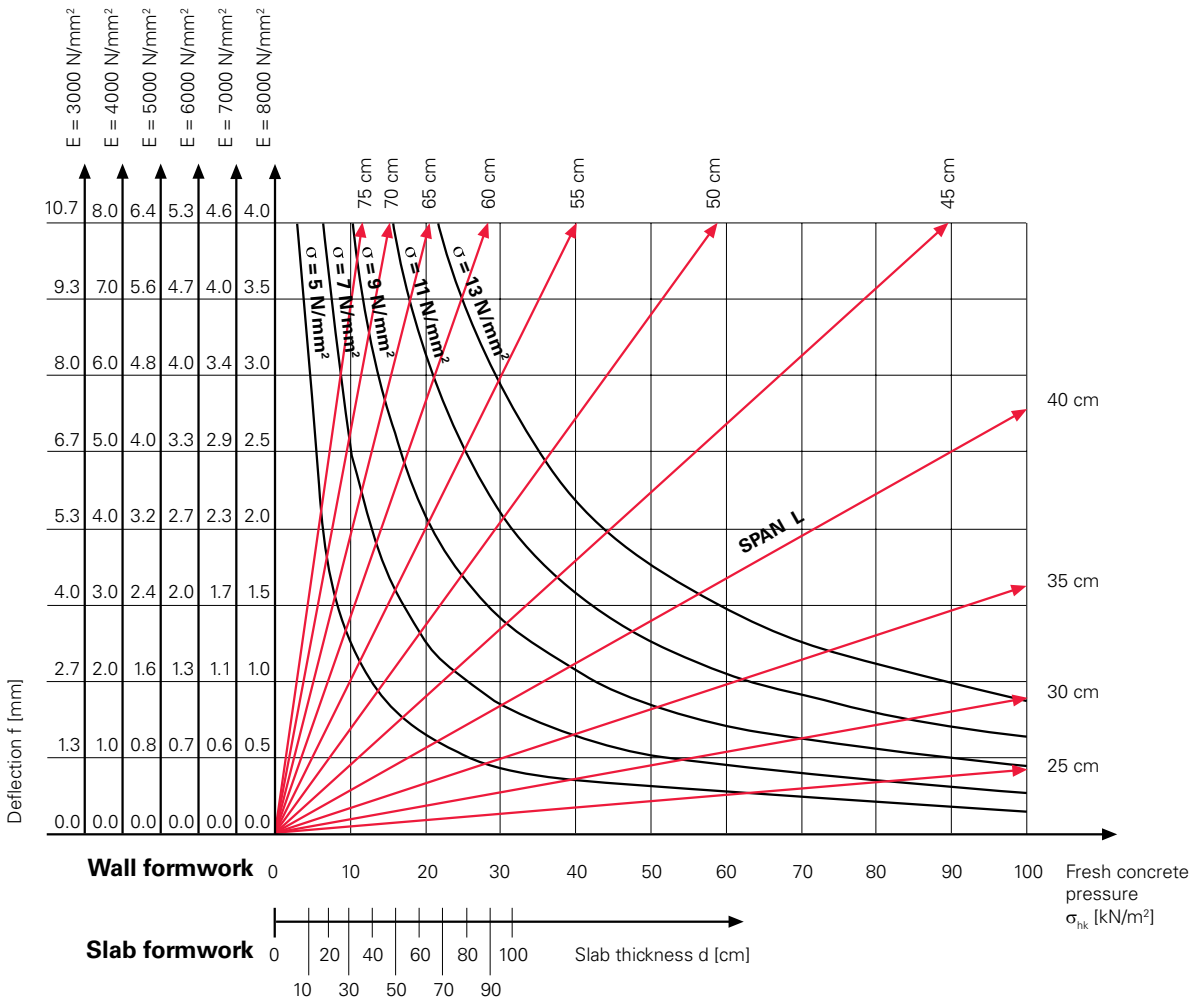
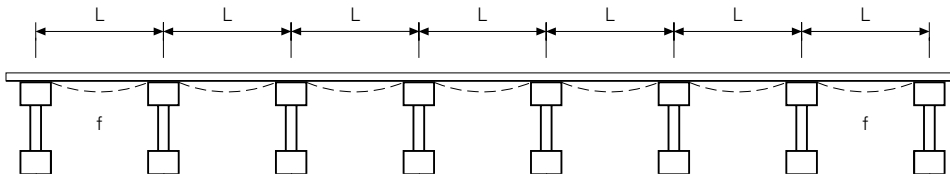

Slab thickness d [m]		0.10			0.12			0.14			0.16			0.18			0.20			
Load q* [kN/m²]		4.4			4.8			5.3			5.8			6.3			6.8			
Cross girder spacing a [m]		0.75	0.625	0.50	0.75	0.625	0.50	0.75	0.625	0.50	0.75	0.625	0.50	0.75	0.625	0.50	0.75	0.625	0.50	
Cantilever e [m]	0.30	0.60	3.99	4.24	4.57	3.79	4.03	4.34	3.62	3.85	4.14	3.48	3.70	3.98	3.36	3.57	3.84	3.25	3.45	3.72
			10.9	11.6	12.5	11.6	12.3	13.2	12.2	12.9	13.9	12.8	13.5	14.6	13.3	14.2	15.3	13.9	14.8	15.9
	0.45	0.90	3.99	4.24	4.57	3.79	4.03	4.34	3.62	3.85	4.14	3.48	3.70	3.98	3.36	3.57	3.84	3.25	3.45	3.72
			16.4	17.4	18.8	17.3	18.4	19.8	18.2	19.4	20.9	19.1	20.3	21.9	20.0	21.3	22.9	20.9	22.2	23.9
	0.45	1.20	3.99	4.24	4.57	3.79	4.03	4.34	3.62	3.85	4.14	3.48	3.70	3.82	3.36	3.52	3.52	3.25	3.27	3.27
			21.9	23.3	25.1	23.1	24.6	26.4	24.3	25.8	27.8	25.5	27.1	28.0	26.7	28.0	28.0	27.8	28.0	28.0
	0.45	1.50	3.99	4.09	4.09	3.67	3.67	3.67	3.34	3.34	3.34	3.05	3.05	3.05	2.82	2.82	2.82	2.61	2.61	2.61
			27.4	28.0	28.0	28.0	28.0	28.0	28.0	28.0	28.0	28.0	28.0	28.0	28.0	28.0	28.0	28.0	28.0	28.0
	0.45	1.80	3.41	3.41	3.41	3.06	3.06	3.06	2.78	2.78	2.78	2.55	2.55	2.55	2.35	2.35	2.35	2.18	2.18	2.18
			28.0	28.0	28.0	28.0	28.0	28.0	28.0	28.0	28.0	28.0	28.0	28.0	28.0	28.0	28.0	28.0	28.0	28.0
	0.45	2.10	2.92	2.92	2.92	2.62	2.62	2.62	2.38	2.38	2.38	2.18	2.18	2.18	2.01	2.01	2.01	1.87	1.87	1.87
			28.0	28.0	28.0	28.0	28.0	28.0	28.0	28.0	28.0	28.0	28.0	28.0	28.0	28.0	28.0	28.0	28.0	28.0

Slab thickness d [m]		0.22			0.24			0.25			0.26			0.28			0.30			
Load q* [kN/m²]		7.3			7.8			8.0			8.3			8.8			9.3			
Cross girder spacing a [m]		0.75	0.625	0.50	0.625	0.50	0.40	0.625	0.50	0.40	0.625	0.50	0.40	0.625	0.50	0.40	0.625	0.50	0.40	
Cantilever e [m]	0.30	0.60	3.15	3.35	3.61	3.26	3.51	3.79	3.22	3.47	3.74	3.18	3.43	3.69	3.11	3.35	3.61	3.04	3.28	3.53
			14.5	15.4	16.6	16.0	17.2	18.6	16.3	17.5	18.9	16.6	17.9	19.2	17.2	18.5	19.9	17.7	19.1	20.6
	0.45	0.90	3.15	3.35	3.61	3.26	3.51	3.79	3.22	3.47	3.69	3.18	3.43	3.58	3.11	3.35	3.38	3.04	3.20	3.20
			21.7	23.1	24.9	24.0	25.8	27.8	24.4	26.3	28.0	24.9	26.8	28.0	25.7	27.7	28.0	26.6	28.0	28.0
	0.45	1.20	3.05	3.05	3.05	2.86	2.86	2.86	2.77	2.77	2.77	2.69	2.69	2.69	2.54	2.54	2.54	2.40	2.40	2.40
			28.0	28.0	28.0	28.0	28.0	28.0	28.0	28.0	28.0	28.0	28.0	28.0	28.0	28.0	28.0	28.0	28.0	28.0
	0.45	1.50	2.44	2.44	2.44	2.29	2.29	2.29	2.22	2.22	2.22	2.15	2.15	2.15	2.03	2.03	2.03	1.92	1.92	1.92
			28.0	28.0	28.0	28.0	28.0	28.0	28.0	28.0	28.0	28.0	28.0	28.0	28.0	28.0	28.0	28.0	28.0	28.0
	0.45	1.80	2.03	2.03	2.03	1.90	1.90	1.90	1.85	1.85	1.85	1.79	1.79	1.79	1.69	1.69	1.69	1.60	1.60	1.60
			28.0	28.0	28.0	28.0	28.0	28.0	28.0	28.0	28.0	28.0	28.0	28.0	28.0	28.0	28.0	28.0	28.0	28.0
	0.45	2.10	1.74	1.74	1.74	1.63	1.63	1.63	1.58	1.58	1.58	1.54	1.54	1.54	1.45	1.45	1.45	1.37	1.37	1.37
			28.0	28.0	28.0	28.0	28.0	28.0	28.0	28.0	28.0	28.0	28.0	28.0	28.0	28.0	28.0	28.0	28.0	28.0

Slab thickness d [m]		0.35	0.40	0.45	0.50	0.60	0.70	0.80	0.90	1.00										
Load q* [kN/m ²]		10.6	11.9	13.3	14.6	17.3	20.0	22.5	25.0	27.4										
Cross girder spacing a [m]		0.50	0.40	0.50	0.40	0.50	0.40	0.50	0.40	0.50	0.40	0.50	0.40	0.50	0.40	0.50	0.40	0.50	0.40	
Cantilever e [m]	0.30	0.60	3.12	3.36	2.99	3.22	2.88	3.10	2.77	3.00	2.54	2.57	2.22	2.22	1.98	1.98	1.78	1.78	1.62	1.62
			20.8	22.4	22.5	24.2	24.1	25.9	25.5	27.6	27.7	28.0	28.0	28.0	28.0	28.0	28.0	28.0	28.0	28.0
	0.45	0.90	2.80	2.80	2.48	2.48	2.23	2.23	2.03	2.03	1.71	1.71	1.48	1.48	1.32	1.32	1.19	1.19	1.08	1.08
			28.0	28.0	28.0	28.0	28.0	28.0	28.0	28.0	28.0	28.0	28.0	28.0	28.0	28.0	28.0	28.0	28.0	28.0
	0.45	1.20	2.10	2.10	1.86	1.86	1.67	1.67	1.52	1.52	1.28	1.28	1.11	1.11	0.99	0.99	0.89	0.89	0.81	0.81
			28.0	28.0	28.0	28.0	28.0	28.0	28.0	28.0	28.0	28.0	28.0	28.0	28.0	28.0	28.0	28.0	28.0	28.0
	0.45	1.50	1.68	1.68	1.49	1.49	1.34	1.34	1.22	1.22	1.03	1.03	0.89	0.89	0.79	0.79	0.71	0.71	0.65	0.65
			28.0	28.0	28.0	28.0	28.0	28.0	28.0	28.0	28.0	28.0	28.0	28.0	28.0	28.0	28.0	28.0	28.0	28.0
	0.45	1.80	1.40	1.40	1.24	1.24	1.12	1.12	1.01	1.01	0.86	0.86	0.74	0.74	0.66	0.66	0.59	0.59	0.54	0.54
			28.0	28.0	28.0	28.0	28.0	28.0	28.0	28.0	28.0	28.0	28.0	28.0	28.0	28.0	28.0	28.0	28.0	28.0
	0.45	2.10	1.20	1.20	1.06	1.06	0.96	0.96	0.87	0.87	0.73	0.73	0.63	0.63	0.56	0.56	0.51	0.51	0.46	0.46
			28.0	28.0	28.0	28.0	28.0	28.0	28.0	28.0	28.0	28.0	28.0	28.0	28.0	28.0	28.0	28.0	28.0	28.0

Basis of calculation:

*Load according to EN 12812

Dead load $Q_1 = 0.40 \text{ kN/m}^2$
 Concrete load $Q_{2,b} = 24.5 \text{ kN/m}^3 \times d \text{ [m]}$
 Equivalent load: concreting $Q_4 = 0.10 \times Q_{2,b}$
 $0.75 \text{ kN/m}^2 \leq Q_4 \leq 1.75 \text{ kN/m}^2$
 Equivalent load: working mode $Q_{2,p} = 0.75 \text{ kN/m}^2$
 Total load $Q = Q_1 + Q_{2,b} + Q_{2,p} + Q_4$

Table values indicate the following:

2.77 perm. main beam spacing b [m]

28.0 actual prop load [kN]

- The deflection has been limited to $l/500$
- Main beam support at the girder node
- Cross girder as single-span girder

For cantilevers:

$c < 90 \text{ cm}$; $e = 30 \text{ cm}$
 $c \geq 90 \text{ cm}$; $e = 45 \text{ cm}$

c: width of main beam interior span or prop spacing
 e: length of cantilever

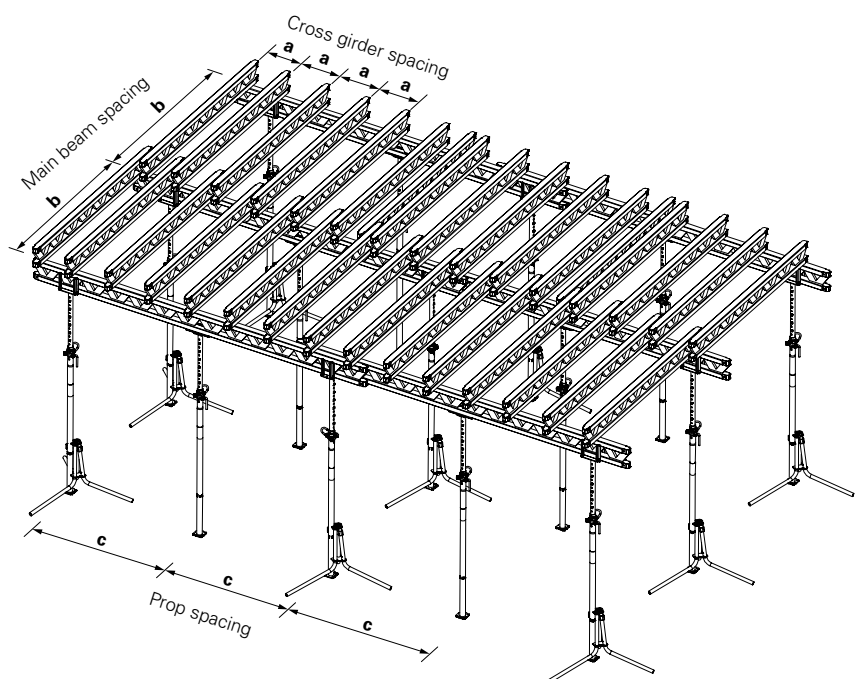
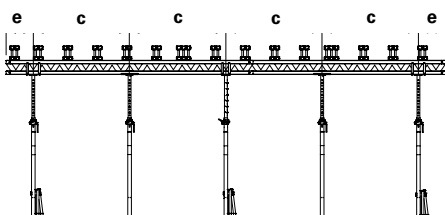

Slab thickness d [m]		0.10			0.12			0.14			0.16			0.18			0.20			
Load q* [kN/m²]		4.4			4.8			5.3			5.8			6.3			6.8			
Cross girder spacing a [m]		0.75	0.625	0.50	0.75	0.625	0.50	0.75	0.625	0.50	0.75	0.625	0.50	0.75	0.625	0.50	0.75	0.625	0.50	
Cantilever e [m]	0.25	0.50	3.21	3.41	3.67	3.04	3.23	3.48	2.91	3.09	3.33	2.79	2.97	3.20	2.70	2.86	3.09	2.61	2.77	2.99
			7.3	7.8	8.4	7.7	8.2	8.9	8.1	8.6	9.3	8.5	9.1	9.8	8.9	9.5	10.2	9.3	9.9	10.7
	0.375	0.75	3.21	3.41	3.67	3.04	3.23	3.48	2.91	3.09	3.33	2.79	2.97	3.20	2.70	2.86	3.09	2.61	2.77	2.99
			11.0	11.7	12.6	11.6	12.3	13.3	12.2	13.0	14.0	12.8	13.6	14.7	13.4	14.2	15.3	14.0	14.9	16.0
	0.50	1.00	3.21	3.41	3.67	3.04	3.23	3.48	2.91	3.09	3.33	2.79	2.97	3.20	2.70	2.86	3.09	2.61	2.77	2.99
			14.7	15.6	16.8	15.5	16.4	17.7	16.3	17.3	18.6	17.1	18.1	19.5	17.9	19.0	20.4	18.6	19.8	21.3
	0.50	1.25	3.21	3.41	3.67	3.04	3.23	3.46	2.91	3.09	3.14	2.79	2.88	2.88	2.66	2.66	2.66	2.46	2.46	2.46
			18.3	19.5	21.0	19.3	20.5	22.0	20.3	21.6	22.0	21.3	22.0	22.0	22.0	22.0	22.0	22.0	22.0	22.0
	0.50	1.50	3.21	3.21	3.21	2.89	2.89	2.89	2.62	2.62	2.62	2.40	2.40	2.40	2.21	2.21	2.21	2.05	2.05	2.05
			22.0	22.0	22.0	22.0	22.0	22.0	22.0	22.0	22.0	22.0	22.0	22.0	22.0	22.0	22.0	22.0	22.0	22.0
	0.50	1.75	2.75	2.75	2.75	2.47	2.47	2.47	2.25	2.25	2.25	2.06	2.06	2.06	1.90	1.90	1.90	1.76	1.76	1.76
			22.0	22.0	22.0	22.0	22.0	22.0	22.0	22.0	22.0	22.0	22.0	22.0	22.0	22.0	22.0	22.0	22.0	22.0
0.50	2.00	2.41	2.41	2.41	2.16	2.16	2.16	1.97	1.97	1.97	1.80	1.80	1.80	1.66	1.66	1.66	1.54	1.54	1.54	
		22.0	22.0	22.0	22.0	22.0	22.0	22.0	22.0	22.0	22.0	22.0	22.0	22.0	22.0	22.0	22.0	22.0	22.0	

Slab thickness d [m]		0.22			0.24			0.25			0.26			0.28			0.30			
Load q* [kN/m²]		7.3			7.8			8.0			8.3			8.8			9.3			
Cross girder spacing a [m]		0.75	0.625	0.50	0.625	0.50	0.40	0.625	0.50	0.40	0.625	0.50	0.40	0.625	0.50	0.40	0.625	0.50	0.40	
Cantilever e [m]	0.25	0.50	2.53	2.69	2.90	2.62	2.82	3.04	2.59	2.79	3.00	2.56	2.75	2.97	2.50	2.69	2.90	2.44	2.63	2.84
			9.7	10.3	11.1	10.7	11.5	12.4	10.9	11.7	12.6	11.1	12.0	12.9	11.5	12.4	13.3	11.9	12.8	13.8
	0.375	0.75	2.53	2.69	2.90	2.62	2.82	3.04	2.59	2.79	3.00	2.56	2.75	2.97	2.50	2.69	2.90	2.44	2.63	2.84
			14.5	15.5	16.7	16.1	17.3	18.6	16.4	17.6	19.0	16.6	17.9	19.3	17.2	18.6	20.0	17.8	19.2	20.7
	0.50	1.00	2.53	2.69	2.87	2.62	2.69	2.69	2.59	2.61	2.61	2.53	2.53	2.53	2.39	2.39	2.39	2.27	2.27	2.27
			19.4	20.6	22.0	21.4	22.0	22.0	21.8	22.0	22.0	22.0	22.0	22.0	22.0	22.0	22.0	22.0	22.0	22.0
	0.50	1.25	2.30	2.30	2.30	2.15	2.15	2.15	2.09	2.09	2.09	2.03	2.03	2.03	1.91	1.91	1.91	1.81	1.81	1.81
			22.0	22.0	22.0	22.0	22.0	22.0	22.0	22.0	22.0	22.0	22.0	22.0	22.0	22.0	22.0	22.0	22.0	22.0
	0.50	1.50	1.92	1.92	1.92	1.80	1.80	1.80	1.74	1.74	1.74	1.69	1.69	1.69	1.59	1.59	1.59	1.51	1.51	1.51
			22.0	22.0	22.0	22.0	22.0	22.0	22.0	22.0	22.0	22.0	22.0	22.0	22.0	22.0	22.0	22.0	22.0	22.0
	0.50	1.75	1.64	1.64	1.64	1.54	1.54	1.54	1.49	1.49	1.49	1.45	1.45	1.45	1.37	1.37	1.37	1.29	1.29	1.29
			22.0	22.0	22.0	22.0	22.0	22.0	22.0	22.0	22.0	22.0	22.0	22.0	22.0	22.0	22.0	22.0	22.0	22.0
0.50	2.00	1.44	1.44	1.44	1.35	1.35	1.35	1.31	1.31	1.31	1.27	1.27	1.27	1.20	1.20	1.20	1.13	1.13	1.13	
		22.0	22.0	22.0	22.0	22.0	22.0	22.0	22.0	22.0	22.0	22.0	22.0	22.0	22.0	22.0	22.0	22.0	22.0	22.0

Slab thickness d [m]		0.35	0.40	0.45	0.50	0.60	0.70	0.80	0.90	1.00										
Load q* [kN/m²]		10.6	11.9	13.3	14.6	17.3	20.0	22.5	25.0	27.4										
Cross girder spacing a [m]		0.50	0.40	0.50	0.40	0.50	0.40	0.50	0.40	0.50	0.40									
Cantilever e [m]	0.25	0.50	2.51	2.70	2.40	2.59	2.31	2.49	2.24	2.41	2.11	2.27	2.00	2.09	1.86	1.86	1.68	1.68	1.53	1.53
			13.9	15.0	15.0	16.2	16.1	17.4	17.2	18.5	19.2	20.6	21.0	22.0	22.0	22.0	22.0	22.0	22.0	22.0
	0.375	0.75	2.51	2.64	2.34	2.34	2.10	2.10	1.91	1.91	1.61	1.61	1.40	1.40	1.24	1.24	1.12	1.12	1.02	1.02
			20.9	22.0	22.0	22.0	22.0	22.0	22.0	22.0	22.0	22.0	22.0	22.0	22.0	22.0	22.0	22.0	22.0	22.0
	0.50	1.00	1.98	1.98	1.76	1.76	1.58	1.58	1.43	1.43	1.21	1.21	1.05	1.05	0.93	0.93	0.84	0.84	0.76	0.76
			22.0	22.0	22.0	22.0	22.0	22.0	22.0	22.0	22.0	22.0	22.0	22.0	22.0	22.0	22.0	22.0	22.0	22.0
	0.50	1.25	1.58	1.58	1.41	1.41	1.26	1.26	1.15	1.15	0.97	0.97	0.84	0.84	0.74	0.74	0.67	0.67	0.61	0.61
			22.0	22.0	22.0	22.0	22.0	22.0	22.0	22.0	22.0	22.0	22.0	22.0	22.0	22.0	22.0	22.0	22.0	22.0
	0.50	1.50	1.32	1.32	1.17	1.17	1.05	1.05	0.96	0.96	0.81	0.81	0.70	0.70	0.62	0.62	0.56	0.56	0.51	0.51
			22.0	22.0	22.0	22.0	22.0	22.0	22.0	22.0	22.0	22.0	22.0	22.0	22.0	22.0	22.0	22.0	22.0	22.0
0.50	1.75	1.13	1.13	1.00	1.00	0.90	0.90	0.82	0.82	0.69	0.69	0.60	0.60	0.53	0.53	0.48	0.48	0.44	0.44	
		22.0	22.0	22.0	22.0	22.0	22.0	22.0	22.0	22.0	22.0	22.0	22.0	22.0	22.0	22.0	22.0	22.0	22.0	22.0
0.50	2.00	0.99	0.99	0.88	0.88	0.79	0.79	0.72	0.72	0.60	0.60	0.52	0.52	0.47	0.47	0.42	0.42	0.38	0.38	
		22.0	22.0	22.0	22.0	22.0	22.0	22.0	22.0	22.0	22.0	22.0	22.0	22.0	22.0	22.0	22.0	22.0	22.0	22.0

Basis of calculation:

*Load according to EN 12812

Dead load $Q_1 = 0.40 \text{ kN/m}^2$
 Concrete load $Q_{2,b} = 24.5 \text{ kN/m}^3 \times d \text{ [m]}$
 Equivalent load: concreting $Q_4 = 0.10 \times Q_{2,b}$
 $0.75 \text{ kN/m}^2 \leq Q_4 \leq 1.75 \text{ kN/m}^2$
 Equivalent load: working mode $Q_{2,p} = 0.75 \text{ kN/m}^2$
 Total load $Q = Q_1 + Q_{2,b} + Q_{2,p} + Q_4$

Table values indicate the following:

2.61 perm. main beam spacing b [m]

22.0 actual prop load [kN]

- The deflection has been limited to $l/500$
- Cross girder as single-span girder

For cantilevers:

$c < 75 \text{ cm}$; $e = c/2 \text{ cm}$
 $c \geq 75 \text{ cm}$; $e = 50 \text{ cm}$

c: width of main beam interior span or prop spacing
 e: length of cantilever

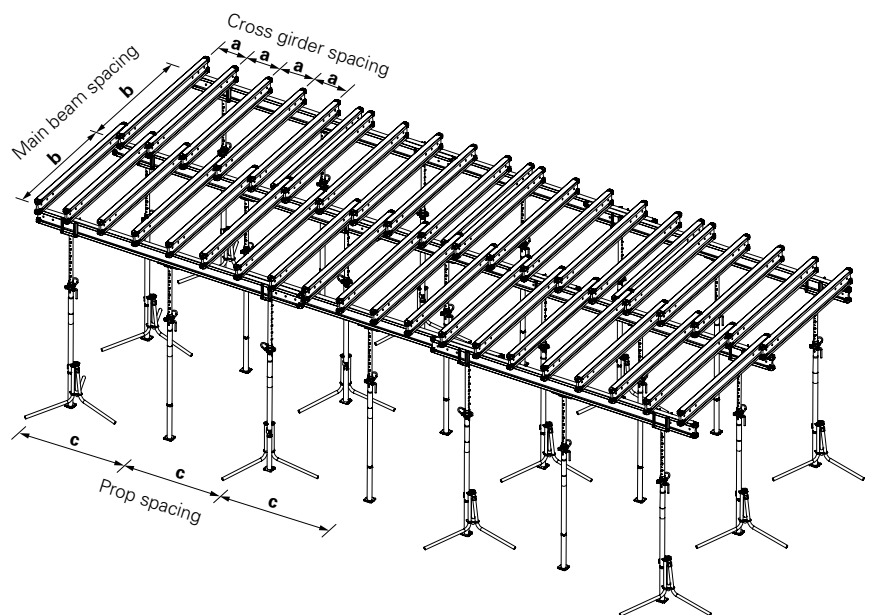
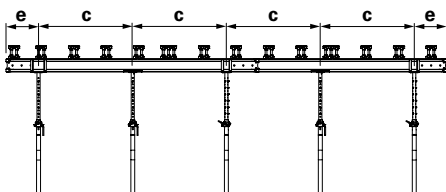

Slab thickness d [m]		0.10			0.12			0.14			0.16			0.18			0.20			
Load q* [kN/m²]		4.4			4.8			5.3			5.8			6.3			6.8			
Cross girder spacing a [m]		0.75	0.625	0.50	0.75	0.625	0.50	0.75	0.625	0.50	0.75	0.625	0.50	0.75	0.625	0.50	0.75	0.625	0.50	
Cantilever e [m]	0.30	0.60	3.99	4.24	4.57	3.79	4.03	4.34	3.62	3.85	4.14	3.48	3.70	3.98	3.36	3.57	3.84	3.25	3.45	3.72
			10.9	11.6	12.5	11.6	12.3	13.2	12.2	12.9	13.9	12.8	13.5	14.6	13.3	14.2	15.3	13.9	14.8	15.9
	0.45	0.90	3.99	4.24	4.57	3.79	4.03	4.34	3.62	3.85	4.14	3.48	3.70	3.98	3.36	3.57	3.84	3.25	3.45	3.72
			16.4	17.4	18.8	17.3	18.4	19.8	18.2	19.4	20.9	19.1	20.3	21.9	20.0	21.3	22.9	20.9	22.2	23.9
	0.45	1.20	3.99	4.24	4.57	3.79	4.03	4.34	3.62	3.85	4.14	3.48	3.70	3.98	3.36	3.57	3.84	3.25	3.45	3.72
			21.9	23.3	25.1	23.1	24.6	26.4	24.3	25.8	27.8	25.5	27.1	29.2	26.7	28.3	30.5	27.8	29.6	31.9
	0.45	1.50	3.99	4.24	4.57	3.79	4.03	4.34	3.62	3.85	4.14	3.48	3.70	3.98	3.36	3.57	3.84	3.25	3.45	3.72
			27.4	29.1	31.3	28.9	30.7	33.1	30.4	32.3	34.8	31.9	33.9	36.5	33.3	35.4	38.2	34.8	37.0	39.8
	0.45	1.80	3.99	4.24	4.57	3.79	4.03	4.34	3.62	3.85	4.14	3.48	3.70	3.98	3.36	3.57	3.84	3.25	3.45	3.72
			32.8	34.9	37.6	34.7	36.8	39.7	36.5	38.8	41.7	38.3	40.6	43.8	40.0	42.5	45.8	41.7	44.4	47.8
	0.45	2.10	3.99	4.24	4.57	3.79	4.03	4.34	3.62	3.85	4.14	3.48	3.70	3.98	3.36	3.57	3.84	3.25	3.45	3.72
			38.3	40.7	43.9	40.4	43.0	46.3	42.5	45.2	48.7	44.6	47.4	51.1	46.7	49.6	53.4	48.7	51.8	55.8

Slab thickness d [m]		0.22			0.24			0.25			0.26			0.28			0.30			
Load q* [kN/m²]		7.3			7.8			8.0			8.3			8.8			9.3			
Cross girder spacing a [m]		0.75	0.625	0.50	0.625	0.50	0.40	0.625	0.50	0.40	0.625	0.50	0.40	0.625	0.50	0.40	0.625	0.50	0.40	
Cantilever e [m]	0.30	0.60	3.15	3.35	3.61	3.26	3.51	3.79	3.22	3.47	3.74	3.18	3.43	3.69	3.11	3.35	3.61	3.04	3.28	3.53
			14.5	15.4	16.6	16.0	17.2	18.6	16.3	17.5	18.9	16.6	17.9	19.2	17.2	18.5	19.9	17.7	19.1	20.6
	0.45	0.90	3.15	3.35	3.61	3.26	3.51	3.79	3.22	3.47	3.74	3.18	3.43	3.69	3.11	3.35	3.61	3.04	3.28	3.53
			21.7	23.1	24.9	24.0	25.8	27.8	24.4	26.3	28.3	24.9	26.8	28.9	25.7	27.7	29.9	26.6	28.6	30.8
	0.45	1.20	3.15	3.35	3.61	3.26	3.51	3.79	3.22	3.47	3.74	3.18	3.43	3.69	3.11	3.35	3.61	3.04	3.28	3.53
			29.0	30.8	33.2	32.0	34.4	37.1	32.6	35.1	37.8	33.2	35.7	38.5	34.3	37.0	39.8	35.4	38.2	41.1
	0.45	1.50	3.15	3.35	3.61	3.26	3.51	3.79	3.22	3.47	3.74	3.18	3.43	3.69	3.11	3.35	3.61	3.04	3.28	3.53
			36.2	38.5	41.5	40.0	43.1	46.4	40.7	43.9	47.2	41.4	44.6	48.1	42.9	46.2	49.8	44.3	47.7	51.4
	0.45	1.80	3.15	3.35	3.61	3.26	3.51	3.79	3.22	3.47	3.69	3.18	3.43	3.58	3.11	3.35	3.38	3.04	3.20	3.20
			43.5	46.2	49.7	48.0	51.7	55.7	48.9	52.6	56.0	49.7	53.6	56.0	51.5	55.4	56.0	53.2	56.0	56.0
	0.45	2.10	3.15	3.35	3.48	3.26	3.26	3.26	3.16	3.16	3.16	3.07	3.07	3.07	2.90	2.90	2.90	2.75	2.75	2.75
			50.7	53.9	56.0	56.0	56.0	56.0	56.0	56.0	56.0	56.0	56.0	56.0	56.0	56.0	56.0	56.0	56.0	56.0

Slab thickness d [m]		0.35	0.40	0.45	0.50	0.60	0.70	0.80	0.90	1.00										
Load q* [kN/m²]		10.6		11.9		13.3		14.6		17.3		20.0		22.5		25.0		27.4		
Cross girder spacing a [m]		0.50	0.40	0.50	0.40	0.50	0.40	0.50	0.40	0.50	0.40	0.50	0.40	0.50	0.40	0.50	0.40	0.50	0.40	
Cantilever e [m]	0.30	0.60	3.12	3.36	2.99	3.22	2.88	3.10	2.77	3.00	2.54	2.83	2.37	2.64	2.23	2.49	2.08	2.37	1.90	2.26
			20.8	22.4	22.5	24.2	24.1	25.9	25.5	27.6	27.7	30.8	29.8	33.3	31.6	35.4	32.8	37.2	32.8	39.0
	0.45	0.90	3.12	3.36	2.99	3.22	2.88	3.10	2.77	3.00	2.54	2.83	2.37	2.64	2.23	2.49	2.08	2.37	1.90	2.16
			31.2	33.6	33.7	36.3	36.1	38.9	38.2	41.4	41.6	46.2	44.7	50.0	47.4	53.0	49.1	55.9	49.1	56.0
	0.45	1.20	3.12	3.36	2.99	3.22	2.88	3.10	2.77	3.00	2.54	2.57	2.22	2.22	1.98	1.98	1.78	1.78	1.62	1.62
			41.6	44.8	44.9	48.4	48.2	51.9	51.0	55.2	55.5	56.0	56.0	56.0	56.0	56.0	56.0	56.0	56.0	56.0
	0.45	1.50	3.12	3.36	2.98	2.98	2.68	2.68	2.43	2.43	2.05	2.05	1.78	1.78	1.58	1.58	1.43	1.43	1.30	1.30
			52.0	56.0	56.0	56.0	56.0	56.0	56.0	56.0	56.0	56.0	56.0	56.0	56.0	56.0	56.0	56.0	56.0	56.0
	0.45	1.80	2.80	2.80	2.48	2.48	2.23	2.23	2.03	2.03	1.71	1.71	1.48	1.48	1.32	1.32	1.19	1.19	1.08	1.08
			56.0	56.0	56.0	56.0	56.0	56.0	56.0	56.0	56.0	56.0	56.0	56.0	56.0	56.0	56.0	56.0	56.0	56.0
	0.45	2.10	2.40	2.40	2.13	2.13	1.91	1.91	1.74	1.74	1.47	1.47	1.27	1.27	1.13	1.13	1.02	1.02	0.93	0.93
			56.0	56.0	56.0	56.0	56.0	56.0	56.0	56.0	56.0	56.0	56.0	56.0	56.0	56.0	56.0	56.0	56.0	56.0

Basis of calculation:

*Load according to EN 12812

Dead load $Q_1 = 0.40 \text{ kN/m}^2$
 Concrete load $Q_{2,b} = 24.5 \text{ kN/m}^3 \times d \text{ [m]}$
 Equivalent load: concreting $Q_4 = 0.10 \times Q_{2,b}$
 $0.75 \text{ kN/m}^2 \leq Q_4 \leq 1.75 \text{ kN/m}^2$
 Equivalent load: working mode $Q_{2,p} = 0.75 \text{ kN/m}^2$
 Total load $Q = Q_1 + Q_{2,b} + Q_{2,p} + Q_4$

Table values indicate the following:

3.16 perm. main beam spacing b [m]

56.0 actual prop load [kN]

- The deflection has been limited to $l/500$
- Main beam support at the girder node
- Cross girder as single-span girder
- For prop loads < 28.0 kN,
1 x GT 24 as the main beam is sufficient.

For cantilevers:

$c < 90 \text{ cm}$; $e = 30 \text{ cm}$
 $c \geq 90 \text{ cm}$; $e = 45 \text{ cm}$

c: width of main beam interior span or prop spacing
 e: length of cantilever

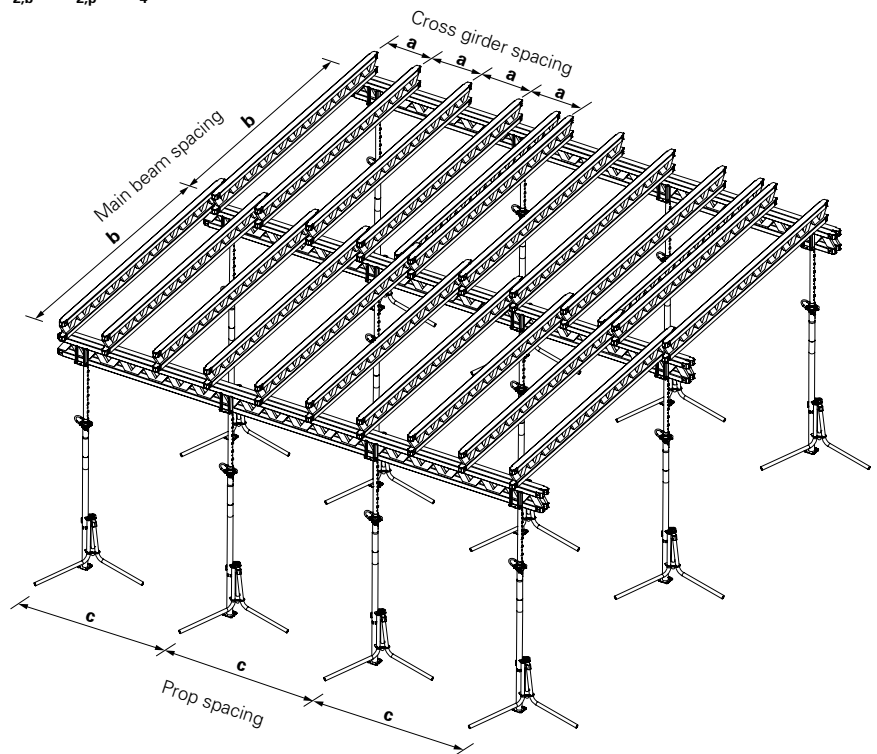
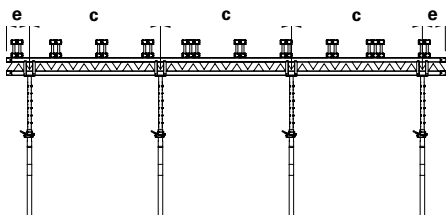

Slab thickness d [m]		0.10			0.12			0.14			0.16			0.18			0.20			
Load q* [kN/m²]		4.4			4.8			5.3			5.8			6.3			6.8			
Cross girder spacing a [m]		0.75	0.625	0.50	0.75	0.625	0.50	0.75	0.625	0.50	0.75	0.625	0.50	0.75	0.625	0.50	0.75	0.625	0.50	
Cantilever e [m]	0.25	0.50	3.21	3.41	3.67	3.04	3.23	3.48	2.91	3.09	3.33	2.79	2.97	3.20	2.70	2.86	3.09	2.61	2.77	2.99
			7.3	7.8	8.4	7.7	8.2	8.9	8.1	8.6	9.3	8.5	9.1	9.8	8.9	9.5	10.2	9.3	9.9	10.7
	0.375	0.75	3.21	3.41	3.67	3.04	3.23	3.48	2.91	3.09	3.33	2.79	2.97	3.20	2.70	2.86	3.09	2.61	2.77	2.99
			11.0	11.7	12.6	11.6	12.3	13.3	12.2	13.0	14.0	12.8	13.6	14.7	13.4	14.2	15.3	14.0	14.9	16.0
	0.50	1.00	3.21	3.41	3.67	3.04	3.23	3.48	2.91	3.09	3.33	2.79	2.97	3.20	2.70	2.86	3.09	2.61	2.77	2.99
			14.7	15.6	16.8	15.5	16.4	17.7	16.3	17.3	18.6	17.1	18.1	19.5	17.9	19.0	20.4	18.6	19.8	21.3
	0.50	1.25	3.21	3.41	3.67	3.04	3.23	3.48	2.91	3.09	3.33	2.79	2.97	3.20	2.70	2.86	3.09	2.61	2.77	2.99
			18.3	19.5	21.0	19.3	20.5	22.1	20.3	21.6	23.3	21.3	22.7	24.4	22.3	23.7	25.6	23.3	24.8	26.7
	0.50	1.50	3.21	3.41	3.67	3.04	3.23	3.48	2.91	3.09	3.33	2.79	2.97	3.20	2.70	2.86	3.09	2.61	2.77	2.99
			22.0	23.4	25.2	23.2	24.7	26.6	24.4	25.9	27.9	25.6	27.2	29.3	26.8	28.5	30.7	27.9	29.7	32.0
	0.50	1.75	3.21	3.41	3.67	3.04	3.23	3.48	2.91	3.09	3.33	2.79	2.97	3.20	2.70	2.86	3.09	2.61	2.77	2.99
			25.7	27.3	29.4	27.1	28.8	31.0	28.5	30.3	32.6	29.9	31.7	34.2	31.3	33.2	35.8	32.6	34.7	37.3
0.50	2.00	3.21	3.41	3.67	3.04	3.23	3.48	2.91	3.09	3.33	2.79	2.97	3.20	2.70	2.86	3.09	2.61	2.77	2.99	
		29.3	31.2	33.6	30.9	32.9	35.4	32.5	34.6	37.3	34.1	36.3	39.1	35.7	38.0	40.9	37.3	39.6	42.7	

Slab thickness d [m]		0.22			0.24			0.25			0.26			0.28			0.30			
Load q* [kN/m²]		7.3			7.8			8.0			8.3			8.8			9.3			
Cross girder spacing a [m]		0.75	0.625	0.50	0.625	0.50	0.40	0.625	0.50	0.40	0.625	0.50	0.40	0.625	0.50	0.40	0.625	0.50	0.40	
Cantilever e [m]	0.25	0.50	2.53	2.69	2.90	2.62	2.82	3.04	2.59	2.79	3.00	2.56	2.75	2.97	2.50	2.69	2.90	2.44	2.63	2.84
			9.7	10.3	11.1	10.7	11.5	12.4	10.9	11.7	12.6	11.1	12.0	12.9	11.5	12.4	13.3	11.9	12.8	13.8
	0.375	0.75	2.53	2.69	2.90	2.62	2.82	3.04	2.59	2.79	3.00	2.56	2.75	2.97	2.50	2.69	2.90	2.44	2.63	2.84
			14.5	15.5	16.7	16.1	17.3	18.6	16.4	17.6	19.0	16.6	17.9	19.3	17.2	18.6	20.0	17.8	19.2	20.7
	0.50	1.00	2.53	2.69	2.90	2.62	2.82	3.04	2.59	2.79	3.00	2.56	2.75	2.97	2.50	2.69	2.90	2.44	2.63	2.84
			19.4	20.6	22.2	21.4	23.1	24.8	21.8	23.5	25.3	22.2	23.9	25.8	23.0	24.7	26.7	23.7	25.6	27.5
	0.50	1.25	2.53	2.69	2.90	2.62	2.82	3.04	2.59	2.79	3.00	2.56	2.75	2.97	2.50	2.69	2.90	2.44	2.63	2.84
			24.2	25.8	27.8	26.8	28.8	31.1	27.3	29.4	31.6	27.7	29.9	32.2	28.7	30.9	33.3	29.7	32.0	34.4
	0.50	1.50	2.53	2.69	2.90	2.62	2.82	3.04	2.59	2.79	3.00	2.56	2.75	2.97	2.50	2.69	2.90	2.44	2.63	2.84
			29.1	30.9	33.3	32.1	34.6	37.3	32.7	35.2	37.9	33.3	35.9	38.6	34.5	37.1	40.0	35.6	38.3	41.3
	0.50	1.75	2.53	2.69	2.90	2.62	2.82	3.04	2.59	2.79	2.98	2.56	2.75	2.90	2.50	2.69	2.73	2.44	2.59	2.59
			33.9	36.1	38.9	37.5	40.4	43.5	38.2	41.1	44.0	38.8	41.8	44.0	40.2	43.3	44.0	41.5	44.0	44.0
0.50	2.00	2.53	2.69	2.87	2.62	2.69	2.69	2.59	2.61	2.61	2.53	2.53	2.53	2.39	2.39	2.39	2.27	2.27	2.27	
		38.8	41.2	44.0	42.8	44.0	44.0	43.6	44.0	44.0	44.0	44.0	44.0	44.0	44.0	44.0	44.0	44.0	44.0	

Slab thickness d [m]		0.35	0.40	0.45	0.50	0.60	0.70	0.80	0.90	1.00										
Load q* [kN/m ²]		10.6		11.9		13.3		14.6		17.3		20.0		22.5		25.0		27.4		
Cross girder spacing a [m]		0.50	0.40	0.50	0.40	0.50	0.40	0.50	0.40	0.50	0.40	0.50	0.40	0.50	0.40	0.50	0.40	0.50	0.40	
Cantilever e [m]	0.25	0.50	2.51	2.70	2.40	2.59	2.31	2.49	2.24	2.41	2.11	2.27	2.00	2.16	1.89	2.07	1.76	1.99	1.61	1.91
			13.9	15.0	15.0	16.2	16.1	17.4	17.2	18.5	19.2	20.6	21.0	22.7	22.3	24.4	23.1	26.1	23.1	27.5
	0.375	0.75	2.51	2.70	2.40	2.59	2.31	2.49	2.24	2.41	2.11	2.27	2.00	2.16	1.89	2.07	1.76	1.99	1.61	1.91
			20.9	22.5	22.6	24.3	24.2	26.0	25.7	27.7	28.7	31.0	31.5	34.0	33.4	36.6	34.7	39.1	34.7	41.2
	0.50	1.00	2.51	2.70	2.40	2.59	2.31	2.49	2.24	2.41	2.11	2.27	2.00	2.09	1.86	1.86	1.68	1.68	1.53	1.53
			27.8	30.0	30.1	32.4	32.2	34.7	34.3	37.0	38.3	41.3	42.0	44.0	44.0	44.0	44.0	44.0	44.0	44.0
	0.50	1.25	2.51	2.70	2.40	2.59	2.31	2.49	2.24	2.29	1.94	1.94	1.67	1.67	1.49	1.49	1.34	1.34	1.22	1.22
			34.8	37.5	37.6	40.5	40.3	43.4	42.9	44.0	44.0	44.0	44.0	44.0	44.0	44.0	44.0	44.0	44.0	44.0
	0.50	1.50	2.51	2.64	2.34	2.34	2.10	2.10	1.91	1.91	1.61	1.61	1.40	1.40	1.24	1.24	1.12	1.12	1.02	1.02
			41.8	44.0	44.0	44.0	44.0	44.0	44.0	44.0	44.0	44.0	44.0	44.0	44.0	44.0	44.0	44.0	44.0	44.0
	0.50	1.75	2.26	2.26	2.01	2.01	1.80	1.80	1.64	1.64	1.38	1.38	1.20	1.20	1.06	1.06	0.96	0.96	0.87	0.87
			44.0	44.0	44.0	44.0	44.0	44.0	44.0	44.0	44.0	44.0	44.0	44.0	44.0	44.0	44.0	44.0	44.0	44.0
0.50	2.00	1.98	1.98	1.76	1.76	1.58	1.58	1.43	1.43	1.21	1.21	1.05	1.05	0.93	0.93	0.84	0.84	0.76	0.76	
		44.0	44.0	44.0	44.0	44.0	44.0	44.0	44.0	44.0	44.0	44.0	44.0	44.0	44.0	44.0	44.0	44.0	44.0	44.0

Basis of calculation:

*Load according to EN 12812

Dead load $Q_1 = 0.40 \text{ kN/m}^2$
 Concrete load $Q_{2,b} = 24.5 \text{ kN/m}^3 \times d$
 Equivalent load: concreting $Q_4 = 0.10 \times Q_{2,b}$
 $0.75 \text{ kN/m}^2 \leq Q_4 \leq 1.75 \text{ kN/m}^2$
 Equivalent load: working mode $Q_{2,p} = 0.75 \text{ kN/m}^2$
 Total load $Q = Q_1 + Q_{2,b} + Q_{2,p} + Q_4$

Table values indicate the following:

2.61 perm. main beam spacing b [m]

44.0 actual prop load [kN]

- The deflection has been limited to $l/500$
- Cross girder as single-span girder
- For prop loads < 22.0 kN, 1 x VT 20 as the main beam is sufficient.

For cantilevers:

$c < 75 \text{ cm}$; $e = c/2 \text{ cm}$

$c \geq 75 \text{ cm}$; $e = 50 \text{ cm}$

c: width of main beam interior span or prop spacing

e: length of cantilever

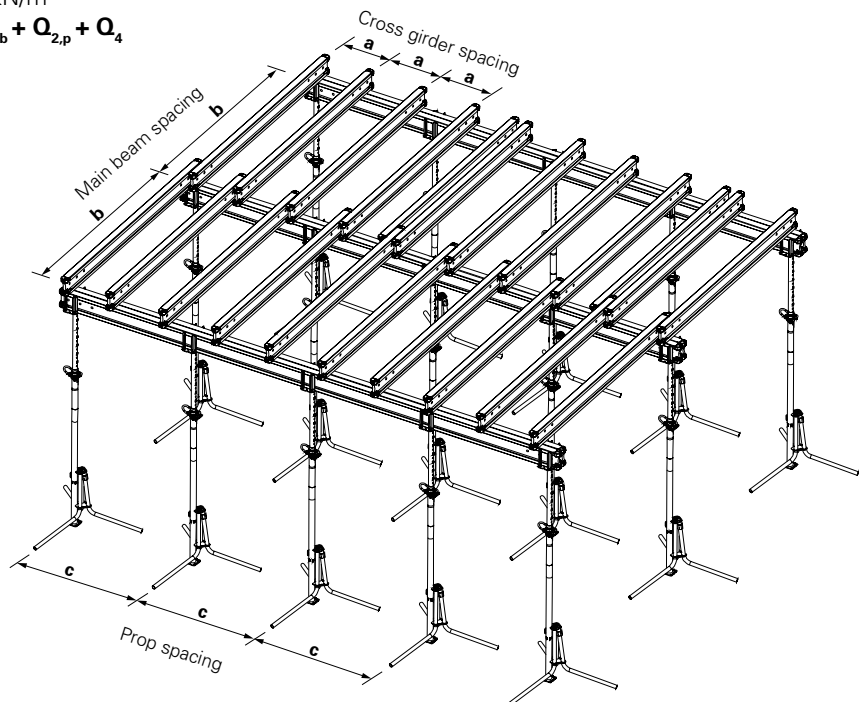
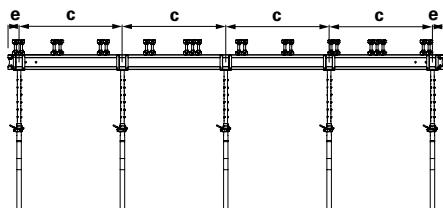

Slab Props PEP

PEP Ergo B

Slab Props PEP

Permissible prop load [kN]

Extension length [m]	PEP Ergo B-300		PEP Ergo B-350	
	L = 1.97 – 3.00 m		L = 2.25 – 3.50 m	
	Lower outer tube	Lower inner tube	Lower outer tube	Lower inner tube
2.00	30.8	30.8		
2.10	29.8	30.8		
2.20	27.0	30.8		
2.30	24.6	30.8	30.8	28.6
2.40	23.0	30.8	28.6	28.6
2.50	21.5	30.8	25.5	28.6
2.60	20.3	29.5	23.1	28.4
2.70	19.3	27.5	21.3	28.0
2.80	18.3	24.8	19.8	27.4
2.90	16.9	22.3	18.6	26.1
3.00	15.6	20.2	17.5	24.4
3.10			16.3	22.8
3.20			15.2	20.8
3.30			14.3	19.0
3.40			13.2	17.4
3.50			12.4	15.7

Notes:

- PERI PEP Ergo B-300 and PEP Ergo B-350 props meet the load-bearing capacity requirements of Prop Class B as stipulated in DIN EN 1065.
- General Technical Approval Z-8.311-934 issued by the German Institute for Structural Engineering.

Slab Props PEP

PEP Ergo B with Base MP 50

Permissible prop load [kN]

Overall height [m] (prop extension + 50 cm)	PEP Ergo B-300		PEP Ergo B-350	
	L = 1.97 – 3.00 m		L = 2.25 – 3.50 m	
	Lower outer tube	Lower inner tube	Lower outer tube	Lower inner tube
2.50	30.8	30.8		
2.60	29.3	30.8		
2.70	26.3	30.8		
2.80	23.8	30.8	30.8	30.5
2.90	21.8	30.8	28.1	30.2
3.00	20.4	28.3	25.0	29.6
3.10	19.2	25.1	22.4	28.9
3.20	18.1	22.5	20.6	27.5
3.30	16.9	20.4	19.0	25.0
3.40	15.6	18.6	17.7	22.6
3.50	14.3	16.9	16.5	20.5
3.60			15.2	18.7
3.70			14.1	16.9
3.80			13.1	15.0
3.90			12.2	13.4
4.00			11.2	11.9

Slab Props PEP

PEP Ergo D

Permissible prop load [kN]

Extension length [m]	PEP Ergo D-150 L = 0.98 – 1.50 m		PEP Ergo D-250 L = 1.47 – 2.50 m		PEP Ergo D-300 + L = 1.79 – 3.00 m	
	Lower outer tube	Lower inner tube	Lower outer tube	Lower inner tube	Lower outer tube	Lower inner tube
1.00	30.8	30.8				
1.10	30.8	30.8				
1.20	30.8	30.8				
1.30	30.8	30.8				
1.40	28.5	30.8				
1.50	26.4	30.8	35.0	35.0		
1.60			35.0	35.0		
1.70			32.9	35.0		
1.80			30.7	35.0	35.0	35.0
1.90			29.1	35.0	35.0	35.0
2.00			28.1	35.0	35.0	35.0
2.10			27.3	35.0	35.0	35.0
2.20			26.5	34.1	35.0	35.0
2.30			25.7	32.3	33.5	35.0
2.40			24.3	29.4	31.5	34.0
2.50			22.4	26.3	30.2	32.8
2.60					28.3	31.4
2.70					26.2	29.2
2.80					24.2	26.9
2.90					22.4	24.9
3.00					20.6	22.7

Notes:

- The PERI PEP Ergo D-150, PEP Ergo D-250, PEP Ergo D-350, PEP Ergo D-400 and PEP Ergo D-500 Props meet the load-bearing capacity requirements of prop class D of DIN EN 1065.
- The PEP Ergo D-250 Prop also fulfils the prop class B requirements of DIN EN 1065.
- General Technical Approval Z-8.311-934 for PERI PEP Ergo D-150, PEP Ergo D-250 and PEP Ergo D-300 +.
- General Technical Approval Z-8.311-941 for PERI PEP Ergo D-350 +, PEP Ergo D-400 and PEP Ergo D-500.

Slab Props PEP

PEP Ergo D

Permissible prop load [kN]

Extension length [m]	PEP Ergo D-350 + L = 2.08 – 3.50 m		PEP Ergo D-400 L = 2.51 – 4.00 m		PEP Ergo D-500 L = 3.26 – 5.00 m	
	Lower outer tube	Lower inner tube	Lower outer tube	Lower inner tube	Lower outer tube	Lower inner tube
2.10	40.0	40.0				
2.20	40.0	40.0				
2.30	40.0	40.0				
2.40	39.7	40.0				
2.50	36.9	40.0				
2.60	34.7	40.0	40.0	40.0		
2.70	32.9	40.0	40.0	40.0		
2.80	31.6	40.0	40.0	40.0		
2.90	30.3	40.0	40.0	40.0		
3.00	29.2	39.1	40.0	40.0		
3.10	27.2	35.4	37.7	40.0		
3.20	25.4	32.1	35.7	40.0		
3.30	23.7	29.4	33.9	40.0	40.0	40.0
3.40	22.1	27.0	32.5	40.0	40.0	40.0
3.50	20.7	24.7	31.0	39.7	40.0	40.0
3.60			29.0	36.4	40.0	40.0
3.70			27.0	33.3	40.0	40.0
3.80			25.2	30.7	40.0	40.0
3.90			23.5	28.2	40.0	40.0
4.00			21.8	26.0	40.0	40.0
4.10					39.3	40.0
4.20					36.5	40.0
4.30					34.0	39.2
4.40					31.8	37.0
4.50					29.9	34.6
4.60					28.1	32.4
4.70					26.4	30.4
4.80					24.8	28.5
4.90					23.4	26.8
5.00					21.8	25.3

Notes:

- The PERI PEP Ergo D-150, PEP Ergo D-250, PEP Ergo D-350, PEP Ergo D-400 and PEP Ergo D-500 Props meet the load-bearing capacity requirements of prop class D of DIN EN 1065.
- The PEP Ergo D-250 Prop also fulfils the prop class B requirements of DIN EN 1065.
- General Technical Approval Z-8.311-934 for PERI PEP Ergo D-150, PEP Ergo D-250 and PEP Ergo D-300 +.
- General Technical Approval Z-8.311-941 for PERI PEP Ergo D-350 +, PEP Ergo D-400 and PEP Ergo D-500.

Slab Props PEP

PEP Ergo E

Permissible prop load [kN]

Extension length [m]	PEP Ergo E-300 + L = 1.79 – 3.00 m		PEP Ergo E-350 + L = 2.08 – 3.50 m		PEP Ergo E-400 L = 2.51 – 4.00 m	
	Lower outer tube	Lower inner tube	Lower outer tube	Lower inner tube	Lower outer tube	Lower inner tube
1.80	50.4	50.4				
1.90	50.4	50.4				
2.00	50.4	50.4				
2.10	50.4	50.4	50.4	50.4		
2.20	50.4	50.4	50.4	50.4		
2.30	50.4	50.4	50.4	50.4		
2.40	47.3	50.4	50.4	50.4		
2.50	45.6	50.4	50.4	50.4		
2.60	44.5	50.4	50.4	50.4	50.4	50.4
2.70	43.3	50.4	48.5	50.4	50.4	50.4
2.80	41.8	50.4	46.4	50.4	50.4	50.4
2.90	40.3	48.0	44.5	50.4	50.4	50.4
3.00	37.5	43.0	43.0	50.4	50.4	50.4
3.10			41.5	50.4	50.4	50.4
3.20			38.7	46.1	50.4	50.4
3.30			36.0	41.9	50.4	50.4
3.40			33.3	38.2	50.4	50.4
3.50			30.9	34.9	48.5	50.4
3.60					46.0	50.4
3.70					42.7	48.4
3.80					39.7	44.7
3.90					36.9	41.1
4.00					34.1	37.7

Notes:

- The props PERI PEP Ergo E-300 +, PEP Ergo D-350 + and PEP Ergo E-400 fulfil the Prop Class E load-bearing capacity requirements of DIN EN 1065.
- General Technical Approval Z-8.311-941 of the German Institute for Structural Engineering (DIBt).

Slab Props PEP PEP Alpha D

Permissible prop load [kN]

Length in mm	PEP Alpha D-300		PEP Alpha D-350	
	Lower outer tube F_{max} (kN)	Lower inner tube F_{max} (kN)	Lower outer tube F_{max} (kN)	Lower inner tube F_{max} (kN)
1700	36.1	36.1		
1800	36.1	36.1		
1900	36.1	36.1		
2000	36.1	36.1	36.1	36.1
2100	35.6	36.1	36.1	36.1
2200	33.8	36.1	36.1	36.1
2300	32.1	36.1	36.1	36.1
2400	30.9	36.1	36.1	36.1
2500	29.7	35.2	36.1	36.1
2600	27.5	33.2	35.6	36.1
2700	25.5	30.6	33.9	36.1
2800	23.6	28.1	32.7	36.1
2900	21.9	25.8	31.2	36.1
3000	20.6	23.5	29.1	36.1
3100			27.3	34.2
3200			25.5	31.4
3300			23.7	28.7
3400			22.1	26.3
3500			20.6	24.2



The props PEP Alpha D-300 and PEP Alpha D-350 fulfil the load-bearing capacity requirements of DIN EN 1065.

Slab Props PEP

PEP 20

Permissible prop load [kN]

Extension length [m]	PEP 20 N 260*		PEP 20-300		PEP 20-350		PEP 20-400		PEP 20-500	
	L = 1.51 – 2.60 m		L = 1.71 – 3.00 m		L = 1.96 – 3.50 m		L = 2.21 – 4.00 m		L = 2.71 – 5.00 m	
	Lower outer tube	Lower inner tube	Lower outer tube	Lower inner tube	Lower outer tube	Lower inner tube	Lower outer tube	Lower inner tube	Lower outer tube	Lower inner tube
1.60	35.0	35.0								
1.70	35.0	35.0								
1.80	35.0	35.0	36.4	36.4						
1.90	35.0	35.0	36.4	36.4						
2.00	33.5	35.0	36.1	36.4	36.4	36.4				
2.10	31.9	35.0	33.2	36.4	36.4	36.4				
2.20	30.9	35.0	31.4	36.4	36.4	36.4				
2.30	29.8	35.0	29.9	36.4	36.4	36.4	36.4	36.4		
2.40	28.6	35.0	28.7	36.4	36.4	36.4	36.4	36.4		
2.50	27.1	32.9	27.7	36.4	36.4	36.4	36.4	36.4		
2.60	24.8	29.4	26.9	36.3	34.8	36.4	36.4	36.4		
2.70			25.7	32.7	33.4	36.4	36.4	36.4		
2.80			24.0	29.3	32.1	36.4	36.4	36.4	36.4	36.4
2.90			22.3	26.5	31.1	36.4	36.4	36.4	36.4	36.4
3.00			20.5	23.9	30.1	36.4	36.4	36.4	36.4	36.4
3.10					28.3	35.7	34.6	36.4	36.4	36.4
3.20					26.5	32.5	33.5	36.4	36.4	36.4
3.30					24.8	29.7	32.1	36.4	36.4	36.4
3.40					23.1	27.2	30.5	36.4	36.4	36.4
3.50					21.3	24.8	28.7	34.9	36.4	36.4
3.60							26.9	32.1	36.4	36.4
3.70							25.3	29.8	36.4	36.4
3.80							23.7	27.6	36.4	36.4
3.90							22.3	25.5	36.4	36.4
4.00							20.7	23.5	35.3	36.4
4.10									33.3	36.4
4.20									31.5	36.4
4.30									29.8	35.0
4.40									28.2	32.9
4.50									26.8	30.8
4.60									25.3	28.9
4.70									24.1	27.2
4.80									22.8	25.7
4.90									21.5	24.1
5.00									20.3	22.1

All PEP 20 Props conform to DIN EN 1065 Class D, i.e. the permissible prop load for all extension lengths is at least 20 kN.

When using PERI Slab Tables, the permissible load for all PEP 20 Props is a minimum of 30 kN over the entire extension length due to the clamping in the Table Swivel Head or UNIportal Head.

*For the N prop, use of the inner tube at the bottom is only possible with PERI Slab Tables or SKYDECK (bolted head).

Slab Props PEP

PEP 20 with Base MP 50

Permissible prop load [kN]

Overall height [m] (prop extension + 50 cm)	PEP 20 N 260*		PEP 20-300		PEP 20-350		PEP 20-400		PEP 20-500	
	L = 1.51 – 2.60 m		L = 1.71 – 3.00 m		L = 1.96 – 3.50 m		L = 2.21 – 4.00 m		L = 2.71 – 5.00 m	
	Lower outer tube	Lower inner tube	Lower outer tube	Lower inner tube	Lower outer tube	Lower inner tube	Lower outer tube	Lower inner tube	Lower outer tube	Lower inner tube
2.10	36.4	36.4								
2.20	36.4	36.4								
2.30	36.4	36.4	36.4	36.4						
2.40	34.2	36.4	36.4	36.4						
2.50	31.9	36.4	34.9	36.4	36.4	36.4				
2.60	30.4	36.4	31.8	36.4	36.4	36.4				
2.70	28.7	36.4	29.6	36.4	36.4	36.4				
2.80	27.3	34.7	27.8	36.4	36.4	36.4	36.4	36.4		
2.90	26.3	30.7	26.4	35.8	36.4	36.4	36.4	36.4		
3.00	24.5	27.5	25.2	32.1	35.0	36.4	36.4	36.4		
3.10	22.2	24.7	24.2	28.8	32.9	36.4	36.4	36.4		
3.20			23.1	26.3	31.1	36.4	36.4	36.4		
3.30			21.4	23.9	29.7	36.4	36.4	36.4	36.4	36.4
3.40			19.9	21.8	28.4	34.2	35.7	36.4	36.4	36.4
3.50			18.1	19.8	27.0	30.7	33.9	36.4	36.4	36.4
3.60					25.3	28.6	32.3	36.4	36.4	36.4
3.70					23.6	26.1	30.8	35.3	36.4	36.4
3.80					22.0	24.2	29.1	32.7	36.4	36.4
3.90					20.4	22.5	27.3	30.0	36.4	36.4
4.00					18.9	20.7	25.5	27.8	36.4	36.4
4.10							23.9	26.1	36.4	36.4
4.20							22.4	24.2	36.4	36.4
4.30							21.0	22.8	35.6	36.4
4.40							19.7	21.2	33.6	36.4
4.50							18.3	19.7	31.6	34.2
4.60									29.3	32.1
4.70									28.0	30.0
4.80									26.5	28.4
4.90									25.1	26.8
5.00									23.8	25.4
5.10									22.6	24.0
5.20									21.4	22.7
5.30									20.3	21.6
5.40									19.1	20.4
5.50									18.1	19.1

*For the N prop, use of the inner tube at the bottom is only possible with PERI Slab Tables or SKYDECK (bolted head).

Slab Props PEP

PEP 30



Permissible prop load [kN]

Extension length [m]	PEP 30-150 L = 0.96 – 1.50 m		PEP 30-250 L = 1.46 – 2.50 m		PEP 30-300 L = 1.71 – 3.00 m		PEP 30-350 L = 1.96 – 3.50 m		PEP 30-400 L = 2.21 – 4.00 m	
	Lower outer tube	Lower inner tube	Lower outer tube	Lower inner tube	Lower outer tube	Lower inner tube	Lower outer tube	Lower inner tube	Lower outer tube	Lower inner tube
1.00	36.4	36.4								
1.10	36.4	36.4								
1.20	36.4	36.4								
1.30	35.9	36.4								
1.40	35.3	36.4								
1.50	34.5	36.4	42.9	42.9						
1.60			42.9	42.9						
1.70			42.9	42.9						
1.80			42.1	42.9	42.9	42.9				
1.90			39.7	42.9	42.9	42.9				
2.00			37.9	42.9	42.9	42.9	45.5	45.5		
2.10			36.4	42.9	42.9	42.9	45.5	45.5		
2.20			35.5	42.9	42.9	42.9	45.5	45.5		
2.30			34.3	41.5	42.9	42.9	45.5	45.5	41.5	41.5
2.40			33.1	38.7	42.7	42.9	45.5	45.5	41.5	41.5
2.50			31.0	35.9	41.1	42.9	45.5	45.5	41.5	41.5
2.60					40.0	42.9	45.5	45.5	41.5	41.5
2.70					38.5	42.9	45.5	45.5	41.5	41.5
2.80					36.9	41.6	45.5	45.5	41.5	41.5
2.90					34.2	38.3	45.0	45.5	41.5	41.5
3.00					31.3	34.8	43.6	45.5	41.5	41.5
3.10							41.4	44.2	41.5	41.5
3.20							38.7	42.1	41.5	41.5
3.30							36.1	38.7	41.5	41.5
3.40							33.3	35.7	41.5	41.5
3.50							30.7	32.5	41.5	41.5
3.60									41.5	41.5
3.70									41.3	41.5
3.80									38.5	41.3
3.90									35.9	38.1
4.00									33.2	34.9

All PEP 30 Props conform to DIN EN 1065 Class E, i.e. the permissible prop load for all extension lengths is at least 30 kN.

When using PERI Slab Tables, the permissible load for all PEP 30 Props is a minimum of 40 kN (PEP 30-150 = 35 kN) over the entire extension range due to the clamping in the Table Swivel Head or UNIPORTAL Head.

Slab Props PEP

PEP 30 with Base MP 50

Permissible prop load [kN]

Overall height [m] (prop extension + 50 cm)	PEP 30-250 L = 1.46 – 2.50 m		PEP 30-300 L = 1.71 – 3.00 m		PEP 30-350 L = 1.96 – 3.50 m		PEP 30-400 L = 2.21 – 4.00 m	
	Lower outer tube	Lower inner tube	Lower outer tube	Lower inner tube	Lower outer tube	Lower inner tube	Lower outer tube	Lower inner tube
2.00	42.9	42.9						
2.10	42.9	42.9						
2.20	42.9	42.9						
2.30	40.1	42.9	42.9	42.9				
2.40	37.2	42.9	42.9	42.9				
2.50	35.0	42.9	42.9	42.9	45.4	45.4		
2.60	33.2	42.3	42.9	42.9	45.4	45.4		
2.70	31.8	39.8	42.9	42.9	45.4	45.4		
2.80	30.6	36.4	41.6	42.9	45.4	45.4	41.5	41.5
2.90	28.4	32.3	39.5	42.9	45.4	45.4	41.5	41.5
3.00	26.7	28.5	37.6	42.5	45.4	45.4	41.5	41.5
3.10			36.2	41.2	45.4	45.4	41.5	41.5
3.20			33.9	37.9	45.1	45.4	41.5	41.5
3.30			32.1	34.2	43.0	45.4	41.5	41.5
3.40			29.4	31.2	40.0	43.0	41.5	41.5
3.50			26.9	27.9	38.2	40.9	41.5	41.5
3.60					35.8	37.6	41.5	41.5
3.70					33.4	34.5	41.5	41.5
3.80					30.9	31.8	41.5	41.5
3.90					28.6	29.6	43.1	41.5
4.00					26.3	27.1	40.6	42.1
4.10							37.8	39.1
4.20							35.3	36.2
4.30							33.0	33.9
4.40							30.8	31.4
4.50							28.4	29.0

Slab Props MULTIPROP

MULTIPROP 250, 350, 480, 625 with Base MP 50

Permissible prop load [kN]

Overall height [m] (prop extension + 50 cm)	MP 250 + MP 50 L = 1.95 – 3.00 m		MP 350 + MP 50 L = 2.45 – 4.00 m		MP 480 + MP 50 L = 3.10 – 5.30 m		MP 625 + MP 50 L = 4.80 – 6.75 m	
	Lower outer tube	Lower inner tube	Lower outer tube	Lower inner tube	Lower outer tube	Lower inner tube	Lower outer tube	Lower inner tube
2.25	76.6	73.6						
2.30	74.5	72.9						
2.40	72.4	72.1						
2.50	66.1	69.8	87.6	84.2				
2.60	63.3	67.7	83.8	82.9				
2.70	60.5	65.6	79.9	81.7				
2.80	57.7	63.1	76.1	80.5				
2.90	55.1	60.1	70.0	77.0				
3.00	52.4	57.1	63.9	73.5				
3.10			60.8	70.6	76.8	73.3		
3.20			57.6	67.6	74.4	72.8		
3.30			55.2	64.7	71.9	72.3		
3.40			52.7	61.8	69.4	71.8		
3.50			50.8	59.1	67.0	71.3		
3.60			48.8	56.4	62.6	70.0		
3.70			46.9	52.2	58.2	68.7		
3.80			45.0	48.0	53.9	67.4		
3.90			41.8	43.9	51.2	62.9		
4.00			38.5	39.8	48.6	58.4		
4.10					45.9	53.9		
4.20					43.9	50.1		
4.30					41.9	46.3		
4.40					39.8	42.5		
4.50					37.7	40.0		
4.60					35.5	37.5		
4.70					33.3	35.0		
4.80					31.7	33.2	48.7	44.5
4.90					30.0	31.4	47.5	44.4
5.00					28.4	29.6	46.2	44.3
5.10					26.7	27.8	44.5	43.1
5.20					25.1	26.0	42.8	41.8
5.30					23.4	24.2	41.1	40.4
5.40							40.1	39.6
5.50							37.3	37.2
5.60							35.3	35.6
5.70							33.3	34.0
5.80							31.5	32.5
5.90							30.6	31.7
6.00							28.1	29.5
6.10							26.7	28.1
6.20							25.3	26.7
6.30							24.1	25.4
6.40							23.5	24.8
6.50							21.8	22.9
6.60							20.8	21.7
6.70							19.8	20.6
6.75							19.3	20.0

Note:

To release loads > 60 kN we recommend using the Wingnut Spanner HD, art. no. 022027.

Beam Beam Formwork UZ

Beam Formwork UZ

Permissible influence width EB [m]
for UZ Beam Bracket 40 depending
on the beam height and slab thick-
ness

Slab thickness d [m]	Beam height h [m]											
	0.30		0.40		0.50		0.60		0.70		0.80	
	Version		Version		Version		Version		Version		Version	
	1 1 x GT 24	2 2 x VT 20	1 1 x GT 24	2 2 x VT 20	1 2 x GT 24	2 2 x VT 20	1 2 x GT 24	2 2 x VT 20	1 2 x GT 24	2 3 x VT 20	1 2 x GT 24	2 3 x VT 20
0	2.01	4.21	1.74	3.59	1.57	3.14	1.45	2.80	1.36	2.60	*1.29	*1.85
0.20	2.05	4.56	1.91	3.30	1.77	2.69	1.64	1.95	*1.35	*1.42	*1.02	*1.07
0.25	1.83	4.00	1.71	2.51	1.62	2.36	1.55	1.77	*1.23	*1.29	*0.94	*0.98
0.30	1.77	3.58	1.66	2.34	1.58	2.10	1.51	1.61	*1.13	*1.19	*0.86	*0.90
0.35	1.71	3.30	1.62	2.06	1.54	1.88	1.40	1.45	*1.04	*1.09	*0.77	*0.83

The values relate to the load-bearing capacity of the UZ Beam Bracket 40, the vertical 8 x 8 cm squared timber used and the secondary beams as they are shown in the drawings.

Depending on the formlining used, additional secondary beams may be required.

Separate structural calculations must be provided to show that the sub-structure can carry all resulting loads.

The equivalent load (V/100) acting horizontally and the pressures arising on one side (e.g. the edge beam) are to be accommodated by suitable means provided by the contractor.

Version 1:
Side plate with 1 or 2 Girders GT 24
(vertical)

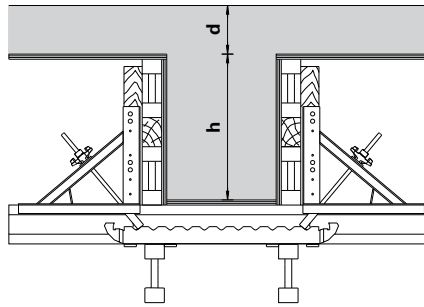

The maximum deflection is $l/500$
*) vertical squared timber in the UZ Beam Bracket
40 10 x 8 cm! (instead of 8 x 8 cm)

Version 2:
Side plate with 2 or 3 Girders VT 20
(horizontal)

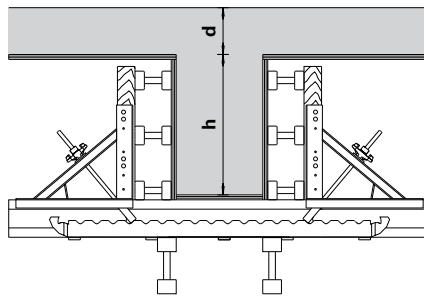

Version 3:
Lining of the formwork base

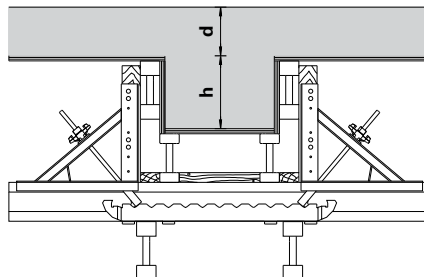

d = slab thickness
h = beam height

Beam AW Slab Stopend Angle

AW Slab Stopend Angle

Permissible influence width [m] for
AW Slab Stopend Angle depending
on the slab thickness, beam height
and fixing method

Substructure		Height of side formwork h [m]															
		0.20				0.25				0.30				0.35			
		nailed onto		clamped to		nailed onto		clamped to		nailed onto		clamped to		nailed onto		clamped to	
Slab thickness d [m]	SKYDECK*	Formlining 21 mm	Squared timber girder	Squared timber girder	SKYDECK*	Formlining 21 mm	Squared timber girder	Squared timber girder	SKYDECK*	Formlining 21 mm	Squared timber girder	Squared timber girder	SKYDECK*	Formlining 21 mm	Squared timber girder	Squared timber girder	
	0	3.27	3.27	3.27	3.27	2.82	2.86	2.86	2.86	1.63	2.60	2.60	2.60	0.97	2.21	1.69	1.90
0.20	1.19	2.75	2.05	1.88	0.71	1.64	1.24	1.32	0.45	1.02	0.79	0.99	-	0.69	0.54	0.76	
0.25	1.07	2.46	1.84	1.63	0.61	1.39	1.06	1.16	0.39	0.88	0.68	0.87	-	0.60	0.47	0.67	
0.30	0.93	2.15	1.61	1.43	0.54	1.23	0.94	1.03	-	0.77	0.60	0.78	-	0.53	0.41	0.60	
0.35	0.82	1.89	1.41	1.28	0.47	1.08	0.83	0.92	-	0.69	0.53	0.69	-	0.47	-	0.54	
0.40	0.73	1.69	1.26	1.14	0.42	0.96	0.73	0.83	-	0.62	0.48	0.63	-	0.42	-	0.49	

Substructure		Height of side formwork h [m]											
		0.40				0.50				0.60			
		nailed onto		clamped to		nailed onto		clamped to		nailed onto		clamped to	
Slab thickness d [m]	SKYDECK*	Formlining 21 mm	Squared timber girder	Squared timber girder	SKYDECK*	Formlining 21 mm	Squared timber girder	Squared timber girder	SKYDECK*	Formlining 21 mm	Squared timber girder	Squared timber girder	
	0	0.62	1.41	1.09	1.40	-	0.68	0.53	0.83	-	-	-	0.54
0.20	-	0.49	-	0.60	-	-	-	0.40	-	-	-	-	
0.25	-	0.43	-	0.53	-	-	-	-	-	-	-	-	
0.30	-	-	-	0.48	-	-	-	-	-	-	-	-	
0.35	-	-	-	0.44	-	-	-	-	-	-	-	-	
0.40	-	-	-	0.40	-	-	-	-	-	-	-	-	

- The nailing process is carried out with 8 nails with \varnothing 3.1 mm (6 at the front, 2 at the back)

* Using the Guardrail Post AW on SKYDECK panels is not permitted.

Separate structural calculations must be provided to show that the sub-structure can carry all resulting loads. The equivalent load ($V/100$) acting horizontally and the pressures arising on one side (e.g. the edge beam) are to be accommodated by suitable means provided by the contractor.

1. Slab formwork



2. Slab with edge beam

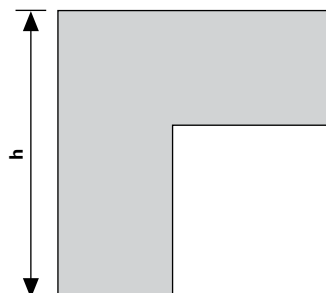

3. Slab with T-beam

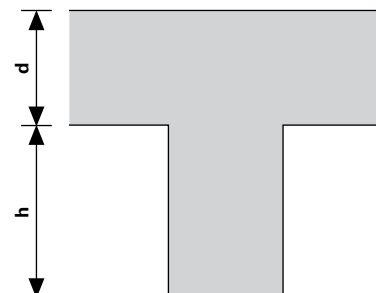

Beam Plastic Stopend Angle

Plastic Stopend Angle

Permissible influence width [m] for Plastic Stopend Angle depending on the slab thickness, beam height and fixing method

		Stopend for slab formwork (1.) Edge beam (2.)				T-beam (3.)											
						x_2 [m]											
		0.00				0.20				0.25				0.30			
Substructure	x_1 [m]	nailed onto				nailed onto				nailed onto				nailed onto			
		Fin-Ply [mm]			Squared timber	Fin-Ply [mm]			Squared timber	Fin-Ply [mm]			Squared timber	Fin-Ply [mm]			Squared timber
		9	15	21	Girders	9	15	21	Girders	9	15	21	Girders	9	15	21	Girders
	0.00					3.27	3.27	3.27	3.27	1.67	2.73	2.86	2.86	0.96	1.56	2.44	1.66
	0.20	2.33	3.27	3.27	3.27	0.73	1.20	1.66	1.26	0.43	0.70	0.97	0.75	0.28	0.45	0.67	0.49
	0.25	1.21	1.97	2.74	2.09	0.62	1.02	1.41	1.08	0.38	0.61	0.85	0.66	0.24	0.39	0.58	0.42
	0.30	0.72	1.17	1.62	1.25	0.54	0.89	1.24	0.94	0.32	0.53	0.73	0.57	-	0.35	0.51	0.37
	0.33	0.54	0.88	1.21	0.94	0.50	0.93	1.15	0.87	0.30	0.49	0.68	0.52	-	0.32	0.47	0.35
	0.35	0.45	0.73	1.01	0.78	0.48	0.79	1.09	0.83	0.29	0.47	0.65	0.50	-	0.31	0.45	0.33
	0.40	0.30	0.48	0.67	0.52	0.43	0.70	0.98	0.74	0.26	0.42	0.59	0.45	-	0.28	0.41	0.30

		T-beam (3.)											
		x_2 [m]											
		0.35				0.40				0.50			
Substructure	x_1 [m]	nailed onto				nailed onto				nailed onto			
		Fin-Ply [mm]			Squared timber	Fin-Ply [mm]			Squared timber	Fin-Ply [mm]			Squared timber
		9	15	21	Girders	9	15	21	Girders	9	15	21	Girders
	0.00	0.59	0.96	1.33	1.02	0.39	0.63	0.88	0.68	-	0.32	0.44	0.34
	0.20	-	0.31	0.43	0.33	-	-	0.31	0.24	-	-	-	-
	0.25	-	0.27	0.38	0.29	-	-	0.28	-	-	-	-	-
	0.30	-	0.24	0.34	0.26	-	-	0.24	-	-	-	-	-
	0.33	-	-	0.31	0.24	-	-	-	-	-	-	-	-
	0.35	-	-	0.30	-	-	-	-	-	-	-	-	-
	0.40	-	-	0.27	-	-	-	-	-	-	-	-	-

- The nailing process is carried out with 8 nails with \varnothing 3.1 mm (6 at the front, 2 at the back)

Separate structural calculations must be provided to show that the sub-structure can carry all resulting loads. The equivalent load ($V/100$) acting horizontally and the pressures arising on one side (e.g. the edge beam) are to be accommodated by suitable means provided by the contractor.

The Plastic Stopend Angle must not be used as a bracket in order to carry loads, for example, a cantilevered slab or a work platform.

1. Slab formwork



2. Slab with edge beam

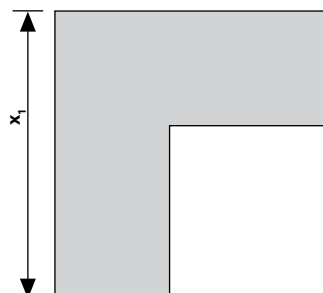

3. Slab with T-beam

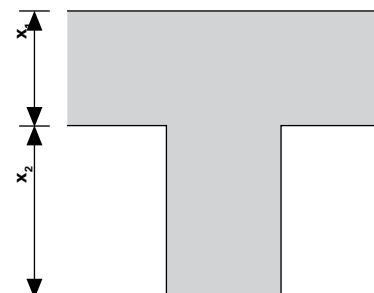

Slab Stopend Bar 105

Permissible spacings [m] depending on the slab thickness

Slab thickness d [m]	0.20	0.30	0.40	0.50	Hole
with lateral protection (guardrail boards or Lateral Protection Barrier PMB)	1.20	1.12	0.80	0.66	1
	1.20	1.12	0.93	0.76	2
	1.30	1.24	1.14	0.99	3
	1.43	1.37	1.34	-	4
	1.58	1.53	-	-	5
	1.77	-	-	-	6
without lateral protection	1.75	1.15	0.80	0.66	1
	2.22	1.56	1.12	0.89	2
	2.90	2.07	1.45	1.21	3
	3.00	1.67	2.00	-	4
	3.00	3.00	-	-	5
	3.00	-	-	-	6

Use in conjunction with HSGP-2 and boards 15/3.

The connection to the structure is made, for example, with stopend sleeve 15*.

The max. tie tensile force is 6.3 kN.

* For applications with edge distances $a < 15$ cm, separate verification of the anchoring is necessary.

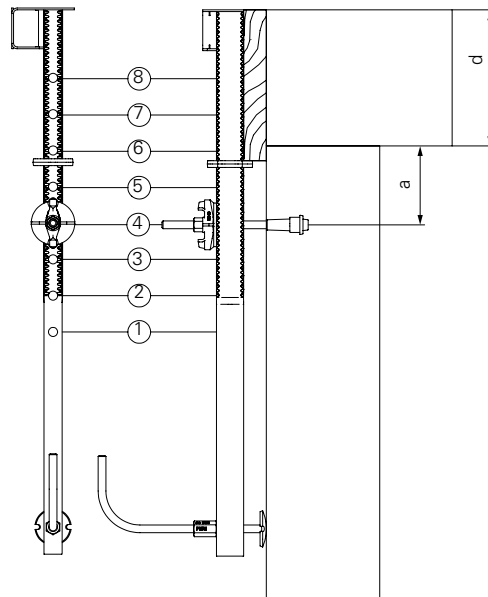

MULTIFLEX Girder Slab Formwork

Art no.	Weight [kg]		L [mm]
Girders GT 24			
075100	5.300	Girder GT 24 90	918
075120	7.100	Girder GT 24 120	1214
075150	8.900	Girder GT 24 150	1510
075180	10.600	Girder GT 24 180	1806
075210	12.400	Girder GT 24 210	2102
075240	14.200	Girder GT 24 240	2398
075270	15.900	Girder GT 24 270	2694
075300	17.700	Girder GT 24 300	2990
075330	19.500	Girder GT 24 330	3286
075360	21.200	Girder GT 24 360	3582
075390	23.000	Girder GT 24 390	3878
075420	24.800	Girder GT 24 420	4174
075450	26.600	Girder GT 24 450	4470
075480	28.300	Girder GT 24 480	4766
075510	30.100	Girder GT 24 510	5062
075540	31.900	Girder GT 24 540	5358
075570	33.600	Girder GT 24 570	5654
075600	35.400	Girder GT 24 600	5950

Universal formwork girder made of wood.

Notes

Special lengths over 6 m are possible and can be provided on request.

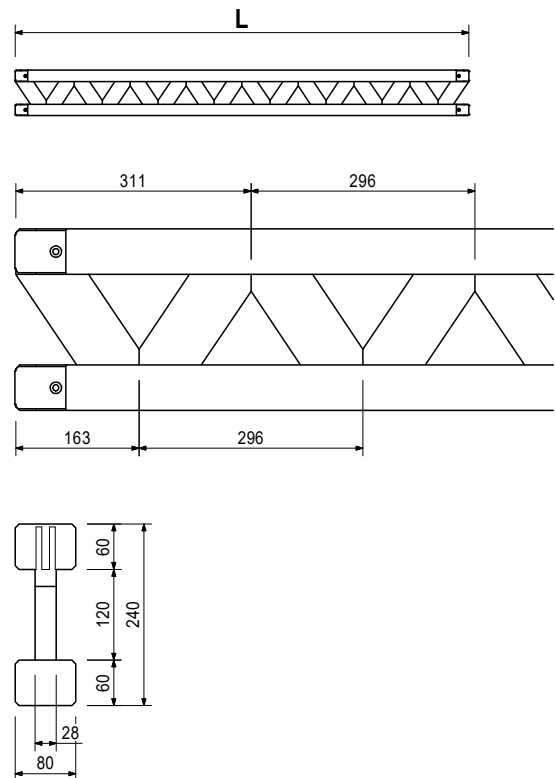
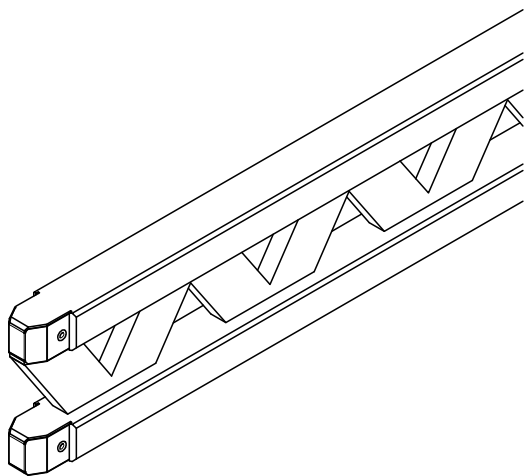

MULTIFLEX Girder Slab Formwork

Art no.	Weight [kg]		L [mm]
Girders VT 20K with Steel End Cap			
074990	8.230	Girder VT 20K 145	1447
074905	12.010	Girder VT 20K 215	2152
074910	13.630	Girder VT 20K 245	2452
074890	14.710	Girder VT 20K 265	2652
074920	16.060	Girder VT 20K 290	2902
074930	18.220	Girder VT 20K 330	3292
074940	19.840	Girder VT 20K 360	3592
074950	21.460	Girder VT 20K 390	3892
074960	24.700	Girder VT 20K 450	4492
074970	26.860	Girder VT 20K 490	4902
074980	32.260	Girder VT 20K 590	5902

Universal formwork girder made of wood.

Notes

The girder fulfils all requirements of DIN EN 13377 class P20 (Declaration of Conformity).

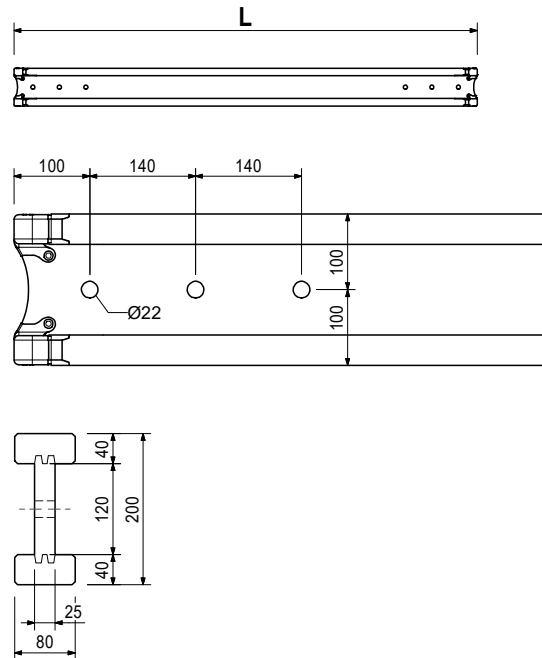
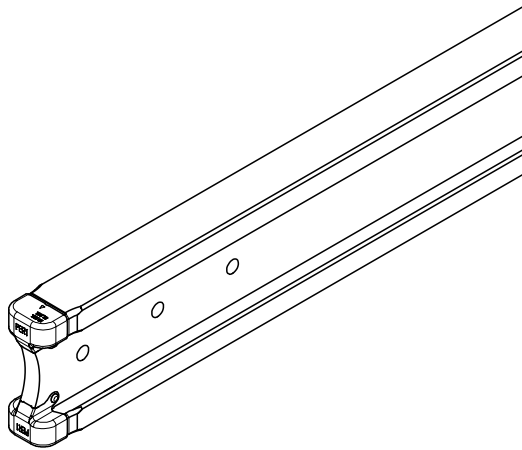

MULTIFLEX Girder Slab Formwork

Art no. Weight [kg]

Girders VT 20 Alpha

073650	7.830	Girder VT 20 Alpha 145
073651	11.610	Girder VT 20 Alpha 215
073652	13.230	Girder VT 20 Alpha 245
073653	14.310	Girder VT 20 Alpha 265
073654	15.660	Girder VT 20 Alpha 290
073655	17.820	Girder VT 20 Alpha 330
073656	19.440	Girder VT 20 Alpha 360
073657	21.060	Girder VT 20 Alpha 390
073658	24.300	Girder VT 20 Alpha 450
073659	26.460	Girder VT 20 Alpha 490
073660	31.860	Girder VT 20 Alpha 590

Universal formwork girder made of wood.

Notes

The girder fulfils all requirements of DIN EN 13377 class P20 (Declaration of Conformity).

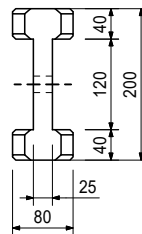
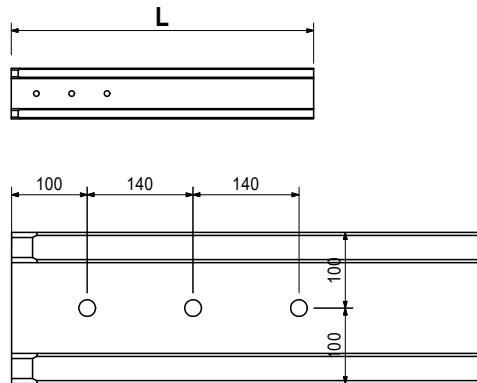
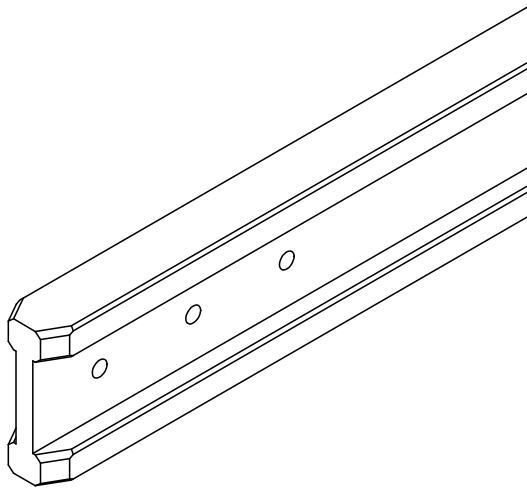

Art no. Weight [kg]

028870	5.430	Lowering Head 20/24 ga
--------	-------	-------------------------------

For tilt-resistant support of one or two GT 24 or VT 20 Girders. Lowering range 4 cm.

Notes

Required hole diameter of the prop end plate $\varnothing 40$ mm.

Girder overlap on both sides minimum 16.3 cm for GT 24 and 15 cm for VT 20.

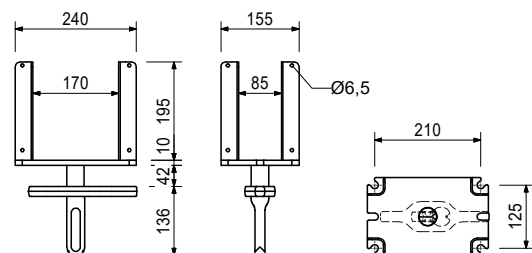
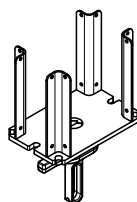

MULTIFLEX Girder Slab Formwork

Art no. Weight [kg]

Crossheads 20/24 ga

027890	3.080	Crosshead 20/24 ga
028680	3.190	Crosshead 20-24 S ga

With or without self-locking coupling.
For tilt-resistant support of one or two GT 24 or VT 20 Girders.

Notes

Required hole diameter of the prop end plate Ø40 mm.
Girder overlap on both sides minimum 16.3 cm for GT 24 and 15 cm for VT 20.

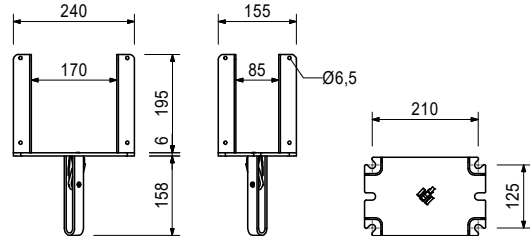
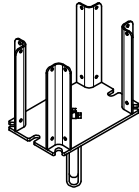

Accessory (not included)

027990	0.150	Pin Ø14x107 mm ga
018060	0.014	Cotter Pin 4/1 ga

Art no. Weight [kg]

Clawheads 24 ga

028880	1.540	Clawhead 24 ga
028890	1.650	Clawhead 24 S ga

With or without self-locking coupling. For positioning intermediate props on the GT 24 Girder without nailing.

Notes

Required hole diameter of the prop end plate Ø40 mm.

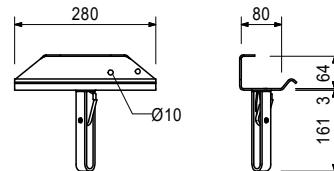
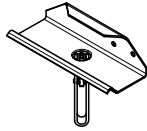

Accessory (not included)

027990	0.150	Pin Ø14x107 mm ga
018060	0.014	Cotter Pin 4/1 ga

MULTIFLEX Girder Slab Formwork

Art no. Weight [kg]

Clawheads 16/20 ga

028670	0.934	Clawhead 16-20 ga
028660	1.040	Clawhead 16-20 S ga

With or without self-locking coupling. For positioning intermediate props on the VT 20 Girder without nailing.

Notes

Required hole diameter of the prop end plate $\varnothing 40$ mm.

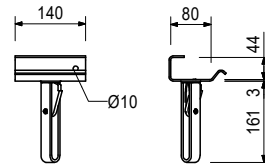
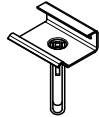

Accessory (not included)

027990	0.150	Pin $\varnothing 14 \times 107$ mm ga
018060	0.014	Cotter Pin 4/1 ga

Art no. Weight [kg]

028590	0.568	Tension Strap 16-25 ga
--------	-------	-------------------------------

For mounting 2 GT 24 or VT 20 Girders on the Cross Forkhead and Head Spindle TR 38 and on the Crosshead 20/24 or 20/24S.

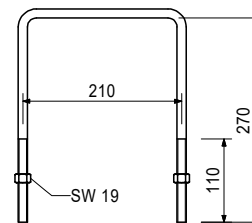
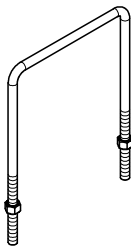

Art no. Weight [kg]

108213	2.590	Brace Connector MPB 24
--------	-------	-------------------------------

For connecting push-pull props or bracings to Aluminium Beam MPB 24.

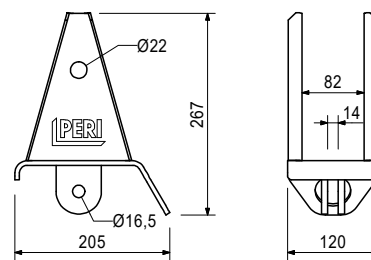
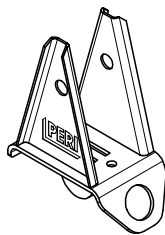

Accessory (not included)

104031	0.462	Fitting Pin $\varnothing 21 \times 120$ mm
018060	0.014	Cotter Pin 4/1 ga

MULTIFLEX Girder Slab Formwork

Art no.	Weight [kg]	
104031	0.462	Fitting Pin Ø21x120 mm

For different connections. High strength.

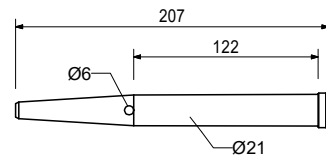
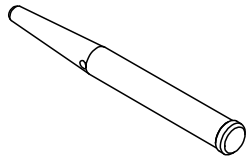

Accessory (not included)

018060	0.014	Cotter Pin 4/1 ga
--------	-------	--------------------------

Art no.	Weight [kg]	
027990	0.150	Pin Ø14x107 mm ga

For different connections.

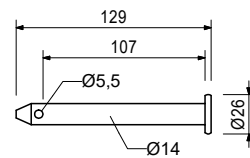
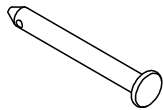

Accessory (not included)

018060	0.014	Cotter Pin 4/1 ga
--------	-------	--------------------------

Art no.	Weight [kg]	
018060	0.014	Cotter Pin 4/1 ga

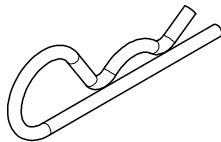

Art no.	Weight [kg]	
114359	9.170	Girder Head Pi. GT24/MPB/VT20d

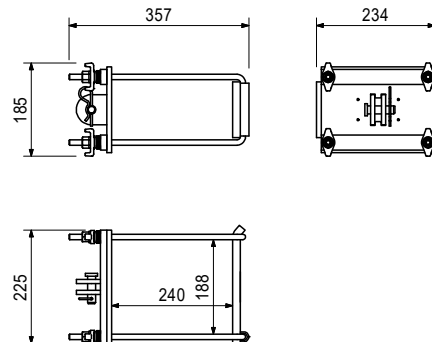
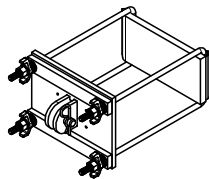

MULTIFLEX Girder Slab Formwork

Art no. Weight [kg]

028000 9.190 **Universal Tripod Ø57-120 mm**

Erection aid for slab props with Ø57–120 mm and 120x120 mm.

Can also be used in combination with MULTIPROP MP Slab Props and all slab props with Base MP 50.

Notes

Only use as erection aid!

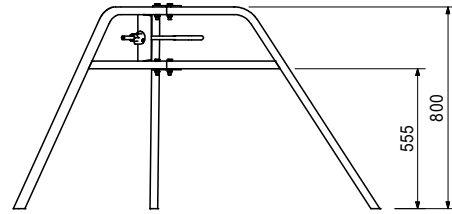
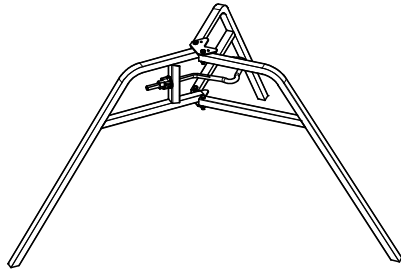

Art no. Weight [kg]

107152 5.810 **Tripod Ø44-64 mm**

Erection aid for PEP Ergo Slab Props with Ø44–64 mm.

Notes

Only use as erection aid!

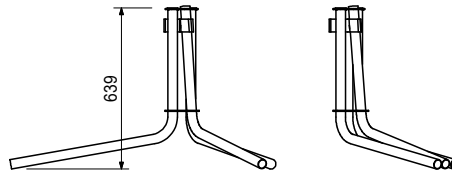
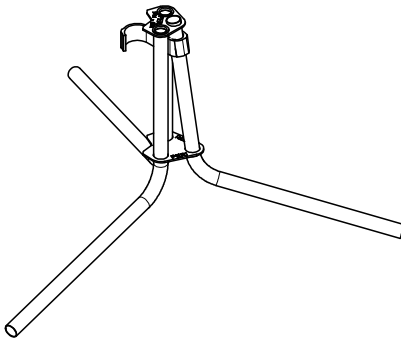

Art no. Weight [kg]

027940 1.840 **Brace Clamp Ø48-76 mm**

For assembly of 3x15 cm stiffening boards at slab props Ø48–76 mm.

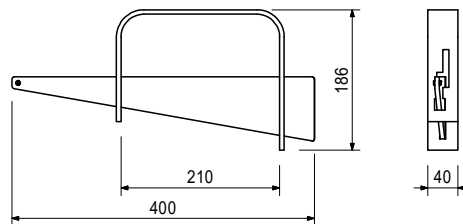
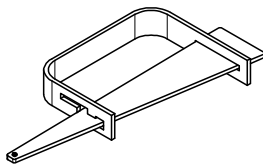

Art no. Weight [kg]

027790 2.460 **Brace Clamp Ø76-120 mm**

For assembly of 3x15 cm stiffening boards at slab props Ø76–89 mm and 100x100 mm to 120x120 mm.

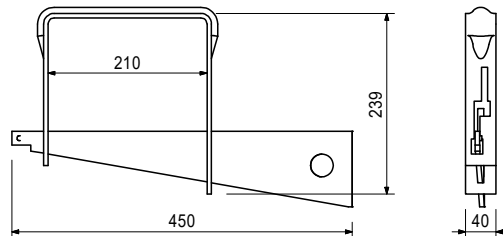
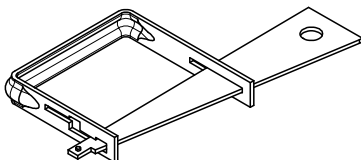

MULTIFLEX Girder Slab Formwork

Art no. Weight [kg]

027930	3.060	Assembly Bar 24 ga
--------	-------	---------------------------

For shuttering of MULTIFLEX with GT 24 Girders.

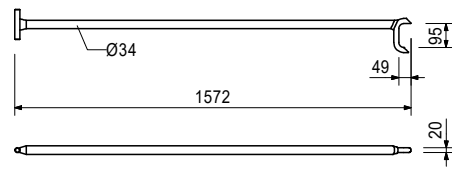
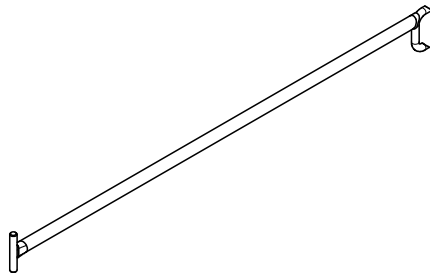

Art no. Weight [kg]

070740	2.980	Erection Bar GT 24/VT 20 ga
--------	-------	------------------------------------

For shuttering of MULTIFLEX with GT 24 or VT 20 Girders.

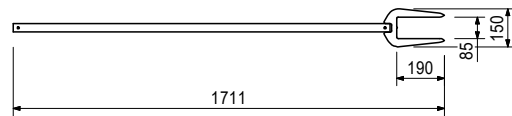
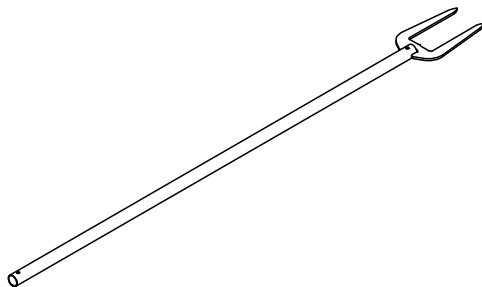

Art no. Weight [kg]

101290	5.670	Guardrail Holder GT 24/VT 20
--------	-------	-------------------------------------

For assembling a guardrail to GT 24 or VT 20 Girders.

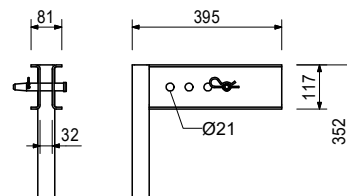
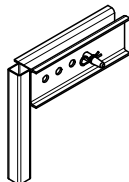

Accessory (not included)

116292	4.720	Guardrail Post-2 HSGP
061260	6.150	Guardrail Post SGP

Consists of

- 1 pc 105400 Pin Ø20x140 mm ga
- 1 pc 018060 Cotter Pin 4/1 ga

MULTIFLEX Girder Slab Formwork

Art no. Weight [kg]

116292	4.720	Guardrail Post-2 HSGP
--------	-------	------------------------------

As guardrail for different systems.

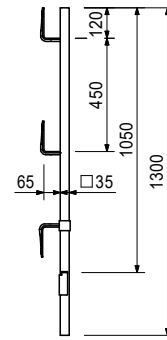

Art no. Weight [kg]

061260	6.150	Guardrail Post SGP
--------	-------	---------------------------

As guardrail for different systems.

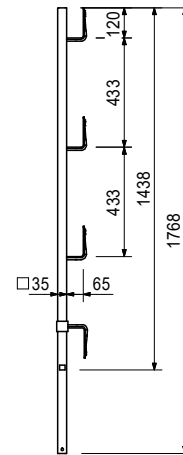

Art no. Weight [kg]

L [mm]

		Side Mesh Barriers PMB	
126381	7.140	Side Mesh Barrier PMB 90	900
126376	9.260	Side Mesh Barrier PMB 120	1200
117327	10.500	Side Mesh Barrier PMB 130	1300
126371	17.700	Side Mesh Barrier PMB 240	2400
117326	19.700	Side Mesh Barrier PMB 260	2600

Notes

Maximum distance with side mesh barrier: PMB 260 max. 2.4 m.

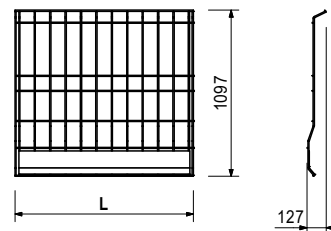
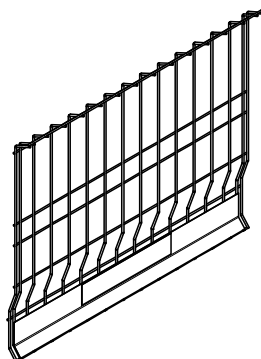

MULTIFLEX Girder Slab Formwork

Art no.	Weight [kg]		L [mm]
Side Mesh Barriers PMB S			
138087	5.940	Side Mesh Barrier PMB S 90	900
138086	7.920	Side Mesh Barrier PMB S 120	1200
138085	14.560	Side Mesh Barrier PMB S 240	2400
138084	16.060	Side Mesh Barrier PMB S 260	2600

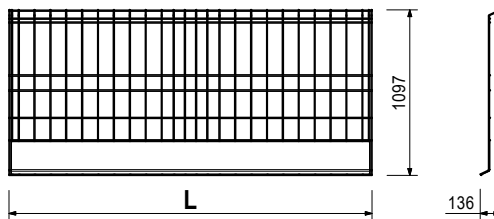
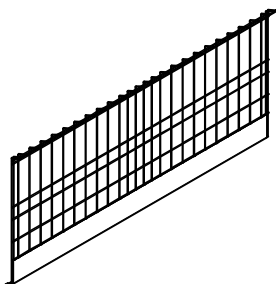

Art no.	Weight [kg]	
018290	0.098	Framing Clip ga

For various wood connections.

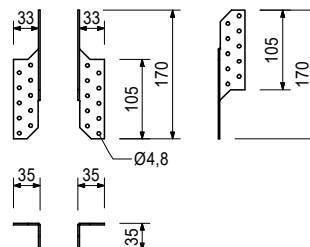
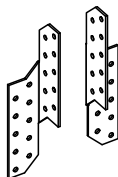

Accessory (not included)

018280	1.000	Double Head Nail 65 mm
--------	-------	-------------------------------

Art no.	Weight [kg]	
018280	1.000	Double Head Nail 65 mm

Notes

Delivery unit: carton with 1000 pieces.

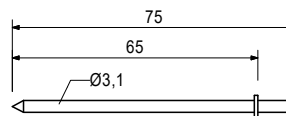
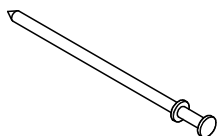

MULTIFLEX Girder Slab Formwork

Art no. Weight [kg]

130444 78.000 **Stripping Cart-2 Alu**

Mobile working scaffold. Height-adjustable in 25 cm increments. Platform height: max. 2 m.

Notes

Follow Instruction for Use!
Permissible load 100kg/m².

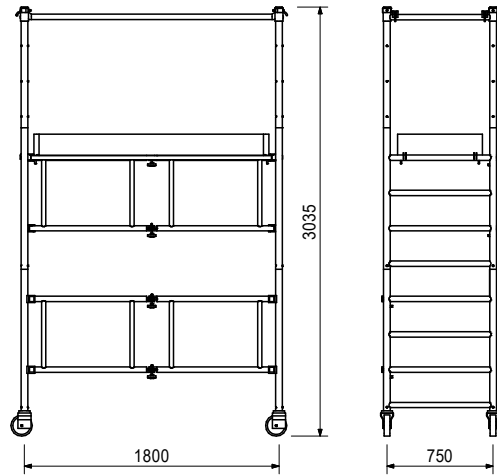
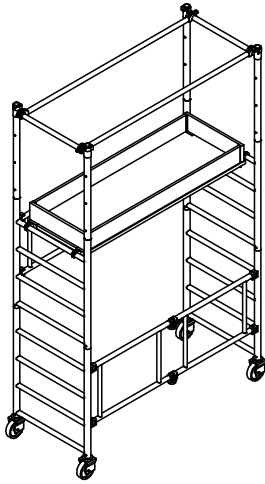

MULTIFLEX Girder Slab Formwork

Art no.	Weight [kg]	
102031	363.000	Stripping Cart ASW 465

Mobile working scaffold. Height-adjustable in 30-cm-increments. Platform height max. 4.65 m.

Packed in:
 Ring Pallet USP 104 Item no. 100678, with Lashing Strap 25x575 Item no. 100707 (x 1) and
 Scaffold Tube Steel L=100 Item no. 100706 (x 6).

Notes

Follow Instructions for Use!
 Permissible load 100kg/m².

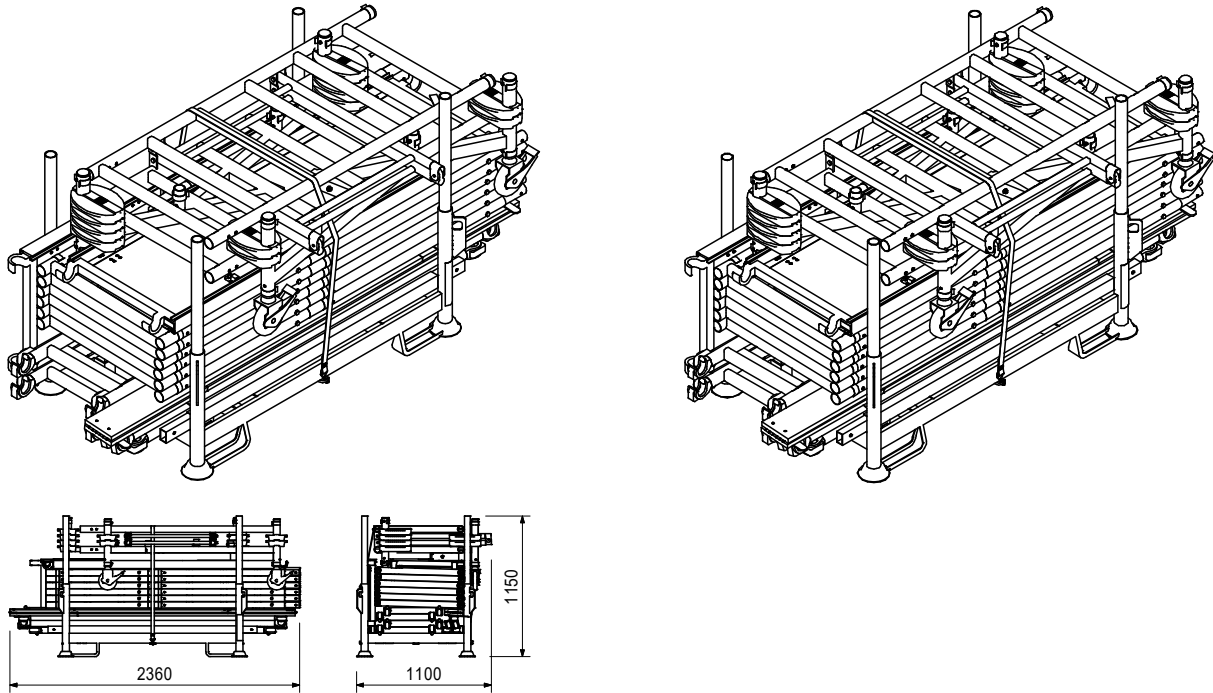

Consists of

- 1 pc 102025 Folding Base Unit ASW 160/190
- 6 pc 102035 Vertical Frame ASW 70/90
- 6 pc 102034 Vertical Frame ASW 70/120
- 2 pc 102026 Entry Platform ASW 190
- 1 pc 102030 Toe-Board Set ASW 70/190
- 4 pc 102027 Double Handrail ASW 190
- 3 pc 102028 Diagonal Brace ASW 210
- 2 pc 102029 Horizontal Brace ASW 190
- 12 pc 102807 Ballast ASW 10kg
- 2 pc 103040 Side Section ASW comp
- 1 pc 102587 Centre Piece ASW coat

Art no.	Weight [kg]	
136713	8.630	Striking Hammer SXP SH

For shuttering up to a height of 5,30 m.

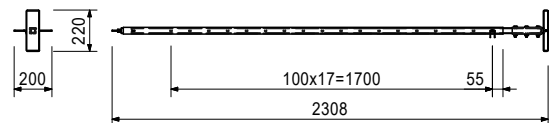
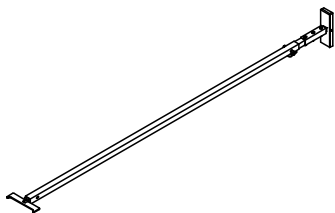

MULTIFLEX Girder Slab Formwork

Art no. Weight [kg]

116614 0.537 **Flexclip GT 24/GT 24**

For connecting girders GT 24/GT 24.

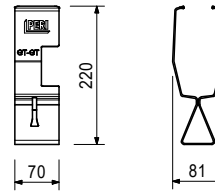

Art no. Weight [kg]

116605 0.493 **Flexclip GT 24/VT 20**

For connecting girders GT 24/VT 20.

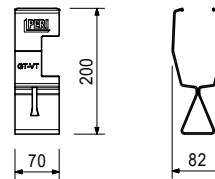

Art no. Weight [kg]

116596 0.467 **Flexclip VT 20/VT 20**

For connecting girders VT 20/VT 20.

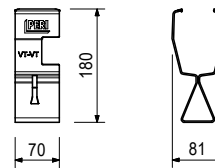

Art no. Weight [kg]

117575 0.202 **Fixing Tool Flexclip coat**

For assembling Flexclips onto the formwork girders.

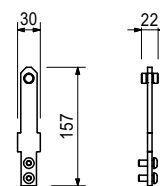

Consists of

2 pc 117097 Screw ISO7380-M8x020-10.9-vz

MULTIFLEX Girder Slab Formwork

Art no. Weight [kg]

117574 5.940 **Distance Device MULTIFLEX Plus**

For placing, positioning on given distance and aligning the formwork girders at the MULTIFLEX System, as well as assembling the Flexclips.

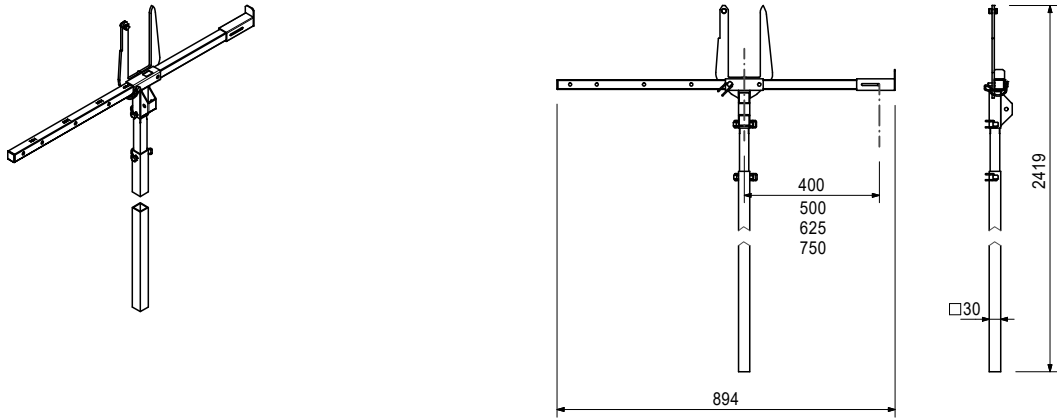

Art no. Weight [kg]

110103 1.200 **Telesc. Tube coat**

For assembling the Flexclip in combination with Fixing Tool Flexclip, galv.



Accessory (not included)

117575 0.202 **Fixing Tool Flexclip coat**

MULTIFLEX Girder Slab Formwork

Art no. Weight [kg]

065056 11.300 **UZ Beam Bracket 40**

For forming beams up to 80 cm high. With captive Hook Tie and Wingnut Counterplate.

Notes

Permissible load: see PERI Design Tables.

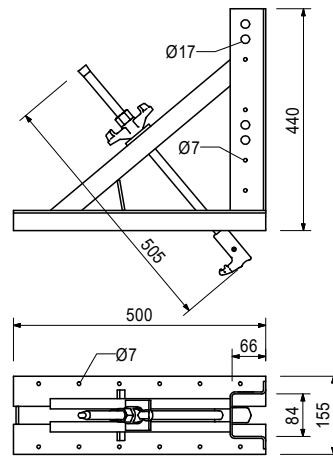
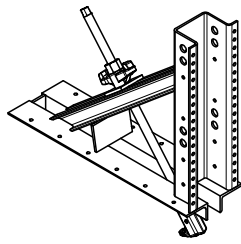

Art no. Weight [kg]

065057 7.060 **UZ Beam Adjustment Bar 80**

For use with UZ Beam Bracket 40. For beam width max. 40 cm. Beam width more than 40 cm 2 or more of the UZ Beam Width Adjustment Bars 80 to be connected.

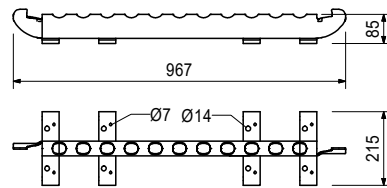
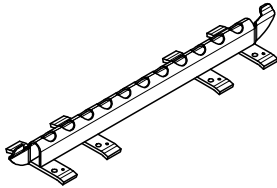

Art no. Weight [kg]

065065 10.000 **UZ Beam Adjustment Bar 129**

For use with UZ Beam Bracket 40. For beam width max. 90 cm. Beam width more than 90 cm 2 or more of the UZ Beam Width Adjustment Bars to be connected.

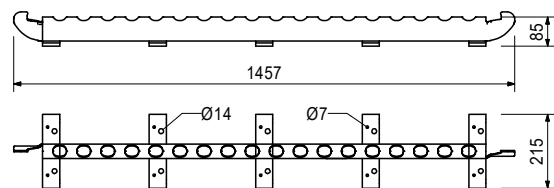
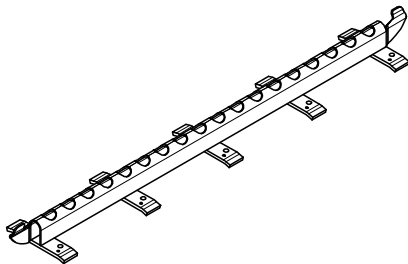

Art no. Weight [kg]

365072 3.270 **AW Clamp 8-10**

For clamping the AW Slab Stopend Angle to girders or timbers with 8–10 cm thickness. With captive Triple Wingnut.

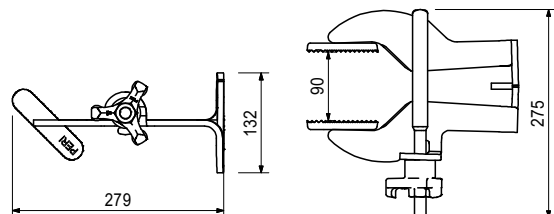
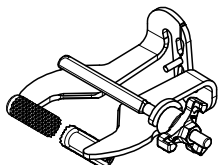

MULTIFLEX Girder Slab Formwork

Art no.	Weight [kg]	
365070	1.670	AW Slab Stopend Angle

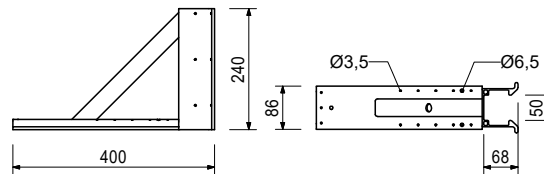
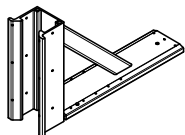

Art no.	Weight [kg]	
126299	0.466	Slab Stopend Angle Plastic

Notes

See data sheet!

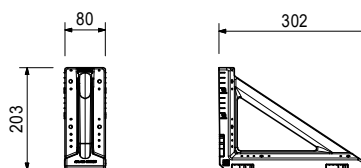
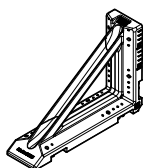

Art no.	Weight [kg]	
065063	6.630	Slab Stopend Bar 105

For forming with vertical slab stopend formwork for up to 50 cm slab thicknesses.

Notes

Permissible load: see PERI Design Tables.

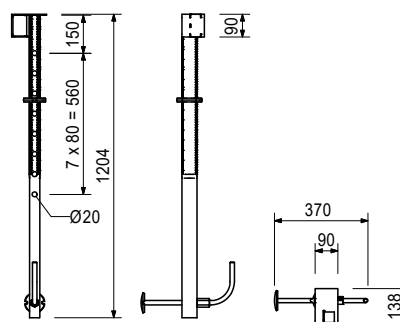
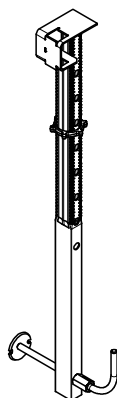

Accessory (not included)

116292	4.720	Guardrail Post-2 HSGP
--------	-------	------------------------------

MULTIFLEX Girder Slab Formwork

Art no.	Weight [kg]	
136615	642.000	Flexbase SKY ANCHOR

Notes

Mobile anchor device according to DIN EN 795 E in combination with accessories below.
Follow Instructions for Use!

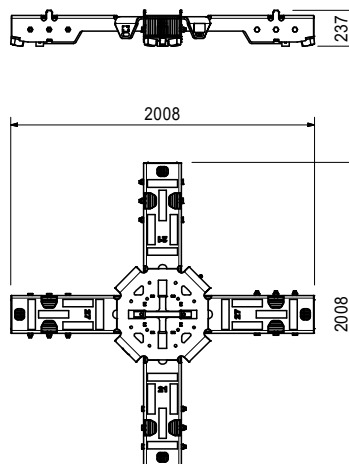
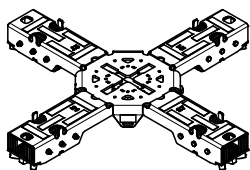

Accessory (not included)

131032	17.000	SKY ANCHOR 21
133904	17.000	SKY ANCHOR 27

Consists of

- 1 pc 129441 RFID LA-TAG D22 Assembly Set
- 12 pc 136612 Wheel Buffer RP-HR-40x45x80 mm
- 4 pc 136613 Rubber Metal Stop 35
- 24 pc 136614 Screw ISO4762-M06x016-8.8-ga
- 8 pc 710416 Screw ISO4762-M08x016-8.8-ga

Art no.	Weight [kg]	
131032	17.000	SKY ANCHOR 21

Notes

Attaching device according to DIN EN 795 B.
Follow Instructions for Use!

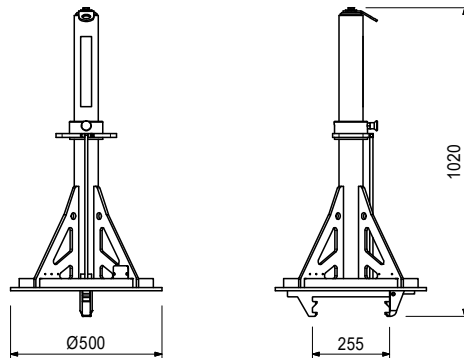
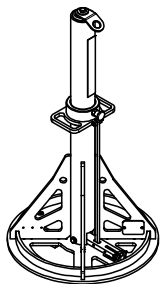

MULTIFLEX Girder Slab Formwork

Art no.	Weight [kg]	
133904	17.000	SKY ANCHOR 27

Notes

Attachment equipment according to DIN EN 795 B.
Follow Instructions for Use!

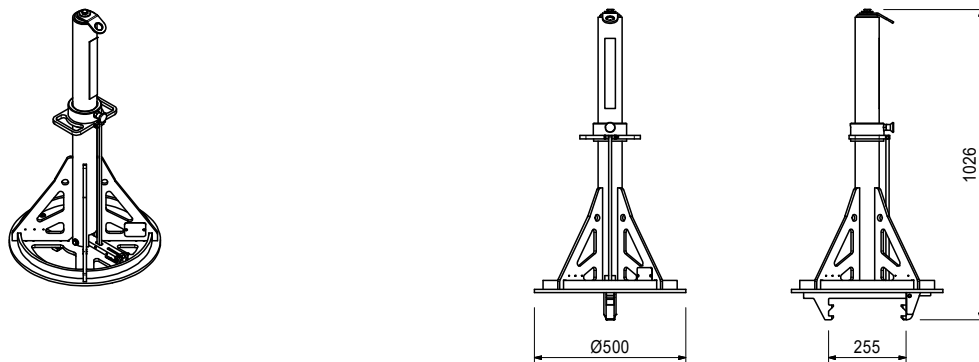

Art no.	Weight [kg]	
131680	0.193	Carabiner oval 65x111 mm



Art no.	Weight [kg]	
131033	1.500	Retract. Fall Arrester EN360

Notes

Extension length 5.5 m.
Follow Instructions Manual!



MULTIFLEX Girder Slab Formwork

Art no.	Weight [kg]		B [mm]	L [mm]
138072	2.300	Retract.Fall Arrester 9 m EN360	168	480

Notes

Extension length 9.0 m.
Follow Instructions for Use!

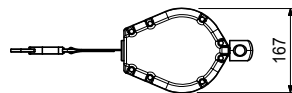
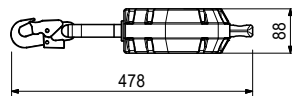
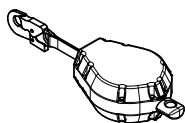

Art no.	Weight [kg]			
131034	0.950	Fullbody Harness		

Notes

Universal size!
According to DIN EN 361!
Follow Instruction Manuel!

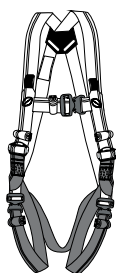

Accessory (not included)

131033	1.500	Retract. Fall Arrester EN360
131680	0.193	Carabiner oval 65x111 mm
138072	2.300	Retract.Fall Arrester 9 m EN360

Art no.	Weight [kg]		L [mm]
Pallets RP-2 ga			
103434	38.500	Pallet RP 80x120/2 ga	1200
103429	45.300	Pallet RP 80x150/2 ga	1500

For stacking and transportation of formwork and scaffolding components.

Notes

Follow Instructions for Use!
Permissible load-bearing capacity 1.5t.

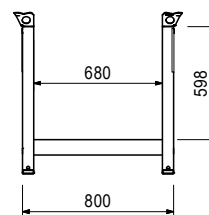
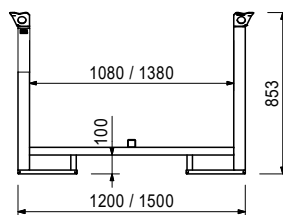
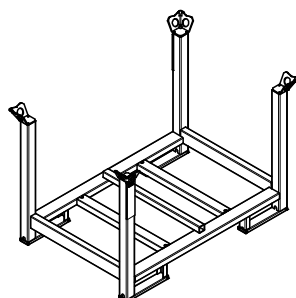

MULTIFLEX Girder Slab Formwork

Art no. Weight [kg]

061510 105.000 **Pallet Lifting Trolley 1800 mm**

For moving pallets and crate pallets.

Notes

Follow Instructions for Use!

Forklift arm length 1800 mm, forklift arm width 550 mm, stroke range 115 mm.

Permissible load-bearing capacity 2t.

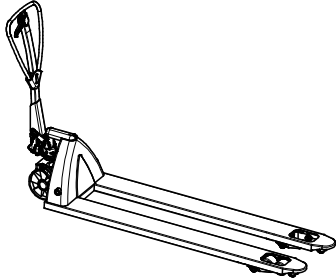

Art no. Weight [kg]

117321 31.000 **Lifting Gear Combi MAXIMO**

For transporting stacks of MAXIMO and TRIO Panels. For attaching Lifting Hook MAXIMO 1.5t and Stacking Device MAXIMO.

Notes

Follow Instructions for Use!

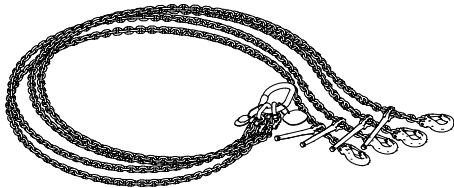

Art no. Weight [kg]

065073 1.370 **Anchor Chain 250/3.0 kN**

Notes

Permissible tension force 3.0 kN.

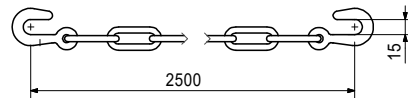
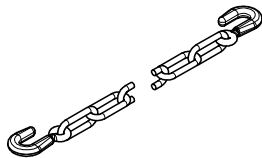

Art no. Weight [kg]

065074 0.450 **Turnbuckle M12/3.0 kN**

Notes

Permissible tension force 3.0 kN.

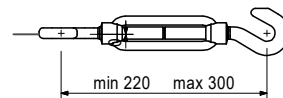
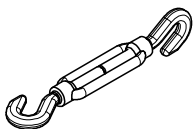

MULTIFLEX Girder Slab Formwork

Art no. Weight [kg]

028100 1.830 **Base Plate f. RS cpl**

For assembly of RS Push-Pull Props.

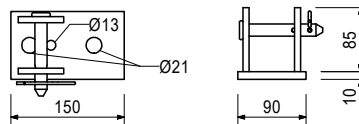

Consists of

1 pc 18050 Pin Ø16x65/86 mm ga

1 pc 18060 Cotter Pin 4/1 ga

**The optimal System
for every Project and
every Requirement**



Wall Formwork



Column Formwork



Slab Formwork



Climbing Systems



Bridge Formwork



Tunnel Formwork



Shoring Systems



Construction Scaffold



Facade Scaffold



Industrial Scaffold



Access



Protection Scaffold



Safety Systems



System-Independent Accessories



Services



PERI Norge AS
Forskaling Stillas Engineering
 Orhusveien 6
 3070 Sande i Vestfold
 Norge
 Tel. +47 32 20 49 40
 info@peri.no
 www.peri.no

